

Lunar Spaceport Architectures

Jeffrey Montes, Fellow, Open Lunar Foundation

Background / Motivation

Lunar spaceports (a.k.a.. launch/landing pads) will be a cornerstone of all but the most anemic lunar futures. Undoubtedly they are critical to any sustainable presence. The central problem spaceports address is the detrimental effects of ejecta, the global dispersal of lunar surface material (rocks, dust, etc.), caused by landing on and launching atop unprotected lunar ground. Because the Moon has no atmosphere, ejecta goes fast and far—potentially blanketing the globe at velocities that could damage infrastructure and undermine science, and reaching altitudes where satellites and orbital habitats live. This document is the output of a research fellowship taking a new look at lunar spaceports with Open Lunar Foundation, a non-

profit organization working on policy and partnerships that support a sustainable lunar settlement driven by open values. Consistent with this spirit, this is a working document for designers, engineers, and policy-makers interested in understanding this problem or applying the approach to other problems.

This isn't an engineering trade study, it isn't built on previously unpublished information, and it isn't intended as a set of ready-made designs to choose from. It is an architectural and conceptual exploration through geometry, mechanism, and concept of operation (CONOPS).

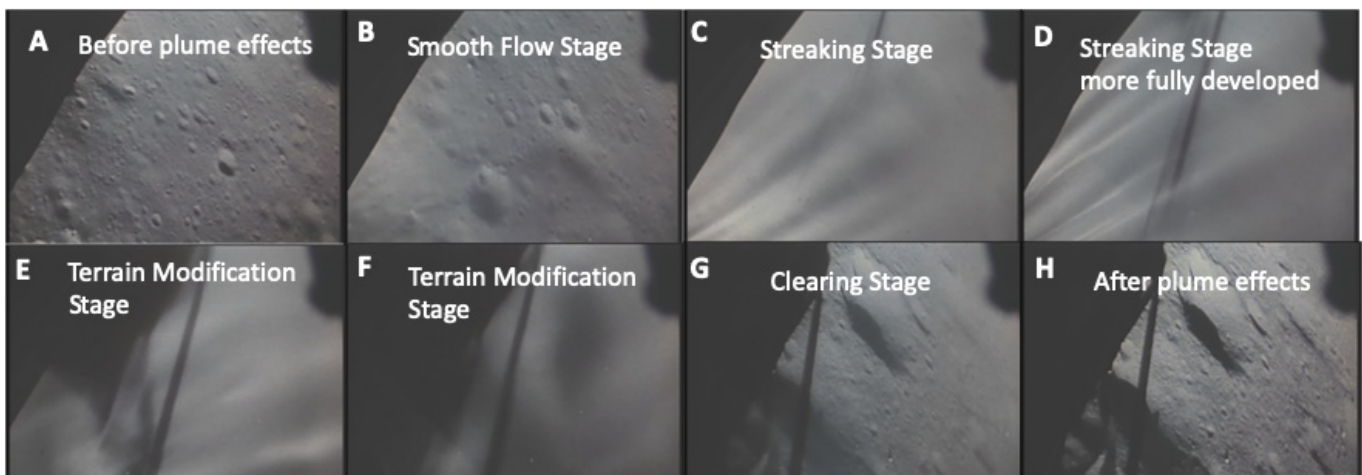

Fig. 1: Stages of rocket exhaust ejecta beneath an Apollo Lunar Module (Metzger et al., 2011).

Design Spaces

In *The Theoretical Minimum* Susskind and Hrabovsky define a concept called a state space:

"...the collection of all states occupied by a system is its ...state space. The state space is not ordinary space; it's a mathematical set whose elements label the possible states of the system. [p.3]

Similar to a state space, a design space is a solution domain defined by relatively detailed designs aimed at a common problem. The one-dimensional space between 0 and 1 is a continuum with an infinite number of values. For difficult and important problems at an early stage of development (such as lunar spaceports), fleshing out the extreme cases (the 0 and the 1) can more be effective at moving a community of designers towards discovery and invention than prescribing an inevitably wrong goldilocks.

This document maps a two-dimensional design space, which is by definition

bounded by four designs as four corners define a square room. Each design represents a corner of that space, an extreme value. None of the designs ought to be taken as the solution; instead they should aid designers in inventing unexpected hybrids.

Design spaces are useful for early stage problems. For a technology that does not yet exist a design space paints the scene and sets the ground for informed scrutiny. For problems without real-world solution precedents a design space can guide debates. It can be helpful for problems where a design framework has not been established. Designers flourish on constraints because they need a working model of a problem and its boundaries to understand which of those boundaries to push, which to bend or break, and which to respect. Finally, when open-sourcing a problem, a design space leaves room for future work to build upon.

Lunar Spaceport Architecture

A spaceport is a kind of armor for the lunar surface in that it protects the ground from the destructive force of rocket engine exhaust and prevents the ground from becoming a spray of high-velocity projectiles. In the absence of this surface armor, everything around the landing site would need to be armored and thus more massive, indiscriminately driving engineering margins. While many surface assets will need to be engineered against the likelihood of micrometeorite impact and other incidental damage, the risk of ejecta damage will result in unnecessarily large margins that levy substantial penalties felt at the system level. For this reason, investing in spaceports early is critical for asset longevity, risk reduction, coordination and policy, human safety, and programmatic durability.

There is increasing attention on in-Space resources as they relate to the hopeful cis-lunar economy and to lunar surface infrastructure. Among that infrastructure, spaceports stand out. For the "vibrant Earth-Moon future" NASA has outlined with the *Artemis* program, shuttling to and from the surface will be foundational and commonplace. A spaceport might itself be a product of an indigenous lunar material economy, or it might, like a spacecraft, be a product of Earth and imported to the Moon. The structural, material and production differences between in situ and imported artifacts has a fundamental effect on their design and is the first of two axes of the design space.

In *Pad for Humanity: Lunar Spaceports as Critical Shared Infrastructure*, Montes et al.

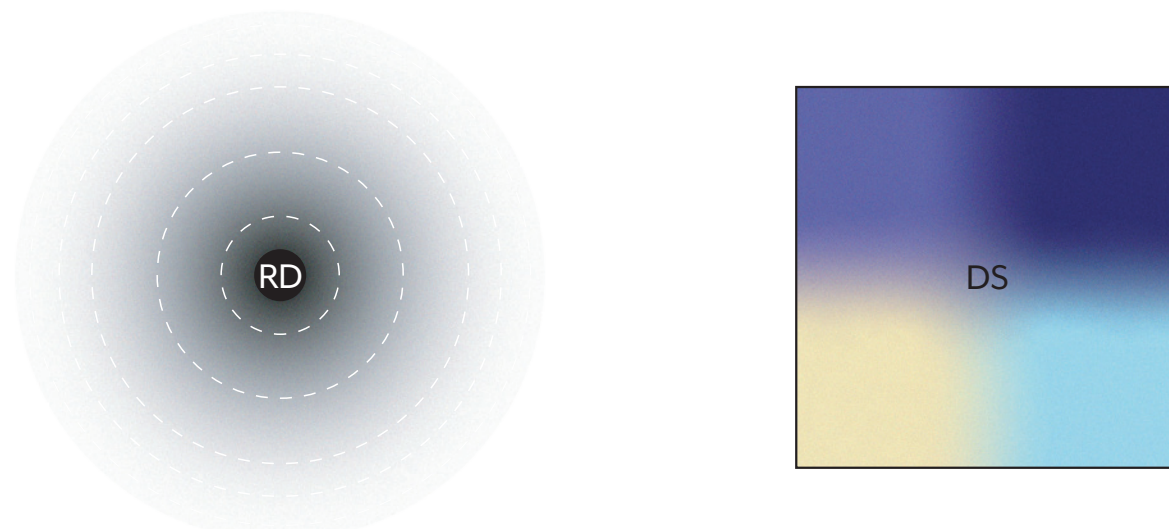
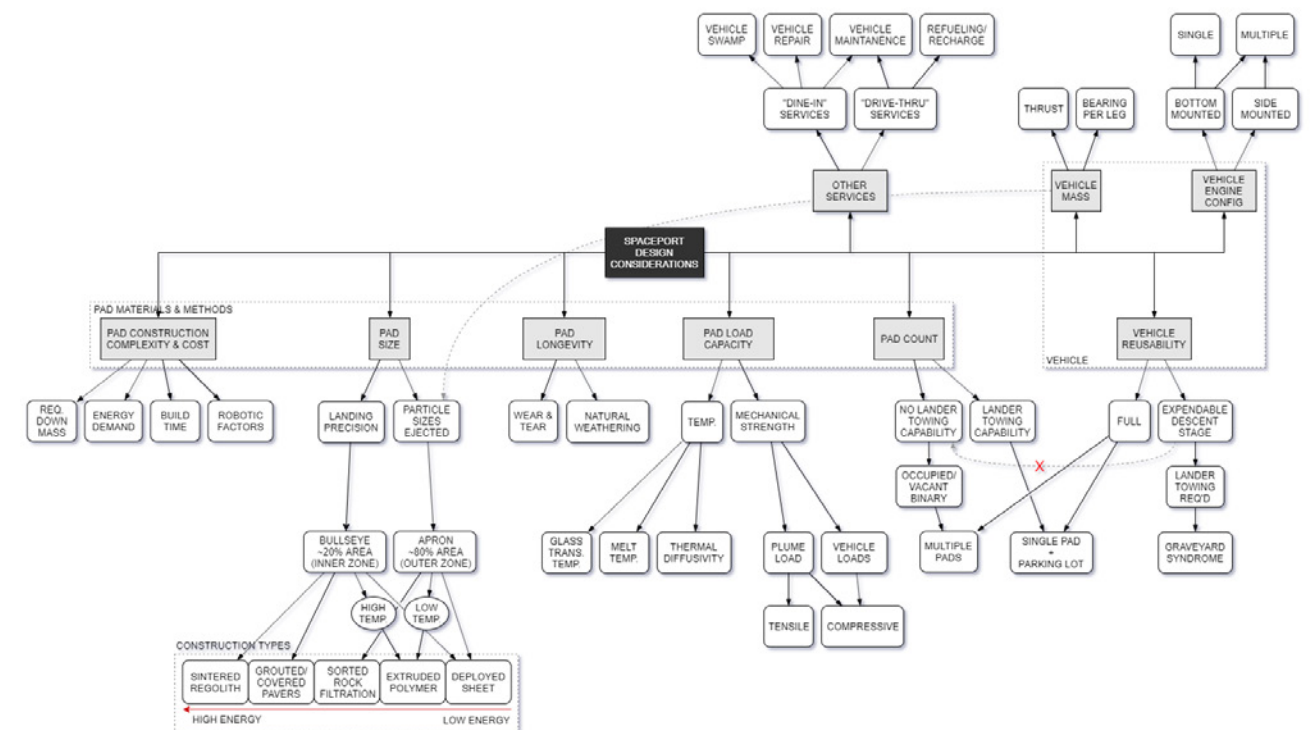

Fig. 2: One-dimensional reference design (left); multi-dimensional design space (right)

Fig. 3: A map of spaceport design considerations. (Montes, et al., 2020).

defined spaceports as “a facility providing a site for vertical rocket transport to and from the lunar surface and supporting services including but not limited to refueling, recharging and maintenance.” The most basic spaceport imaginable is nothing more than ground armor - a flat pad engineered to resist lunar weathering and the thermal and mechanical loads of

visiting vehicles. Beyond that, spaceports can get more sophisticated; offering “drive thru” services to visiting vehicles such as refueling, recharging and maintenance. The impact feature-richness has on design and complexity make it the second design space axis.

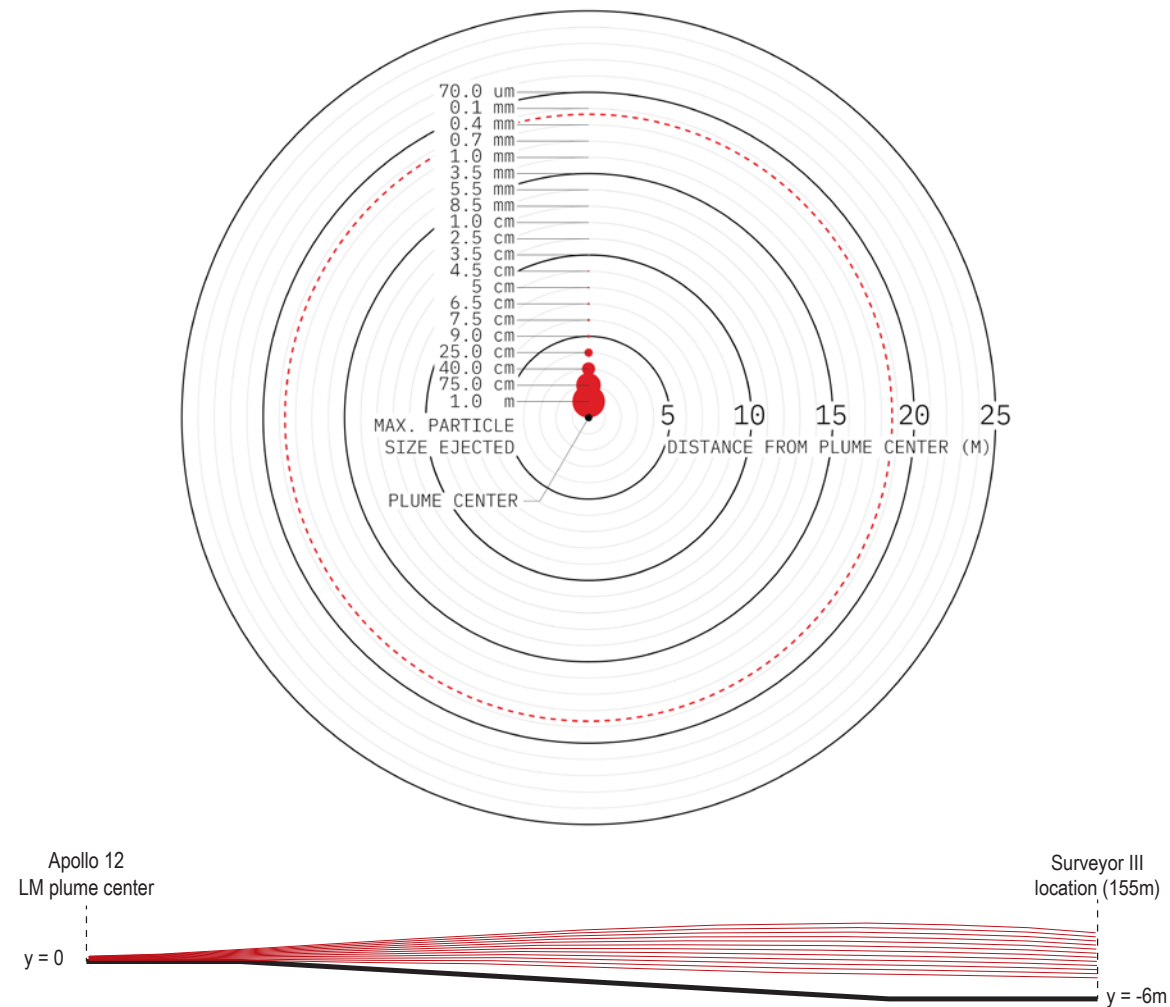

Figure 3: A polar graph showing the size of particles blown (red dots, to scale) as a function of distance from the center of the exhaust plume (concentric rings) for a 40 t lander. The dashed line marks the threshold beyond which 126 micron particles cease to be blown. Figure by author after Van Susante & Metzger (2014).

Figure 4: The main “sheet” of ejecta (dust, sand, gravel and rocks) traveling upward at an approximately 1-3 degree slope and away from the Apollo 12 LM. Surveyor 3 was located beneath the main sheet so was only damaged by a fraction of the impacts that would have occurred if directly exposed. Figure following Tosh, et al., (2011).

The Four Designs

Four designs, defining a two-dimensional design space, are explored. The differences between the four designs are essentialized in the design space plot diagram. All emerge from the same need to mitigate ejecta but exist under distinct circumstances. As such, all of the designs are structures that perform this basic function. Just as an aircraft

carrier and a commercial airport differ in performance and circumstance but share the same essential function, the following designs do not perform equally but rather are intended to embody the essence of their boundary-defining point in a shared design space.

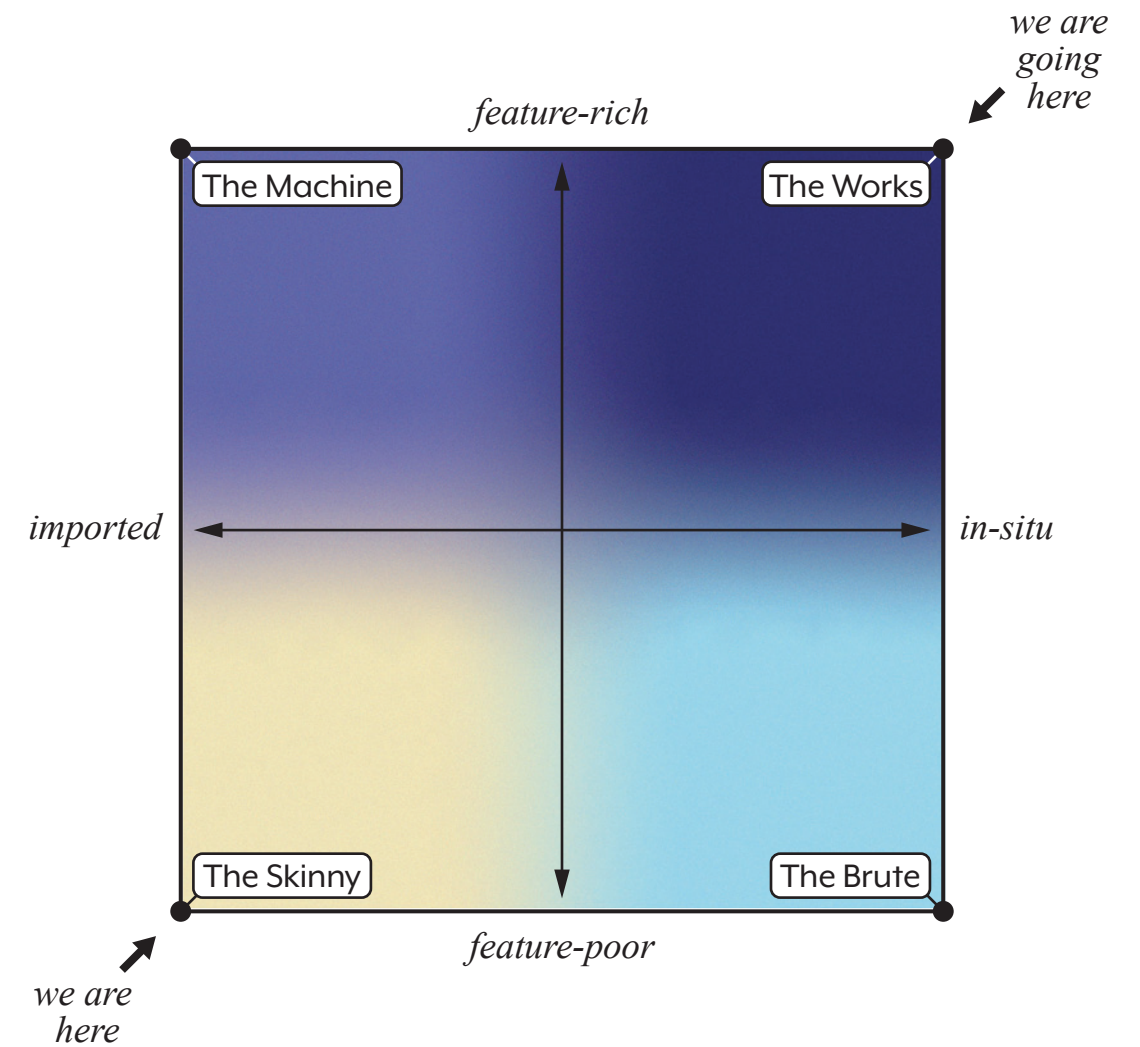

THE SKINNY

FEATURE-POOR, IMPORTED LUNAR SPACEPORT

- | | | |
|--------------------------|--------------------------------|--------------------------|
| <i>a. textile apron</i> | <i>f. payload fairing</i> | <i>p. rigid panels</i> |
| <i>b. pad base</i> | <i>h. hoist rig</i> | <i>s. stowed payload</i> |
| <i>d. pad deck</i> | <i>l. lander</i> | <i>t. expanding tube</i> |
| <i>e. engine exhaust</i> | <i>n. rocket engine nozzle</i> | <i>z. pad zones</i> |

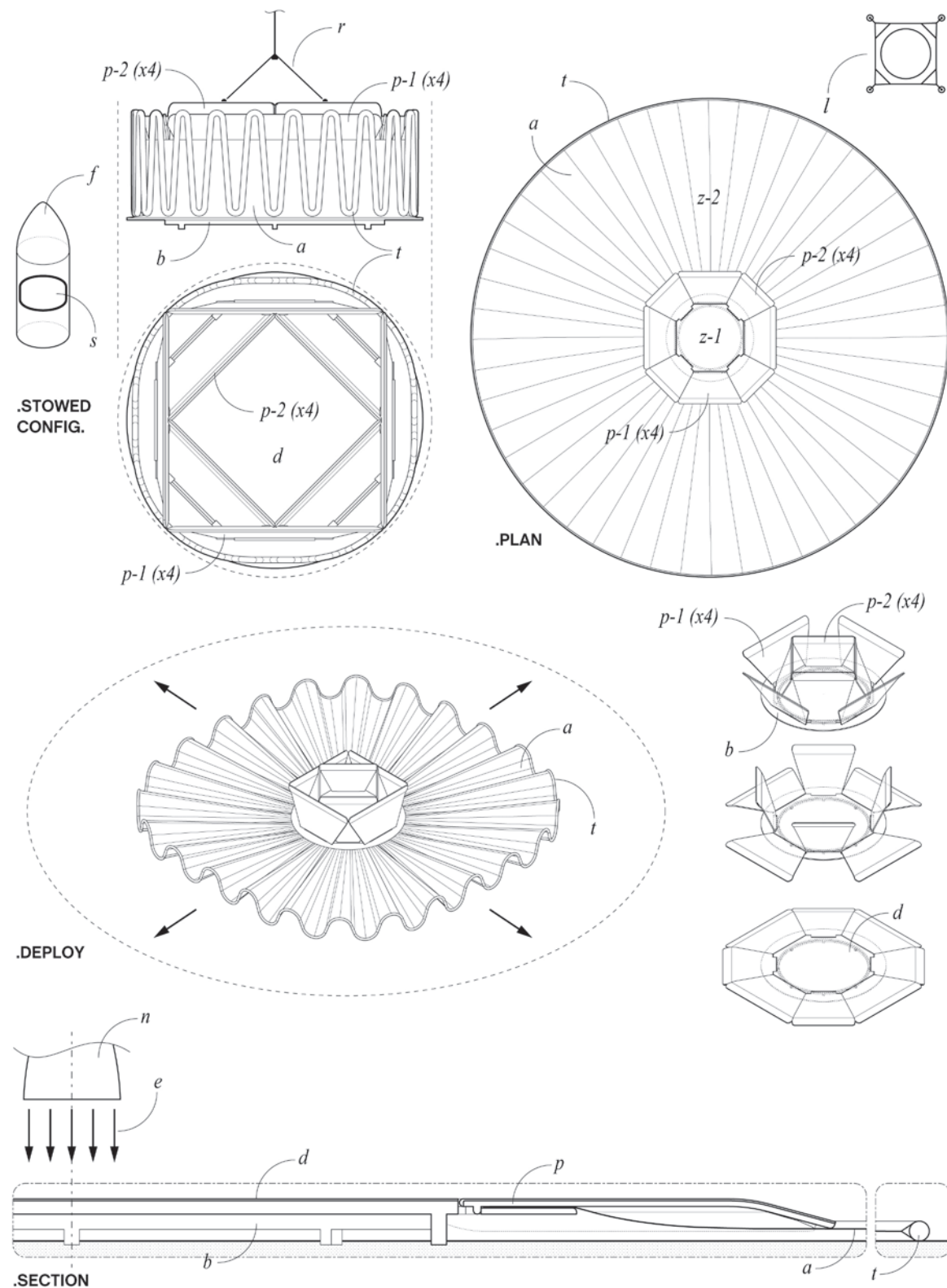

by Jeffrey Montes with Open Lunar Foundation

The Skinny is a lightweight spaceport imported from Earth and deployed on the lunar surface. It performs only the essential function of a spaceport.

Architecture

The Skinny has two zones - a central "bullseye" and an outer "apron". The bullseye, which sits directly under the lander engines, must withstand the thermal and mechanical loads of the rocket engine exhaust. This zone is made of metal panels that unfold from a stowed configuration into an octagonal platform. The apron borders the bullseye and extends out. It is made of a heat-resistant textile deployed into shape by an expanding tube filled with gas or an expanding foam. While the apron will experience lesser loads than the bullseye, the fringes of the engine exhaust retain enough energy to create ejecta of smaller particle sizes (Fig. 3)

CONOPS

Delivered to the lunar surface as lander payload, it is hoisted from the lander using a crane, which places it on prepared (leveled and flattened) ground. The deployment sequence begins with the expansion of the outer tube, which tensions the apron. The bullseye is then deployed by panel hinge actuation. A rover may be used to secure the apron rim to the ground using soil anchors.

The Skinny may alternatively be lowered to the surface by the maiden lander while hovering above the altitude that creates ejecta. This would require an unconventional engine configuration combined with a wire system to lower payloads. This may eliminate the need for a crane to pick and place the artifact from the payload bay of a lander onto the surface and may enable said vehicle to land on the pad it deploys.

THE MACHINE

FEATURE-RICH, IMPORTED LUNAR SPACEPORT

- | | | | | |
|---------------------|--------------------|------------------------|---------------------|----------------------|
| a. refueling arm | e. engine exhaust | i. payload integration | o. lift point | t. terminal grille |
| b. descent beacon | f. payload fairing | l. lander | p. hinged petals | u. fuel/ power lines |
| c. stowed config. | g. landing gear | m. main deck | r. rover payload | w. sitework ramp |
| d. exhaust gas duct | h. arm hatch | n. engine nozzle | s. structural frame | y. subsystems |

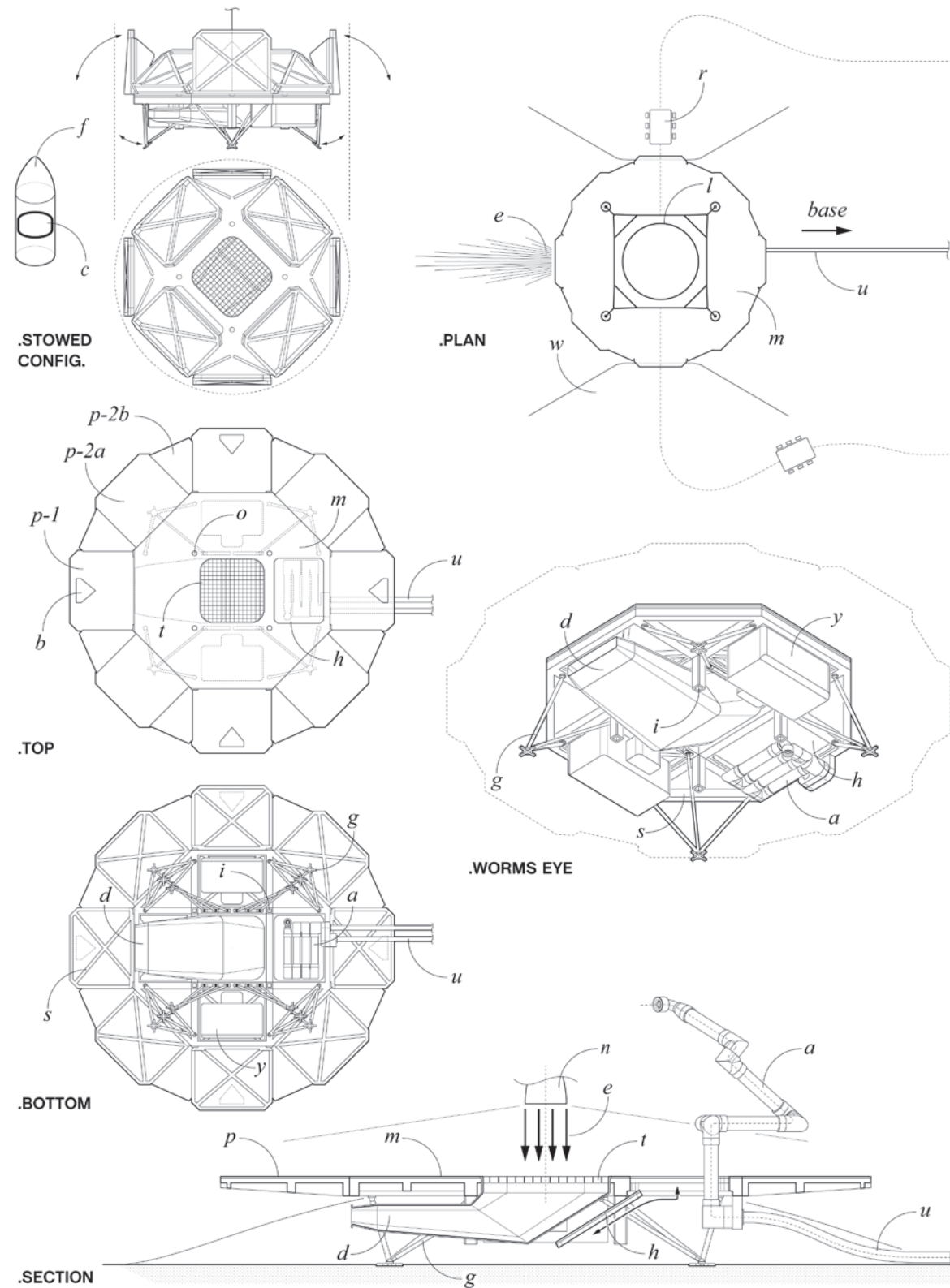

by Jeffrey Montes with Open Lunar Foundation

The Machine is a feature-rich spaceport imported from Earth and deployed on the lunar surface. It offers visiting vehicles additional services and protection.

Architecture

Featuring subsystems and landing gear, The Machine is a spacecraft unto itself. It is elevated above the ground on legs, which earns it volume under the deck for an exhaust duct. This duct captures the exhaust gases in continuum and transitional flow and redirects them down and laterally away from the lander, protecting it. A hatch on the main deck conceals a robotic arm the offers automated refueling and/or recharging for a visiting vehicle. Since it interfaces directly with fuel and power lines, it removes the need and associated risk for other vehicles to refuel each cycle. Due to its elevation off of the ground and the dimensional constraints of stowage, it does not have an extended apron to protect the ground from lower energy exhaust.

CONOPS

Delivered to the lunar surface as lander payload, it is hoisted from the lander using a crane. The legs deploy from their stowed position prior to placement on an ideal or prepared (leveled and flattened) site. Once on the surface, the platforms open via panel hinge actuation. An existing utility vehicle connects power and fuel lines from the base.

The Machine may alternatively be lowered to the surface by the maiden lander while hovering above the altitude that creates ejecta. This would require an unconventional engine configuration combined with a wire system to lower payloads. This may eliminate the need for a crane to pick and place the artifact from the payload bay of a lander onto the surface and may enable said vehicle to land on the pad it deploys.

THE BRUTE

FEATURE-POOR, IN-SITU MADE LUNAR SPACEPORT

- | | |
|--------------------------|--------------------------|
| <i>a. printed ramp</i> | <i>n. engine nozzle</i> |
| <i>b. berm</i> | <i>p. printed pad</i> |
| <i>e. rocket exhaust</i> | <i>r. rover payload</i> |
| <i>l. lander</i> | <i>m. sitework mound</i> |

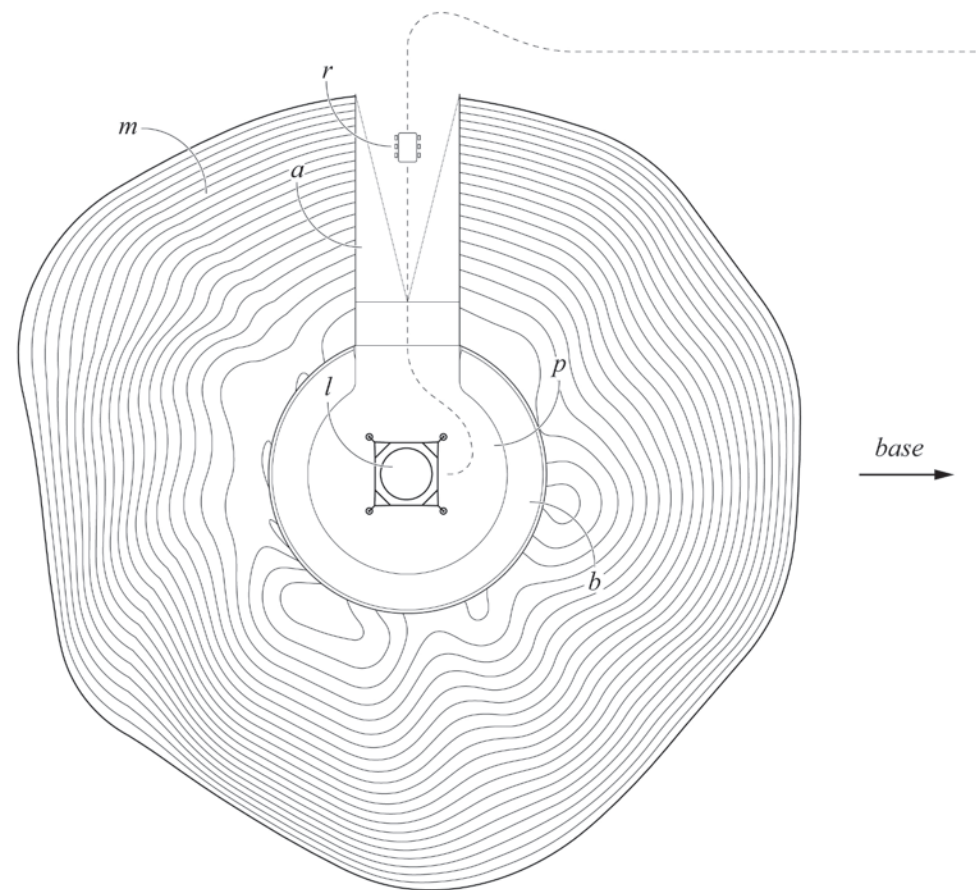

.PLAN

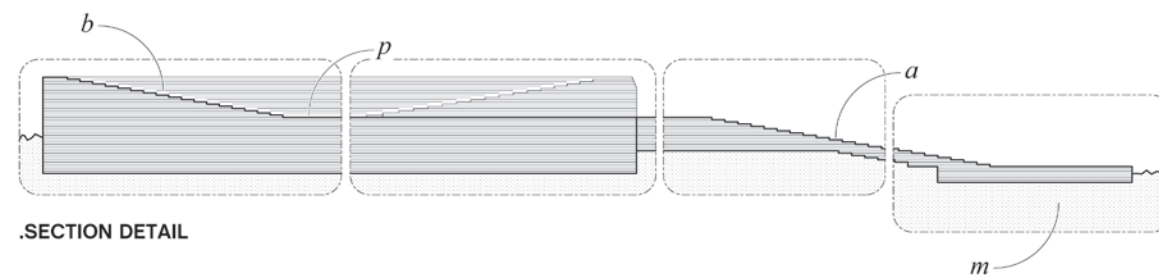

.SECTION DETAIL

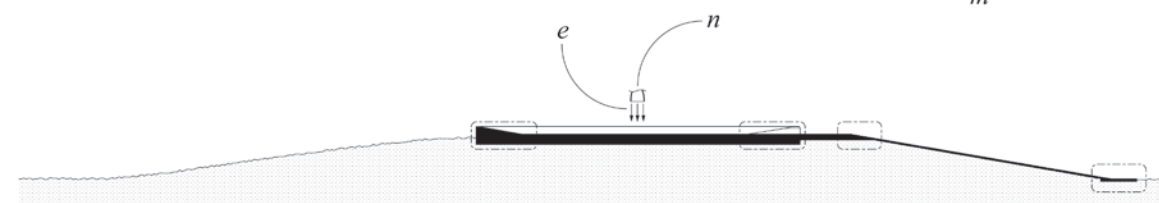

.SECTION

by Jeffrey Montes with Open Lunar Foundation

The Brute is a simple in situ-made spaceport. It performs the essential function of a spaceport.

Architecture

The Brute consists of a printed pad elevated on a mound of regolith with a road leading up to it. The pad is made of a single material and process: additively constructed high-temperature polymer. A promising candidate is geopolimer, inorganic ceramics that can be made of silicon, oxygen, aluminum, and iron (all found on the Moon). The pad has an upturned profile, ensuring that high velocity gases and ablated material do not induce shear forces on the down-sloped mound. The road, not required to sustain the acute thermal and mechanical loads of the engine exhaust, can be made from a less resilient polymer. The slope of regolith mound is likely driven by the maximum desire slope of the road.

CONOPS

After a site is selected, a mound is created using regolith - ideal volumes that have already been excavated for base-building purposes. After the desired height and slope is reached, construction of the road begins, layer by layer, up the slope. Once the road is completed, the same robotic printer can park at the top of the road and print the pad. Once complete, the printer reverse down the road it printed.

THE WORKS

FEATURE-RICH, IN-SITU MADE LUNAR SPACEPORT

| | | | |
|---------------------|-----------------------|--------------------|-------------------------|
| b. landing beacon | f. exhaust funnel | n. engine nozzle | r. road |
| c. sett crown | g. gripping socket | o. sett root | t. fluids/ gas terminal |
| d. exhaust gas duct | i. regolith infill | p. propellant line | w. printed wall |
| e. engine exhaust | l. lander (for scale) | s. sett | z. landing pad zones |

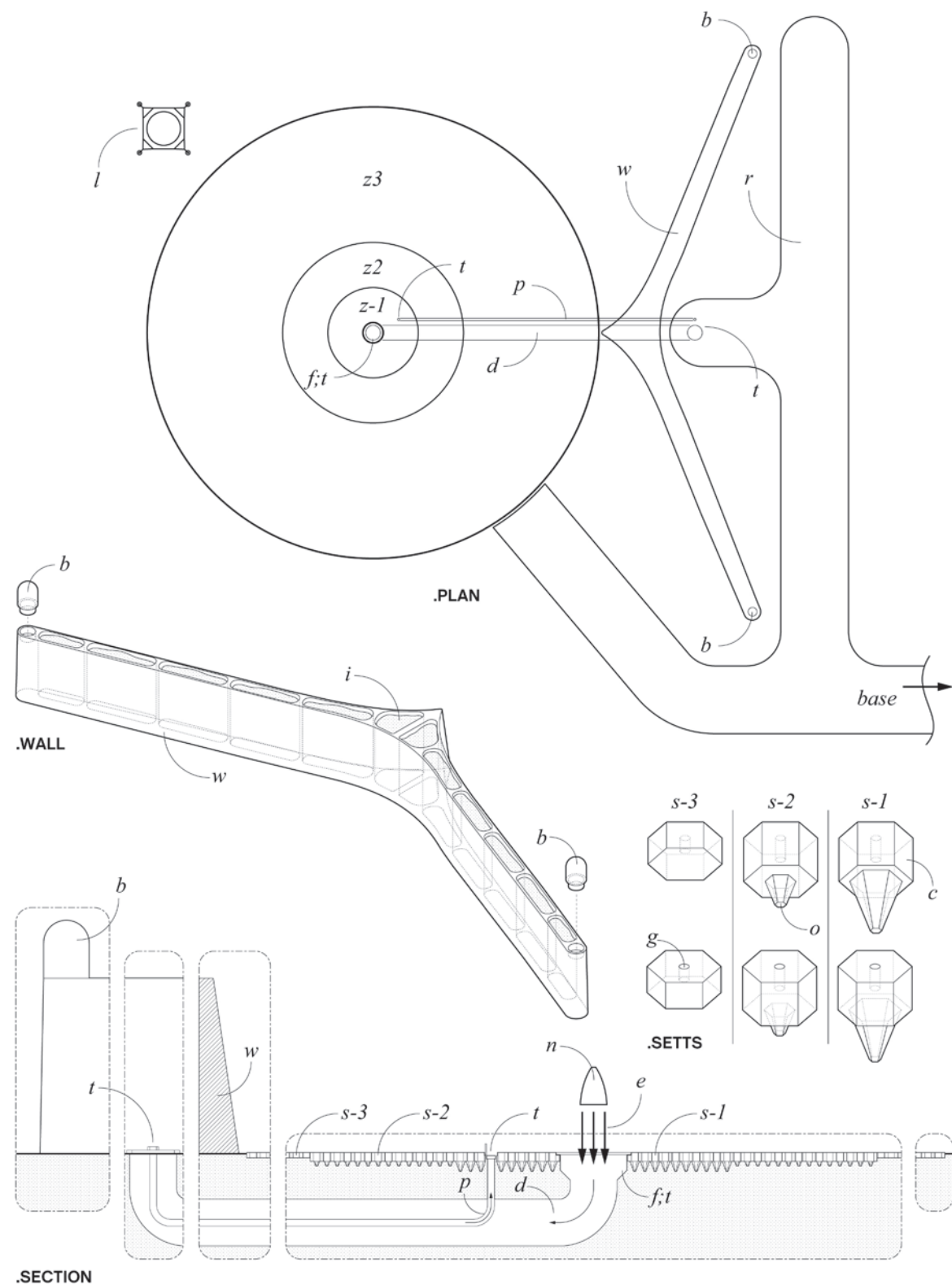

by Jeffrey Montes with Open Lunar Foundation

The Works is a full-featured, in-situ made spaceport. It requires a proper civil engineering effort.

Architecture

The Works consists of an intricate, multi-zone pad, an ejecta shield, and subterranean systems for refueling and capturing exhaust gases all connected with roads. The pad is constructed in three zones made of grouted, oven-sintered basalt setts (deep blocks) of varying depth. The ejecta shield is additively constructed from polymer and made with integrated voids which backfilled with regolith. A subterranean pipe, assembled from segments, is used to direct engine exhaust to where it might be captured, protecting the lunar vacuum from contamination.

Setts are laid in a hexagonal grid with the deepest in the central zone and the shallowest in the outer zones. Their heft, hardness and depth into the ground make them resistant to cracking, wear, and dislodging. The gaps between the setts are injected with liquid geopolymer that sets in place, creating a seal that prevents the high-pressure exhaust gases from disassembling the setts. Geopolymers would offer unrivaled fire-resistance and may be best suited for the central zone. Less resistant polymers may be used for the ejecta shield and outer zone grouting.

CONOPS

Roads are completed first to mitigate dust. Setts are removed from their ovens onto a pallet, which is loaded until full. In parallel, an excavator digs a trench for the subterranean fuel line and exhaust pipe. The fuel line (likely imported from Earth) and the pipe are laid in the trench and covered. The roads are made by removing regolith overburden leaving a hard layer which can be optionally paved or covered.

The first pallet of setts is moved to a prepared (leveled and flat) site where a sett-laying machine places them into or onto the ground. After all setts are laid, a robotic printer filling the gaps with grout. The same printer used to grout the setts can be used to print the wall, whose hollow cavities are filled with regolith by a conveyor/ excavator.

Notes

Ejecta shields

A well designed and sufficiently large pad combined with a perfect landing (vertical descent from the a non-ejecta-blowing distance and laterally accurate) does not need an ejecta shield. However, accidents happen. Vehicles may explode and engines may malfunction, causing a crash that threatens the base and its inhabitants. Once the exhaust plume leaves the continuum flow regime, it enters into free molecular flow, where it tends to bounce and scatter rather than flow. In this situation, shields may reflect high-velocity gases and ejecta back at the vehicle.

Lander design

When engines turn off during landing, the release of pressure in the load on the pad may liberate material and cause it to shoot upwards. This is a reason to armor the bottom of the lander.

Engine configuration can have a big effect on the thermal and mechanical loads on a pad. For example, laterally mounted, canted, raised or multiple smaller engines can reduce or favorably distribute these loads.

Assumptions

Time span

The most challenging design (The Works) is bounded at 2120, 100 years from this writing.

Lunar scarcity

Regardless of their position on the design space plot, each design is bounded by the limitations of a world of inherent scarcity, the Moon. Indeed, any artifact on the lunar surface is inevitably bound by scarcity. The rocket equation guarantees this for imported artifacts. For in situ-made artifacts, this is based in a unique geological reality. What is valuable on the Moon is locked in rocks found in a high entropy distribution on the surface. This applies equally to water: The Moon may have many gigatons of water but that water is dirty, in low concentrations, and scattered. Because the Moon lacks hydrological, aeolian, or biological processes that pool, collect, deposit, separate, and concentrate raw materials, it is a land of functional scarcity.

Landing Precision

Vehicle guidance, spatial awareness and landing accuracy and precision has been perfected to a landing tolerance of 1 meter.

Conclusions

All spaceports in the design space leverage a set of technologies and practices that will be required for any lunar future: sitework. Sitework includes excavating, leveling, and moving large volumes of regolith. If the sitework required for the different designs is more similar than the designs are, this could translate to lower long term cost for in-situ spaceports. Multiple simple spaceports can be traded against investing in a fully featured one.

Lightweight, imported spaceports could mean that every large mass lander could be required to ride share with one that self-lands or is lowered down to the surface prior to landing. There is more work to be done to explore dust mitigation approaches implied within this technology direction, such as the dis-incentive structure associated with user-pays.

Larger, more complex, spaceports would prompt cooperative use to bring down the per user cost. This may be interesting to explore in the small regions with concentrations of resources deemed valuable with the combined intent to protect the precious areas, and enable greater ease of access to such a unique location.

Design spaces deserve to be used more frequently by the lunar infrastructure industry to help collaborate on which problems are worth solving in which ways before commitment to greater R&D.

Designing in the open can help the lunar community realize what problems are

worth solving together.

All design directions imply socio-economic incentive structures regarding cost and benefit sharing, which deserve greater attention. These initial directions may provide a starting point for such an analysis.

References

- Metzger, P., Smith, J., Lane, J., (2011) *Phenomenology of soil erosion due to rocket exhaust on the Moon and the Mauna Kea lunar test site*. Journal of Geophysical Research: Planets 116, no. E
- Montes, J., Schingler, J.K., Metzger, P. Pad for Humanity: Lunar spaceports as Critical Shared Infrastructure, Proc. of the 17th Int'l Conf. on Eng'g, Sci., Constr. & Operations in Challengeing Env's. (2020).
- NASA's Lunar Exploration Program Overview (September 2020), NASA, <https://www.nasa.gov/specials/artemis/>
- Susskind, L., Hrabovsky, G., *The Theoretical Minimum*. Basic Books, 2014.
- Heiken, Grant H., David T. Vaniman, and Bevan M. French. *Lunar Sourcebook: A User's Guide to the Moon*. Cambridge University Press, 1991.
- Van Susante, Paul and Metzger, Phillip T. *Design, Test and Simulation of Lunar and Mars Landing Pad Soil Stabilization Built with In-Situ Rock Utilization* (2016). ASCE Earth and Space, Orlando, FL
- Tosh, Abhijit, Peter A. Liever, Robert R. Arslanbekov, and Sami D. Habchi (2011). Numerical analysis of spacecraft rocket plume impingement under lunar environment. Journal of Spacecraft and Rockets 48(1): 93-102

This work is the result of a 2019-2020 research fellowship at Open Lunar Foundation. I am grateful to OLF for their support and for their brave commitment in putting forth smart, pragmatic, and actionable models for our collective Space future.

I am also grateful to the growing OLF community and especially to Chelsea Robinson and Jessy Kate Schingler.



OPEN LUNAR
FOUNDATION