

Before you start assembling the sauna, please read the entire manual.  
All units of measurement are in millimeters.  
A sauna barrel can never be 100% tight due to the construction.

Bevor Sie mit der Saunamontage beginnen, lesen Sie bitte die ganze Anleitung durch.  
Alle Maßeinheiten sind in Millimeter angegeben.  
Ein Saunafass kann durch die Bauweise nie zu 100% dicht sein.

**Serial No. : 113ILH1-\_\_\_\_\_**





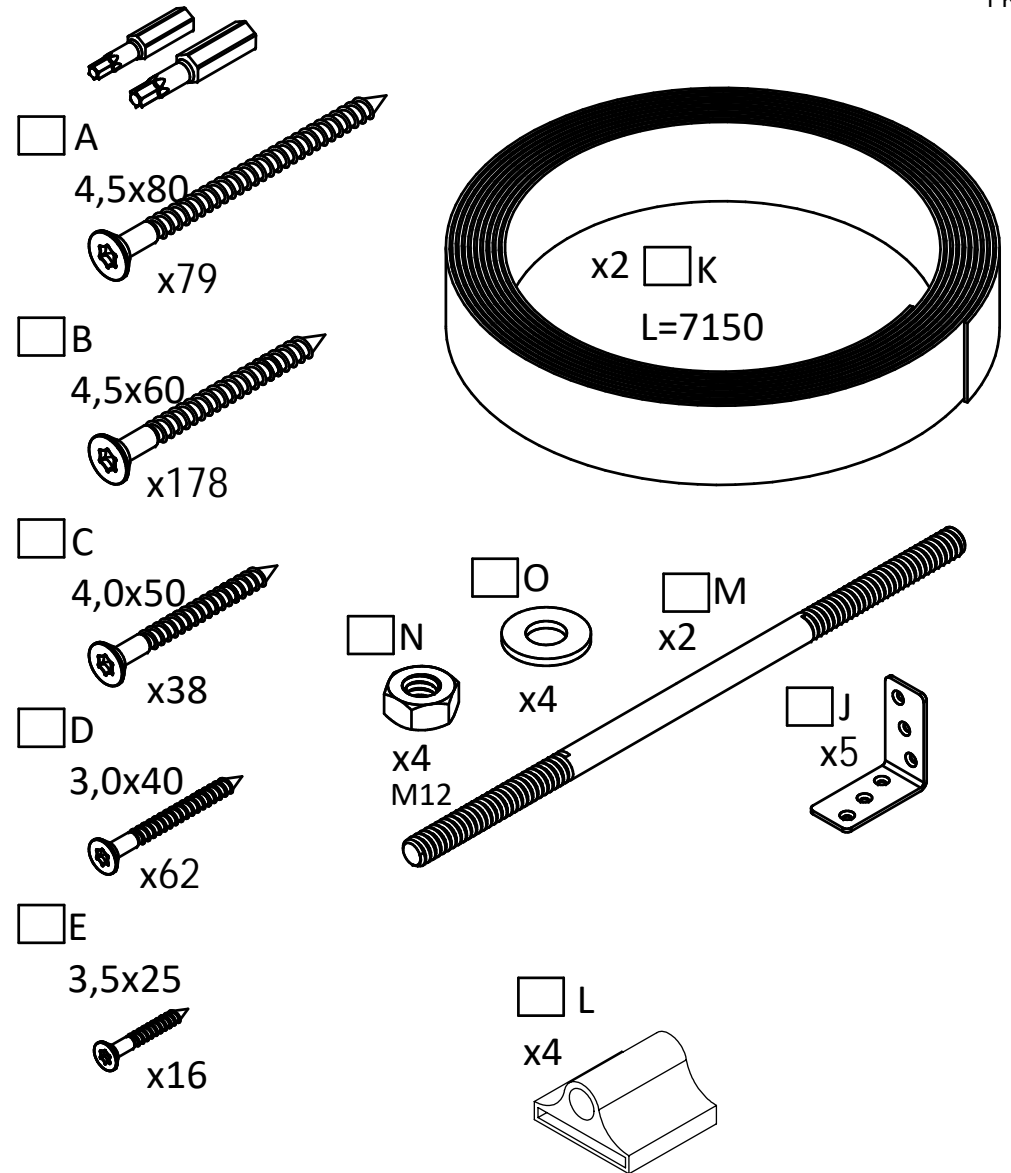
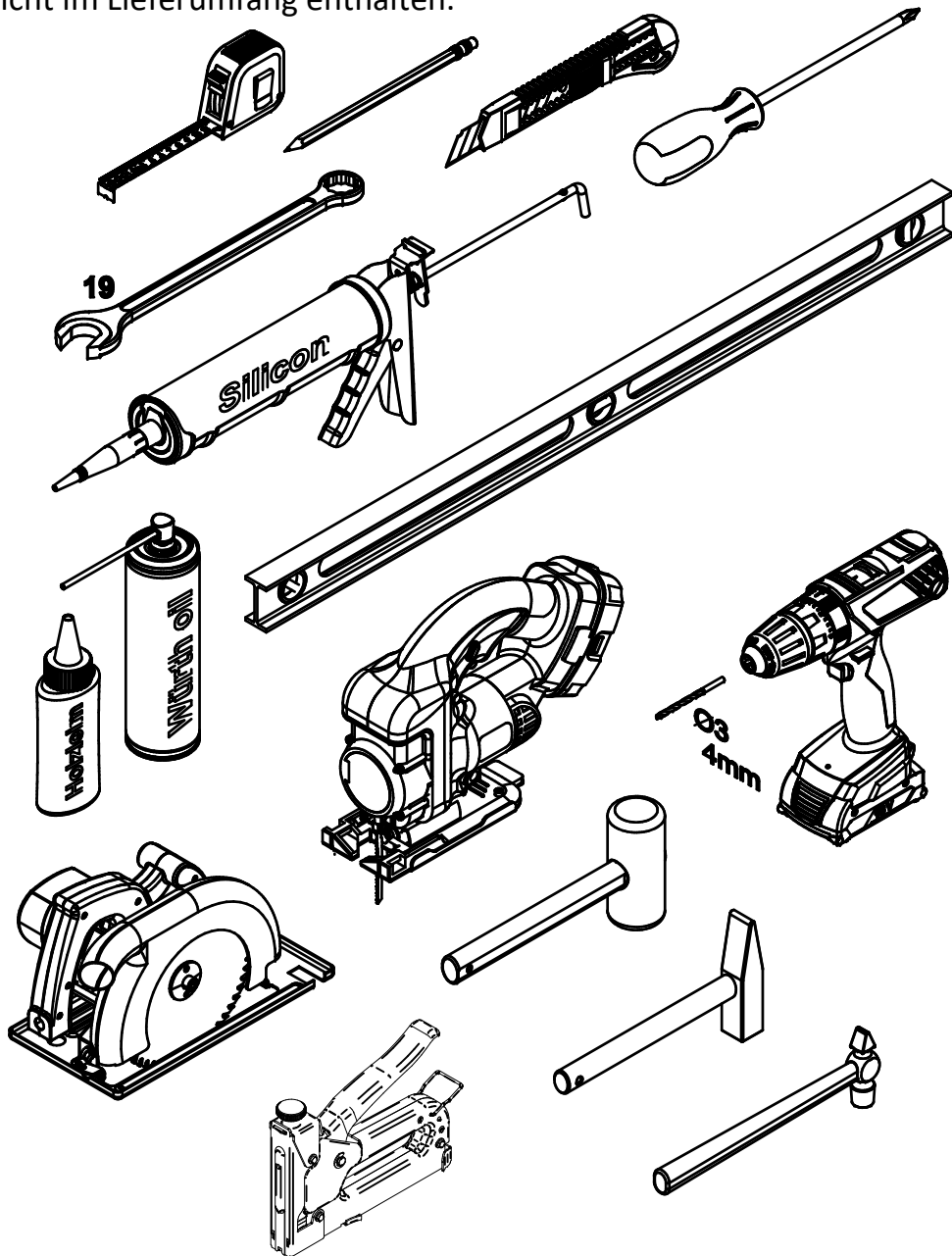







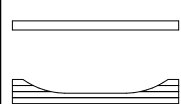
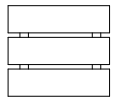
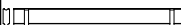
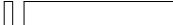

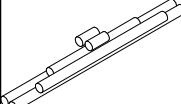
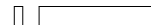

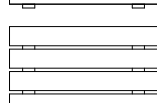



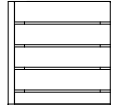
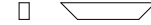

rev: 01  
IL113H1-2-00



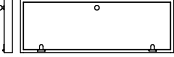

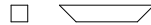
Tools that make your construction easier.  
 Not included in the delivery.  
 Werkzeuge, die Ihren Aufbau erleichtern.  
 Nicht im Lieferumfang enthalten.

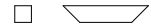



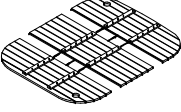
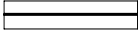
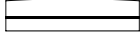
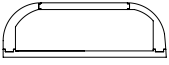
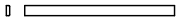

# BASE

07.05.25

No.	L x W x H	Qt		No.	L x W x H	Qt		No.	L x W x H	Qt	
1	1700x160x60	2		85a	400x302	1					
3	42x103x1130	68 +1		86	575x90x28	1		95	809x44x44	2	
21	D24	kit		87	396x90x28	3		96	813x44x44x2	2	
71	700x408	1		88	605x90x28	3		97	334x44x44	2	
81	1855x450x90	1		89	450x90x28	1		98	120x44x44	3	
82	480x450x90	1		90	300x40x28	1		99	60x28x28	10	
83	780x205x90	1		91	378x44x44	1		101	1690x590x100	1	
84	433x205x90	1		92	300x44x44	1		102	1670x44x18	2	
85	1485x408	1		93	250x44x44	3		103	660x44x18	2	

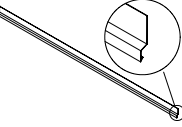
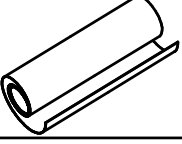
No.	L x W x H	Qt		No.	L x W x H	Qt	
104	1690x28x28	2		901	Lüftungsgitter Air grille	3	
105	646x28x28	2		902	Lüftungsgitter Air Grille	1	
511	1955x1300x28	1					
621	610x115x28	1	 Bottom				
622	610x132x28	1	Top 				
623	Plywood glass frame	1L 1R					
E1	1850mm board	3					

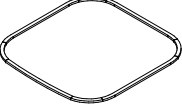
Optional

No.	L x W x H	Qt	
4	1130	2	
141	3600x1500	1	
142	L1000x320	43	
143	L1000x250	2	
151	Holz Arch	kit 2x	
H	Nagel Nail	kit	

# FOUNDATION PLAN FUNDAMENTPLAN

Use a spirit level  
Benutzen Sie eine Wasserwaage

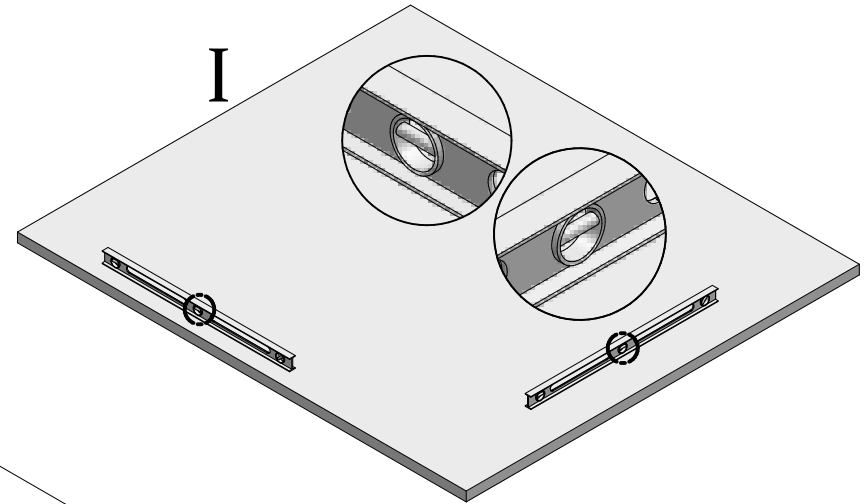

II

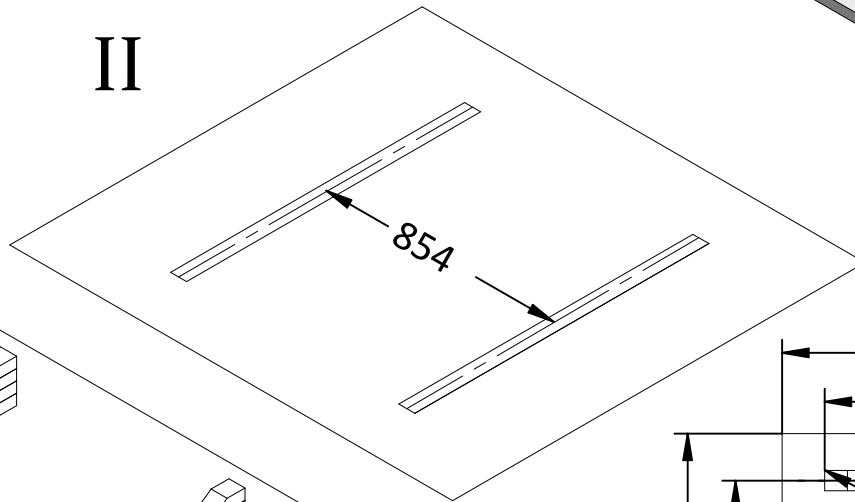

III

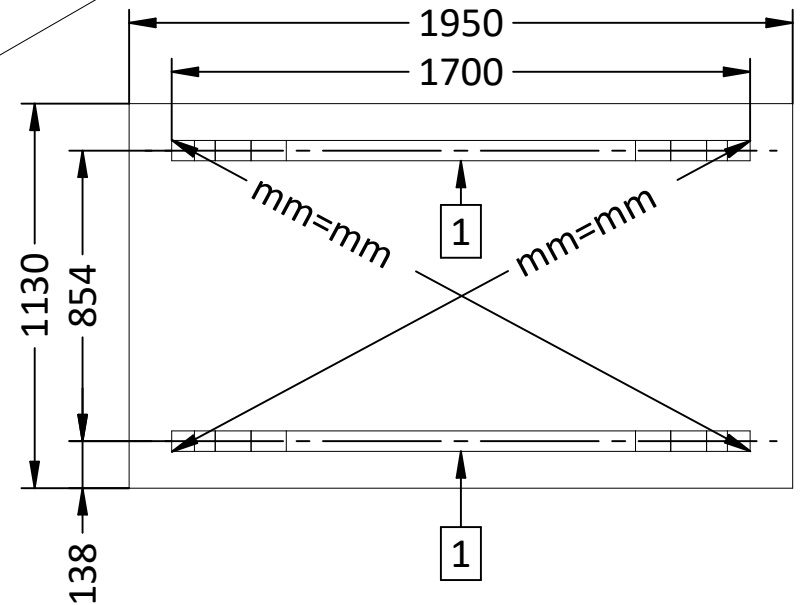
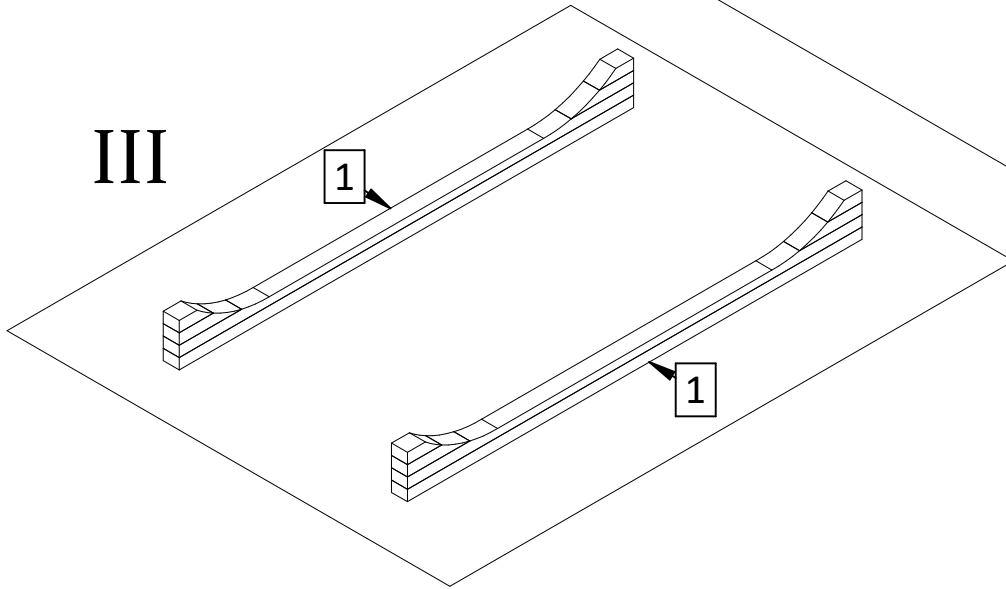

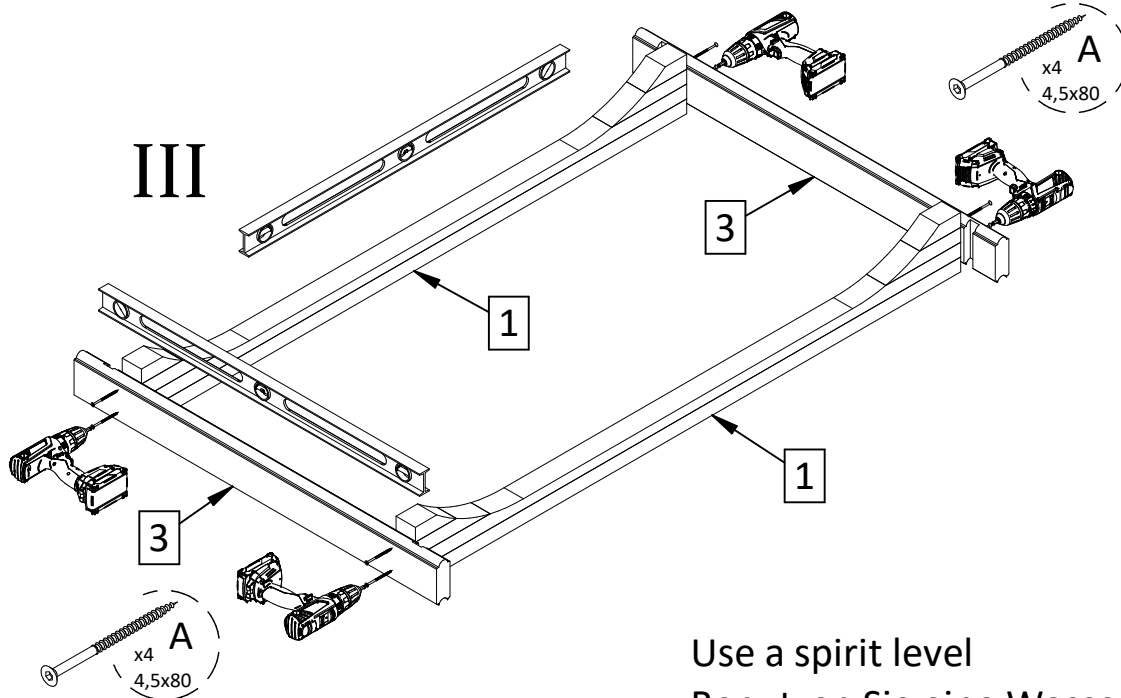
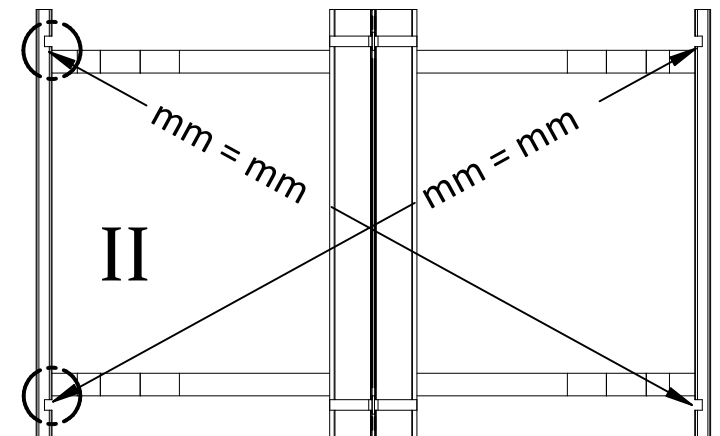
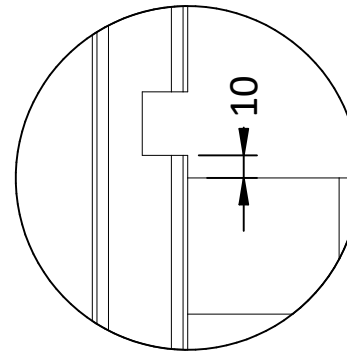
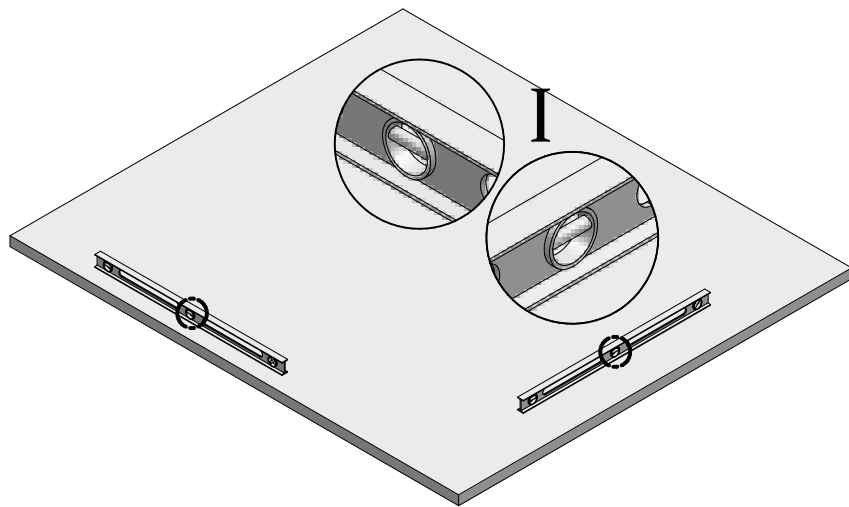

Use a spirit level  
Benutzen Sie eine Wasserwaage

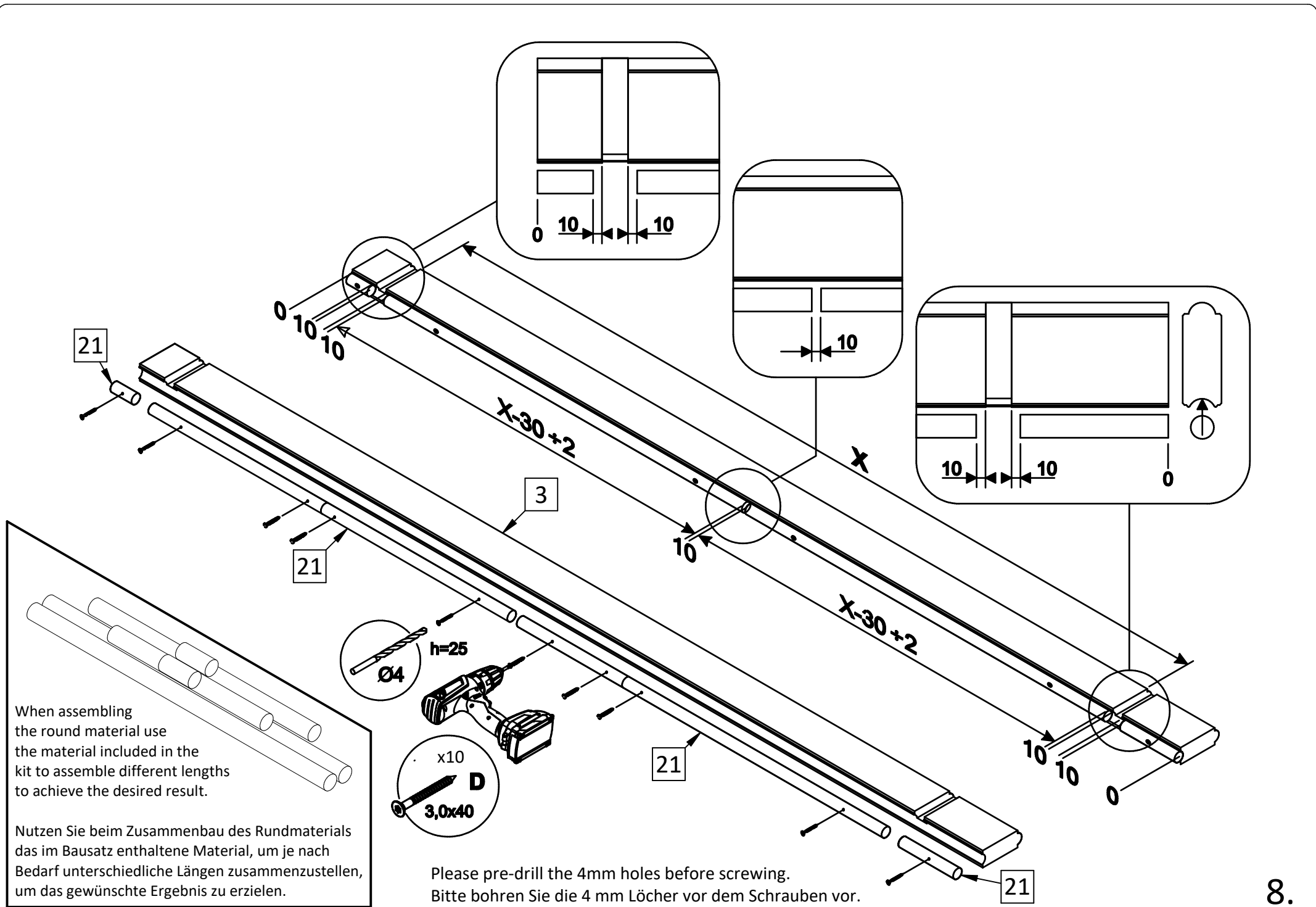

When assembling the round material use the material included in the kit to assemble different lengths to achieve the desired result.

Nutzen Sie beim Zusammenbau des Rundmaterials das im Bausatz enthaltene Material, um je nach Bedarf unterschiedliche Längen zusammenzustellen, um das gewünschte Ergebnis zu erzielen.

Please pre-drill the 4mm holes before screwing.  
Bitte bohren Sie die 4 mm Löcher vor dem Schrauben vor.

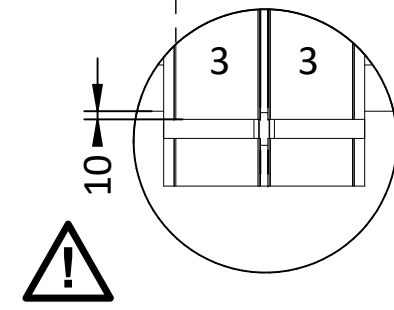
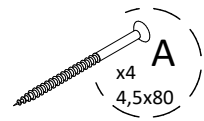
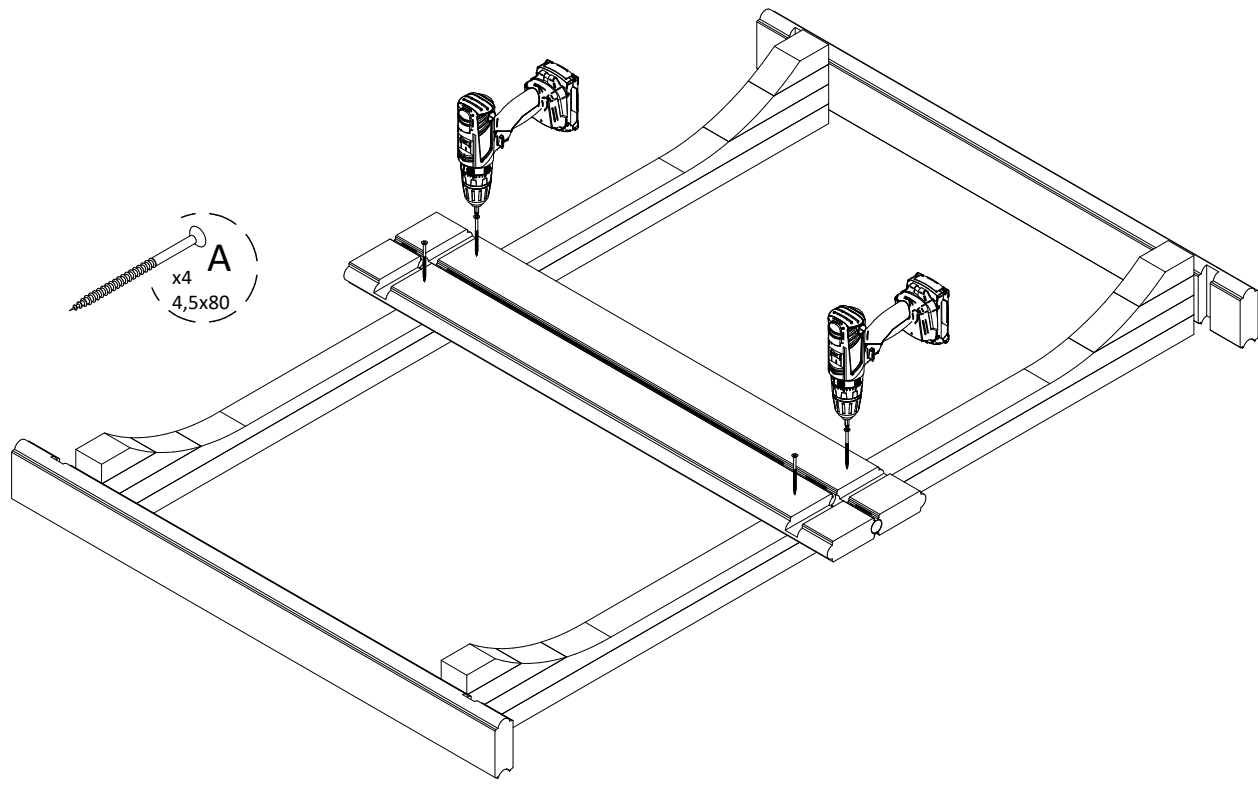
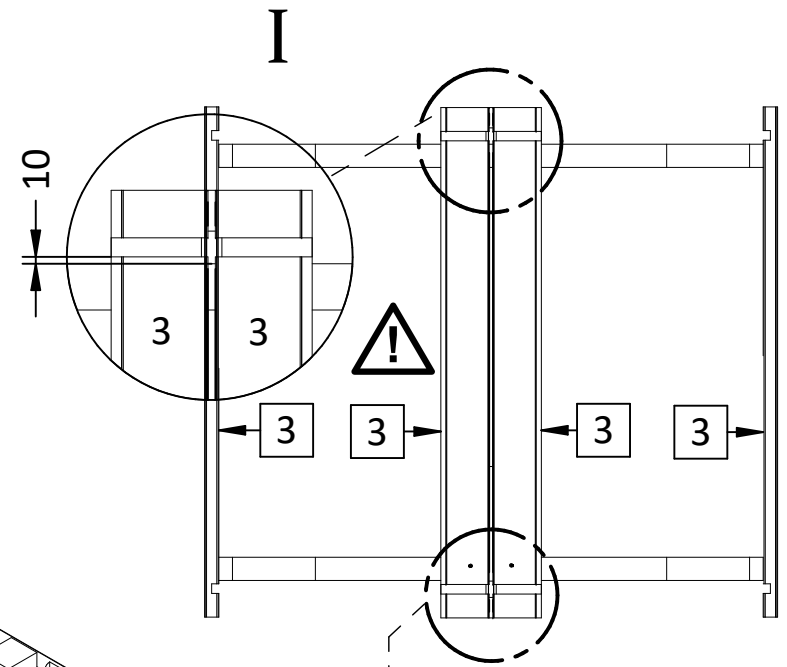
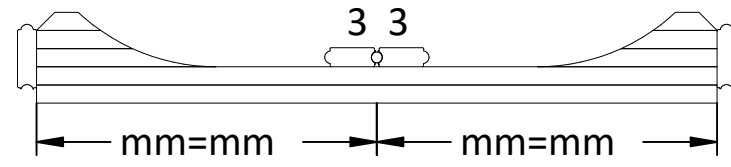
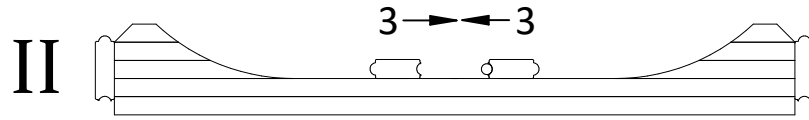

Use a spirit level  
Benutzen Sie eine Wasserwaage

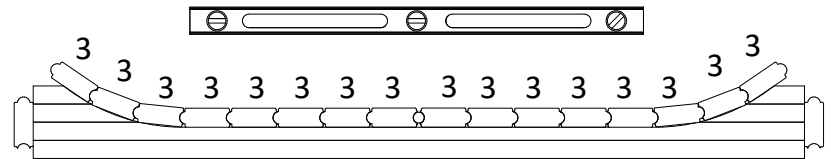
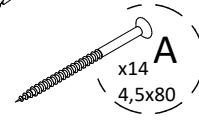
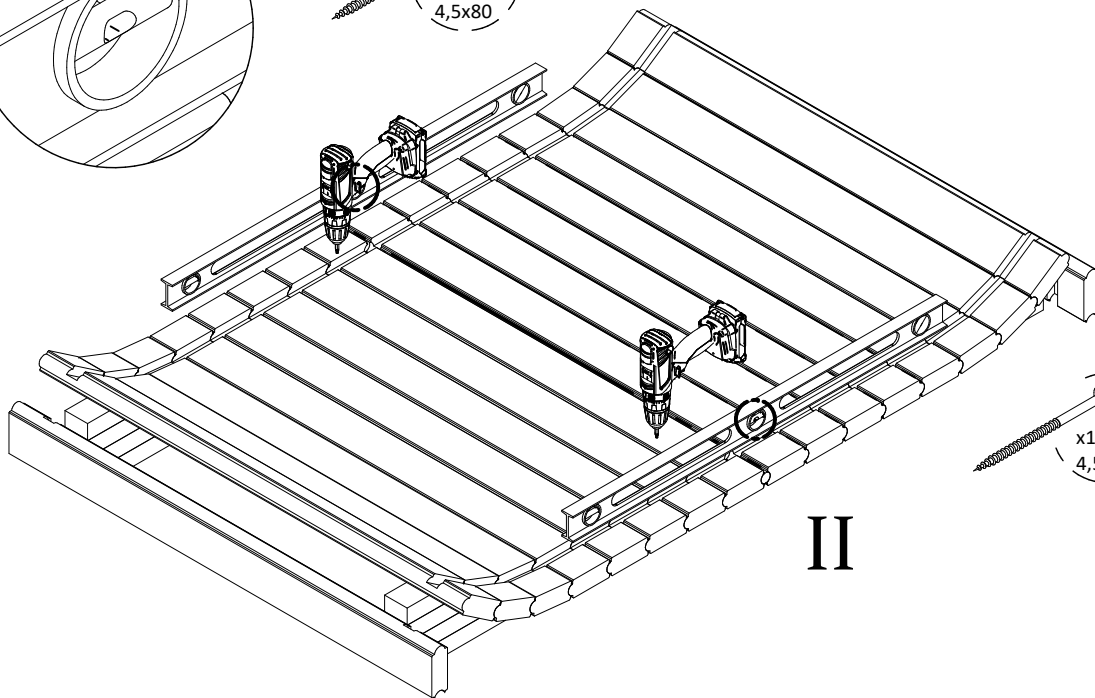
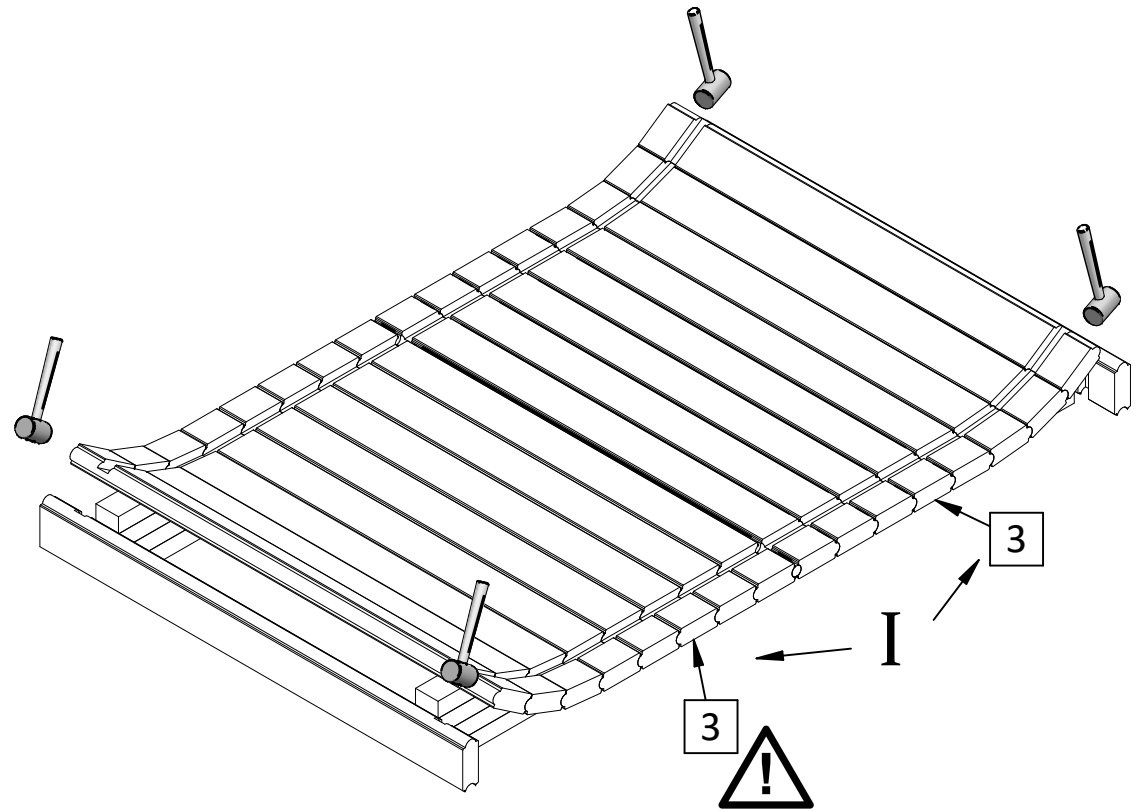
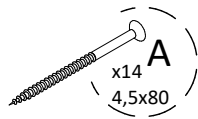
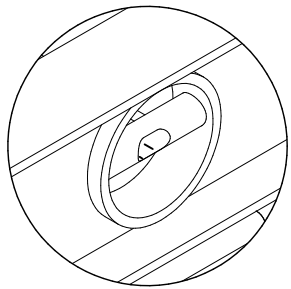

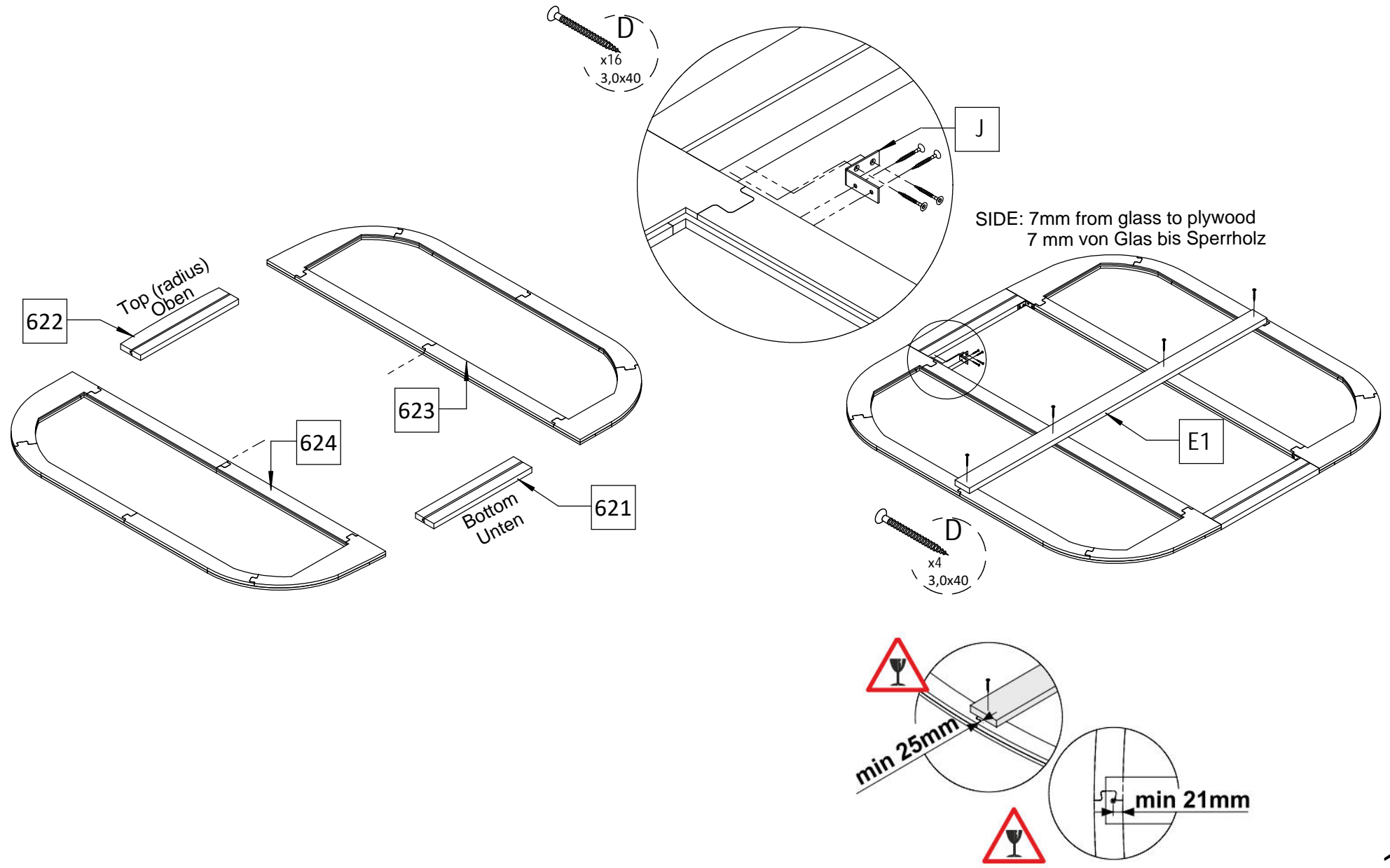

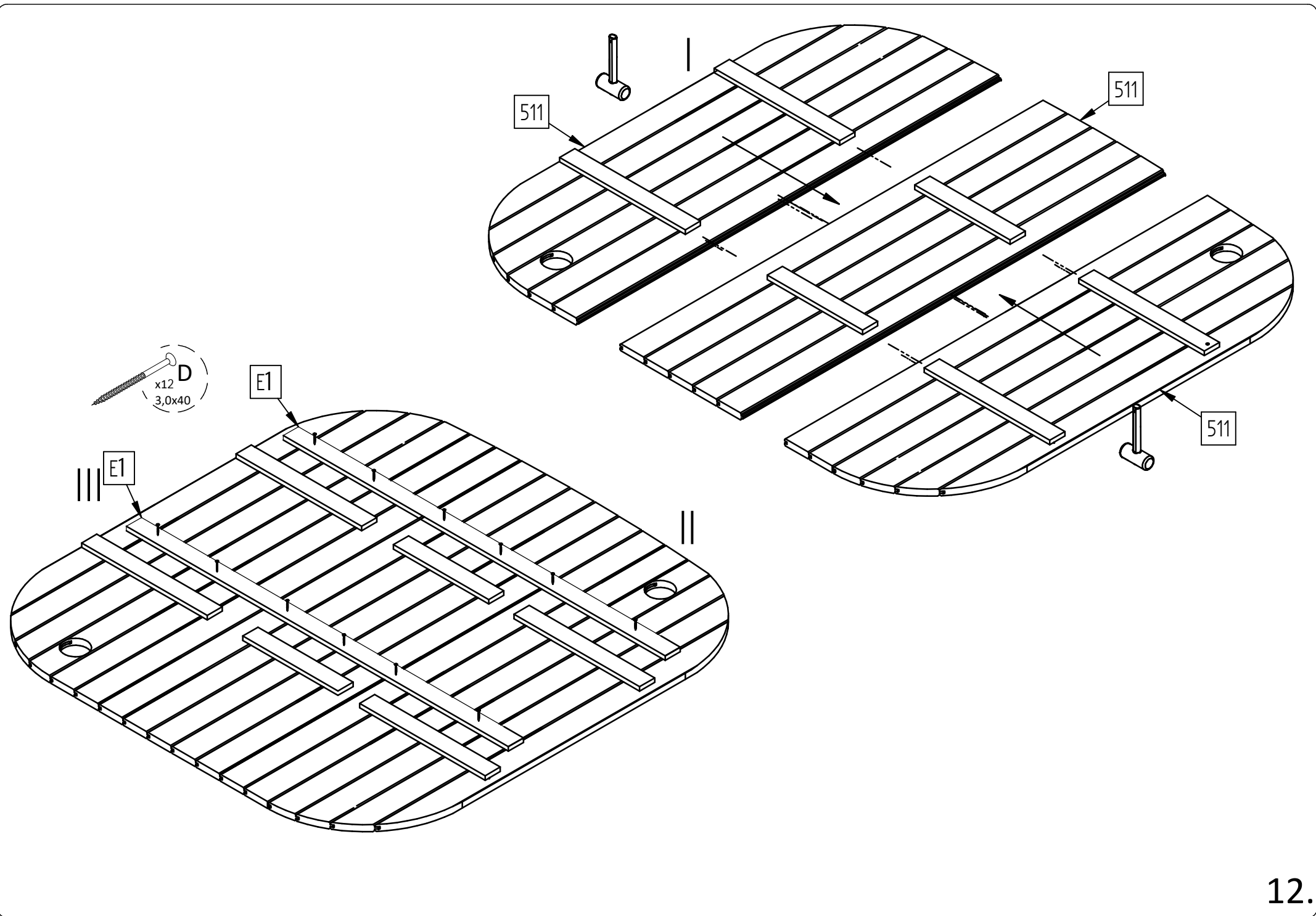

Use a spirit level  
Benutzen Sie eine Wasserwaage

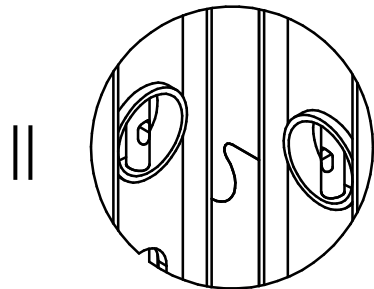

621-624

Important! Keep your distance!  
Don't leave a gap if  
the sauna is made of  
thermowood.



Wichtig! Abstand halten!  
Keine Lücke lassen,  
falls Sauna aus Thermoholz ist.

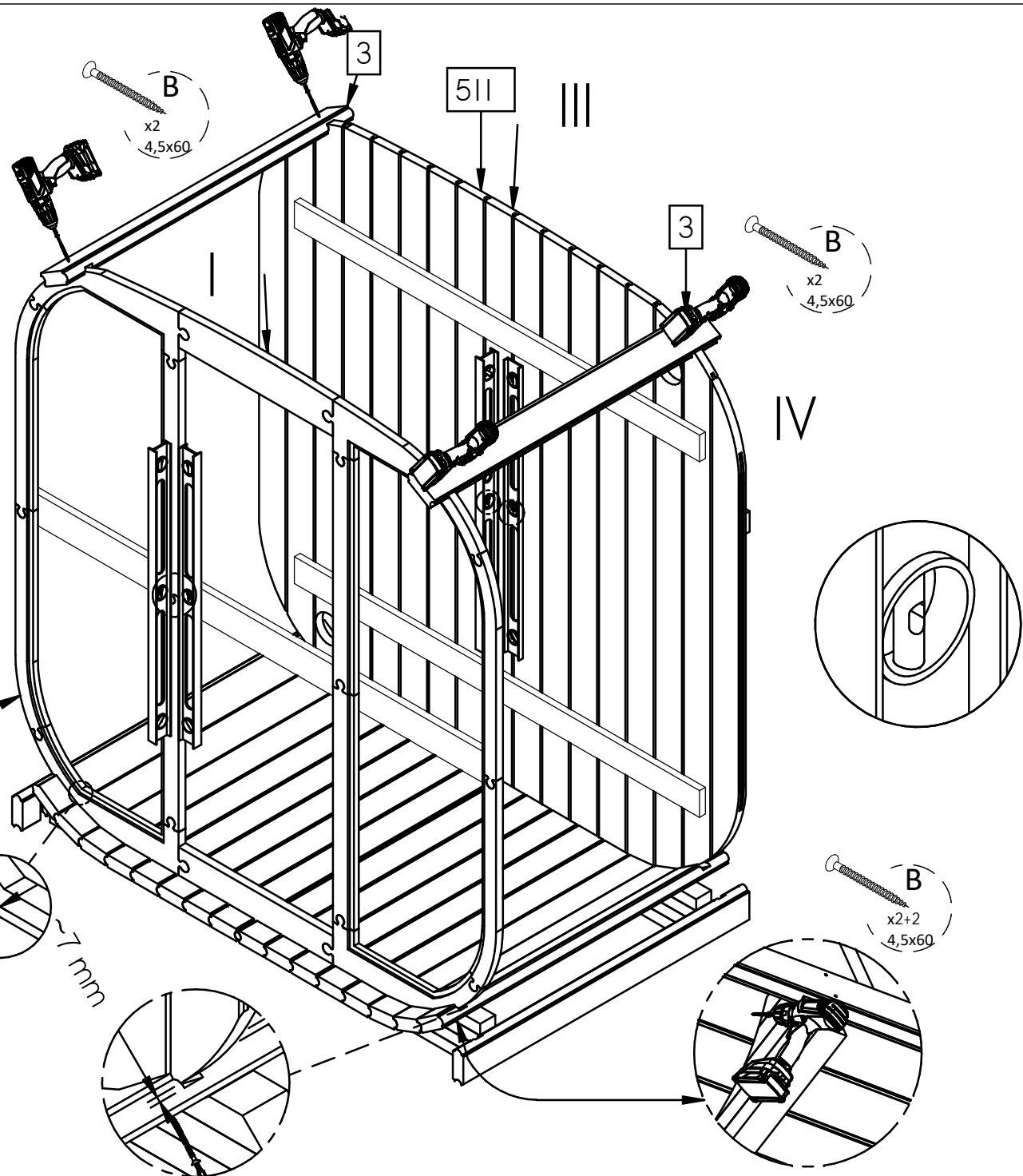
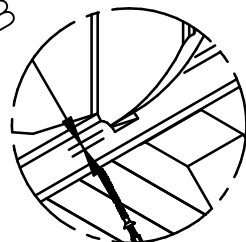
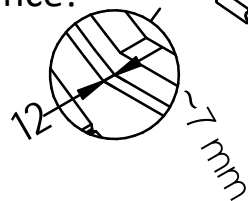

Important! Keep your distance!  
Don't leave a gap if  
the sauna is made of  
thermowood.

Wichtig! Abstand halten!  
Keine Lücke lassen,  
falls Sauna aus  
Thermoholz ist.

Remove the screws.  
Die Schrauben entfernen.

Important! Please remove  
the screws and use them  
for further assembly.

Wichtig! Bitte entfernen Sie  
die Schrauben und benutzen sie  
die bei der weiteren Montage

Remove the screws.  
Die Schrauben entfernen.

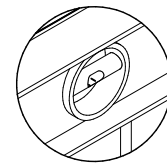
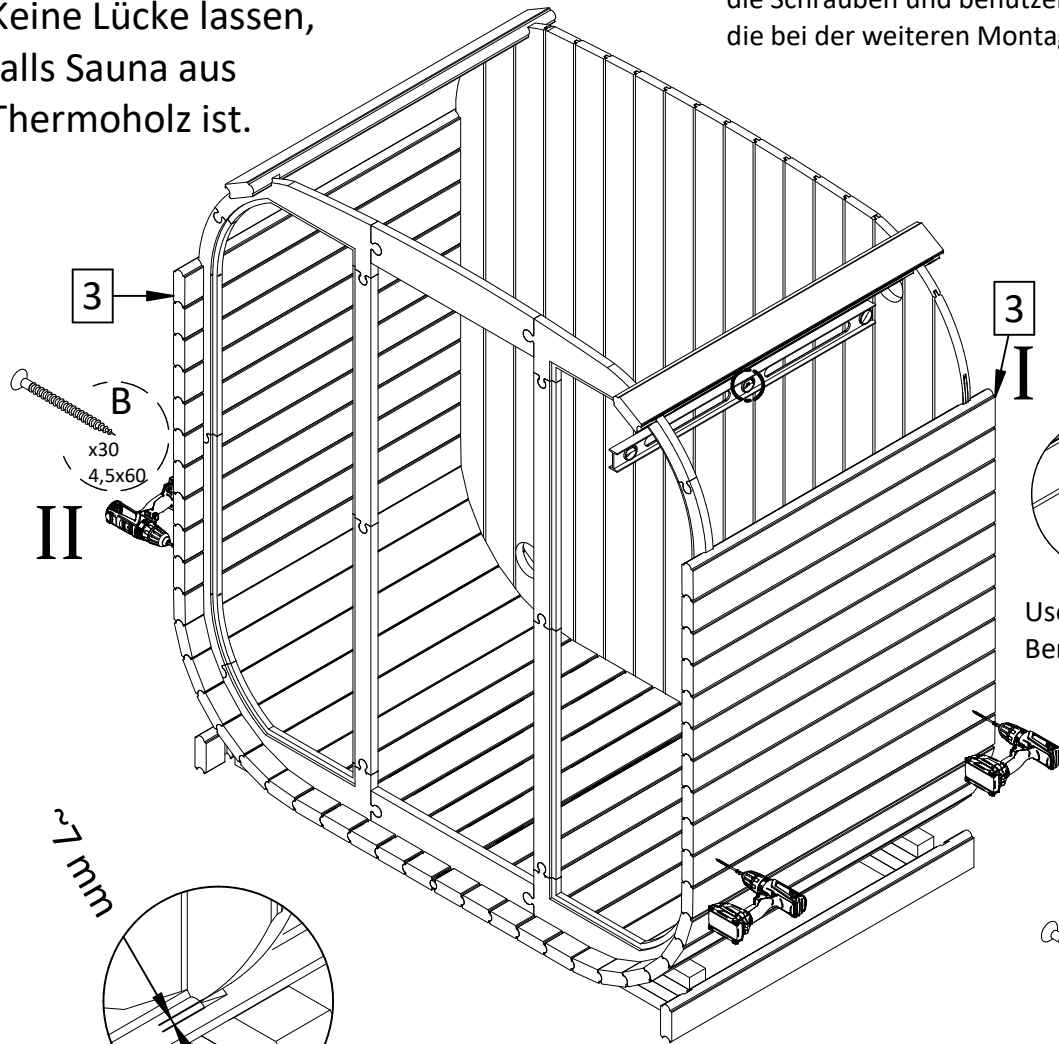

Use a spirit level  
Benutzen Sie eine Wasserwaage

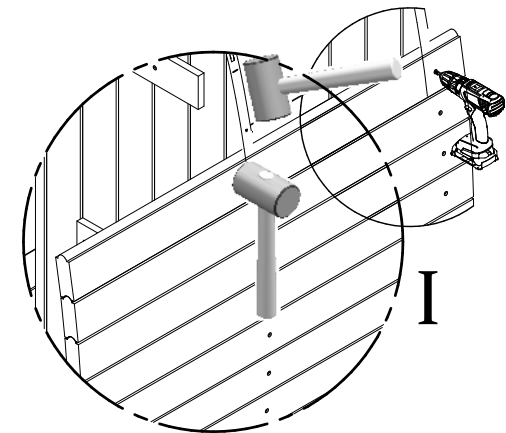
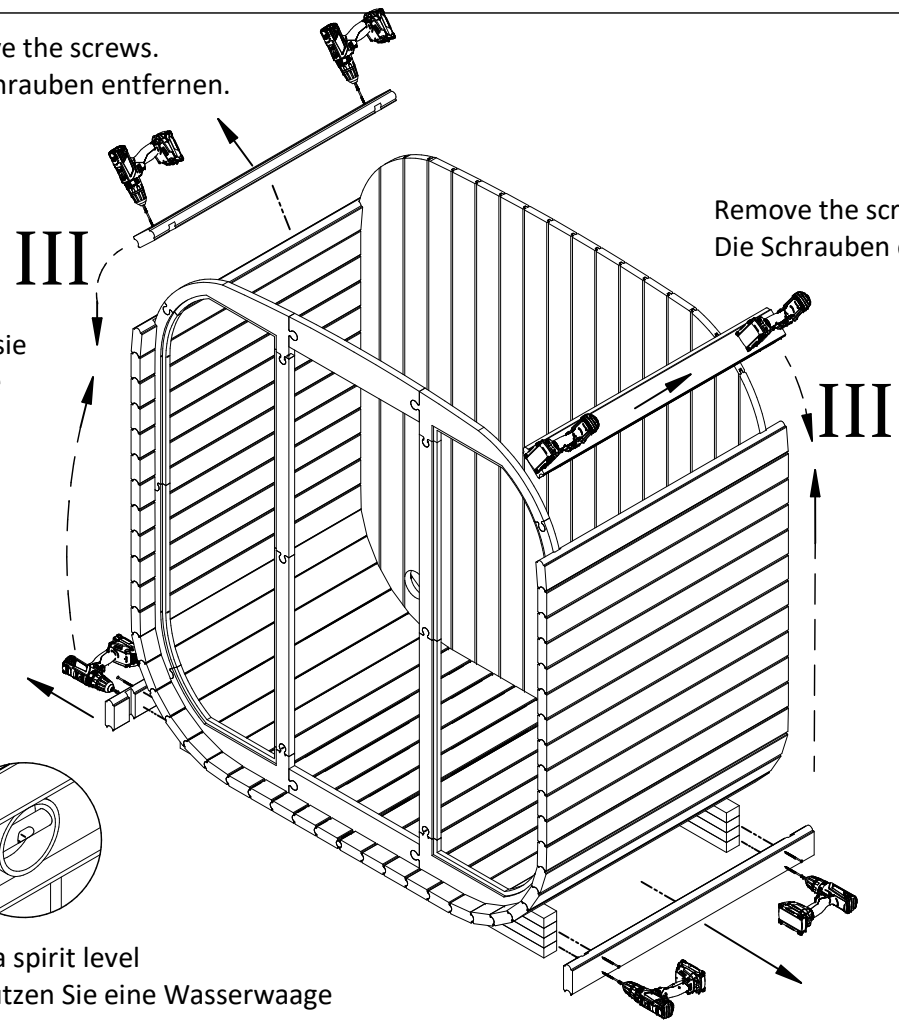
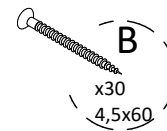

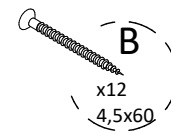
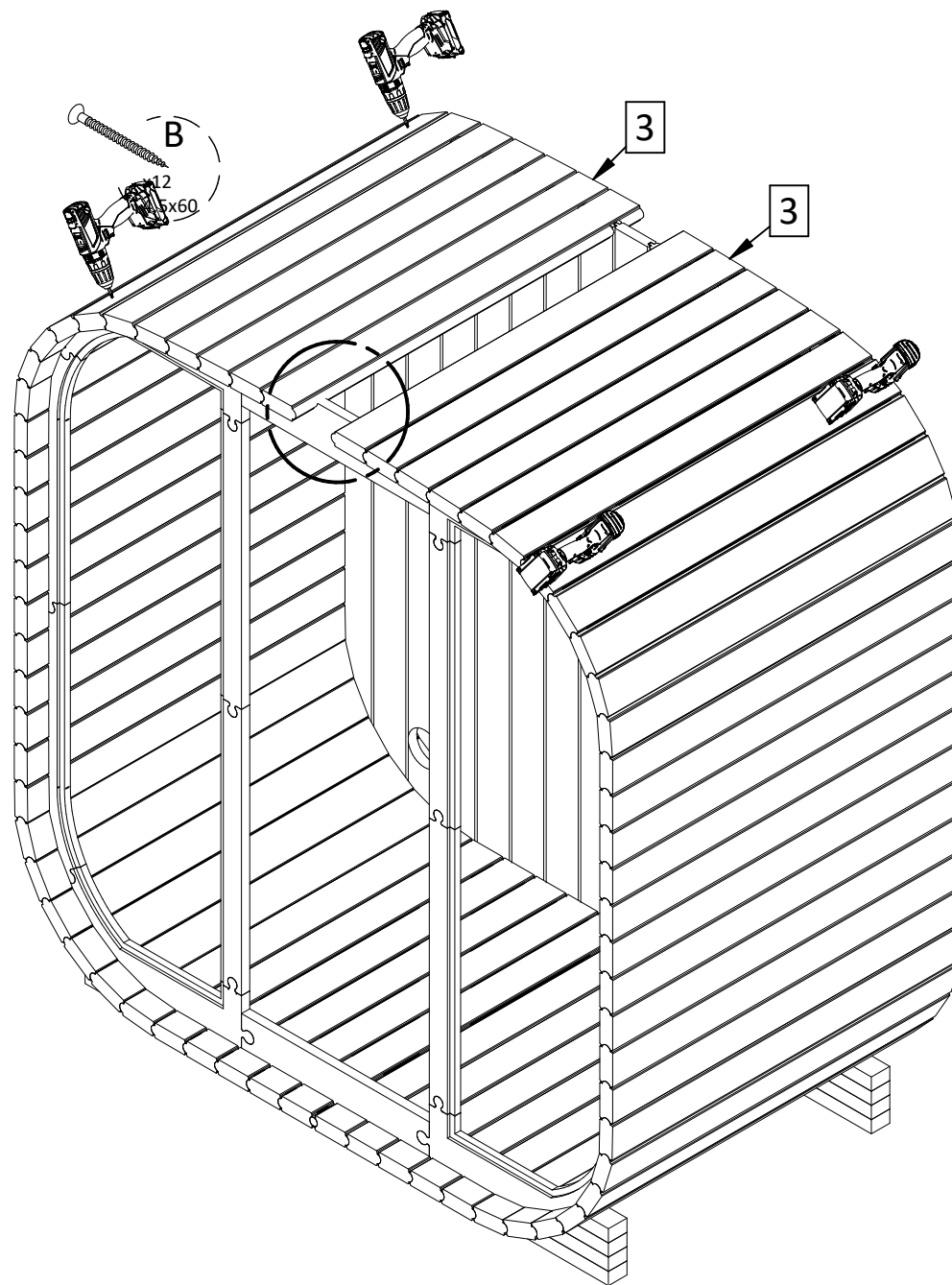
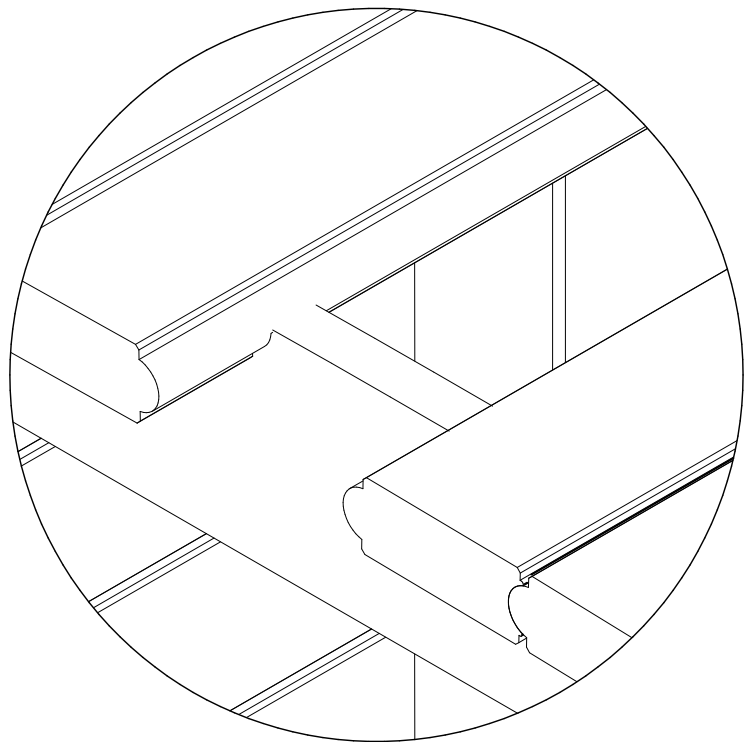

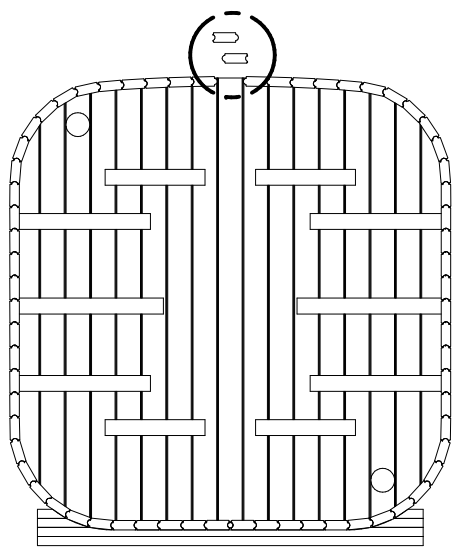
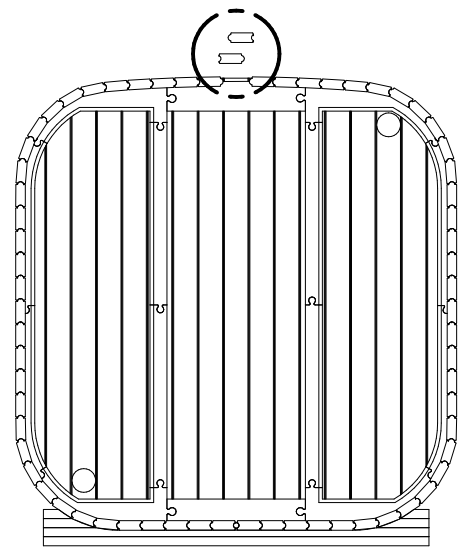
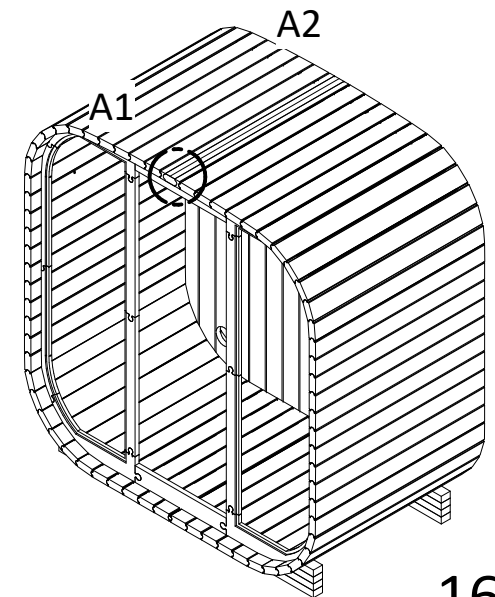
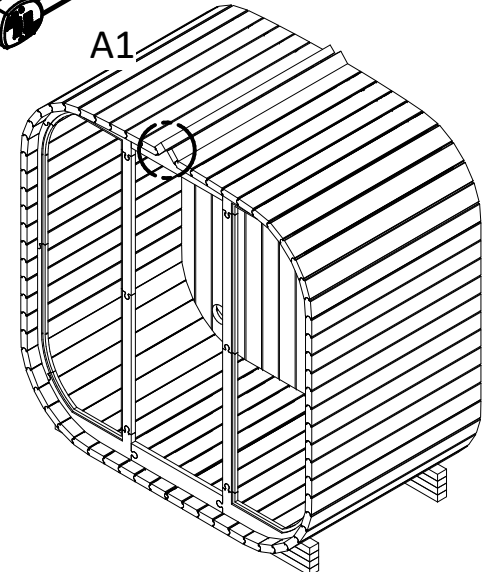
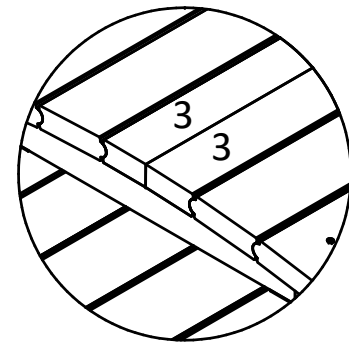
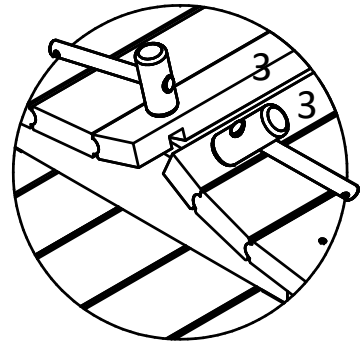
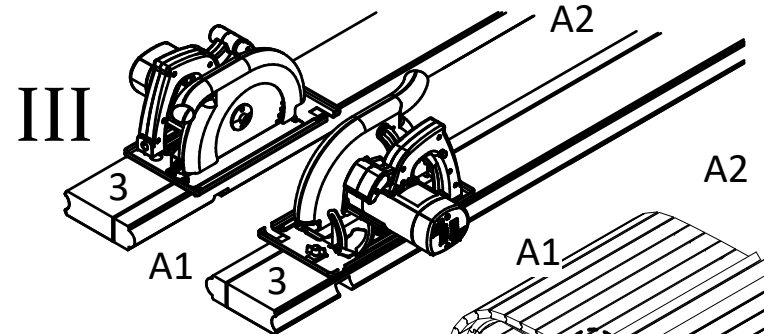
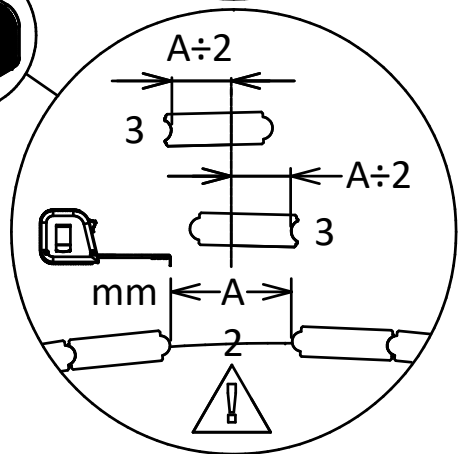
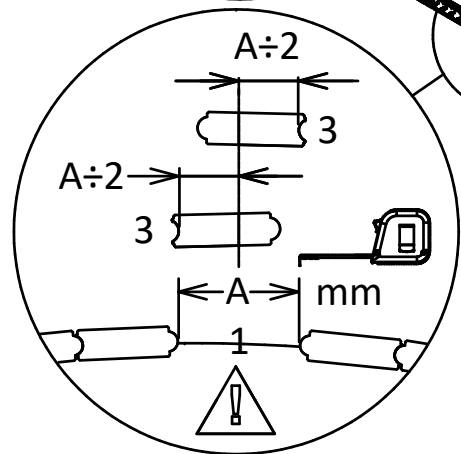
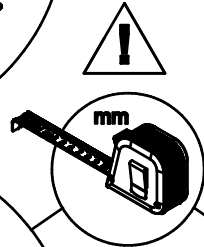
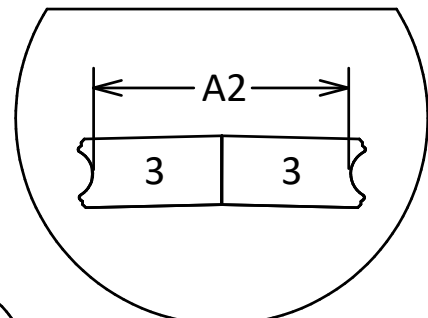
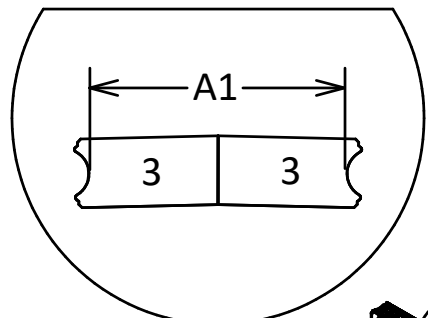

III

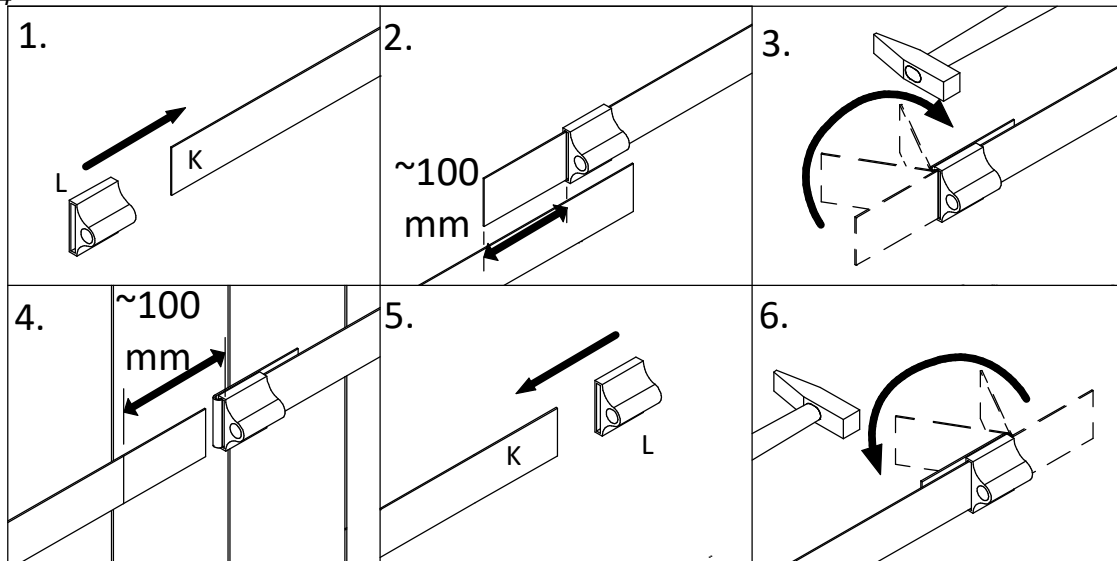

Die Schrauben entfernen.  
Remove the screws.

II

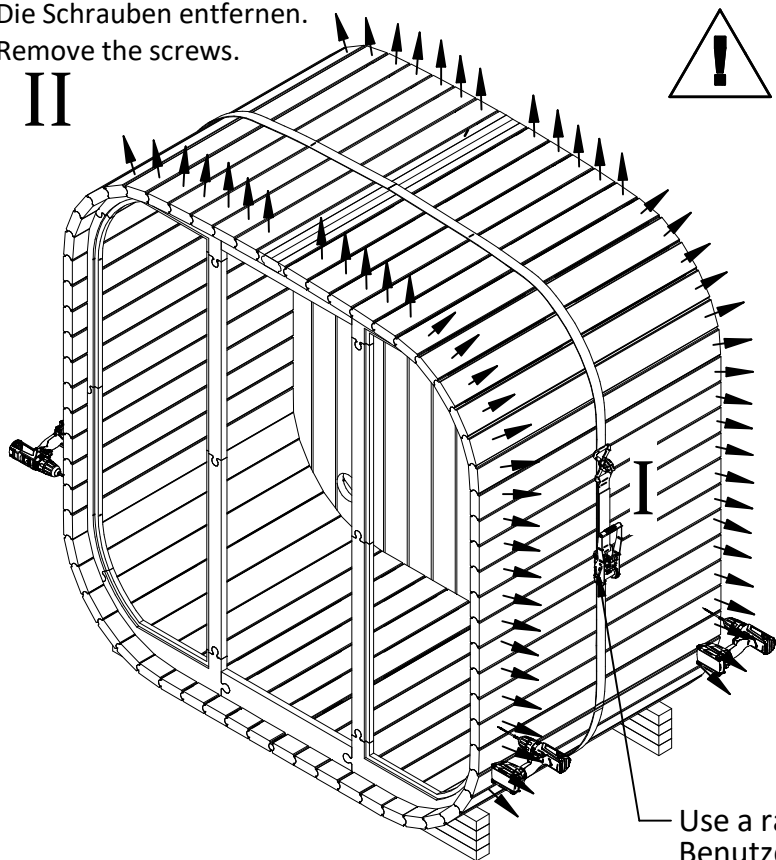

Use a ratchet strap.  
Benutzen sie ein Spannband.

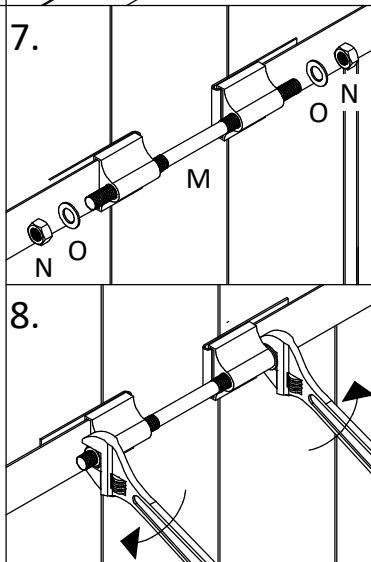

Important! If you have a thermo wood sauna barrel, please do not remove the screws.  
Wichtig! Wenn Sie ein Saunafaß aus Thermoholz haben, entfernen Sie bitte nicht die Schrauben.

IV

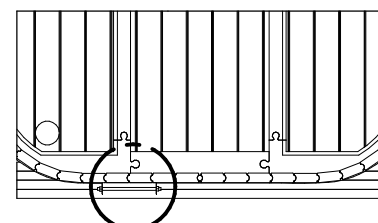

Attention! When assembling and maintaining/retightening the threaded rods, the threaded rods must be oiled with oil (W44 or Würth HPS1400). In this way, damage to the threaded rod can be avoided and it can be clamped more easily.

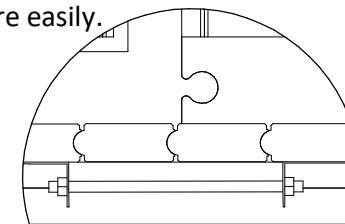

Achtung! Bei der Montage und bei der Pflege/Nachspannen der Gewindestangen, ist die Gewindestange mit Öl (W44 oder Würth HPS1400) zu ölen. So kann eine Beschädigung an der Gewindestange vermieden werden und man kann es leichter spannen.

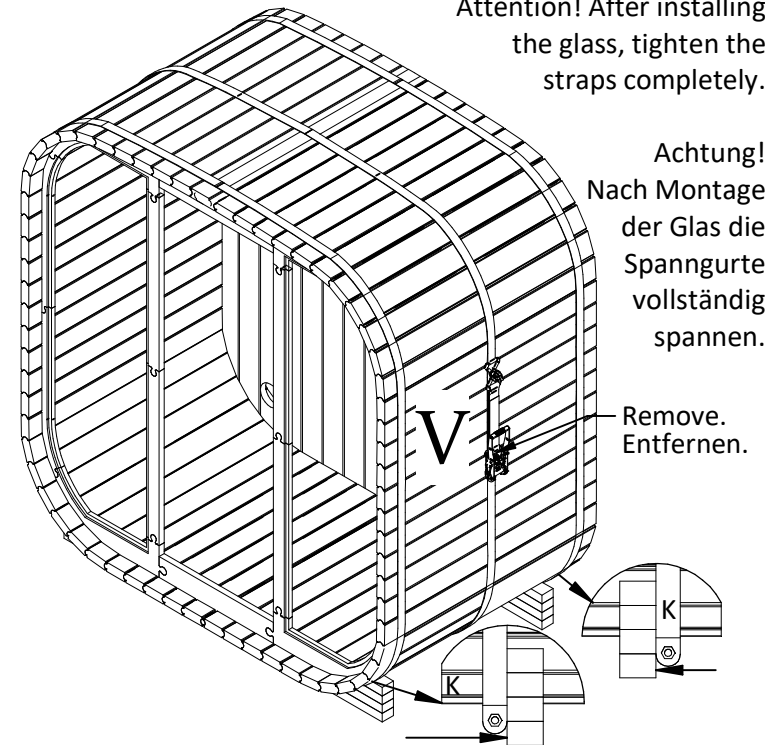

Attention! After installing the glass, tighten the straps completely.

Achtung! Nach Montage der Glas die Spanngurte vollständig spannen.

Remove.  
Entfernen.

Remove all boards from the inside.  
Entfernen Sie alle Bretter von innen.

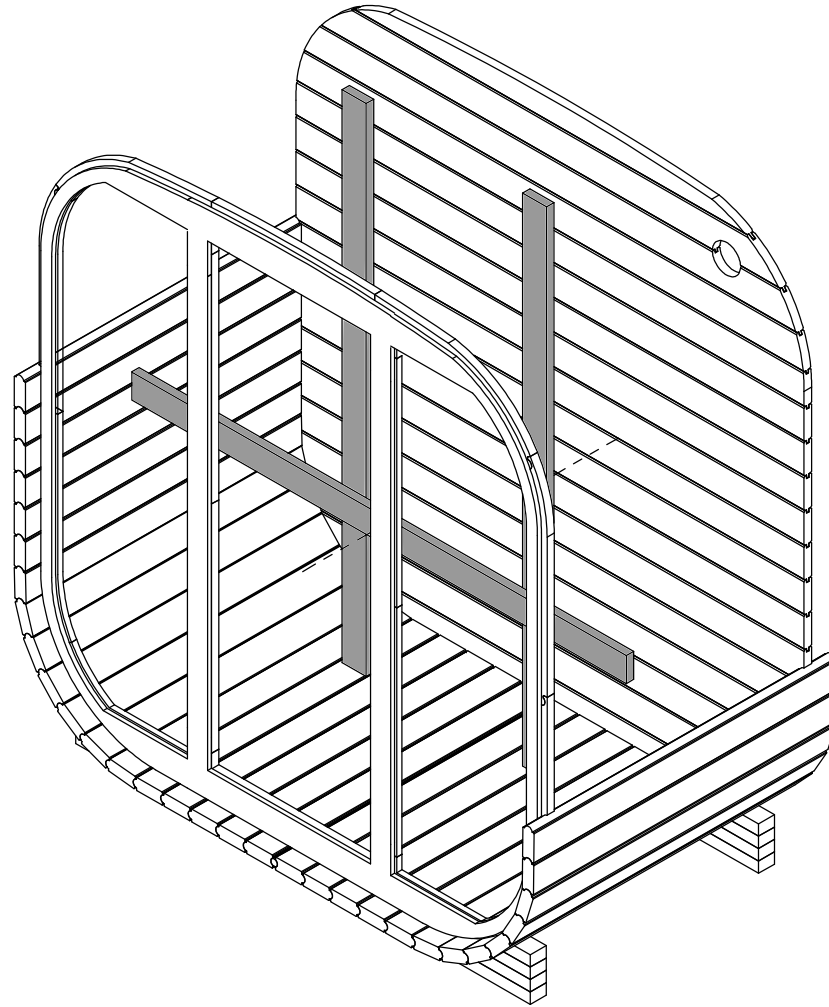

Before processing the screws.

Pre-drill the holes  
with a 4 mm drill bit.

Bitte bohren Sie  
die  $\phi 4$ mm Löcher vor  
dem Schrauben vor

Use a spirit level  
Benutzen Sie eine  
Wasserwaage

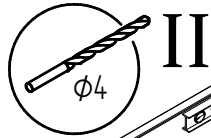

II

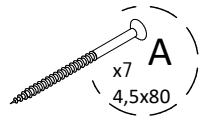
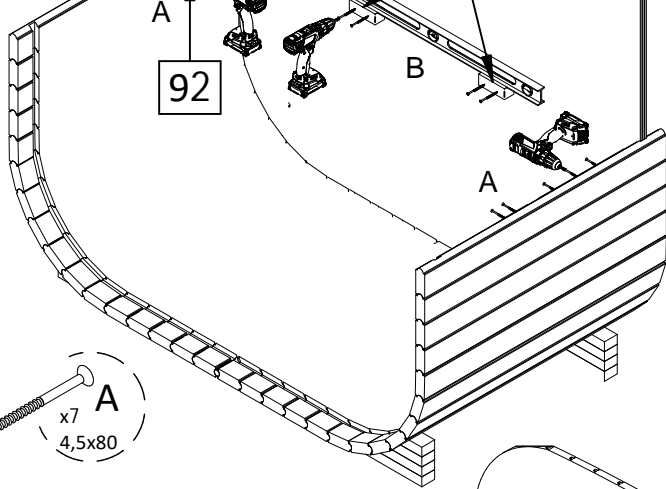

A  
x7  
4,5x80

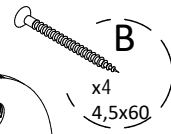

B  
x4  
4,5x60

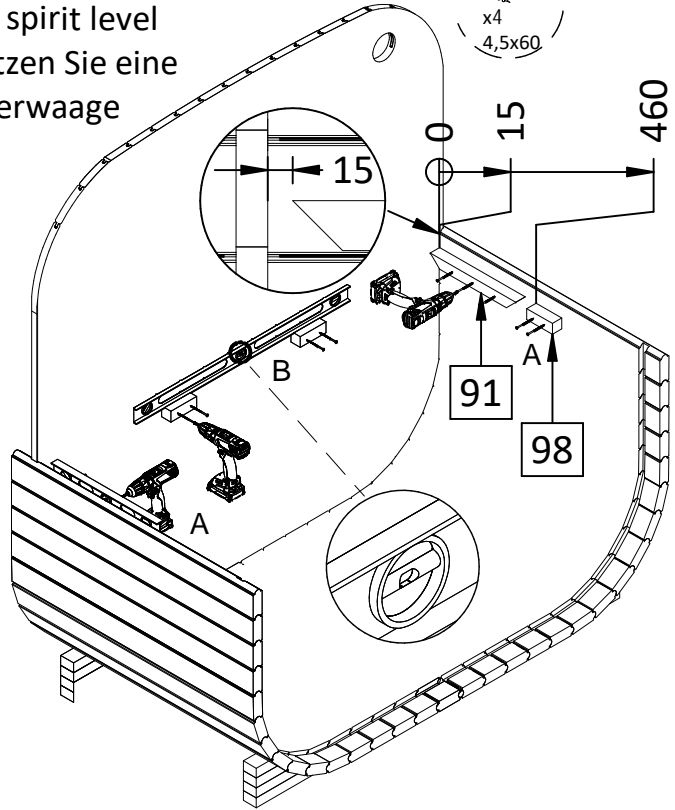

I

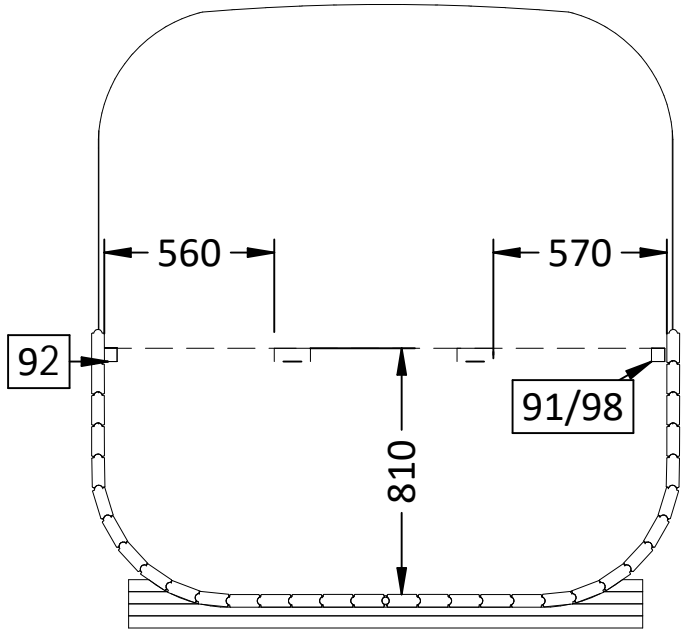

III

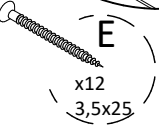
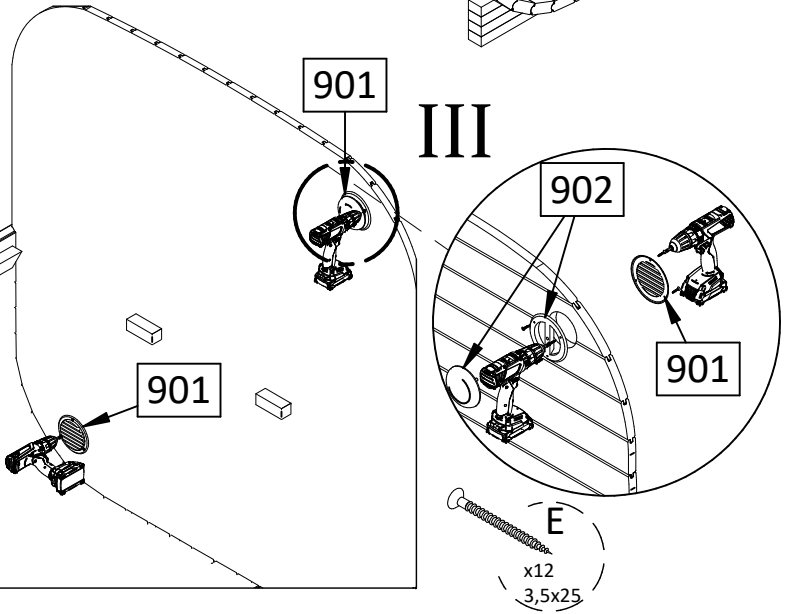

E  
x12  
3,5x25

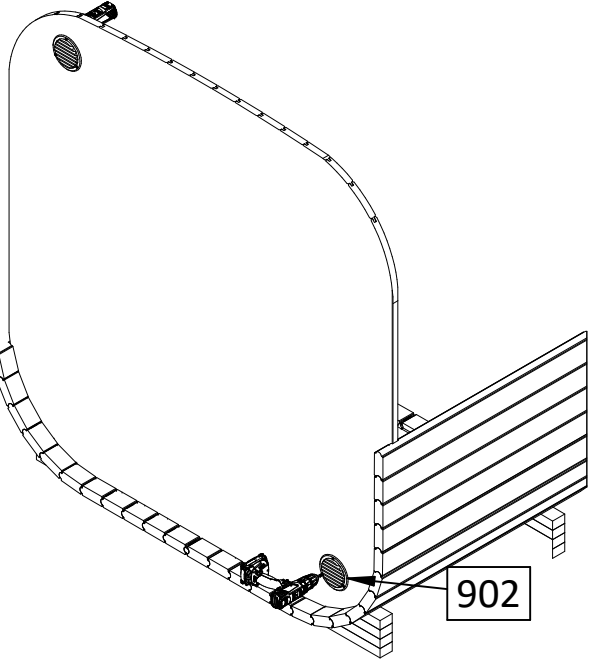

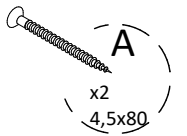
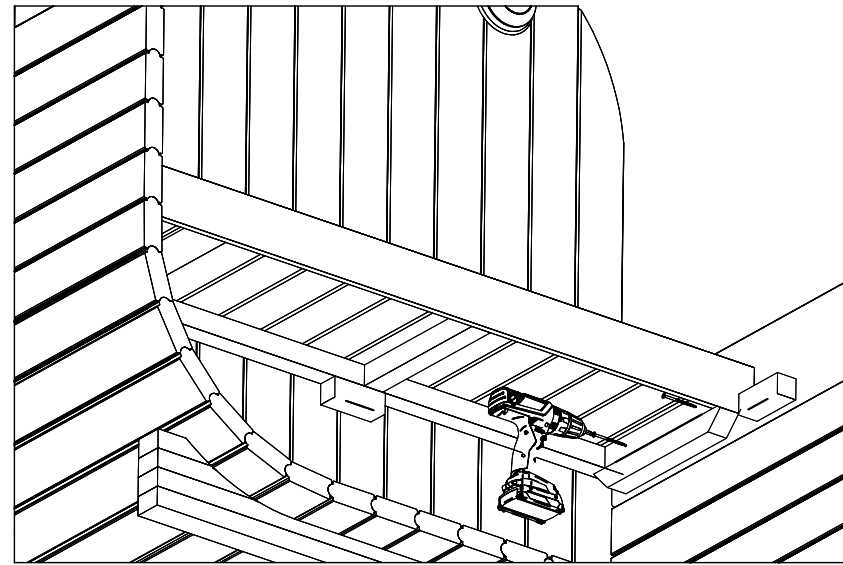
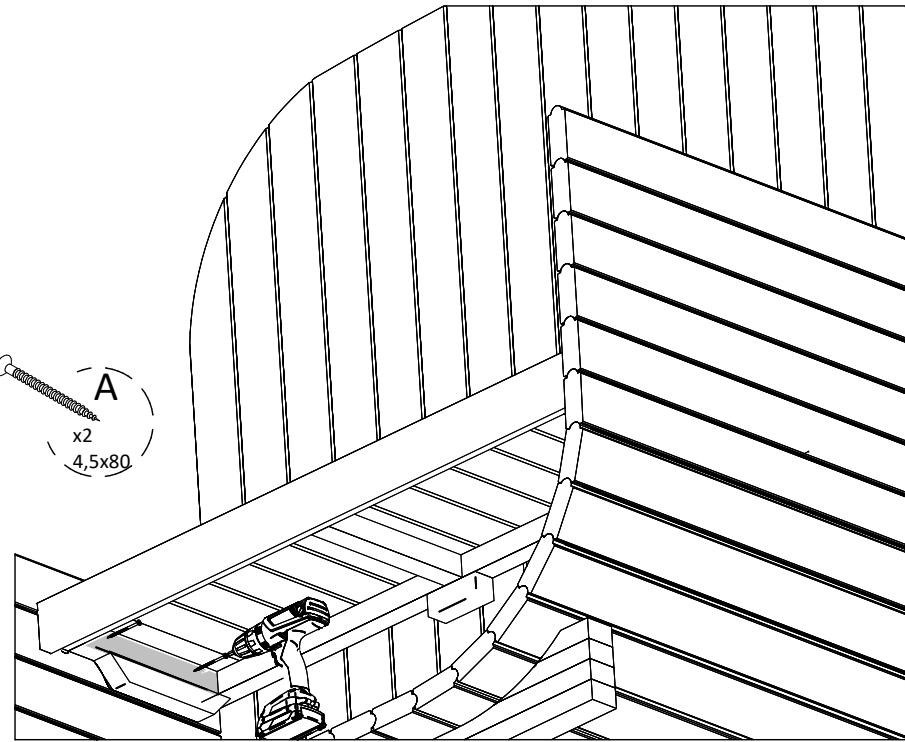
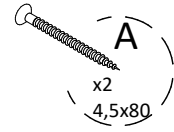
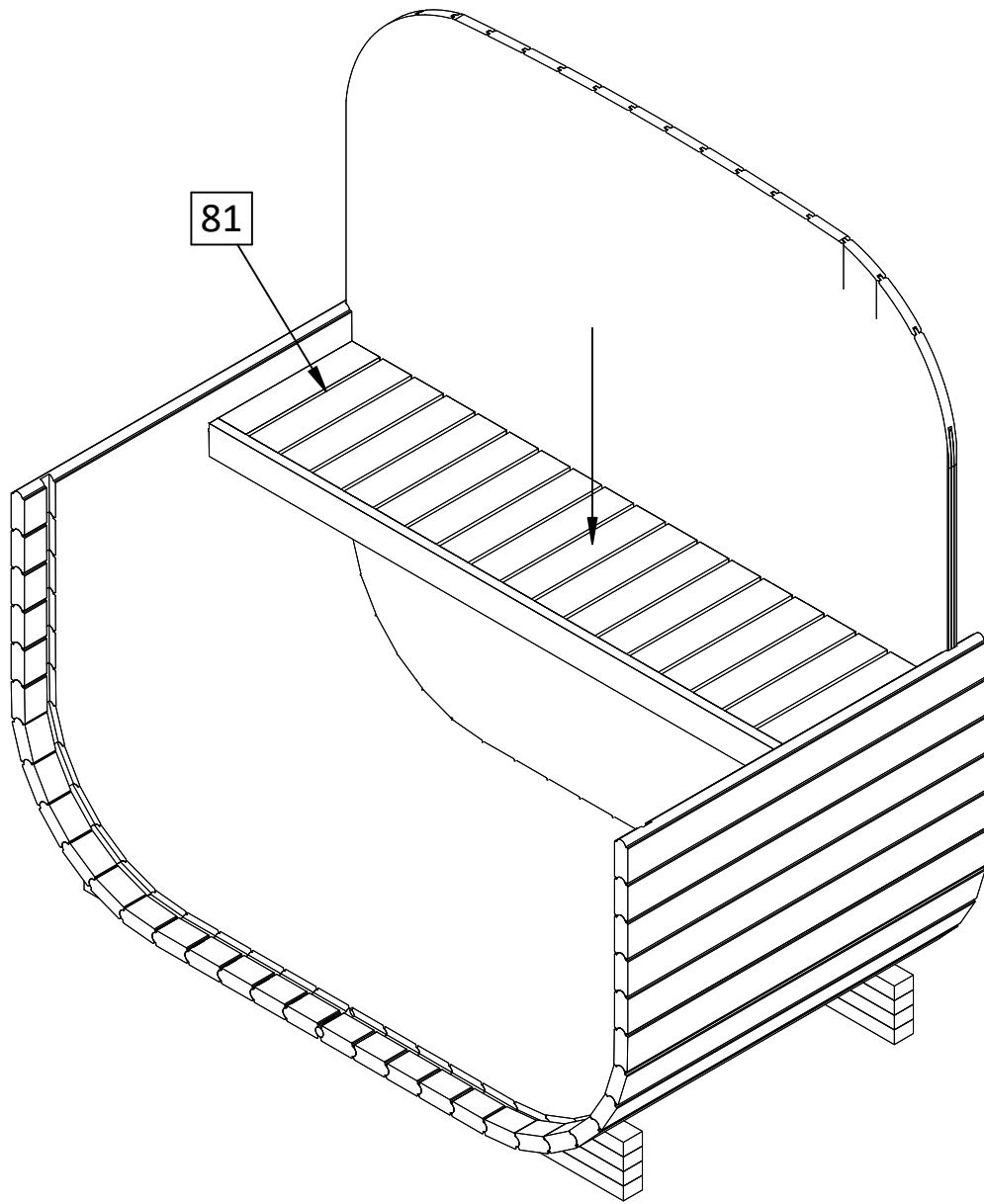

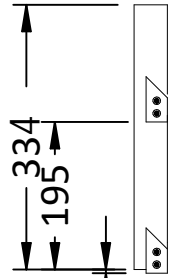

Before processing the screws.  
Pre-drill the holes  
with a 4 mm drill bit.

Bitte bohren Sie  
die  $\phi 4$ mm Löcher vor  
dem Schrauben vor

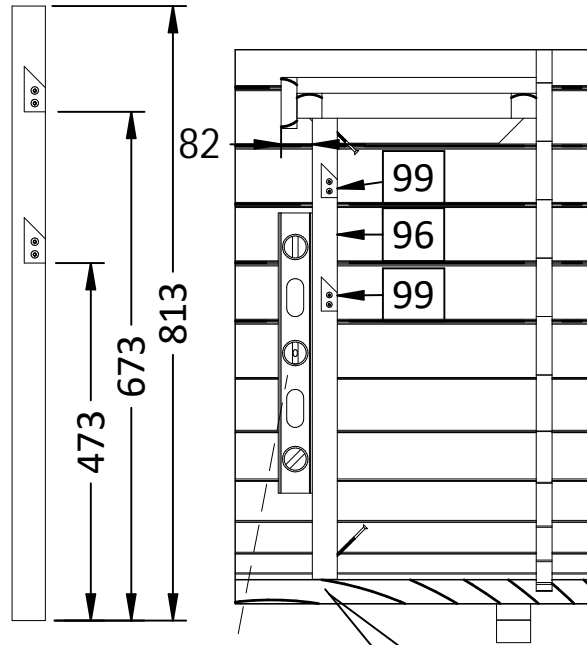
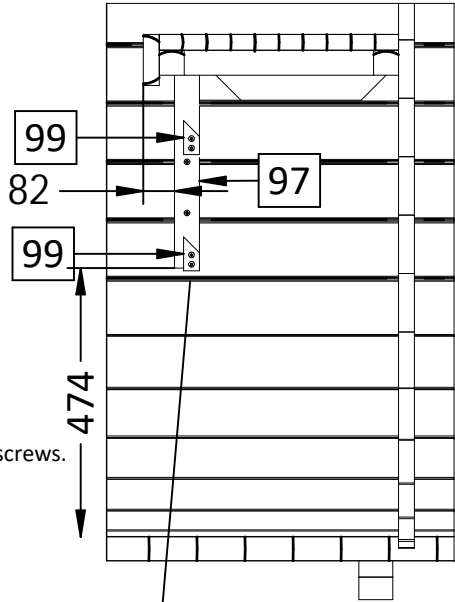

2x

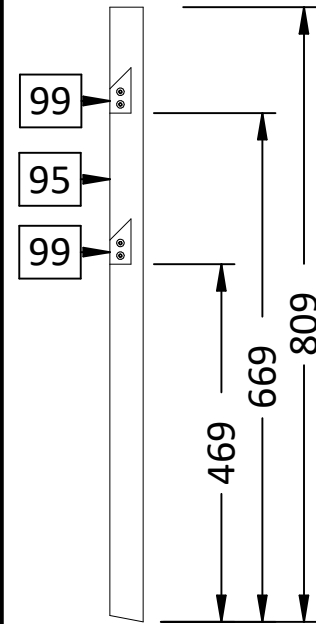

Next page

Nächste Seite

Before processing the screws.  
Pre-drill the holes  
with a 4 mm drill bit.

Bitte bohren Sie  
die  $\phi 4$ mm Löcher vor  
dem Schrauben vor

Use a spirit level  
Benutzen Sie eine  
Wasserwaage

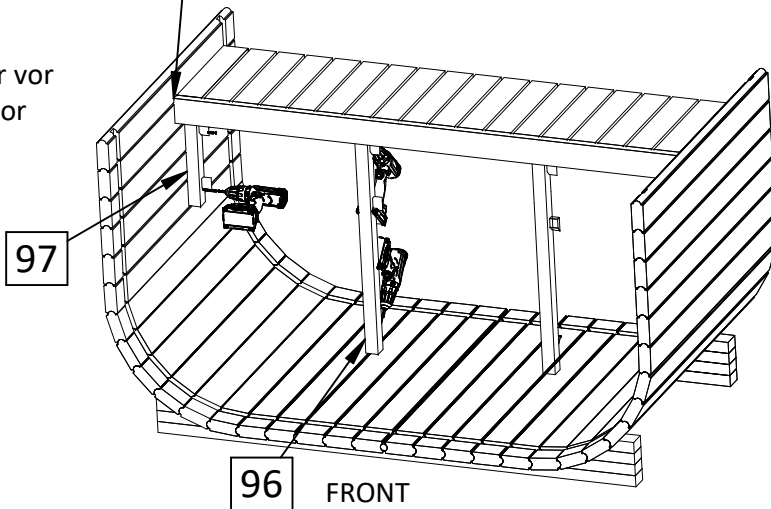
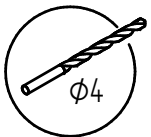

96 FRONT

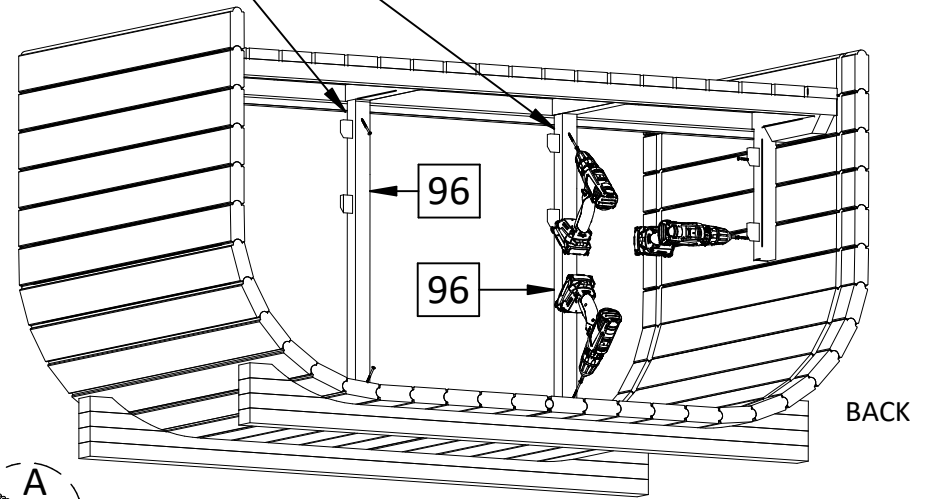

BACK

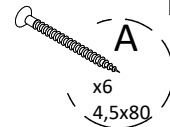

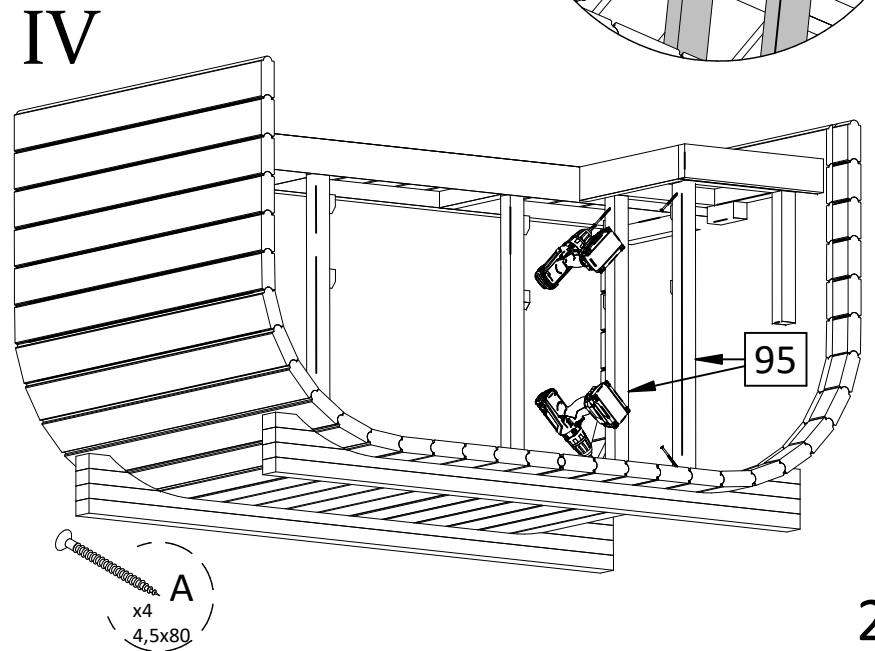
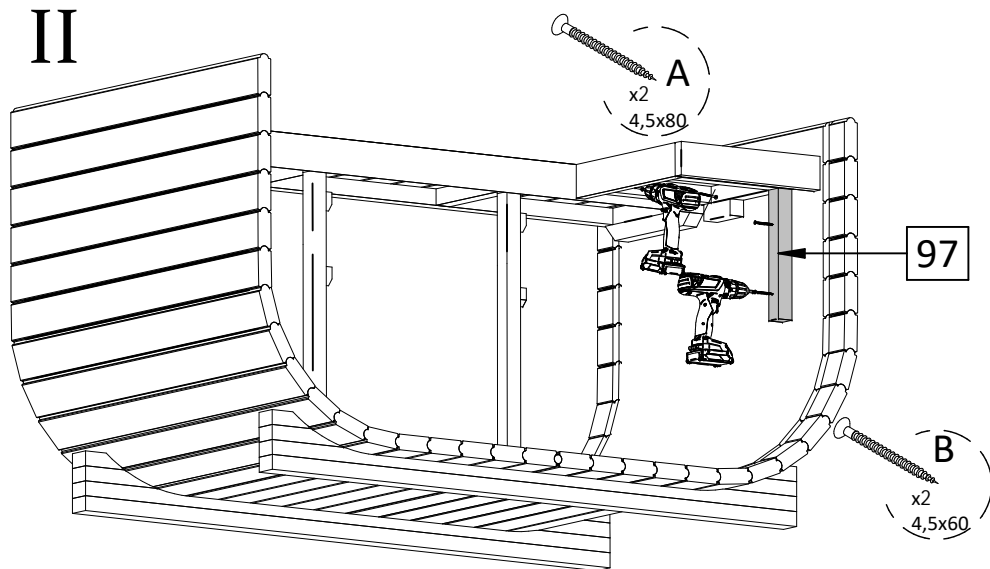
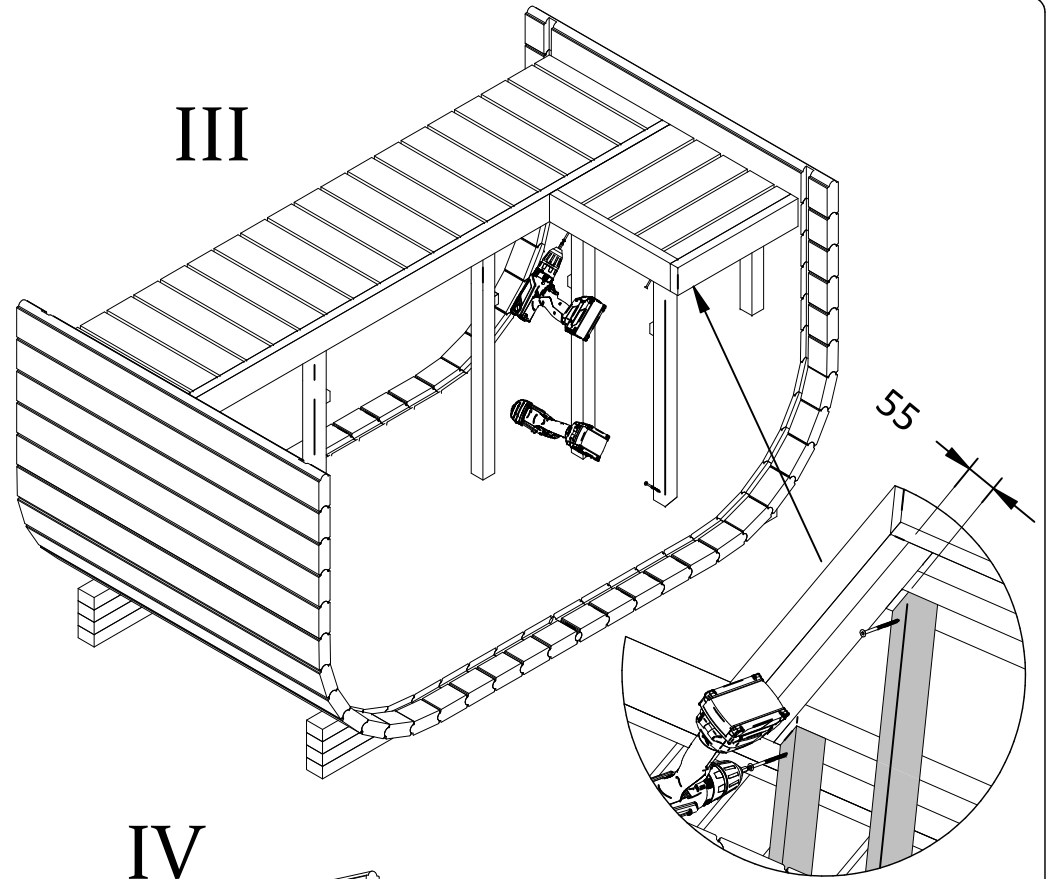
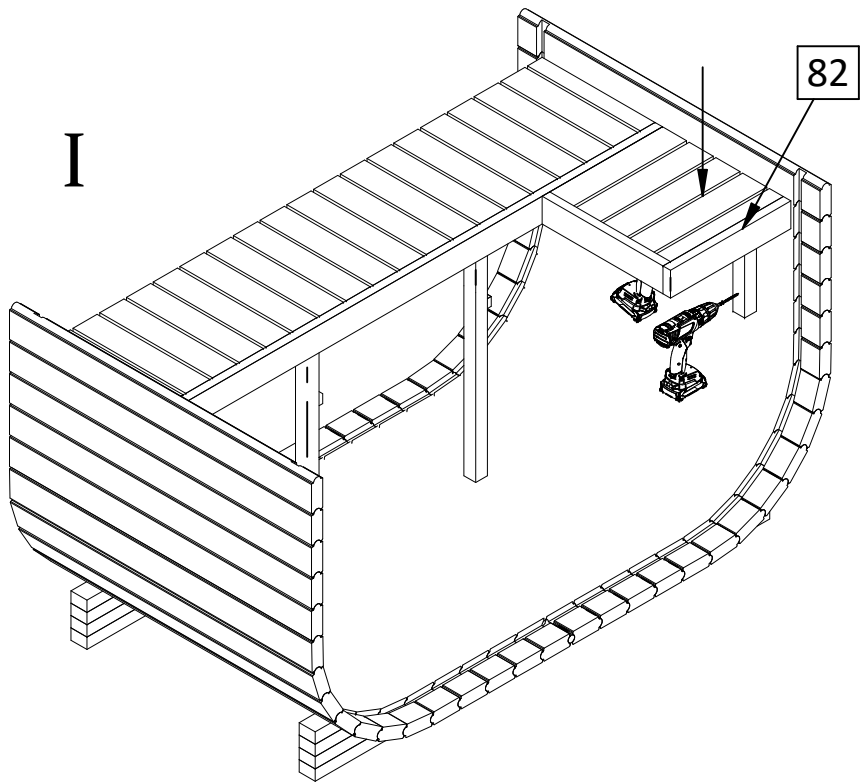

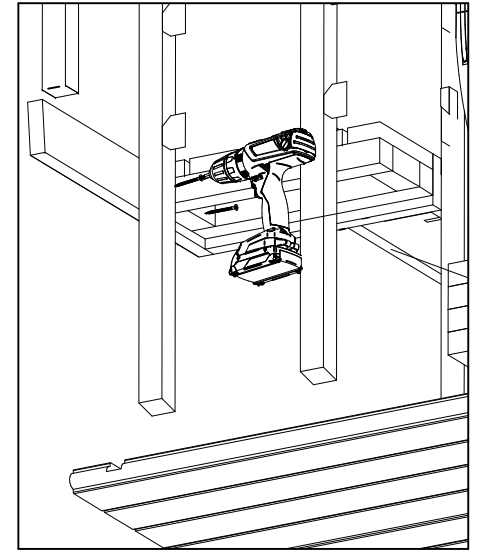
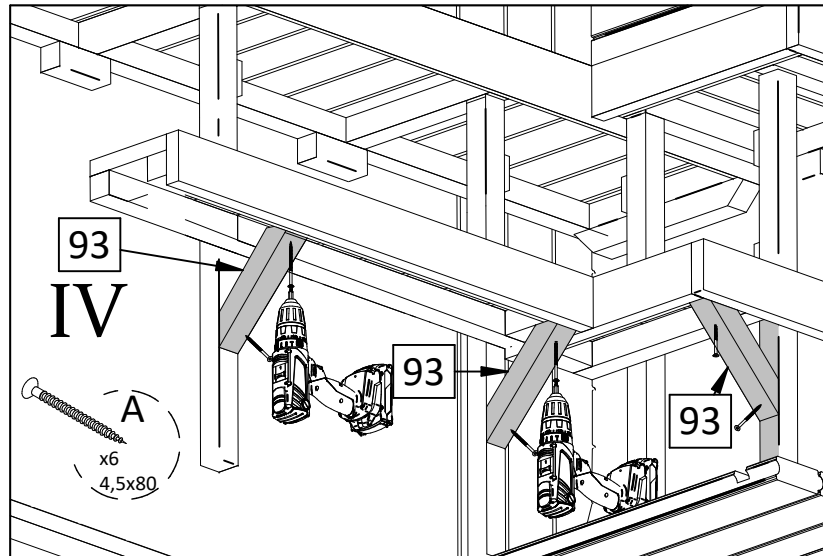
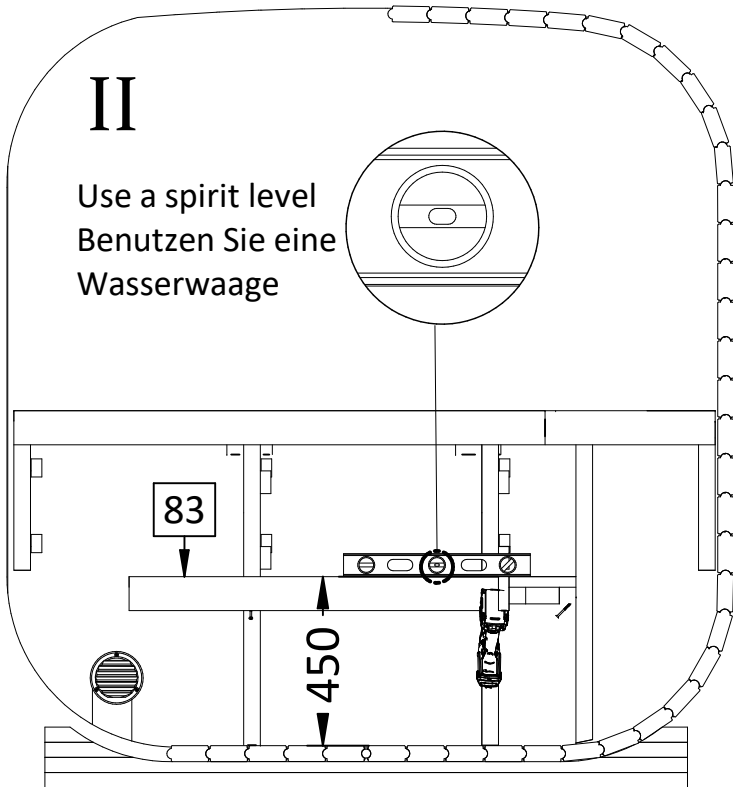
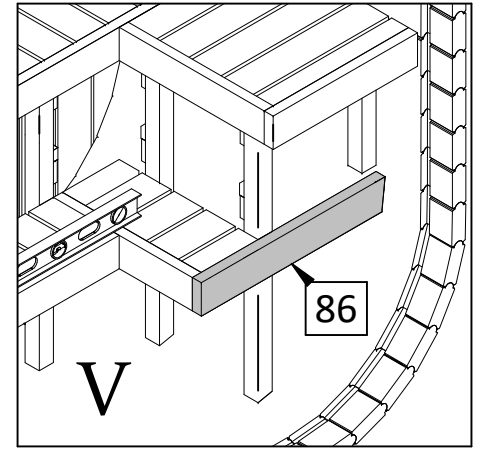
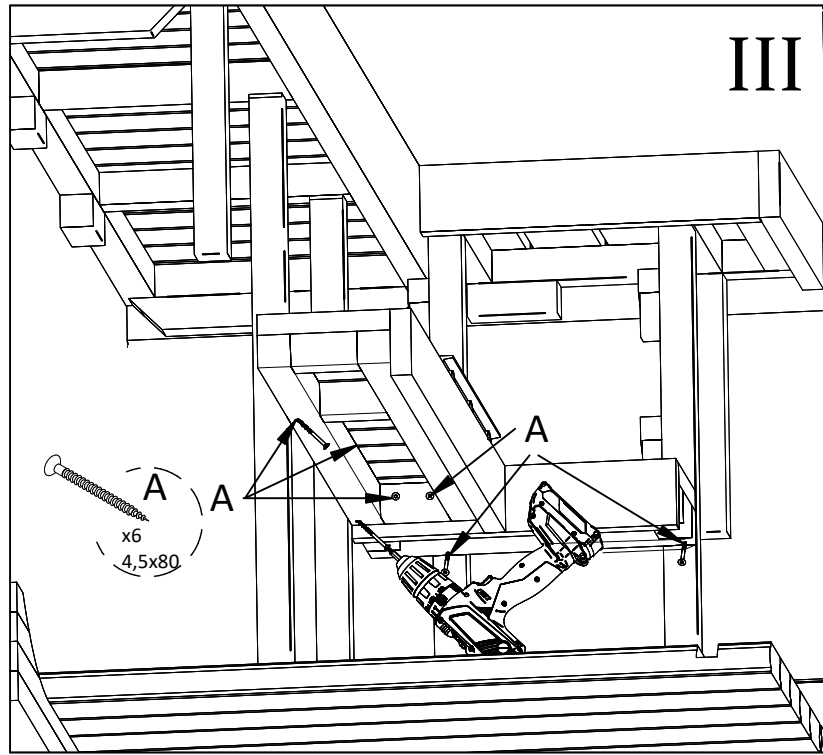
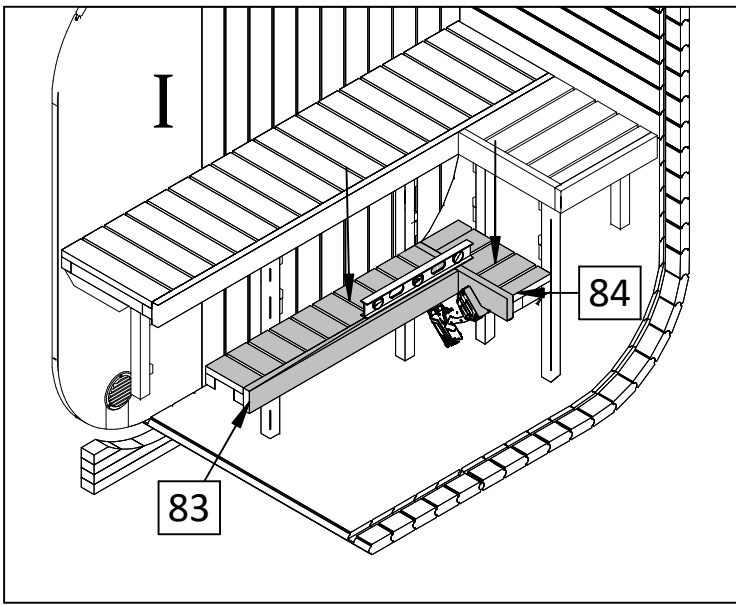

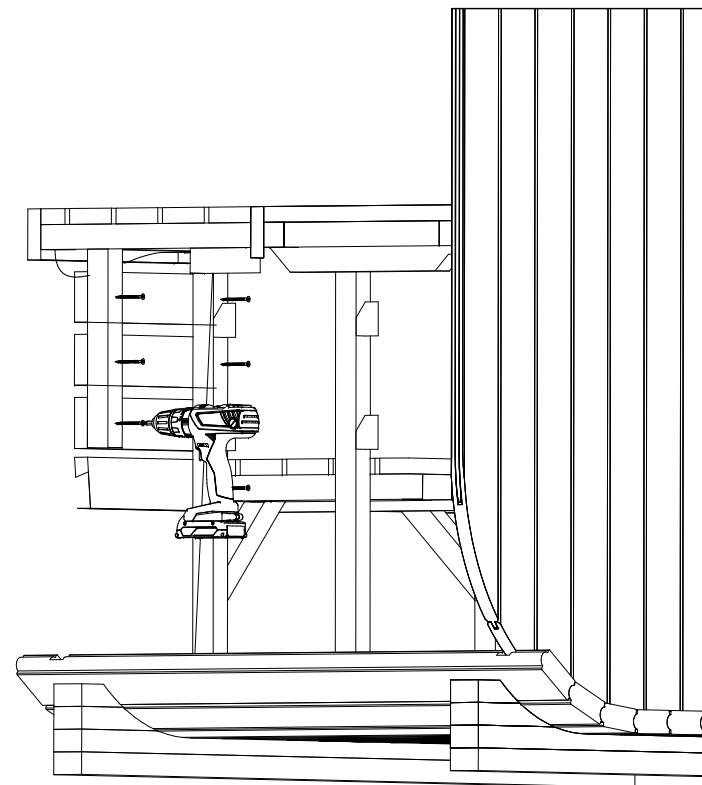
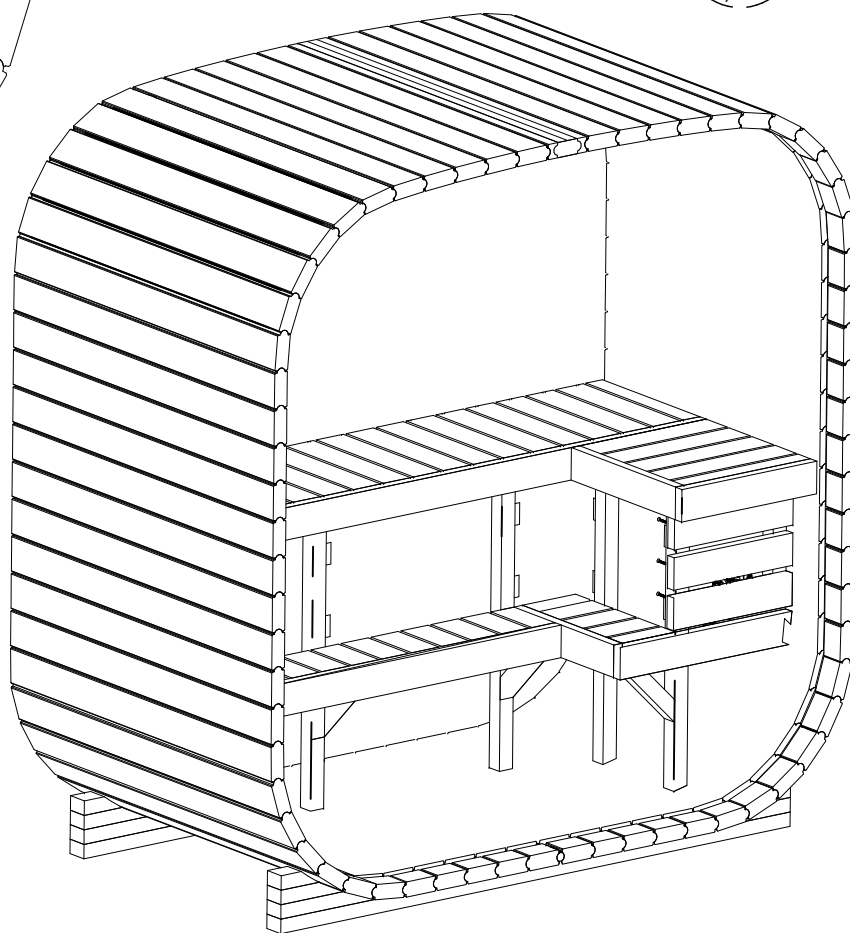
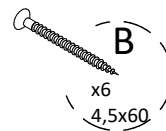
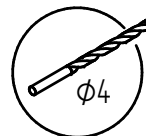
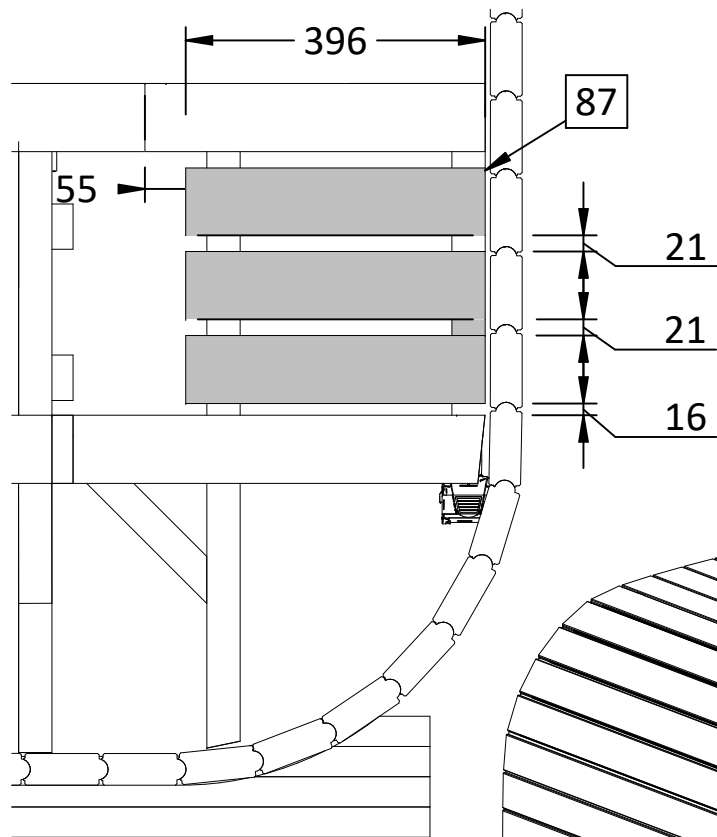

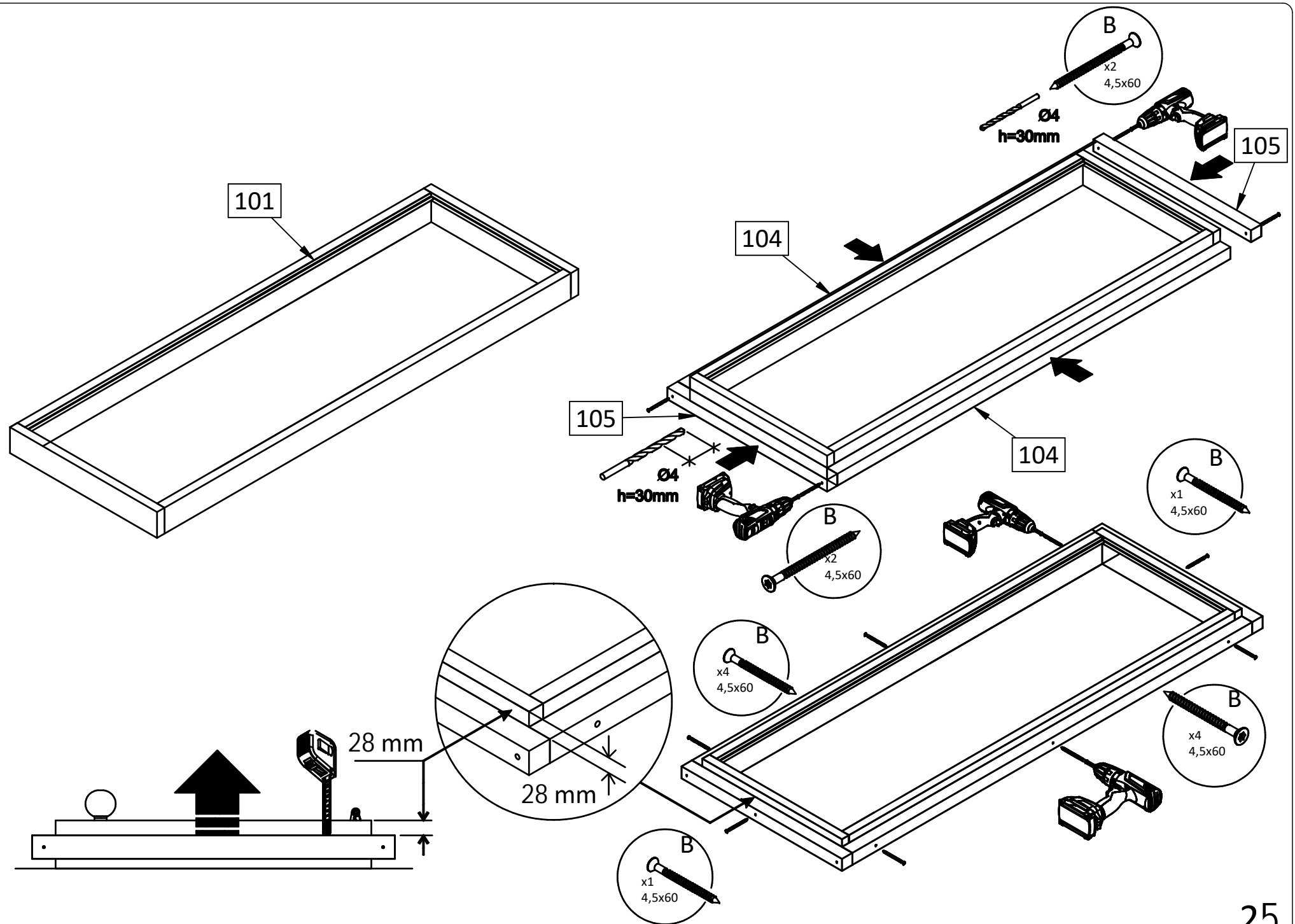

Before processing the screws.

Pre-drill the holes  
with a  $\phi 3$ mm drill bit.

Bitte bohren Sie  
die  $\phi 3$ mm Löcher vor  
dem Schrauben vor

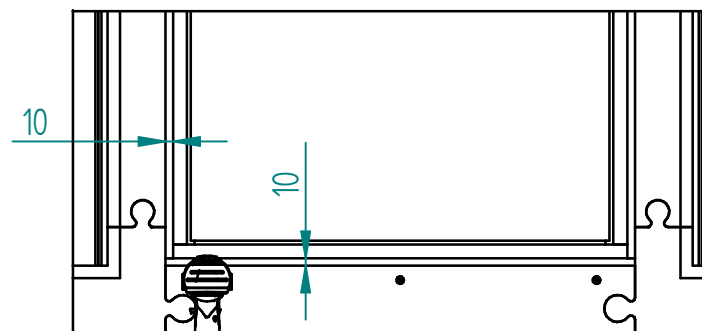
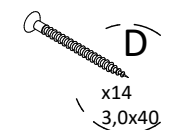
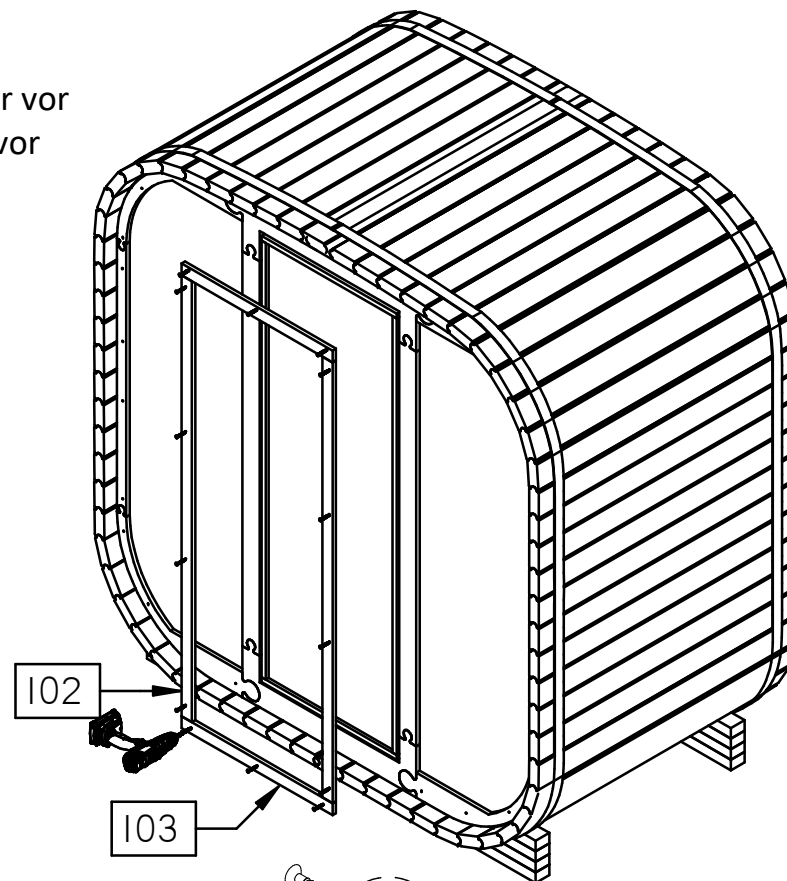
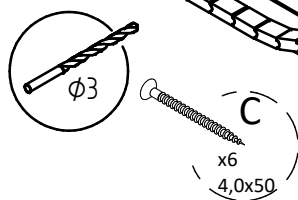

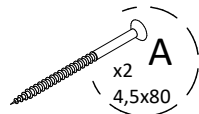
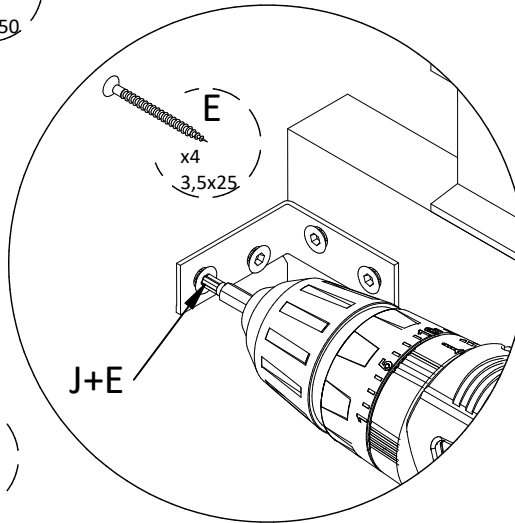
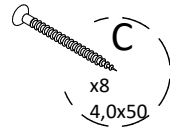
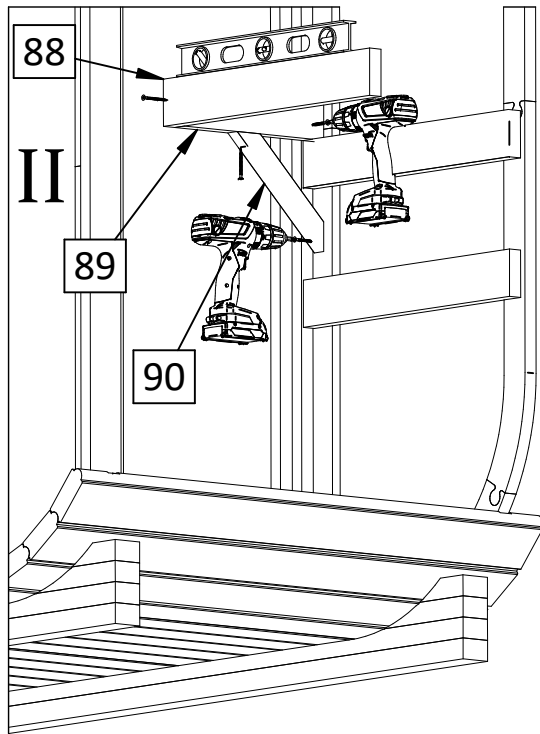
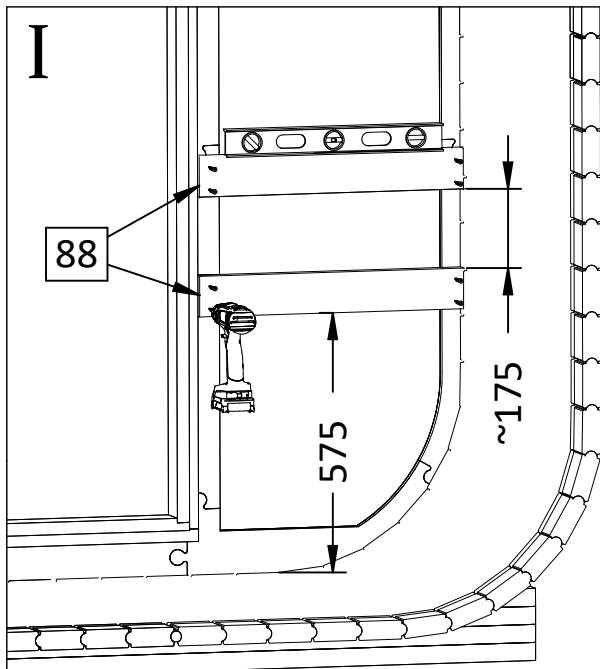

Use a spirit level  
Benutzen Sie eine  
Wasserwaage

Before processing the screws.  
Pre-drill the holes  
with a 4 mm drill bit.

Bitte bohren Sie  
die  $\phi 4$ mm Löcher vor  
dem Schrauben vor

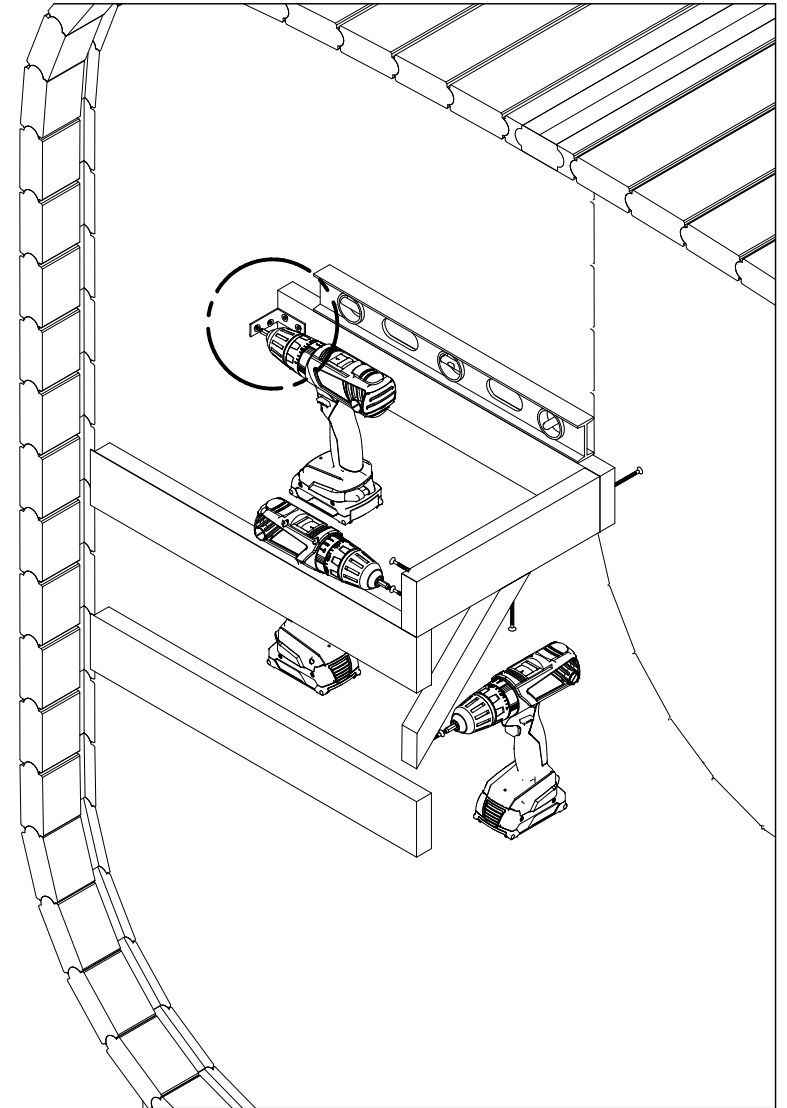
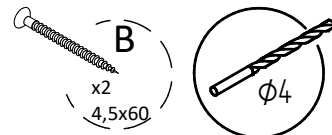

III

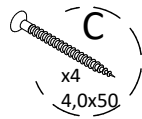
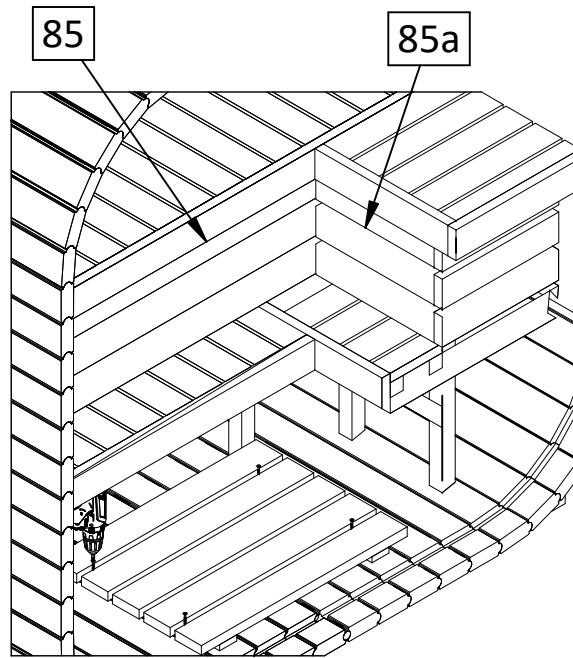
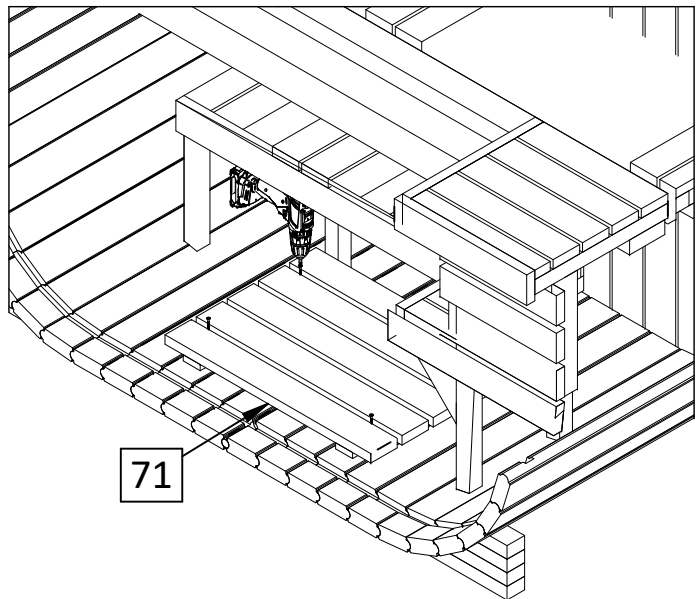
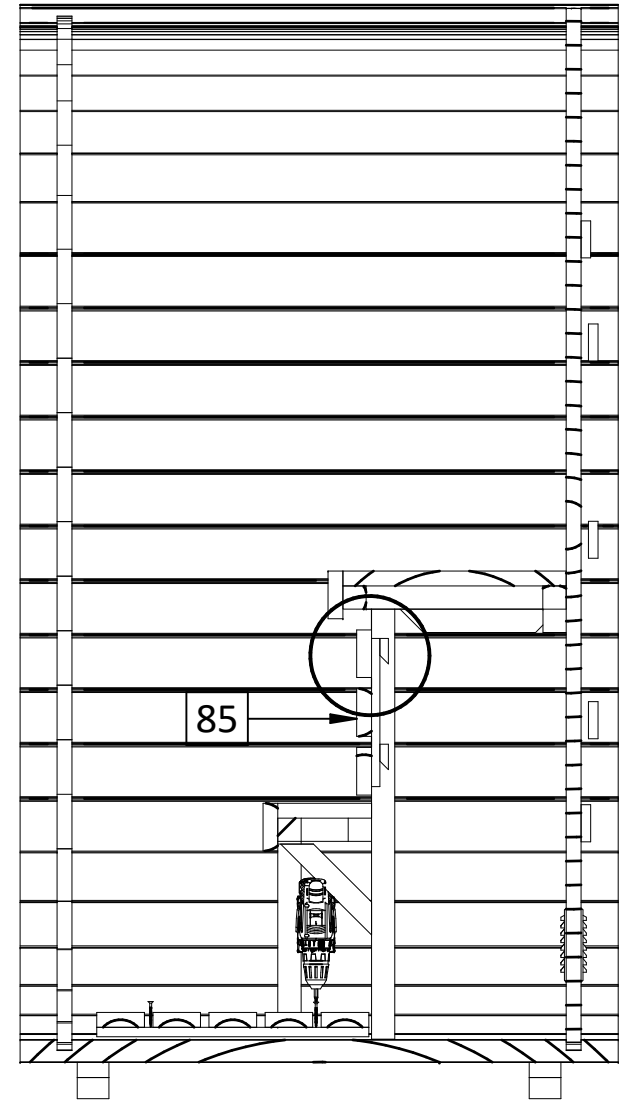
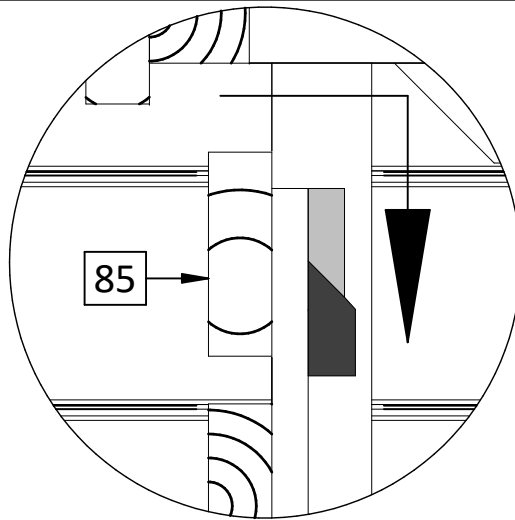

NB! Check also shingles installation manual inside the package.

# OPTIONAL

08.08.25

NB! Bitte bei Dachschindeln Montage beachten die Montageanleitung, welche in Dachschindeln Pakete liegt.

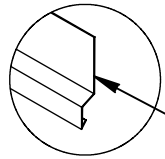
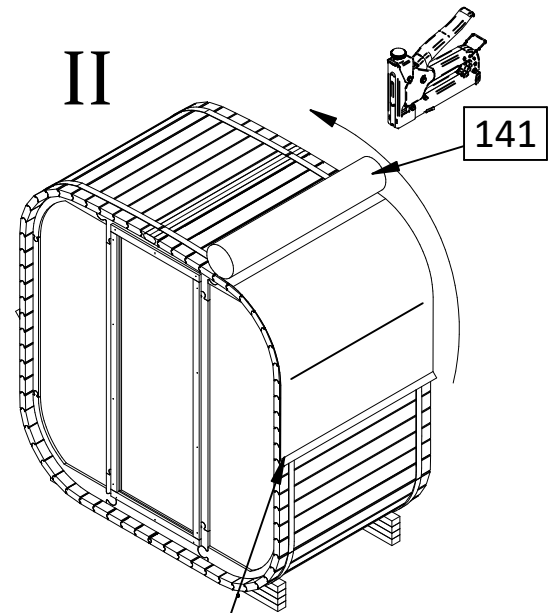
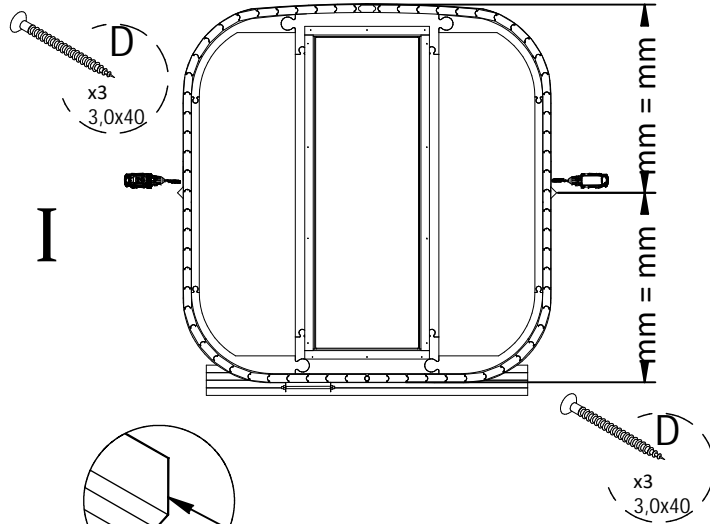
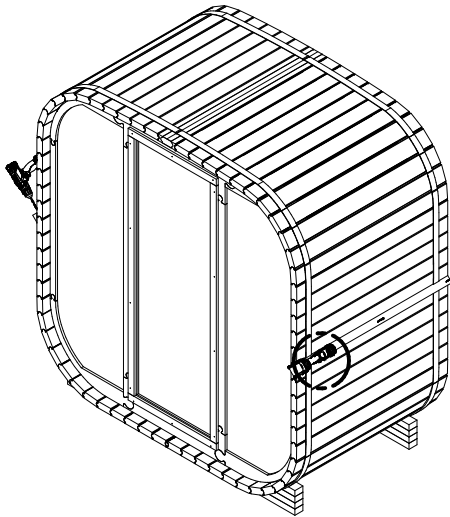

4 Please cut the clapboards to size and use the other half on the other side.

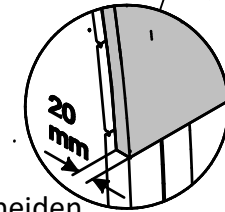

Bitte die Schindeln auf die richtige Länge schneiden und mit dem Reststück die neue Reihe anfangen.

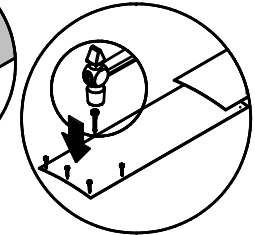

### III

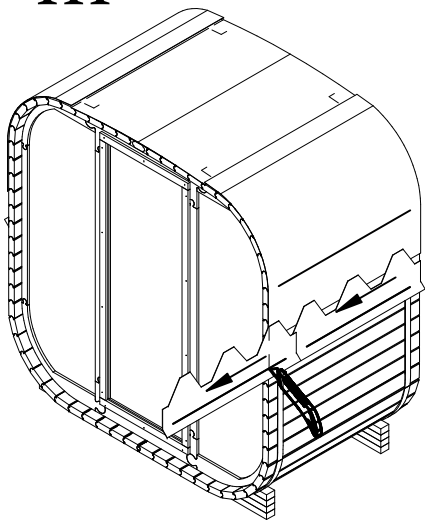

### IV

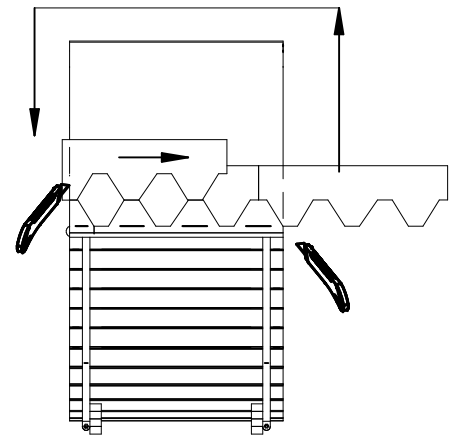
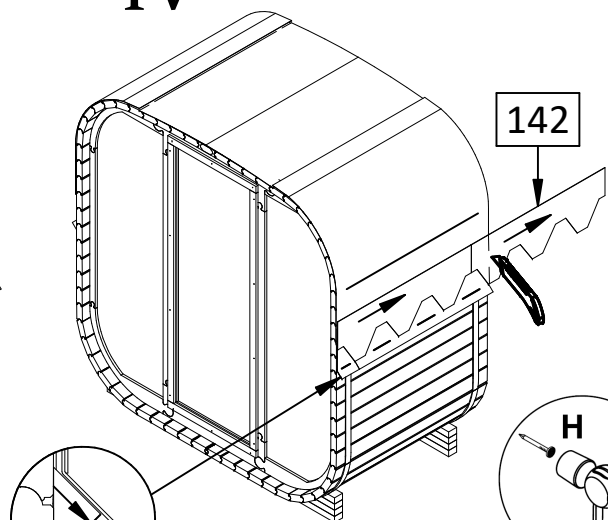

### V

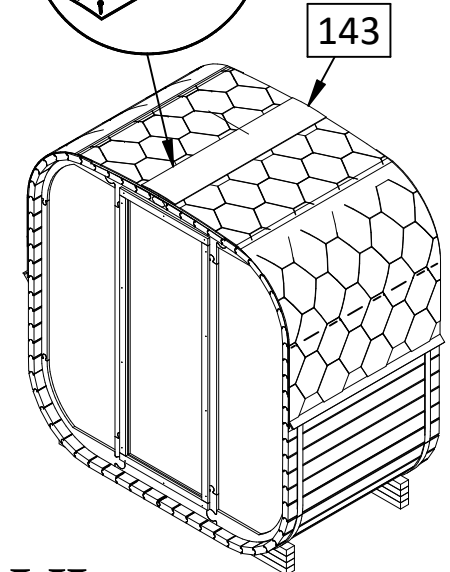

### VI

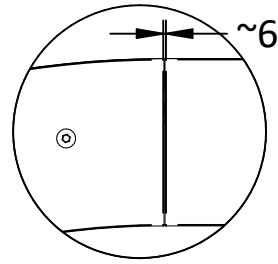

Attention! Leave a gap of 6 mm.

Achtung! Einen Zwischenraum von 6 mm lassen.

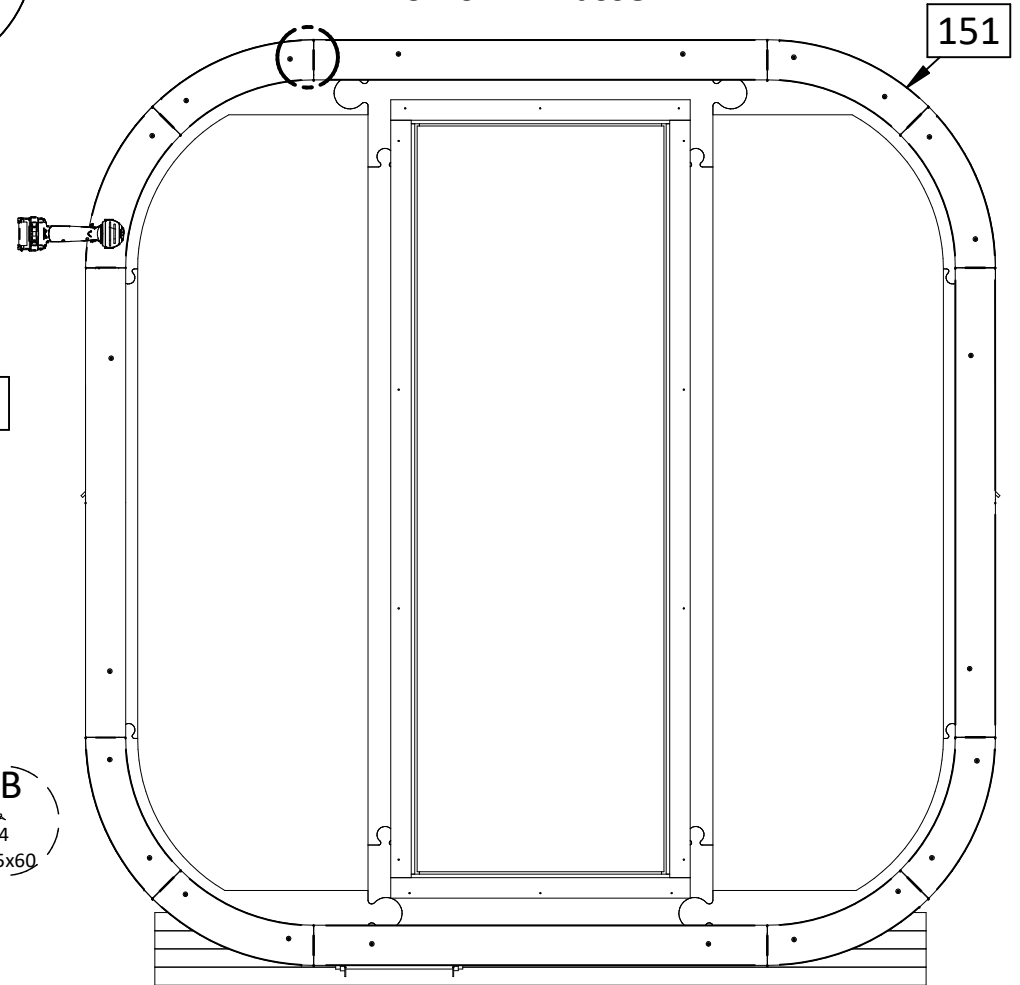
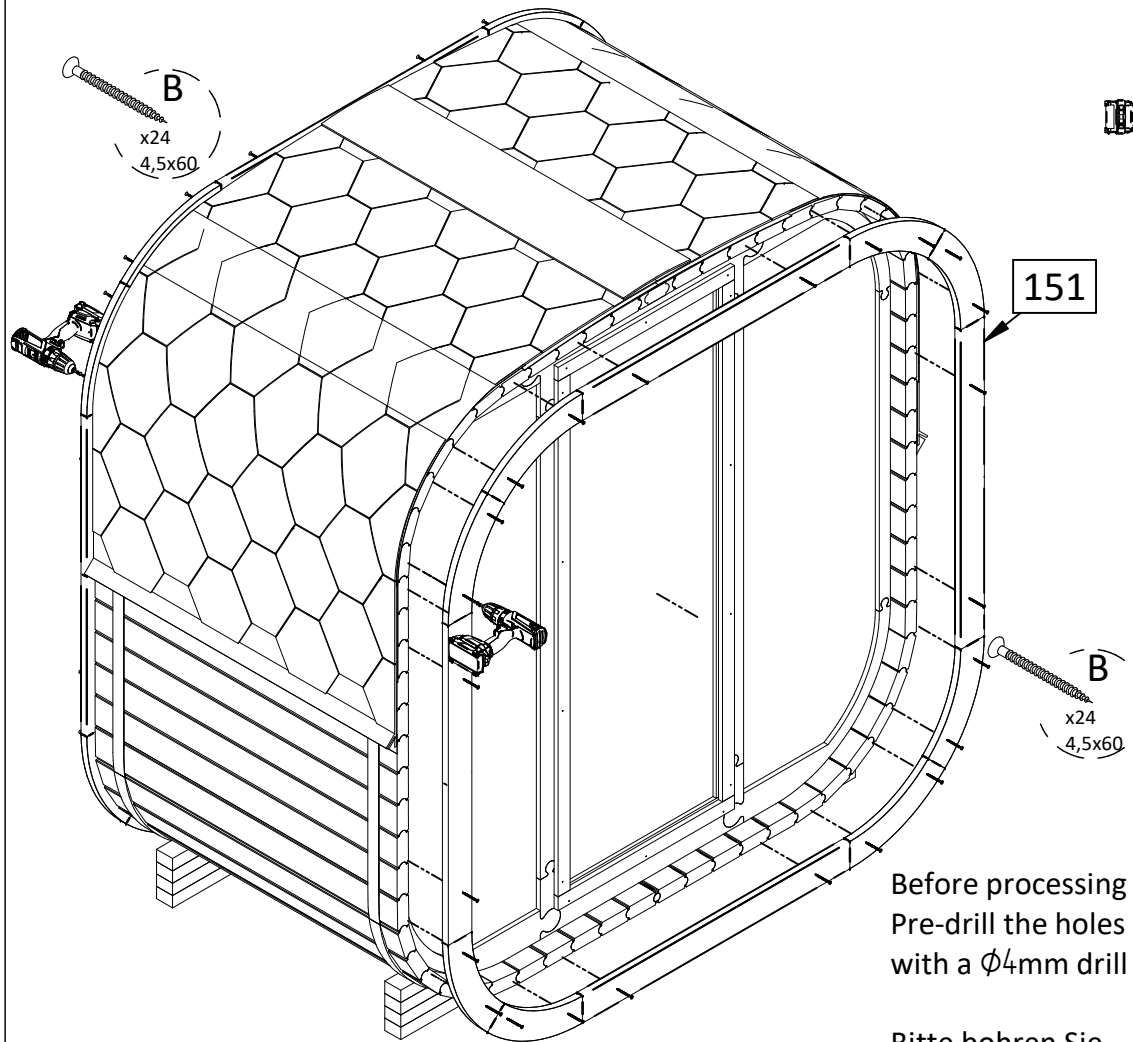

Before processing the screws.  
Pre-drill the holes  
with a  $\phi 4$ mm drill bit.

Bitte bohren Sie  
die  $\phi 4$ mm Löcher vor  
dem Schrauben vor

Falls nötig, schneiden Sie die Details in die passende Größe.  
If necessary, cut the details to the appropriate size