

LUMI

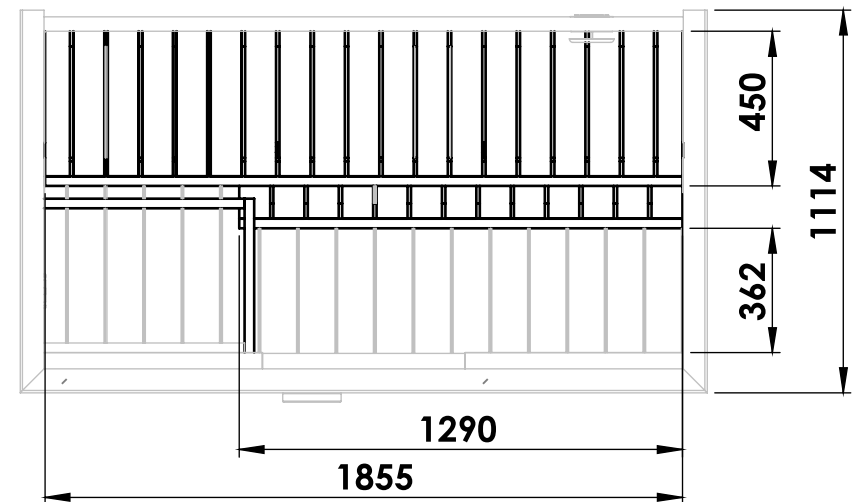

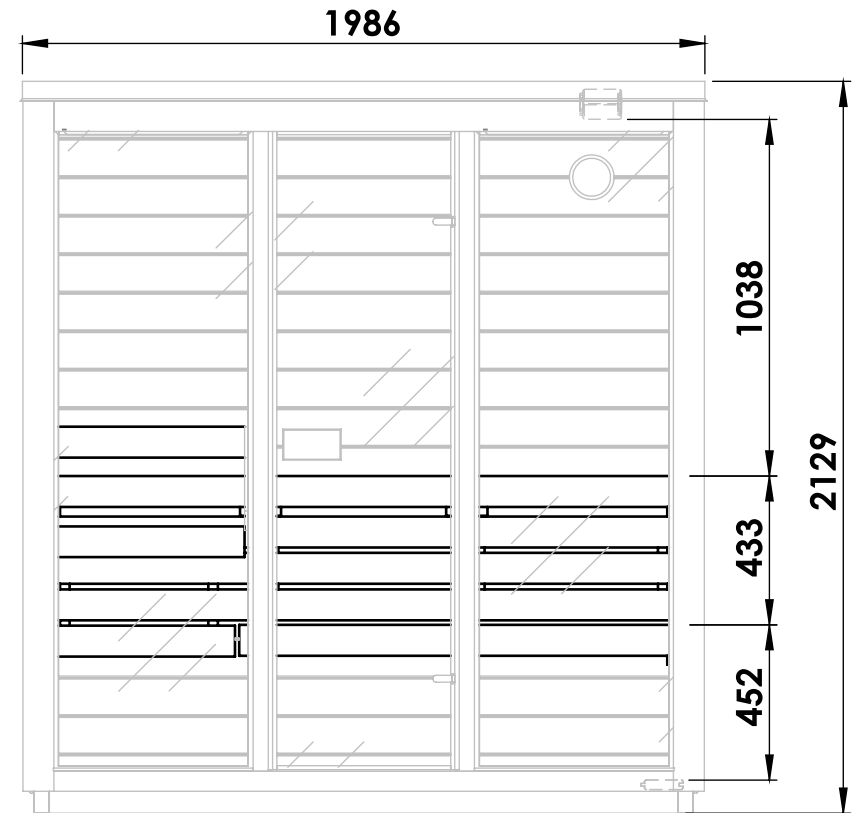

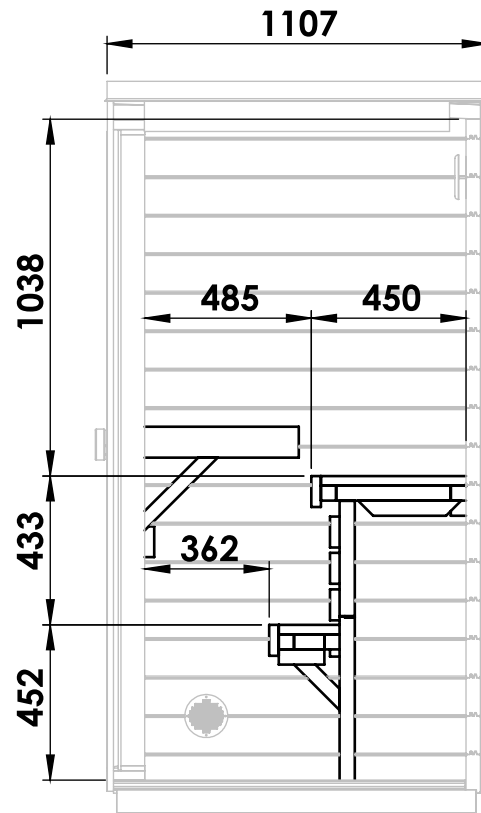
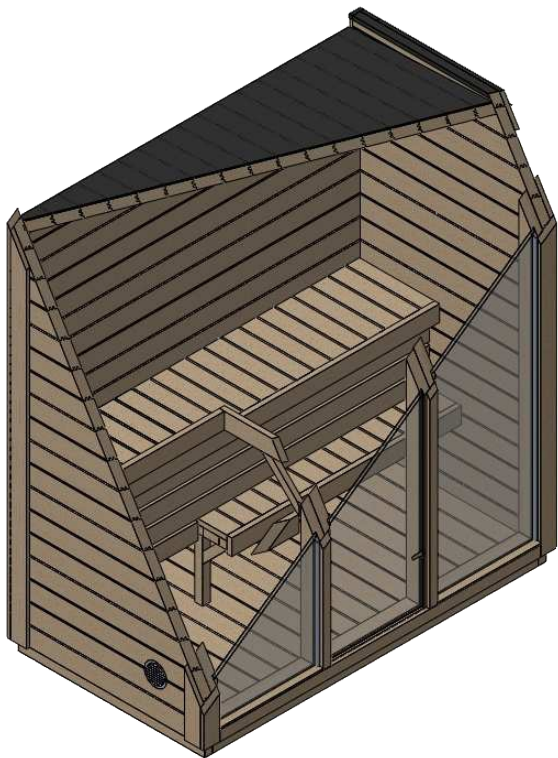

 **POLHUS**

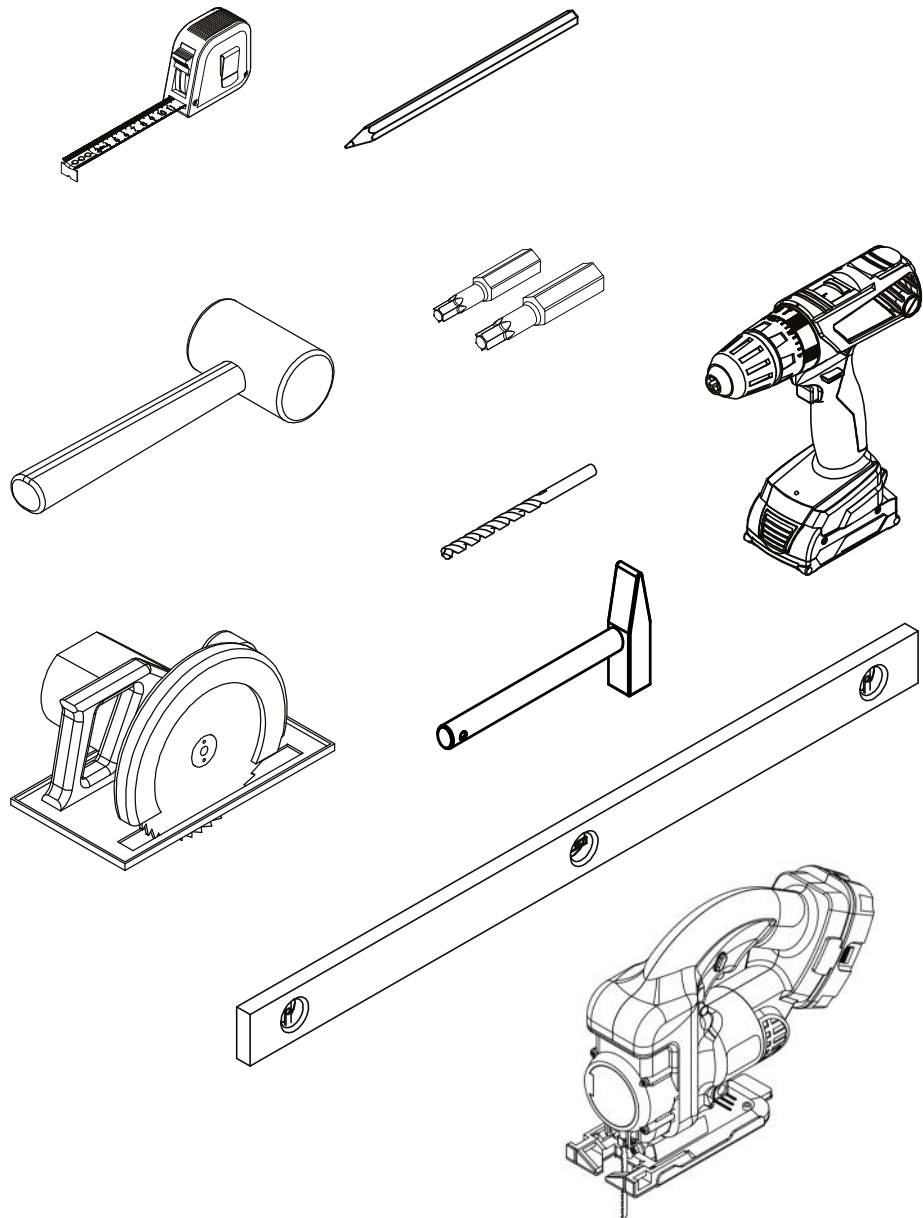

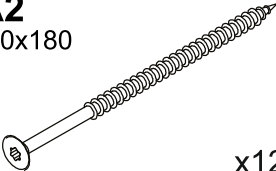
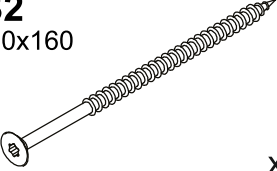
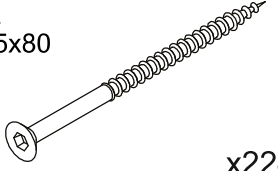
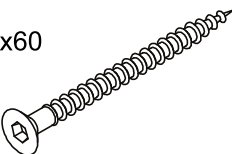
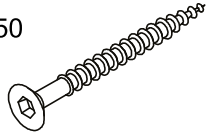
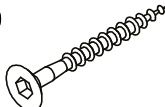
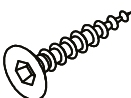

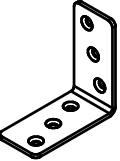

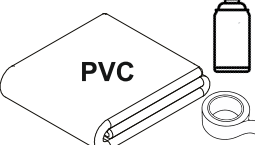

Tools needed for assembly (not included in the package). Werkzeuge, die den Aufbau erleichtern (nicht im Lieferumfang enthalten).



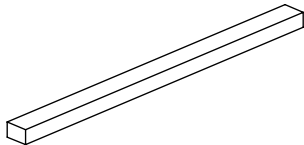

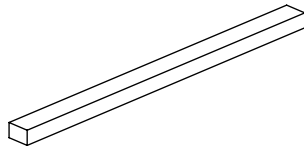

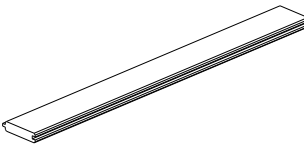
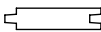
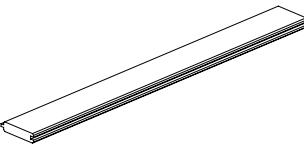

A2 6,0x180  x121	B2 6,0x160  x7	A 4,5x80  x224
B 4,5x60  x30	C 4,0x50  x74	D 3,0x40  x91
E 3,5x25  x32	G 4,8x35  x23	H  x17
J  x2	T  x1	
Q  x1	P  x5	K  PVC

Base and floor / Basis und Boden

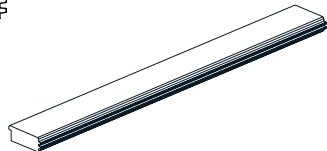

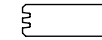
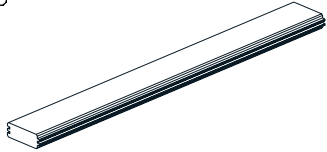
No.	H x W x L	Qt.	
1	44x68x1039	2	  <p>D.44.68.1039.00</p>
2	44x68x1828	5	  <p>D.44.68.1828.00</p>
3	28x88x1024	1	  <p>SL.28.1024.01</p>
4	28x122x1024	16	  <p>SL.28.1024.00</p>
-	-	-	-

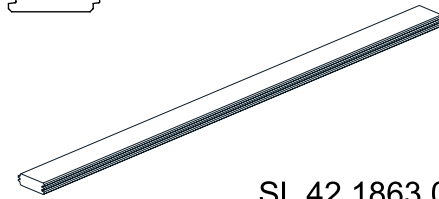
Walls / Wände

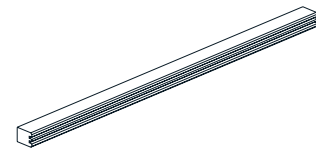
4



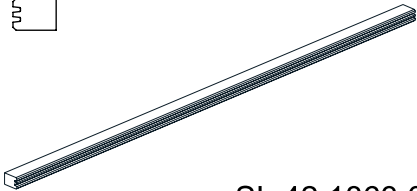

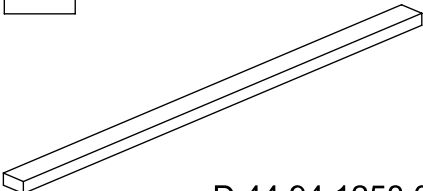
No.	H x W x L	Qt.	
5	42x120x1068	2	  <p>SL.42.1068.01</p>
6	42x120x1863	1	  <p>SL.42.1863.01</p>
7	42x120x1068	34	  <p>SL.42.1068.00</p>
8	42x122x1863	16	  <p>SL.42.1863.00</p>
9	42x59x1068	2	  <p>SL.42.1068.02</p>

Walls / Wände



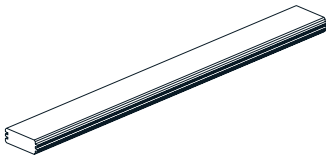

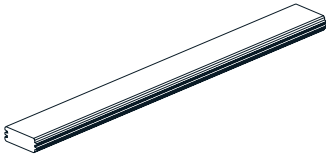

No.	H x W x L	Qt.	
10	42x61x1863	1	  <p>SL.42.1863.02</p>
11	44x94x1863	1	  <p>D.44.94.1258.00</p>
-	-	-	-
-	-	-	-
-	-	-	-

Roof / Dach

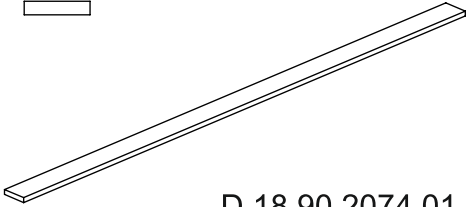
5

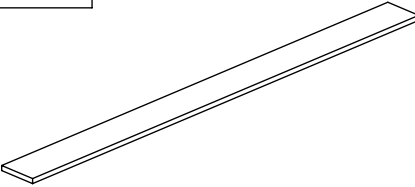

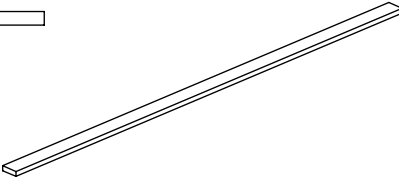

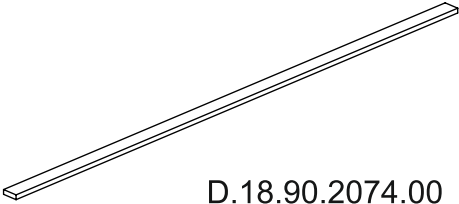
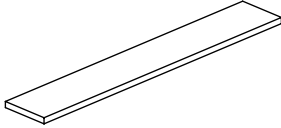

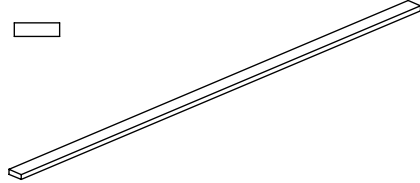

No.	H x W x L	Qt.	
12	42x88x1087	1	  <p>SL.42.1087.01</p>
13	42x122x1087	16	  <p>SL.42.1087.00</p>
14	34x42x1863	1	  <p>SL.42.1863.03</p>
-	-	-	-
-	-	-	-

Covers and edgeboards / Abdeckungen und Kantenbretter

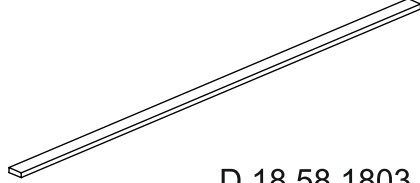

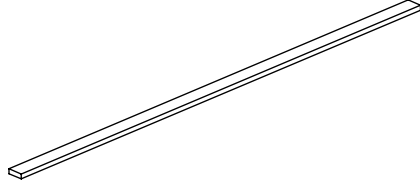

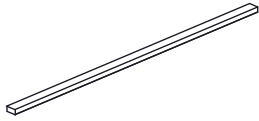

No.	H x W x L	Qt.	
15	18x87x2074	2	  D.18.90.2074.01
16	18x145x1803	1	  D.18.145.1803.00
17	18x63x1803	1	  D.18.90.1803.00
18	18x90x2074	4	  D.18.90.2074.00
19	18x145x888	2	 D.18.145.888.00

Covers and edgeboards /
Abdeckungen und Kantenbretter

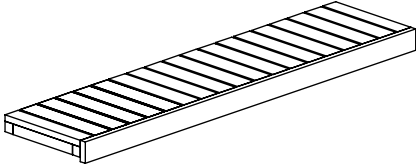
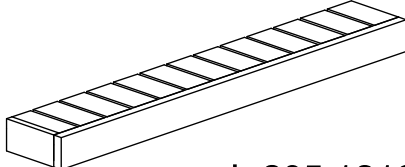
6

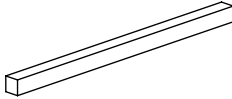





No.	H x W x L	Qt.	
20	18x90x2074	2	  D.18.90.2074.02
21	18x58x1803	1	  D.18.58.1803.00
22	18x44x1865	2	  D.18.44.1865.00
41	18x44x930	2	  D.18.44.930.00
42	18x44x1827	2	  D.18.44.1827.00

Bench / Saunabank

No.	H x W x L	Qt.	
23	90x450x1855	1	 <p>L.450.1855</p>
24	90x205x1318	1	 <p>L.205.1318</p>
25	44x44x813	4	  <p>D.44.44.813.00</p>
26	44x44x350	2	  <p>D.44.44.350.00</p>
27	44x44x250	2	 <p>D.44.44.250.00</p>

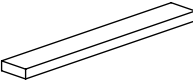
Bench and heater guard /
Saunabank und Heizschutz

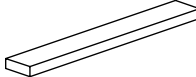
7

No.	H x W x L	Qt.	
28	44x44x120	3	 <p>D.44.44.120.00</p>
29	28x90x635	3	  <p>D.28.90.635.00</p>
30	28x90x450	1	  <p>D.28.90.450.00</p>
31	28x40x350	1	  <p>D.28.40.350.00</p>
-	-	-	-

Door and windows / Tür und Fenster

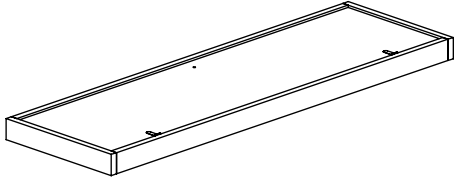
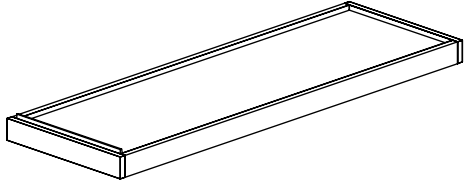

No.	H x W x L	Qt.	
32	590x1920	1	 <p>DKL6_19TR</p>
33	92x636x1920	2	
-	-	-	-
-	-	-	-
-	-	-	-

Roof edges / Dachkanten

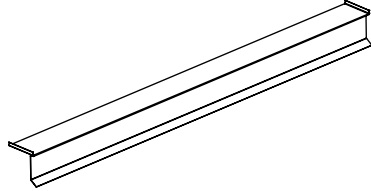
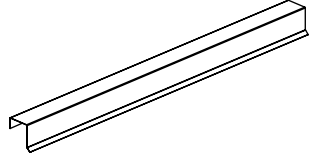
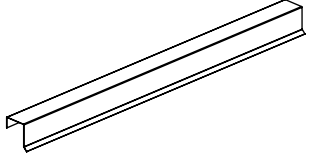
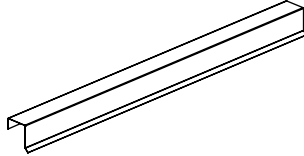
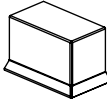
8

No.	H x W x L	Qt.	
34	99x102x1863	1	
35L	65x65x1100	1	
35R	65x65x1100	1	
36	65x65x1855	1	
37L	75x77x127	1	

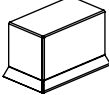
Roof edges / Dachkanten

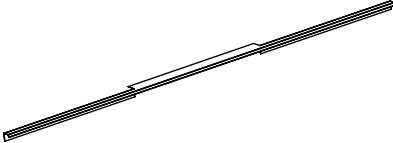
No.	H x W x L	Qt.		
37R	75x77x127	1		-
38L	30x63x65	1		-
38R	30x63x65	1		-
43	28x54x1806	1		-
-	-	-		-

Bench / Saunabank

9

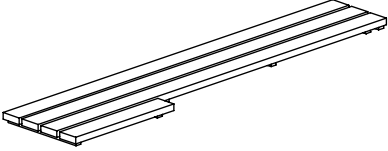
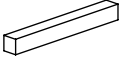
No.	H x W x L	Qt.		
39	408x1850	1		-
40	44x44x383	2	 D.44.44.384.00	-
-	-	-		-
-	-	-		-
-	-	-		-

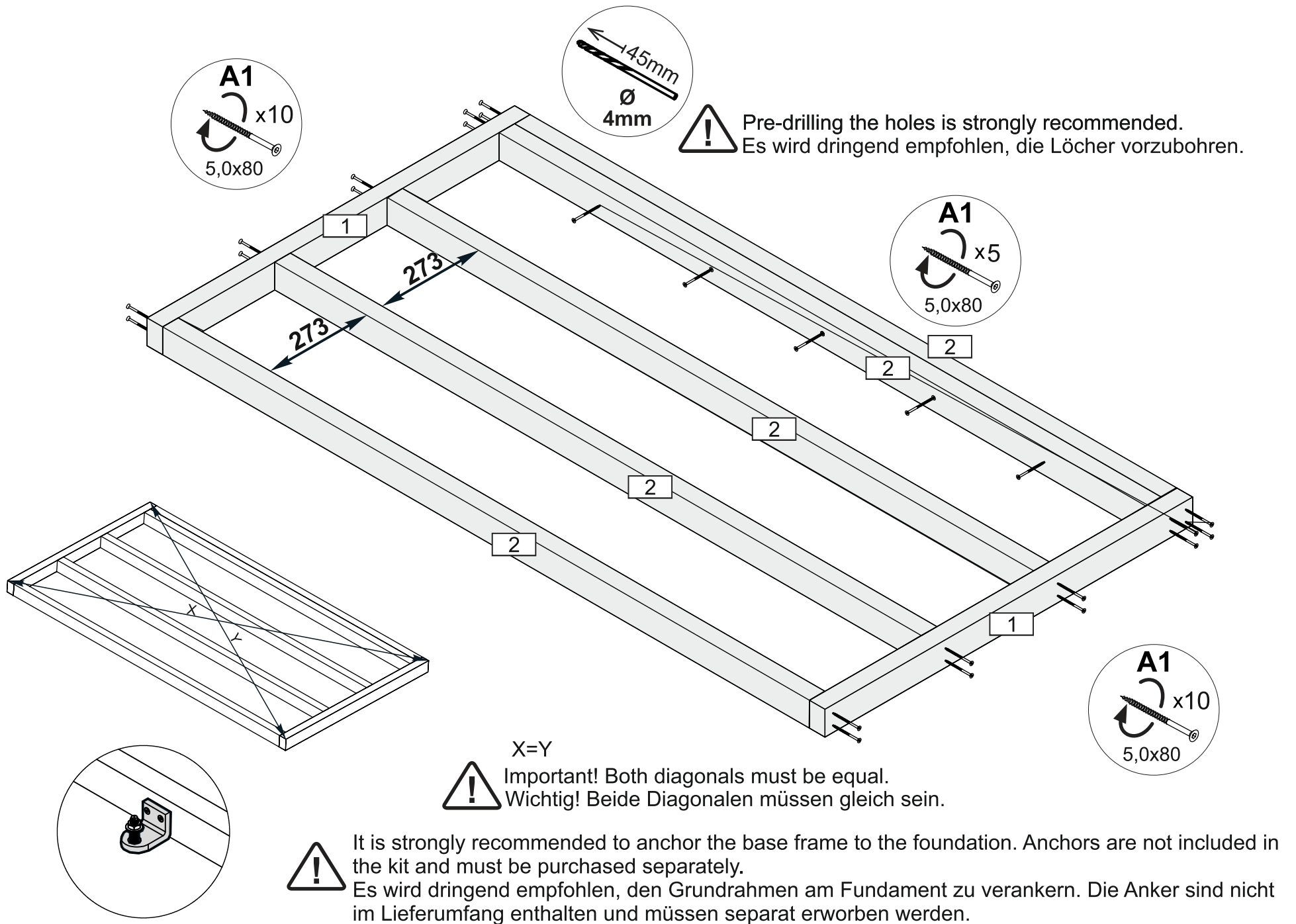

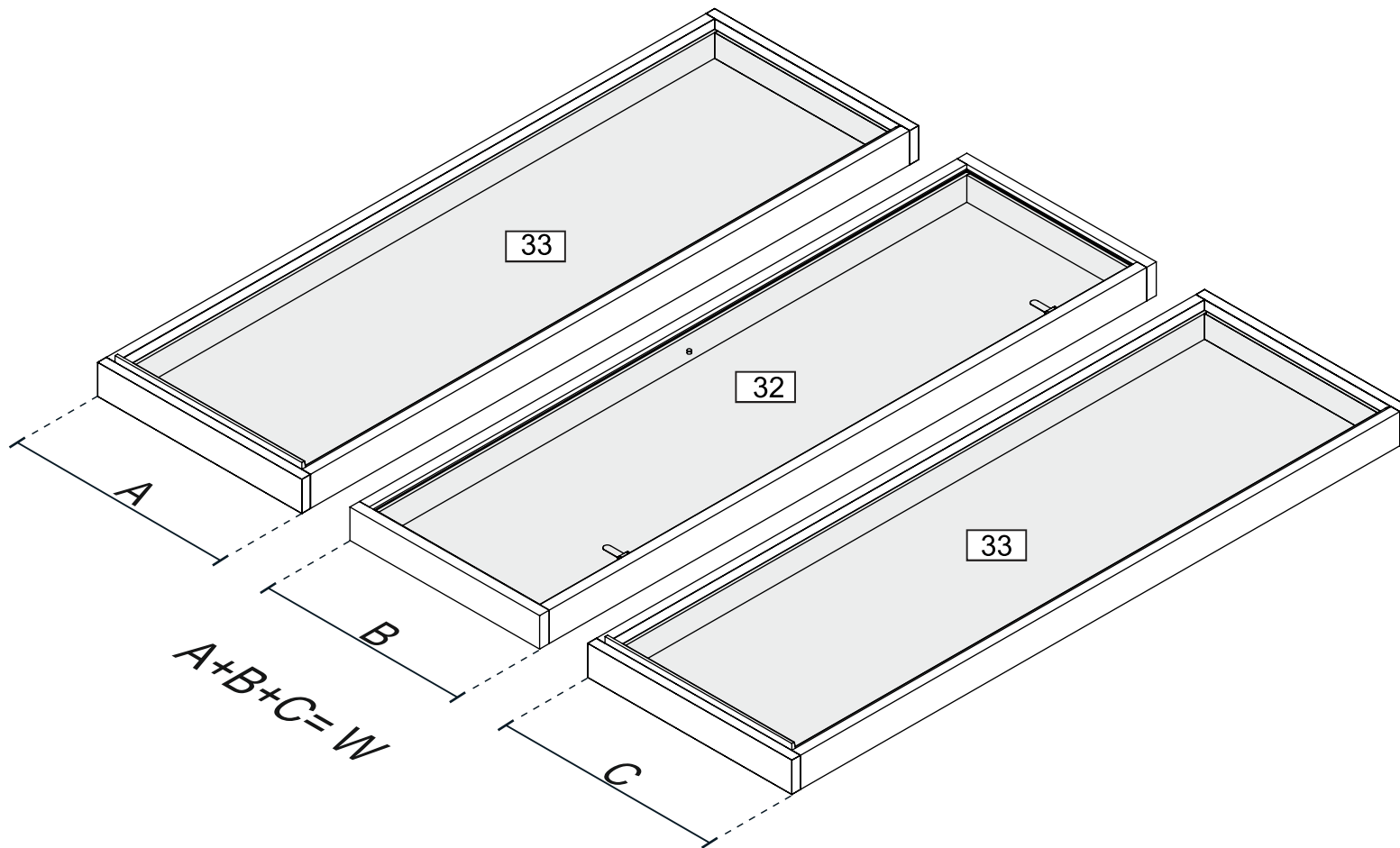

- 1.** Measure windows and the door, then add their measurements together to determine the total opening size.
Messen Sie die Fenster und die Tür und addieren Sie dann die Maße, um die Gesamtöffnungsgröße zu bestimmen.

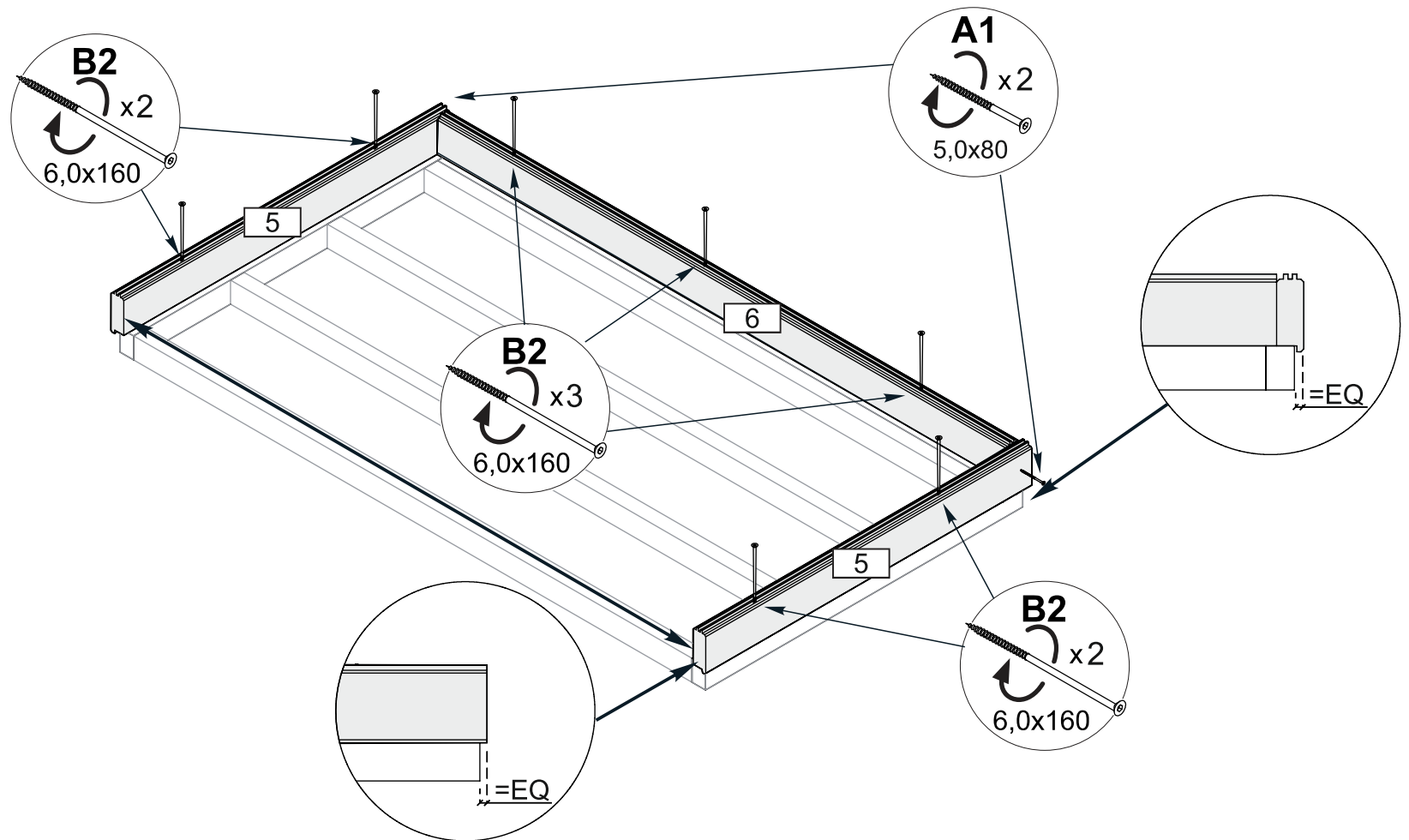

1. Align the parts so that the offsets are equal on both sides.
 1. Richten Sie die Teile so aus, dass die Abstände auf beiden Seiten gleich sind.

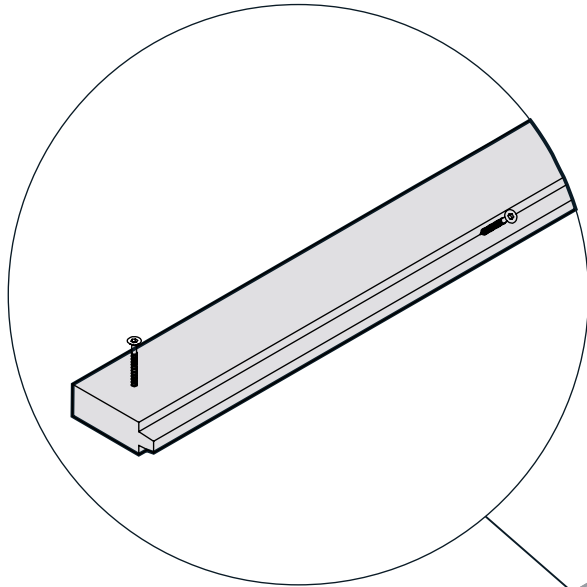

- 1.** Place 3 mm shims on the side and rear edge of the board.
Legen Sie 3 mm dicke Unterlegscheiben an die Seiten- und Hinterkante der Platine.

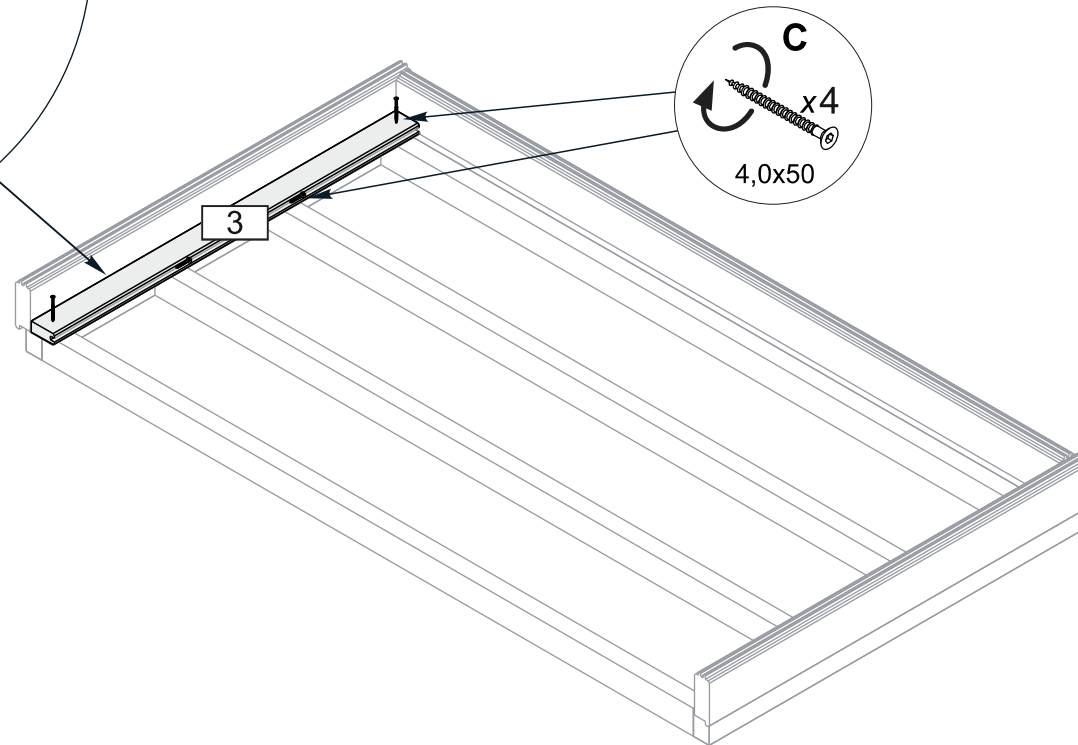

- 2.** Install the screws as shown in the diagram: the end screws go in from the top and the ones go into the groove.
Montieren Sie die Schrauben wie in der Abbildung gezeigt: Die Endschrauben werden von oben und die mittleren Schrauben von unten in die Nut eingedreht.

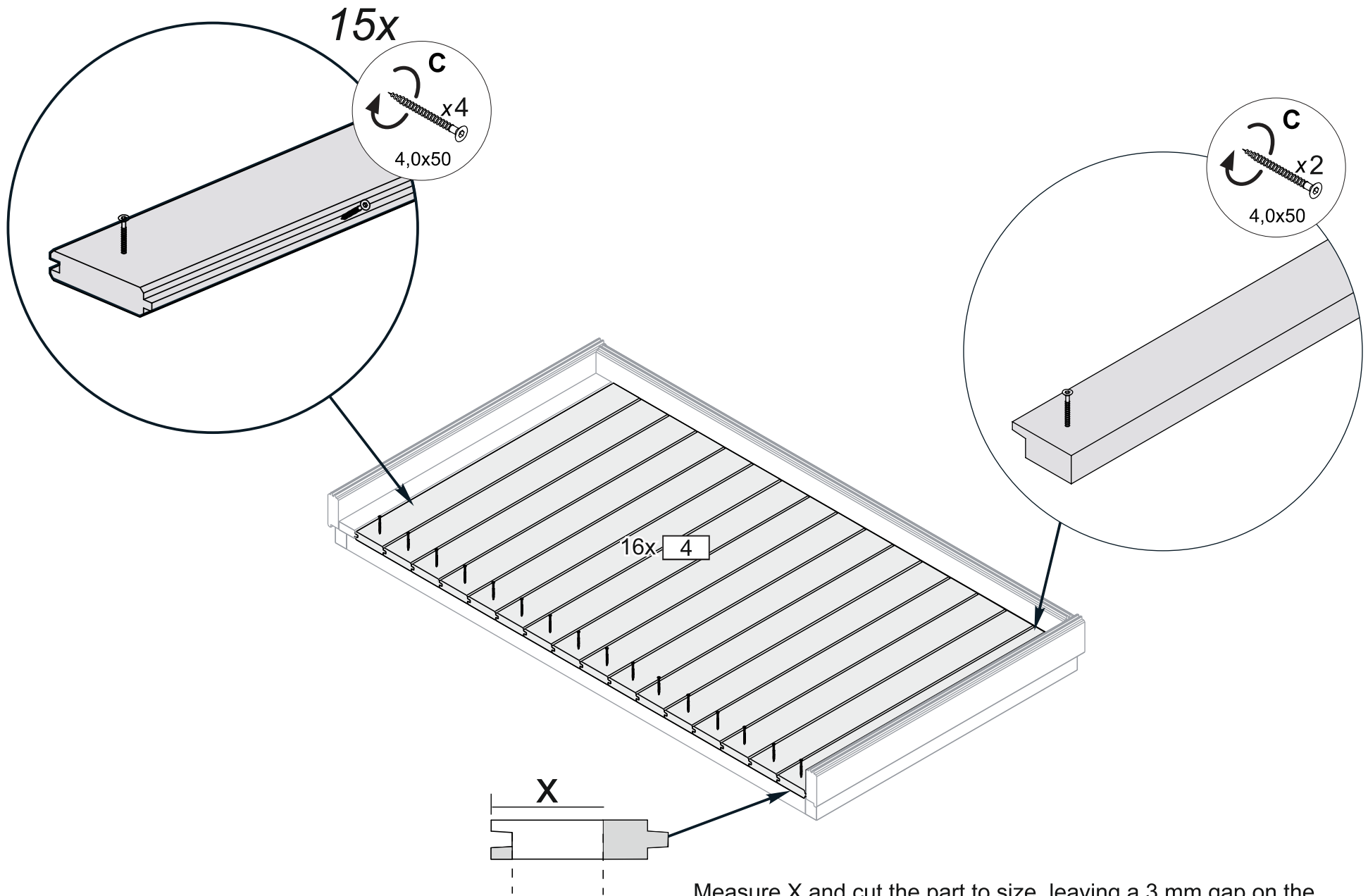

Measure X and cut the part to size, leaving a 3 mm gap on the side. Messen Sie X und schneiden Sie das Teil auf die richtige Größe zu. Lassen Sie seitlich 3 mm frei.

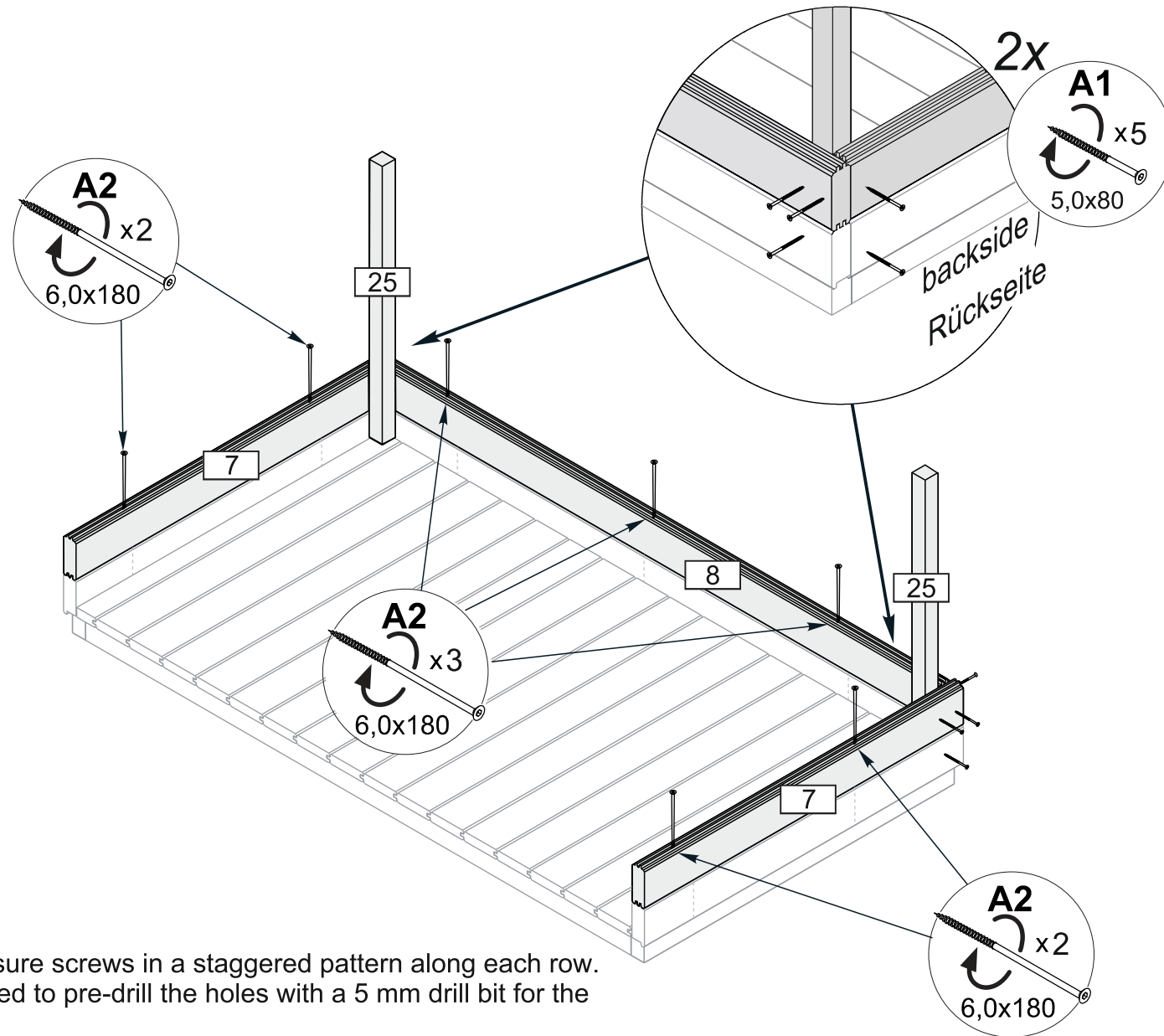

Install the enclosure screws in a staggered pattern along each row. It is recommended to pre-drill the holes with a 5 mm drill bit for the long screws.

Bringen Sie die Gehäuseschrauben versetzt entlang jeder Reihe an.
Es wird empfohlen, für die langen Schrauben die Löcher mit einem 5-mm-Bohrer vorzubohren.

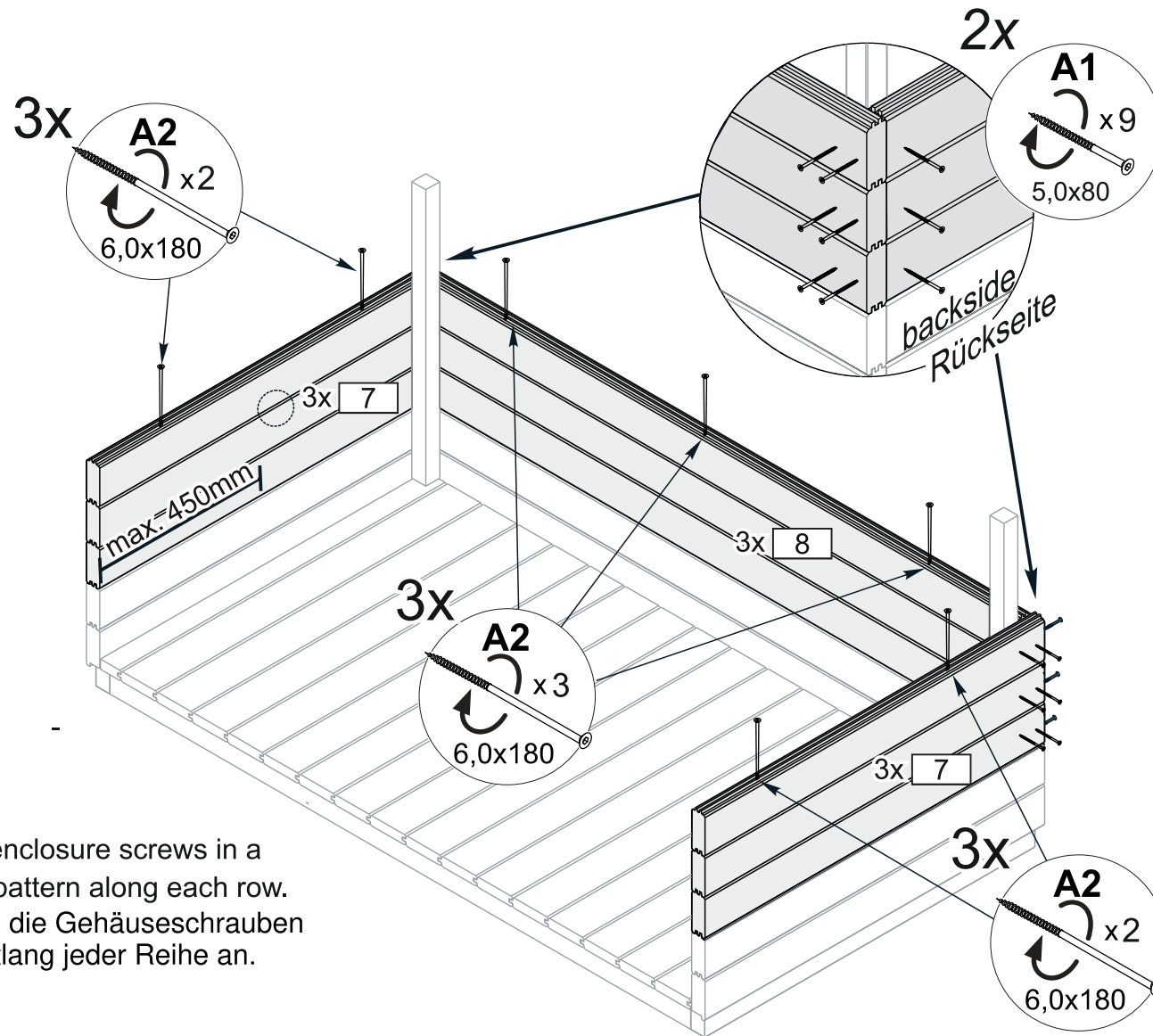

Install the enclosure screws in a staggered pattern along each row.
 Bringen Sie die Gehäuseschrauben versetzt entlang jeder Reihe an.



Install the screws so that they do not exceed the maximum indicated in the diagram.
 Montieren Sie die Schrauben so, dass sie das in der Zeichnung angegebene Maximum nicht überschreiten.

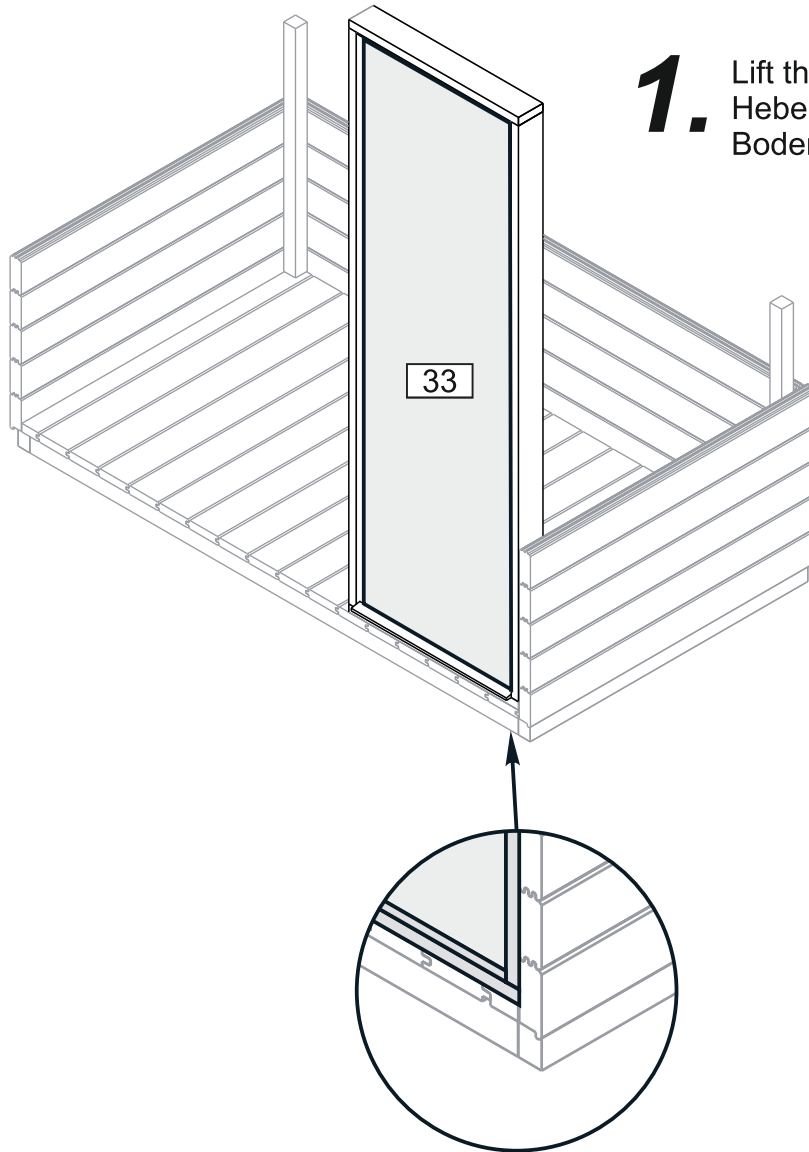

- 1.** Lift the window into place with the side flush with the floor and wall edge.
Heben Sie das Fenster an seinen Platz, sodass die Seite bündig mit dem Boden und der Wandkante abschließt.

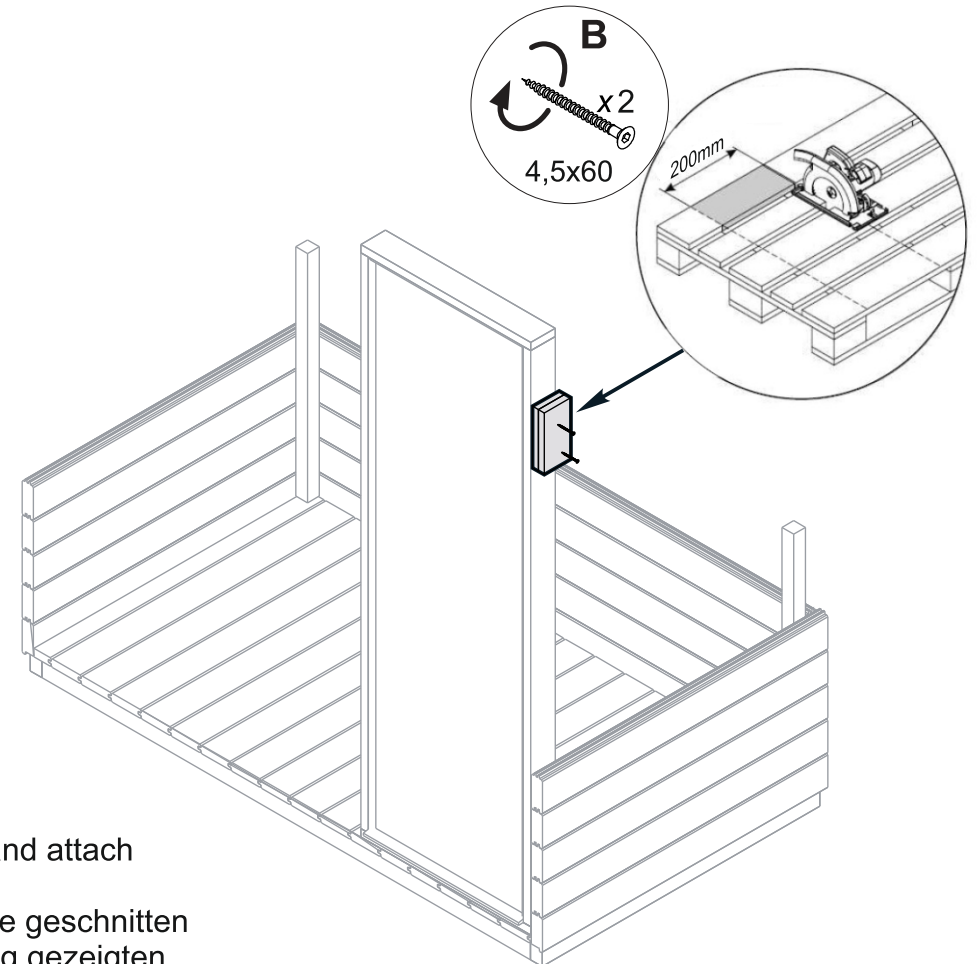

- 2.** Use two 200 mm long boards that can be cut from the pallet and attach them to the location shown in the diagram.
Verwenden Sie zwei 200 mm lange Bretter, die aus der Palette geschnitten werden können, und befestigen Sie sie an der in der Abbildung gezeigten Stelle.

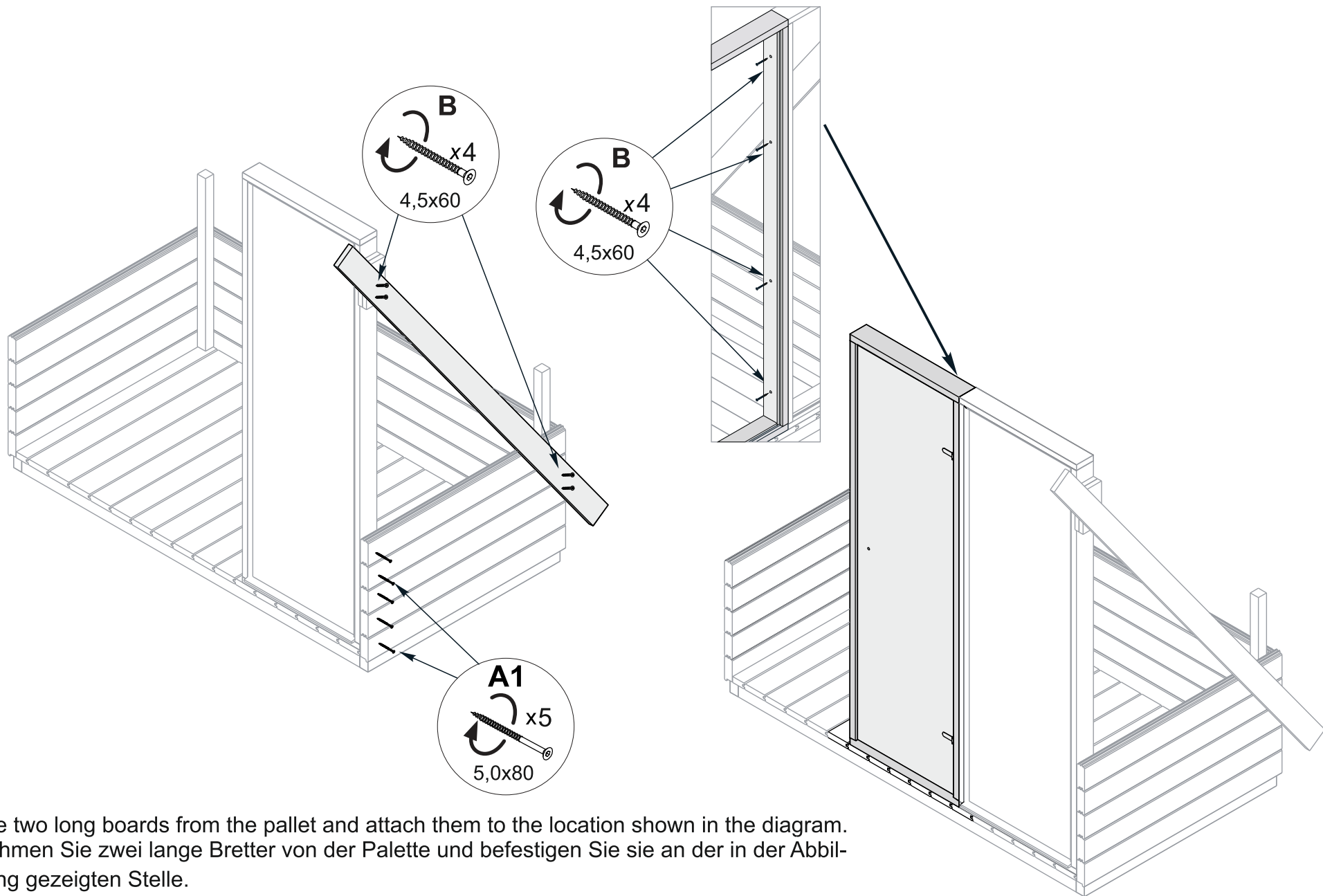

Use two long boards from the pallet and attach them to the location shown in the diagram.
Nehmen Sie zwei lange Bretter von der Palette und befestigen Sie sie an der in der Abbildung gezeigten Stelle.

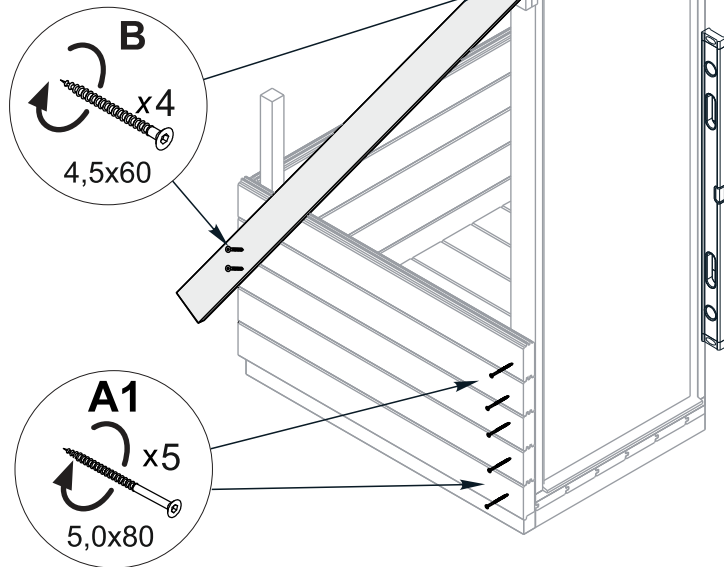
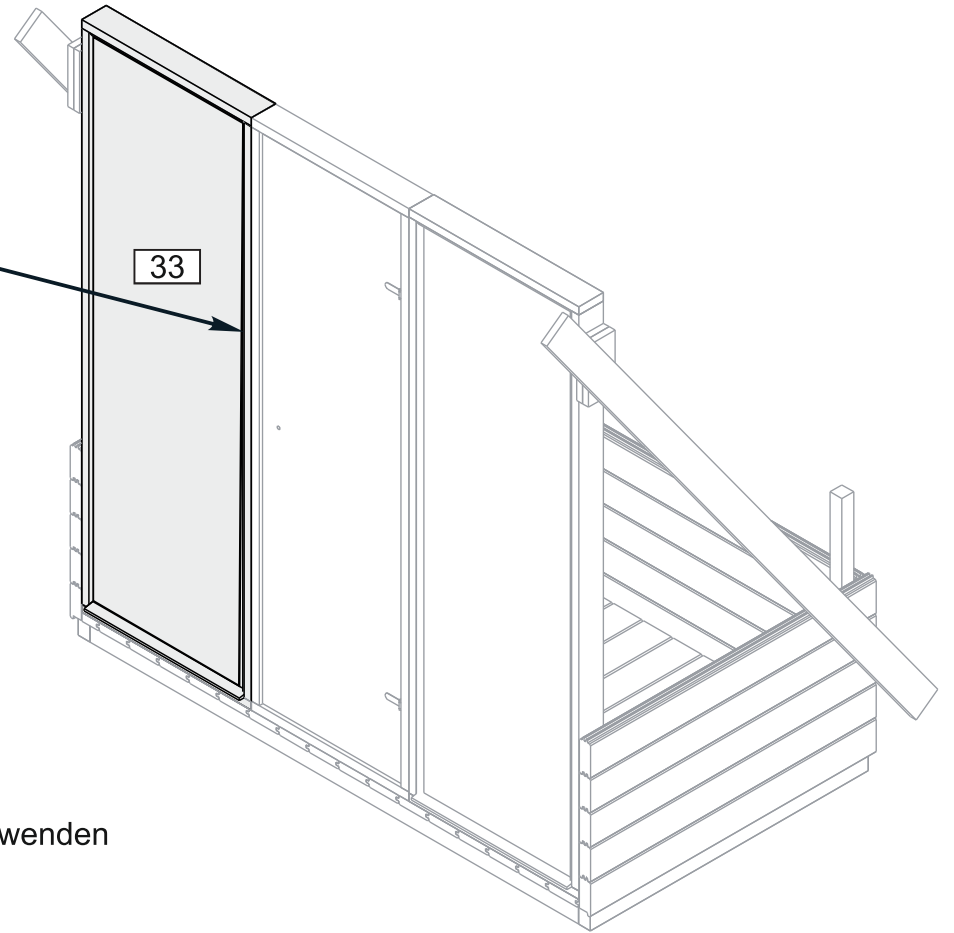
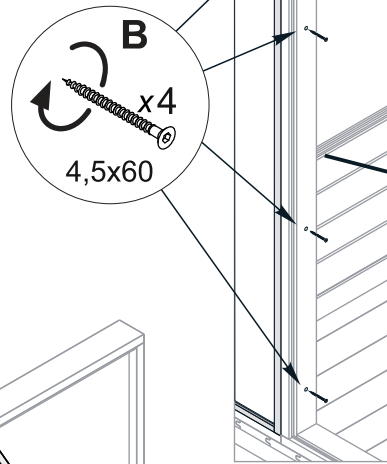
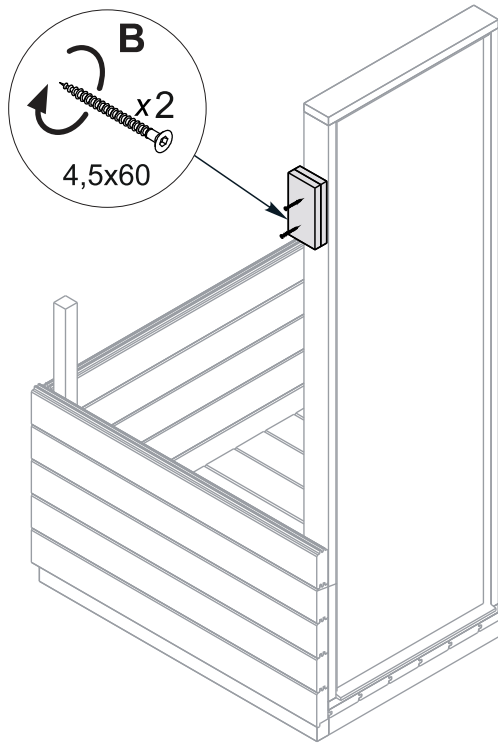

Use spirit level.

Wasserwaage verwenden

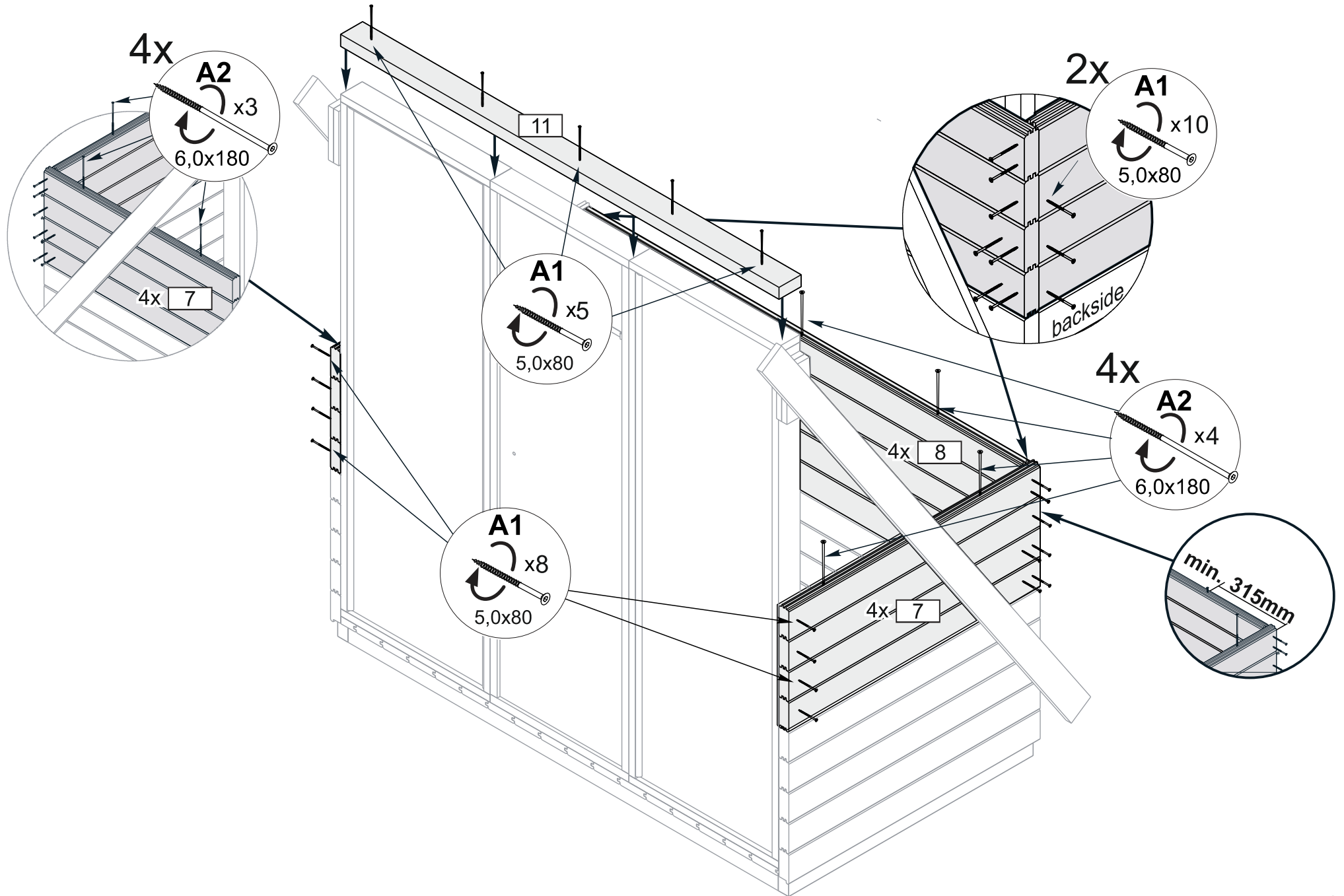

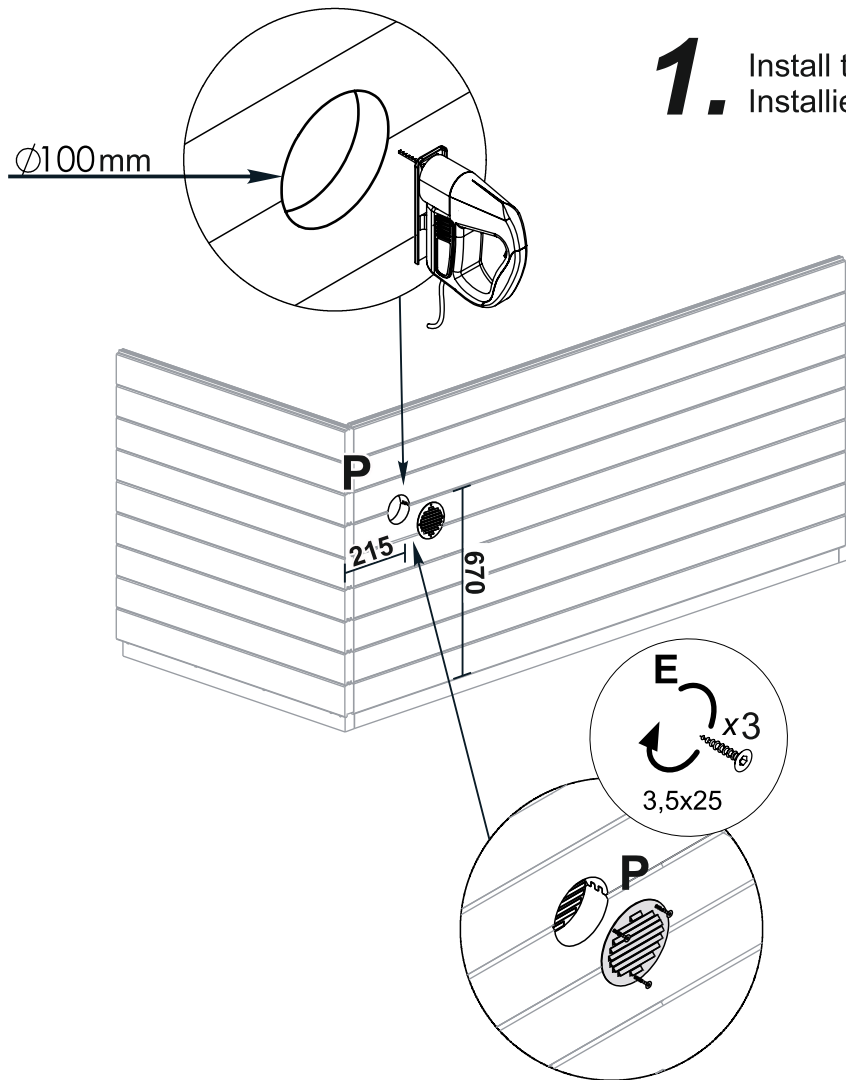

1. Install the ventilation grilles.
Installieren Sie die Lüftungsgitter.

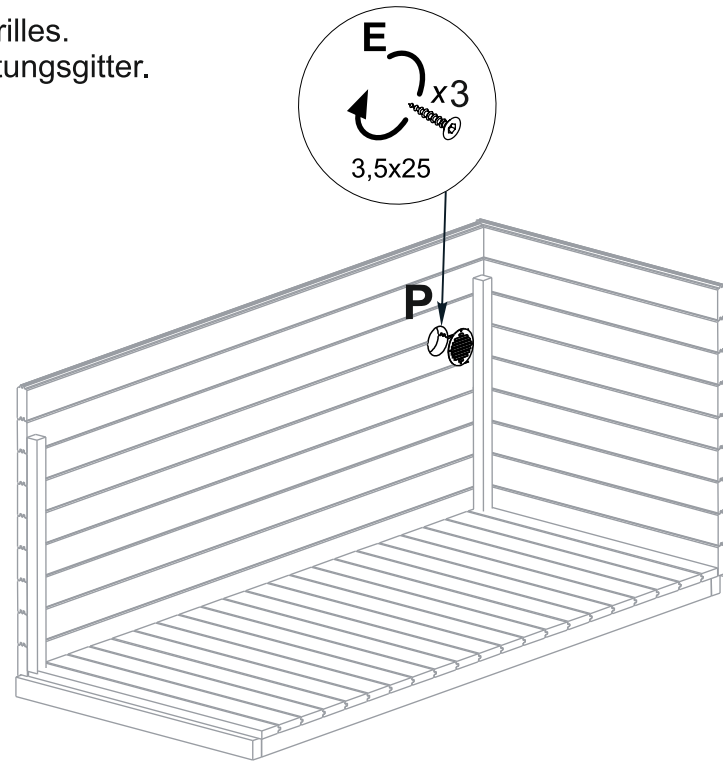

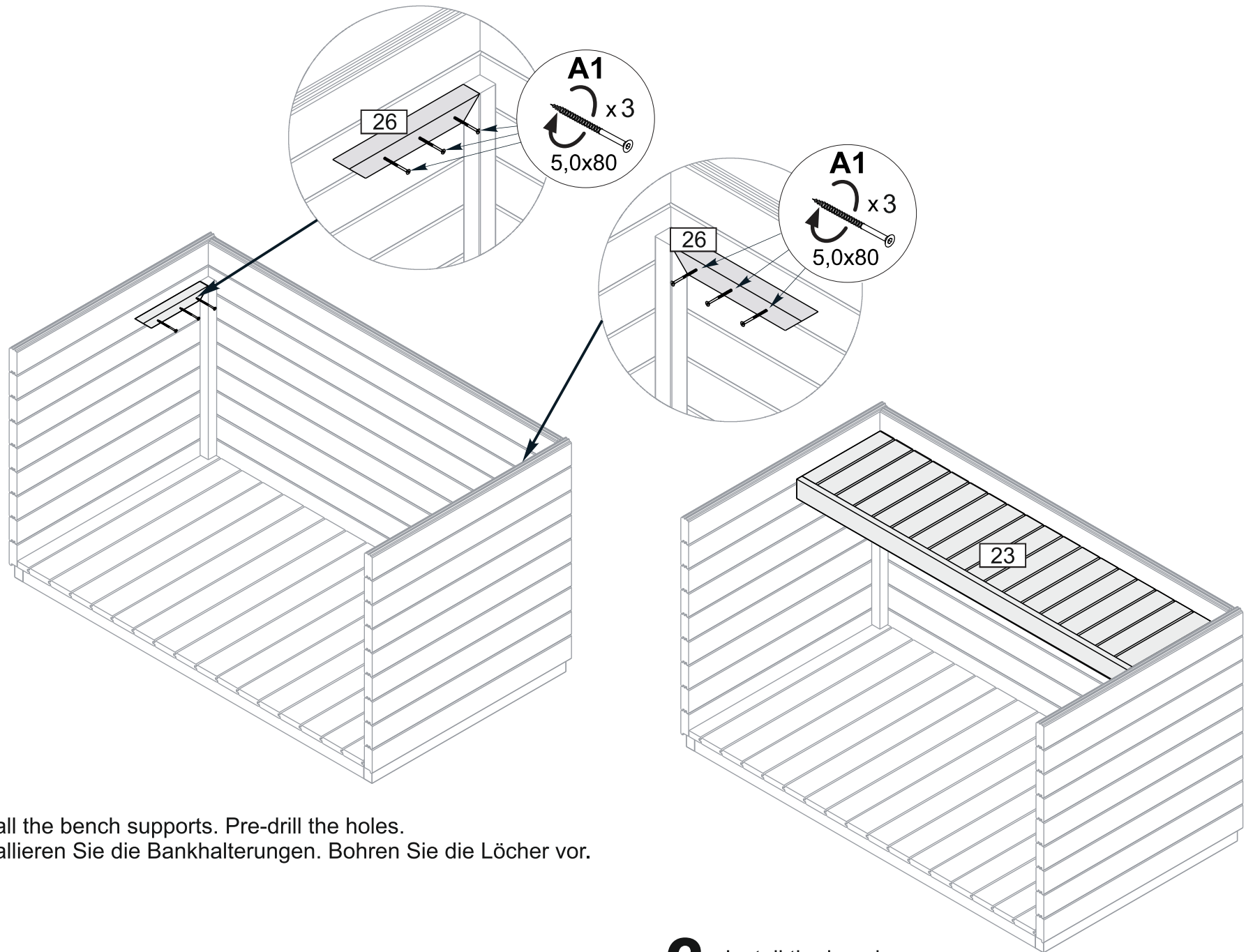

1. Install the bench supports. Pre-drill the holes.
Installieren Sie die Bankhalterungen. Bohren Sie die Löcher vor.

2. Install the benches.
Installieren Sie die Bänke.

1. Secure the bench to the walls.
Befestigen Sie die Bank an den Wänden.

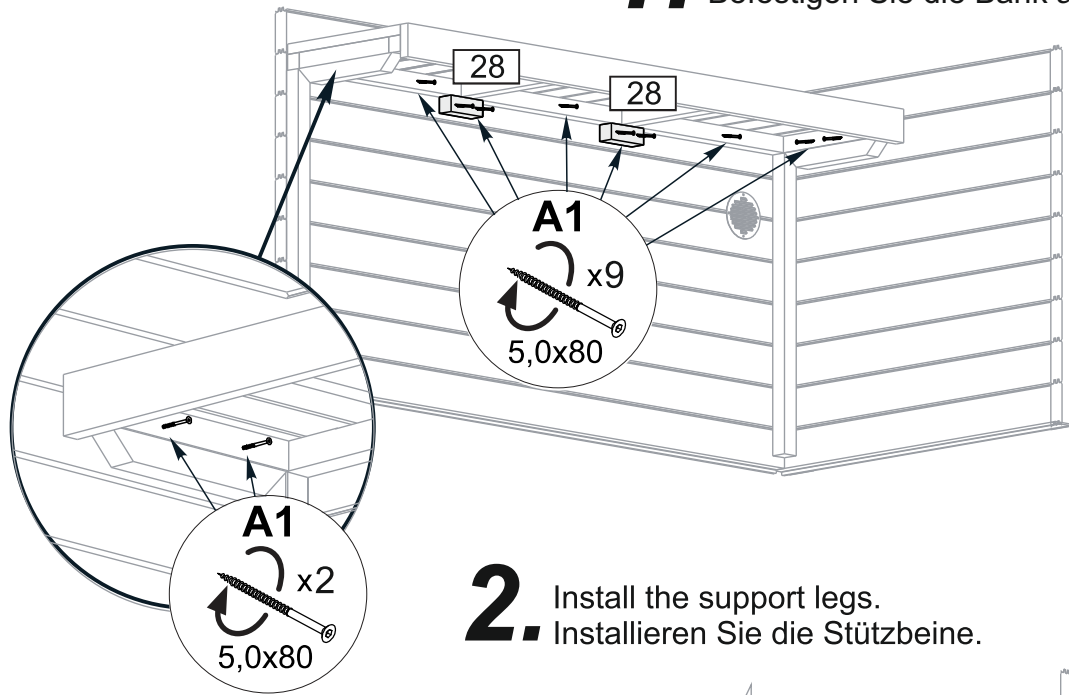

2. Install the support legs.
Installieren Sie die Stützbeine.

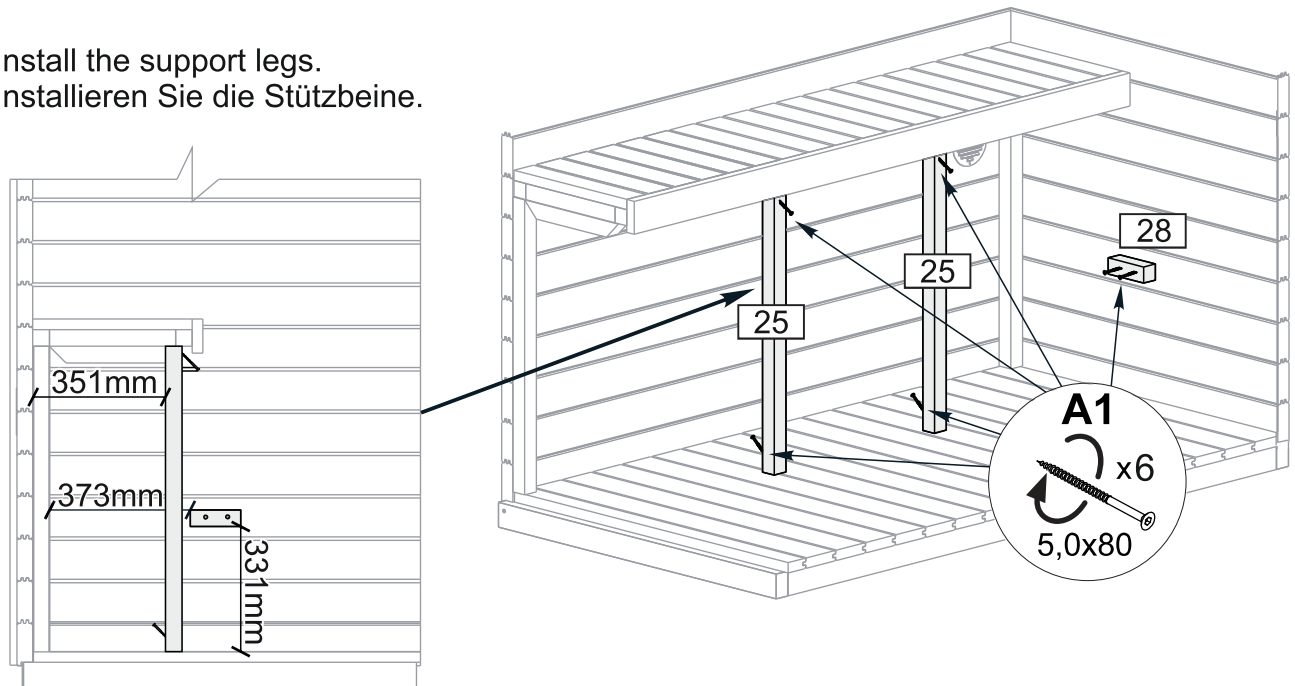

- 1** Install the bottom bench.
■ Installieren Sie die untere Bank.

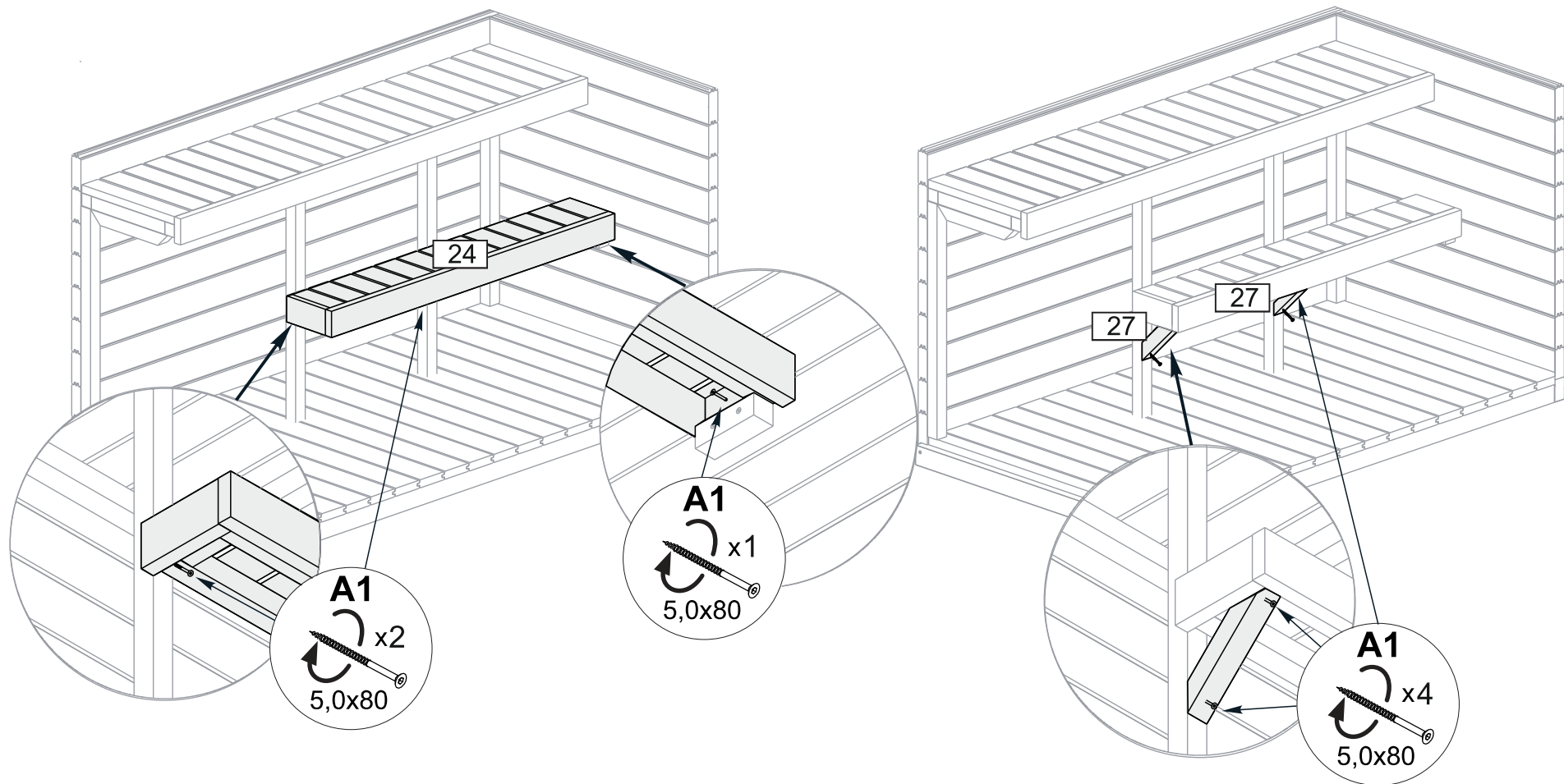

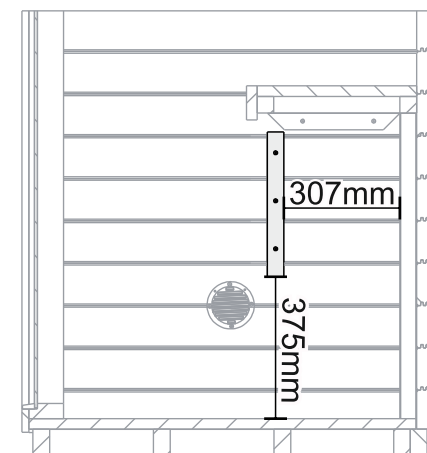
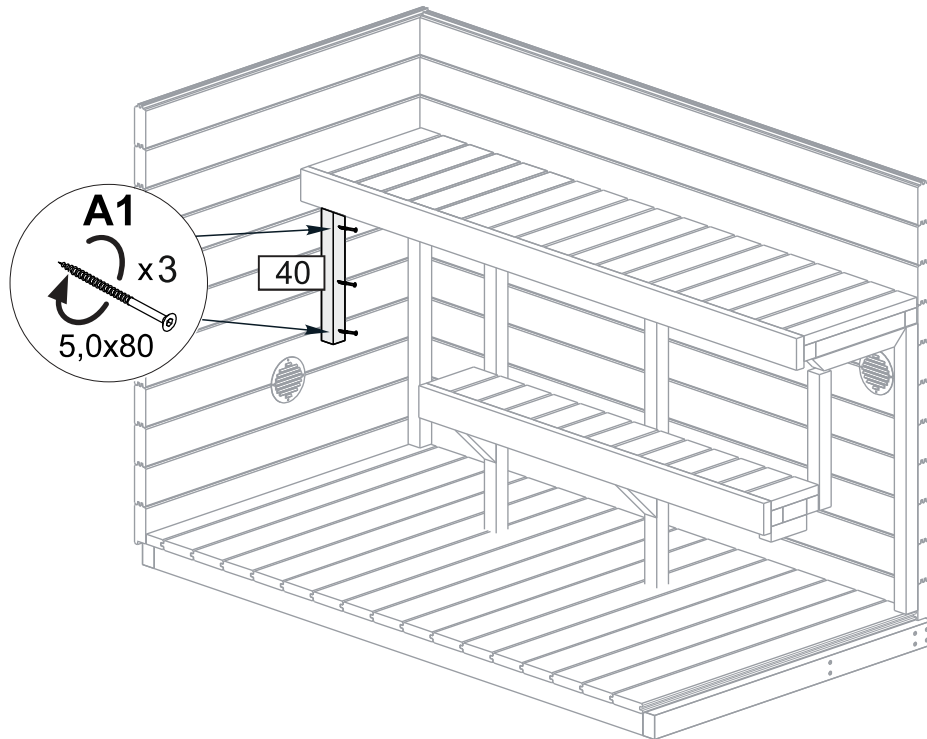
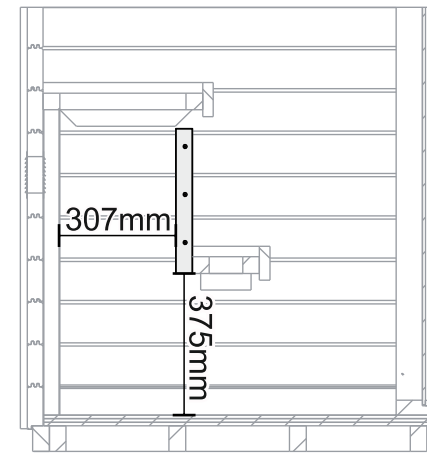
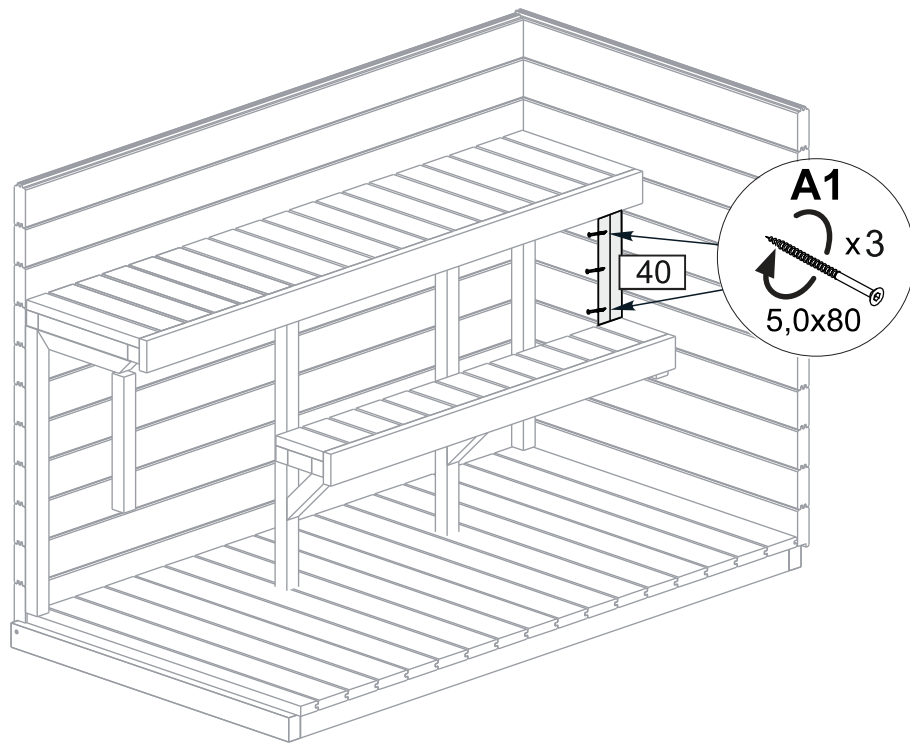

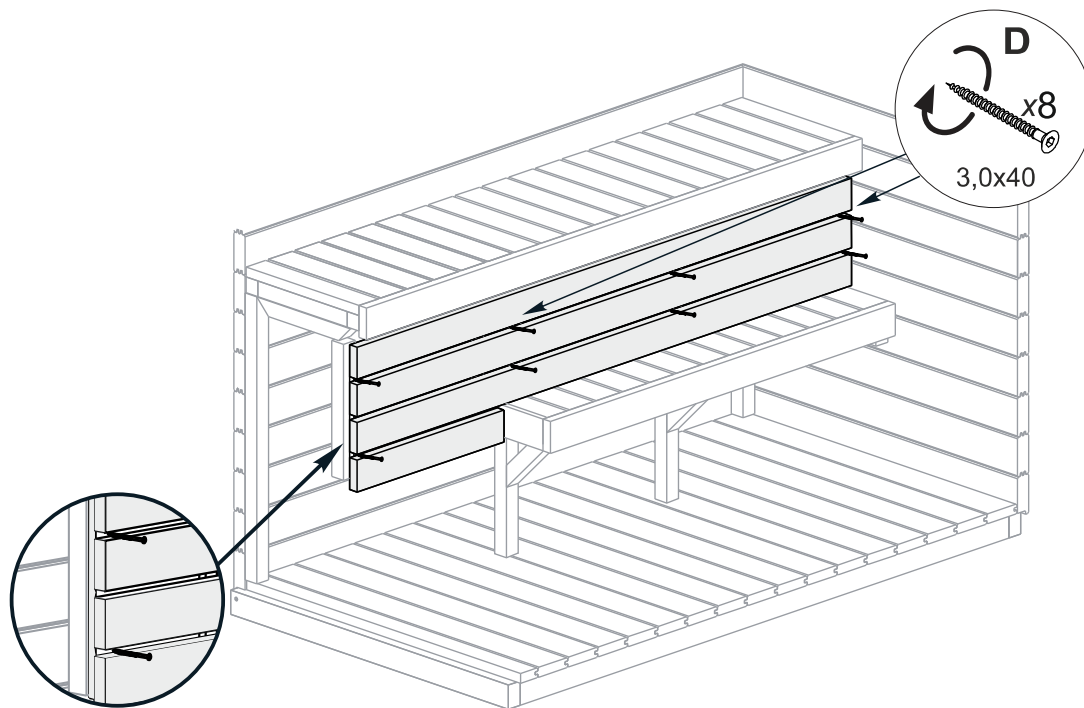

Install the front skirt.
 Installieren Sie die vordere Verkleidung.

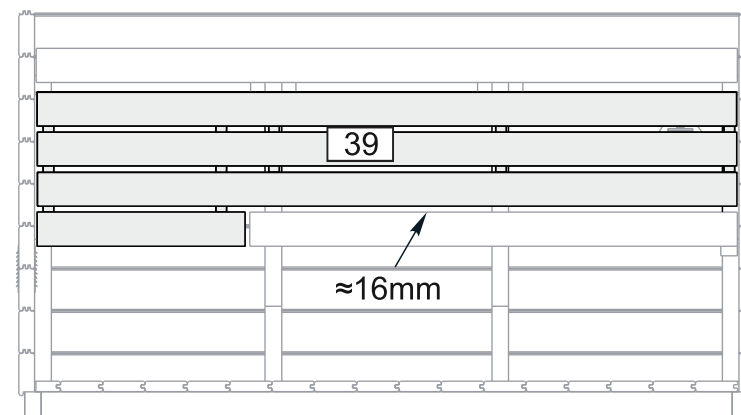

Leave a gap of about 16 mm between the lower bench and the skirt.
 Lassen Sie zwischen der unteren Bank und der Schürze einen Abstand von etwa 16 mm.

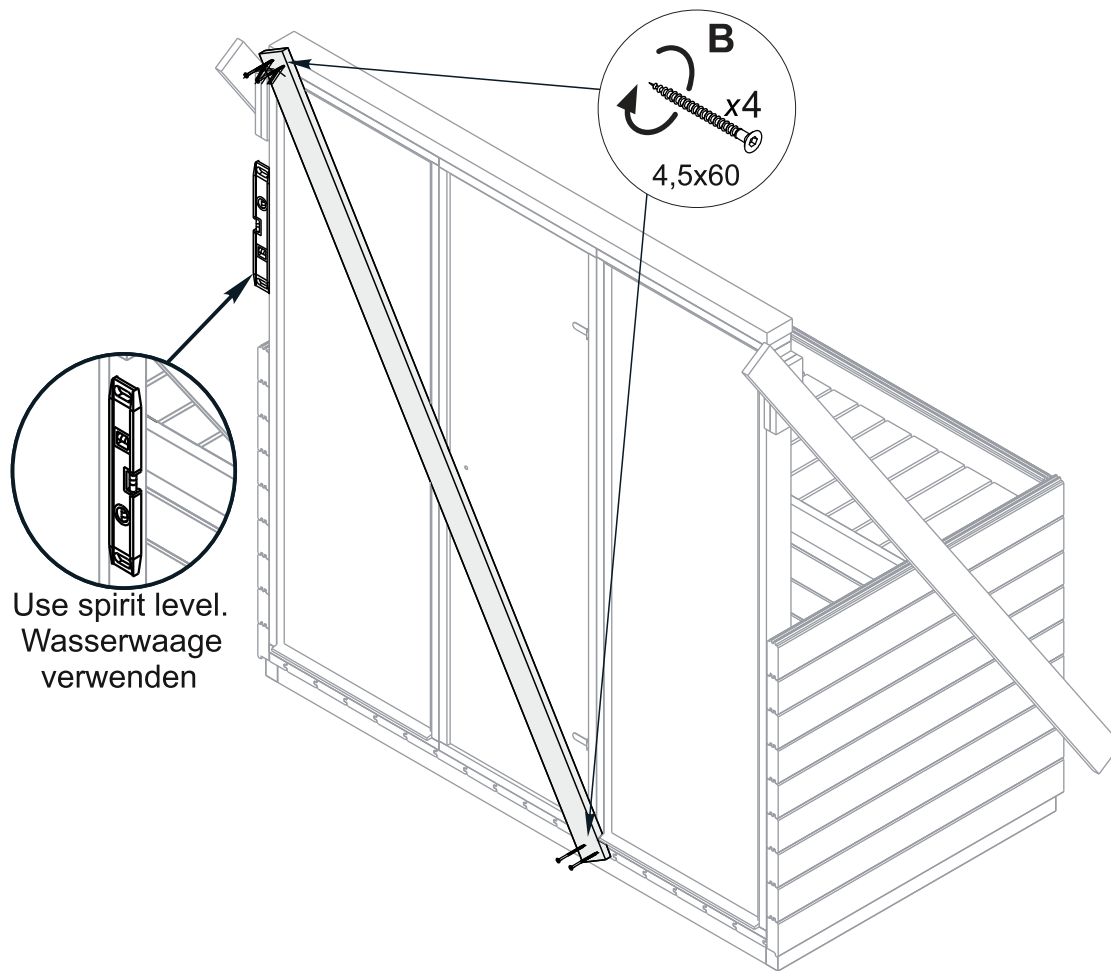

Use spirit level.
Wasserwaage
verwenden

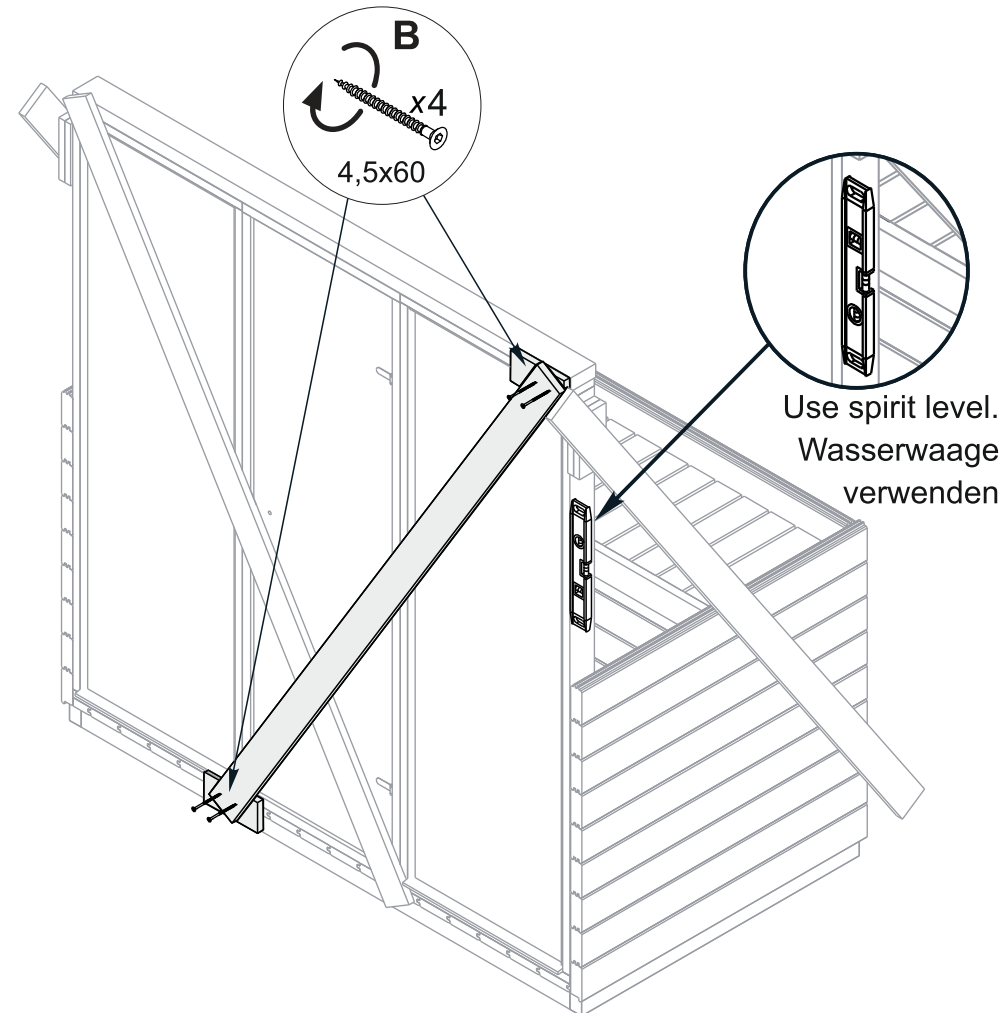

Use spirit level.
Wasserwaage
verwenden

1. Remove two full-length boards from the pallet and use them as diagonal braces to maintain the building's vertical alignment.
Nehmen Sie zwei durchgehende Bretter von der Palette und verwenden Sie sie als Diagonalstreben, um die senkrechte Ausrichtung des Gebäudes beizubehalten.

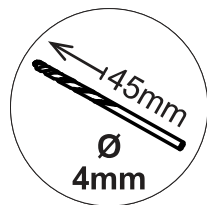
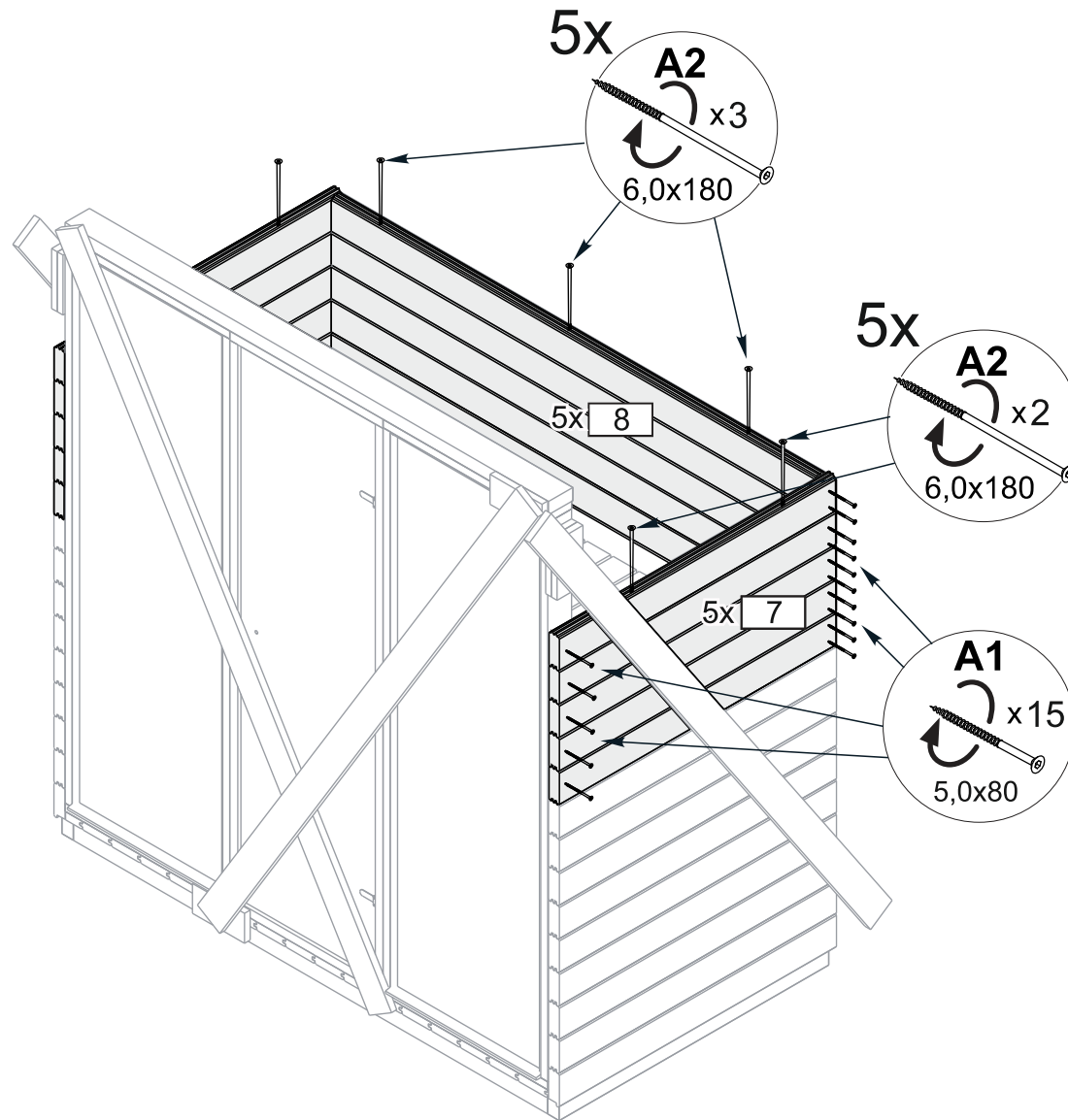
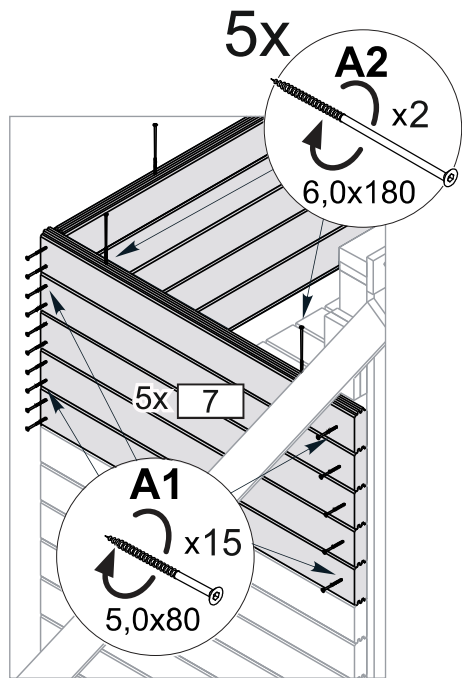

Pre-drilling the holes is strongly recommended.
Es wird dringend empfohlen, die Löcher vorzubohren.

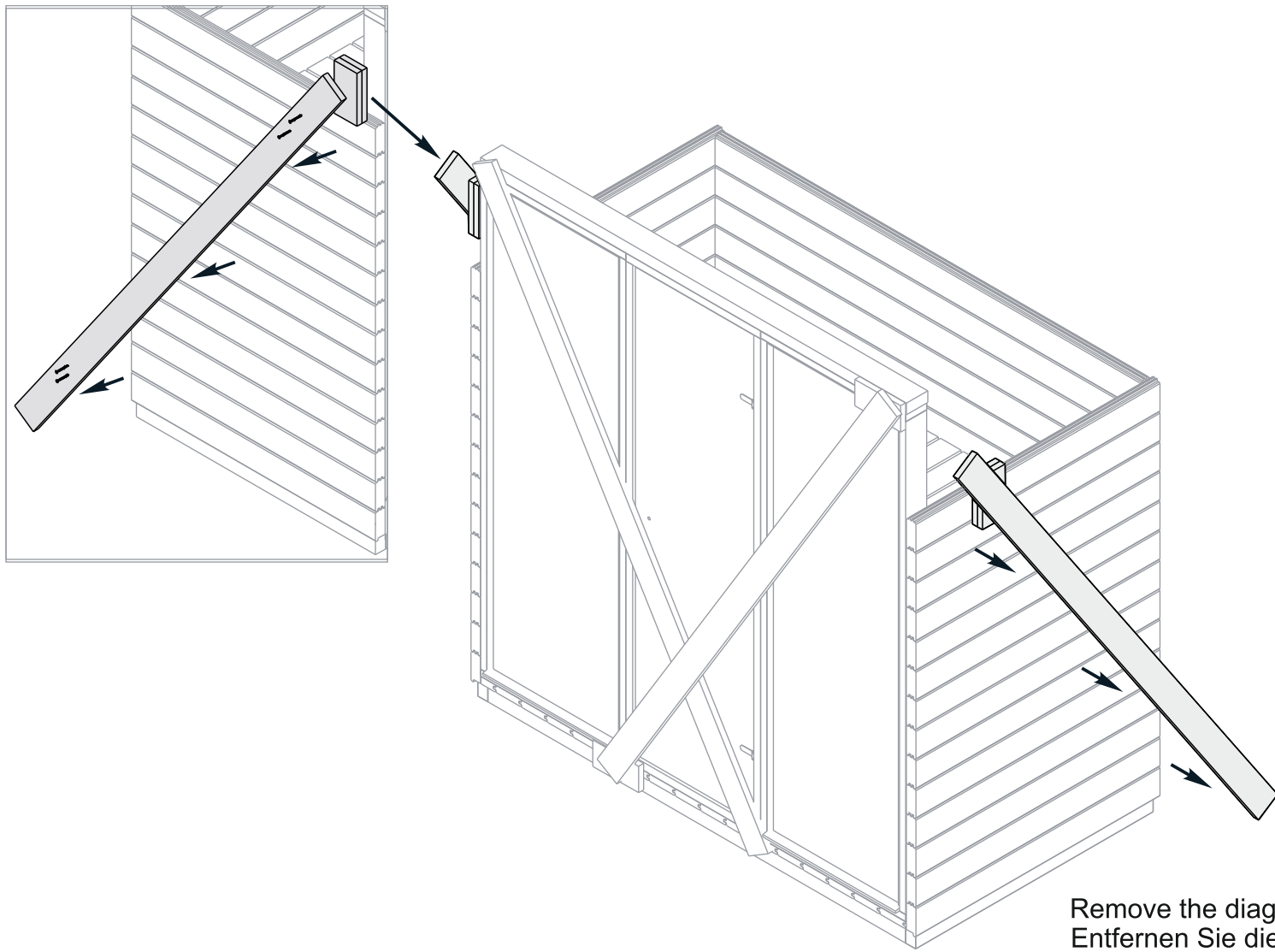

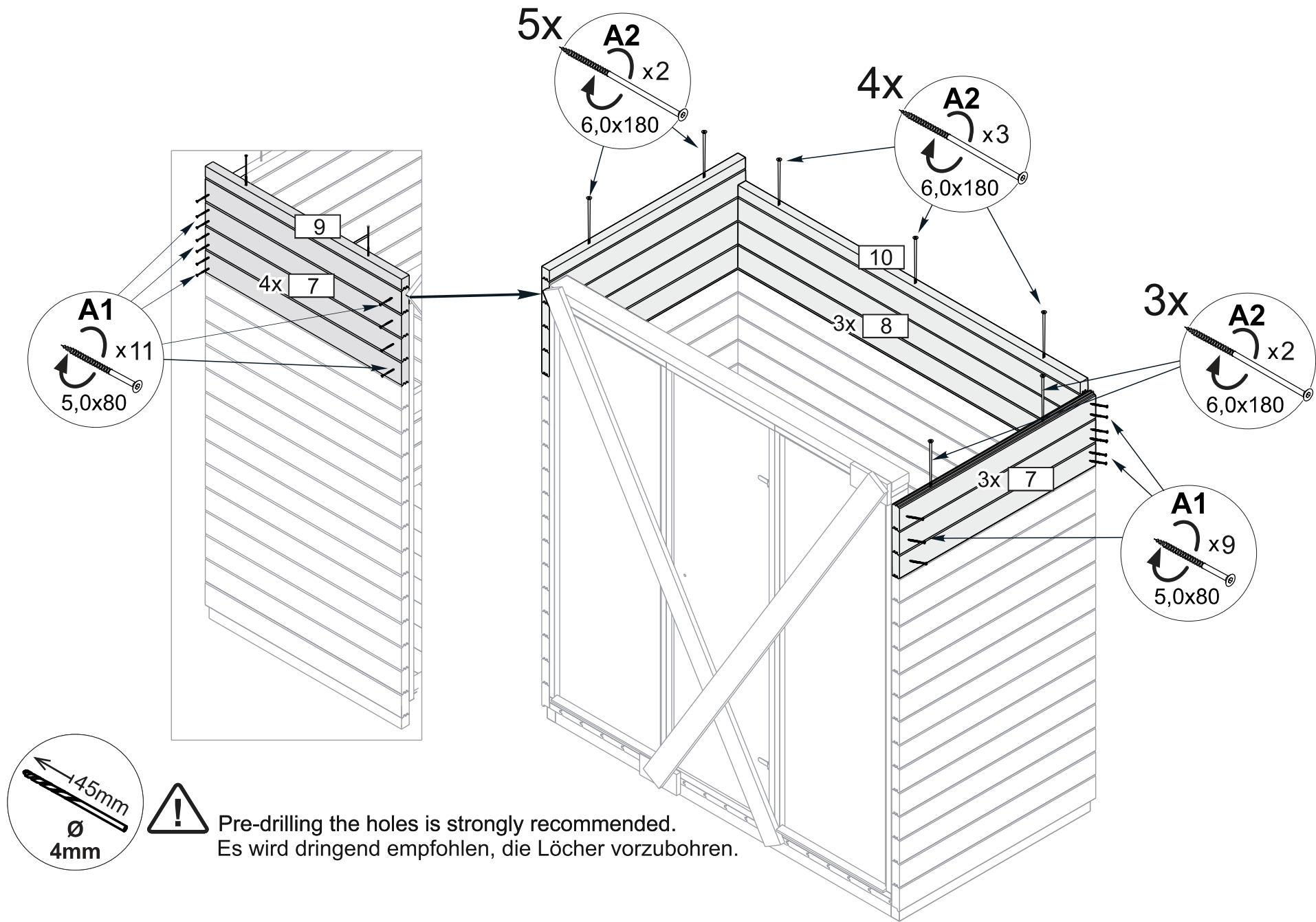

Leave 2mm gap from side
Lassen Sie 2 mm Abstand von der Seite

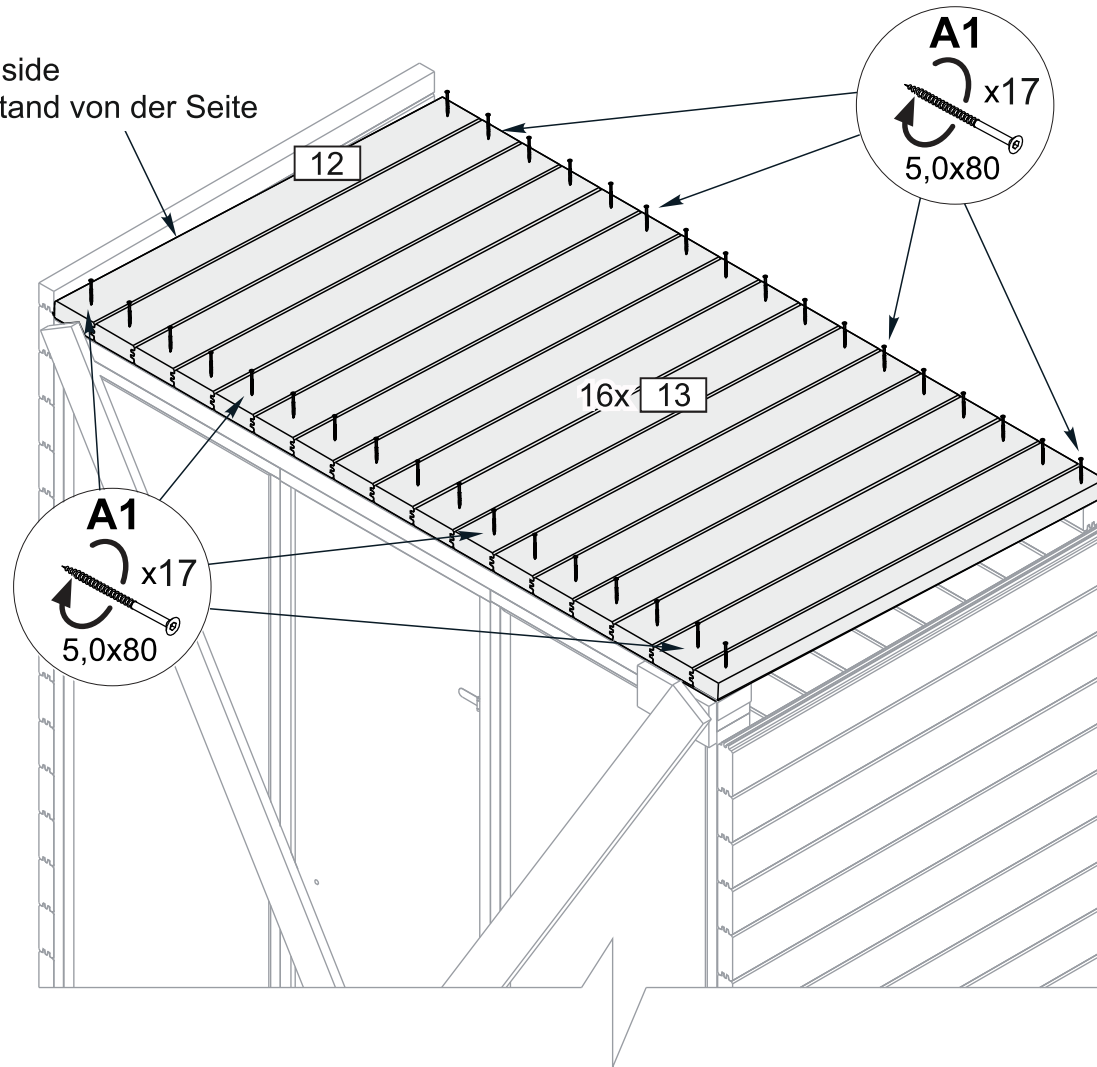

Measure x and cut the part to size,
leave 2mm gap from side.

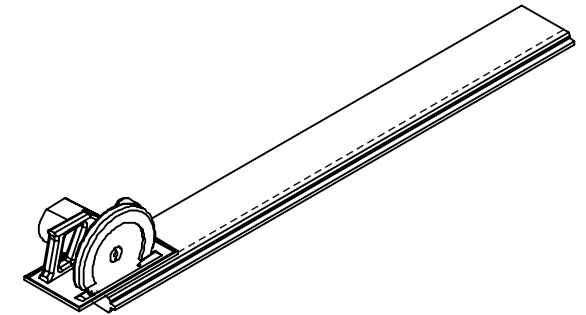

Schneiden Sie das letzte Stück auf die
richtige Größe zu und lassen Sie dabei
einen seitlichen Abstand von 2 mm.

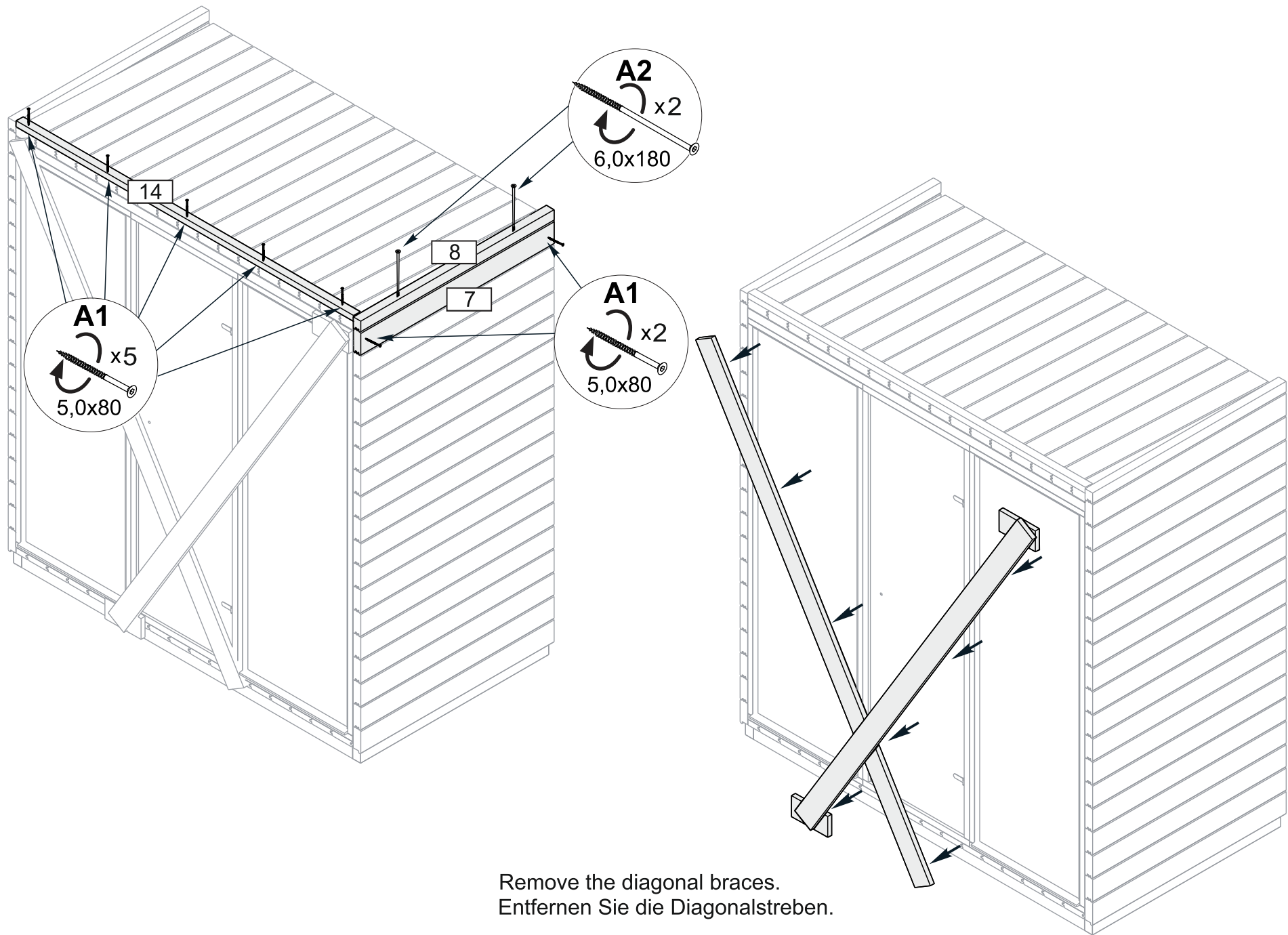

Remove the diagonal braces.
Entfernen Sie die Diagonalstreben.



Install the tape only when the wood is completely dry. ·
Bringen Sie das Klebeband erst an, wenn das Holzvollständig trocken ist.

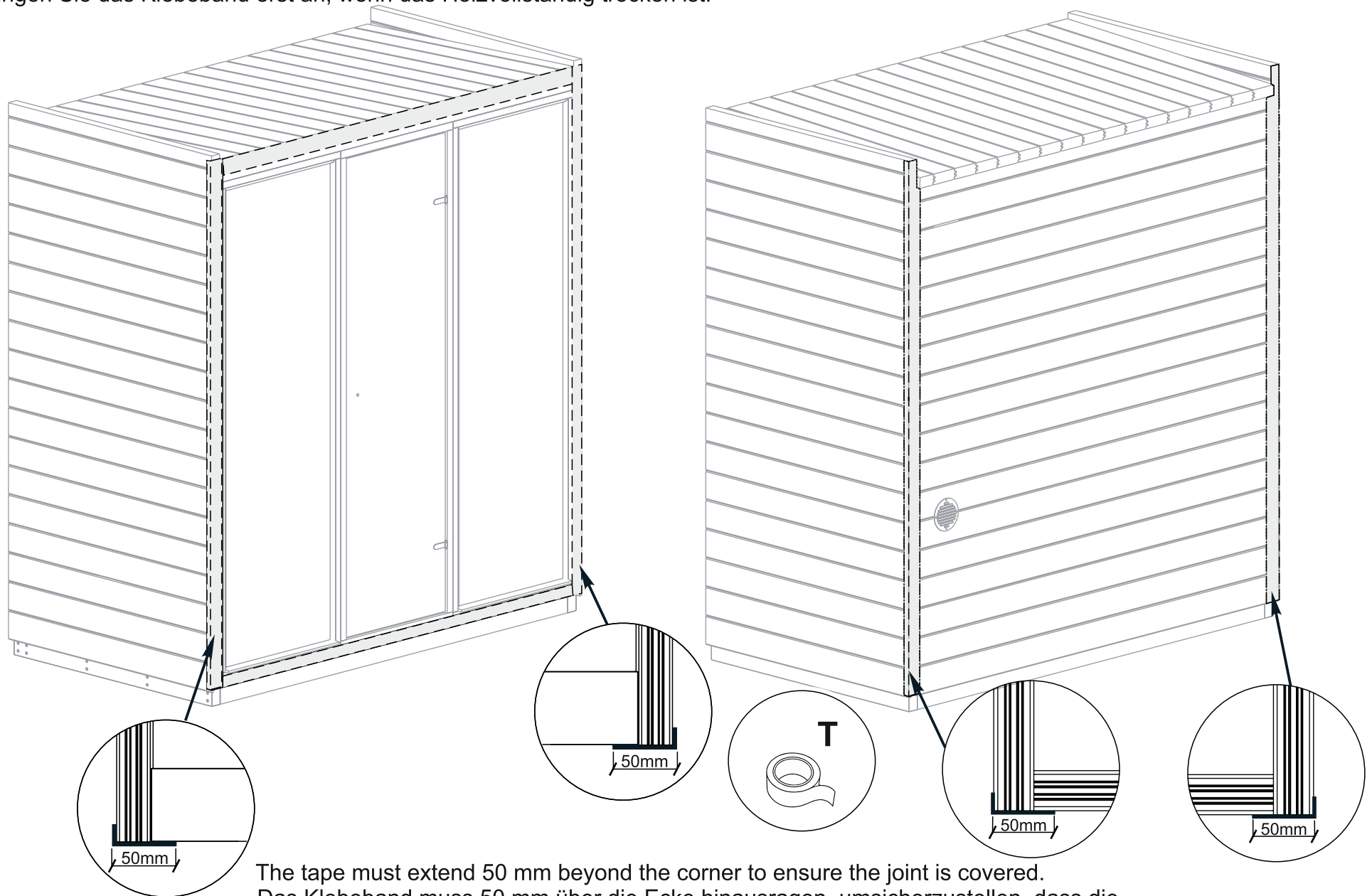

The tape must extend 50 mm beyond the corner to ensure the joint is covered.
Das Klebeband muss 50 mm über die Ecke hinausragen, um sicherzustellen, dass die Fuge abgedeckt ist.

1. Install the side boards.
Installieren Sie die Seitenbretter.

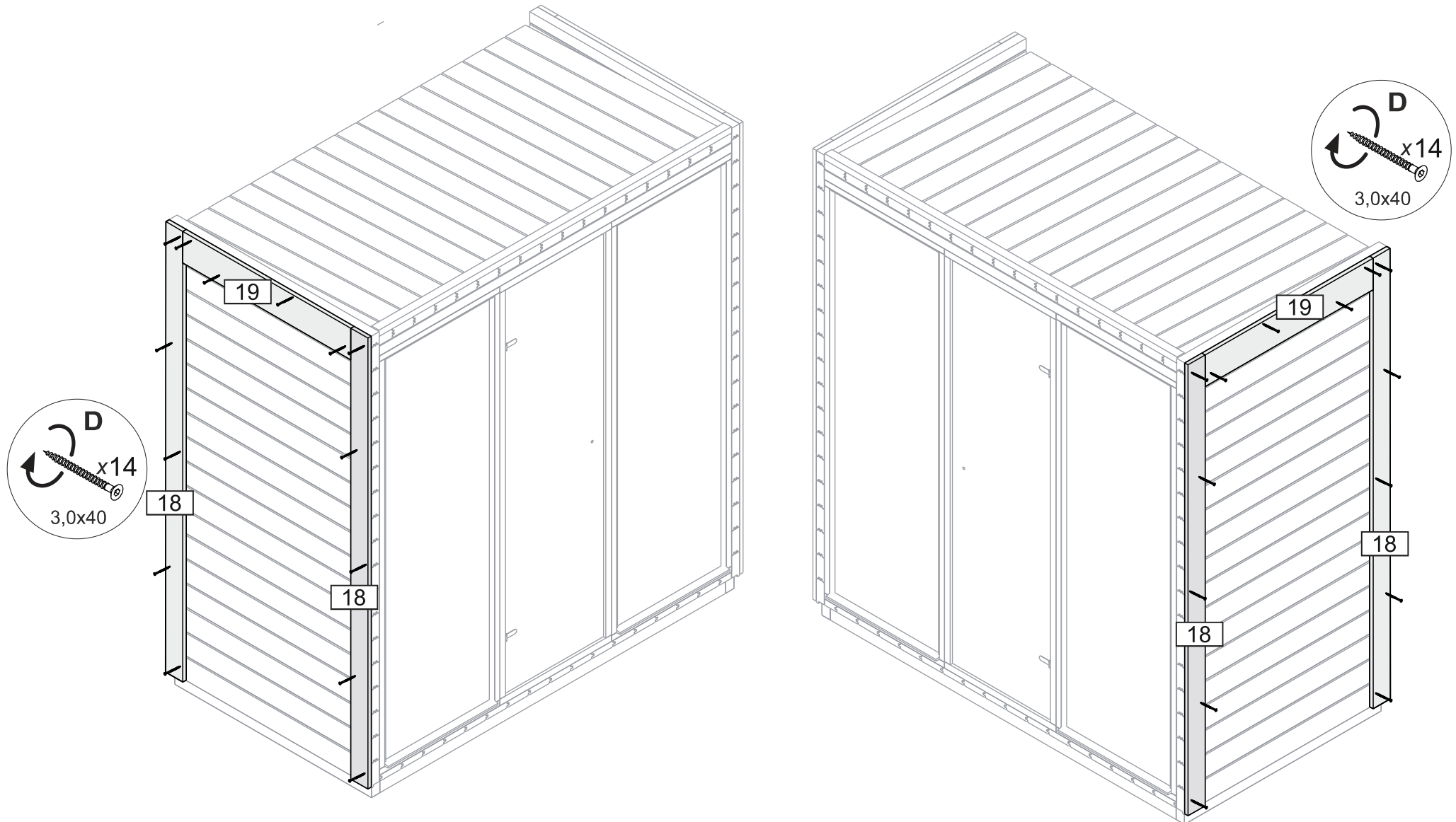

1. Install the rear and front boards.
Installieren Sie die Vorderbretter.

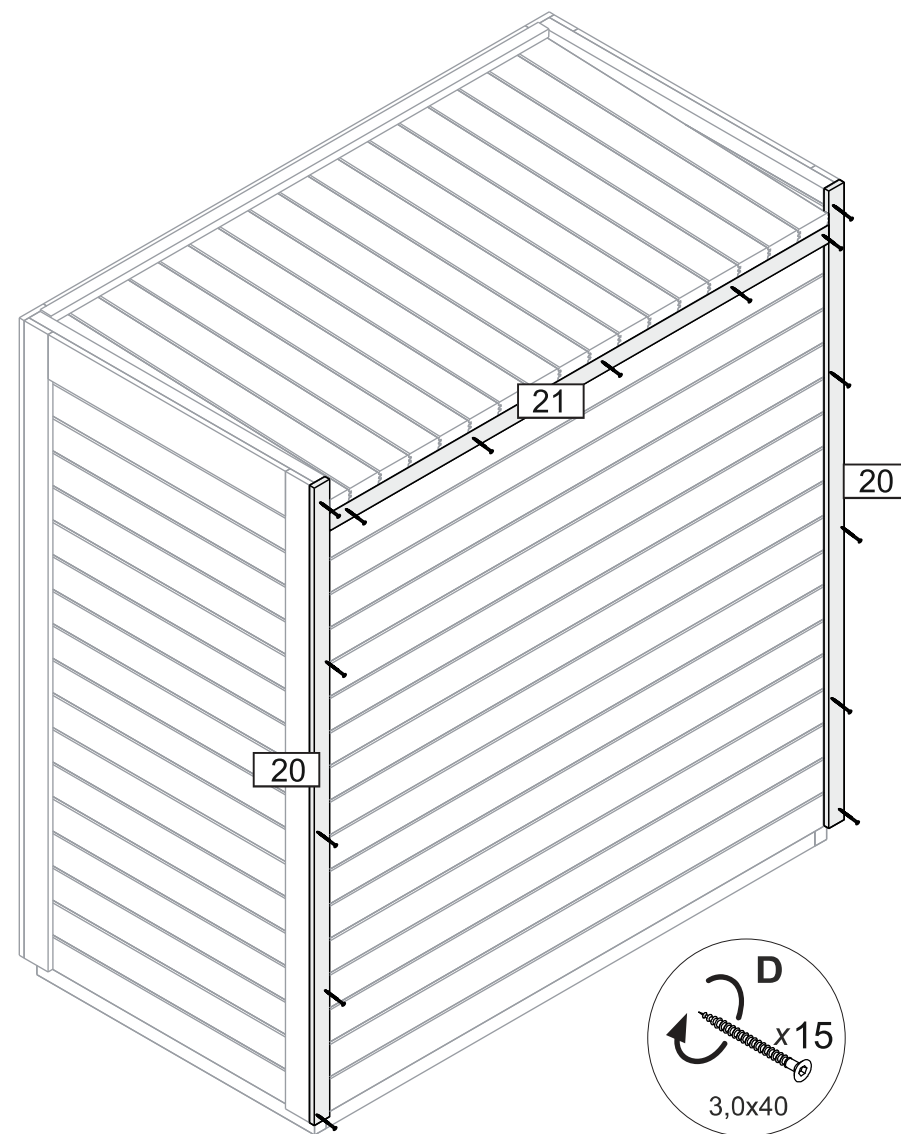
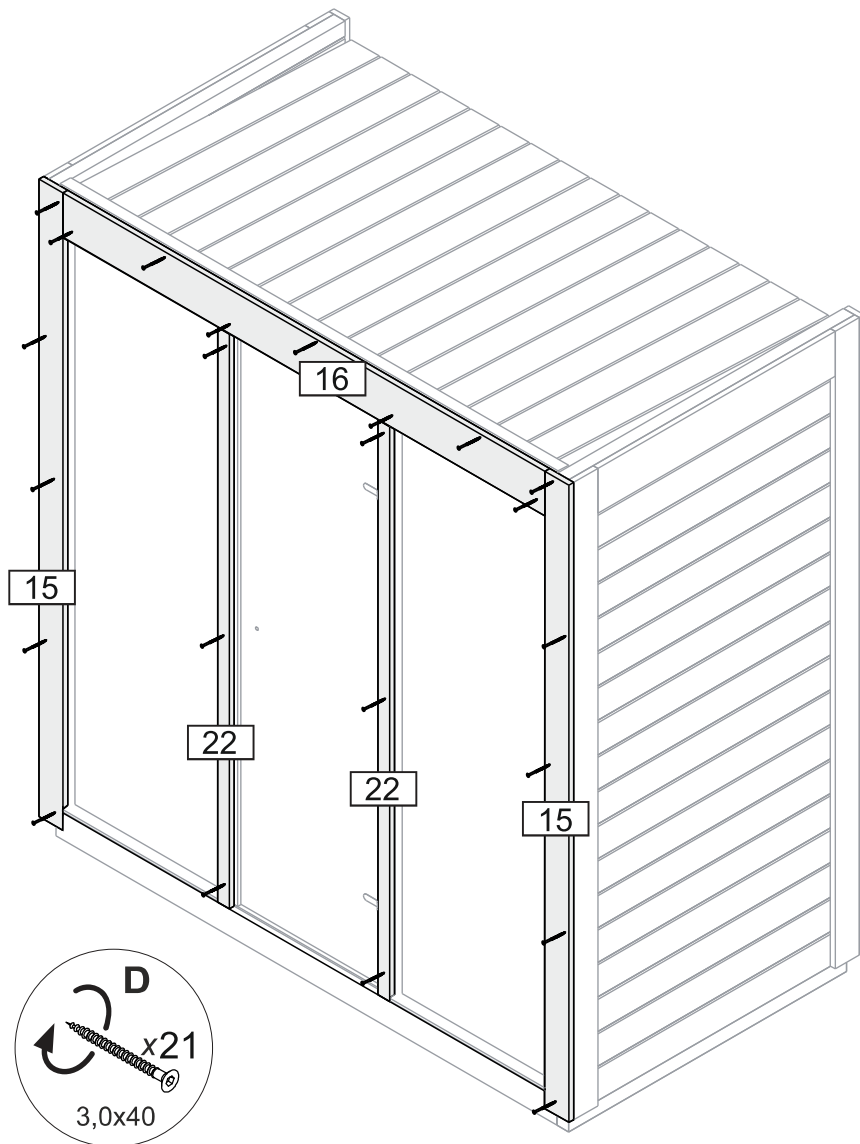

1. Install the drip edge and screws.
Installieren Sie die Tropfkante und die Schrauben.

2. Install the front boards.
Installieren Sie die Vorderbretter.

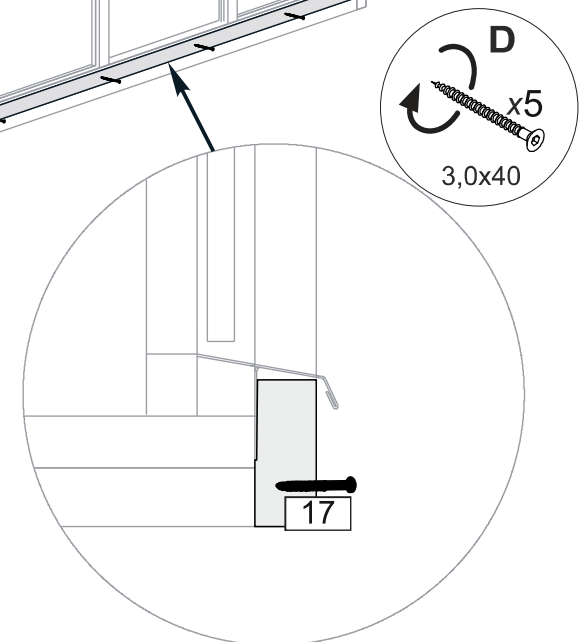
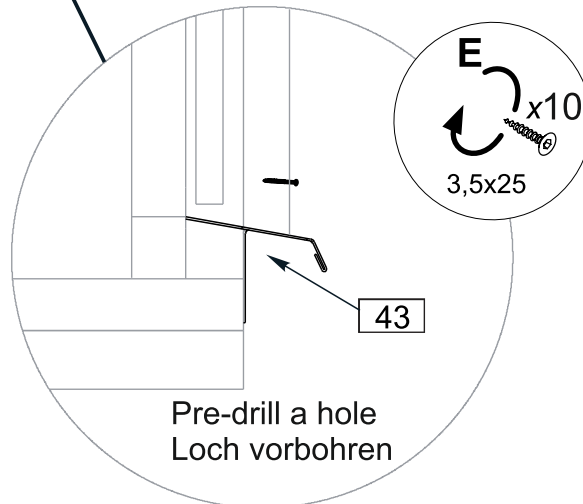
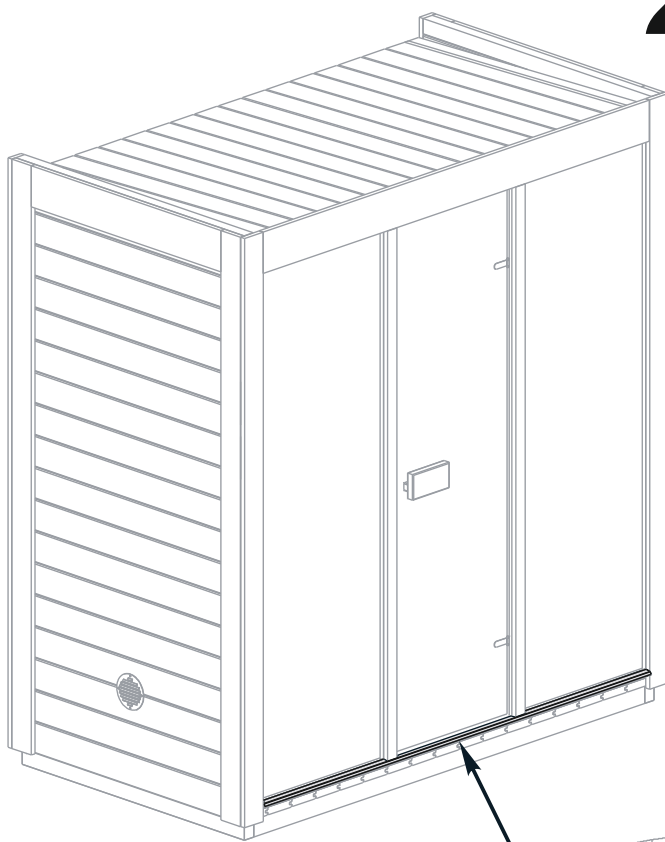

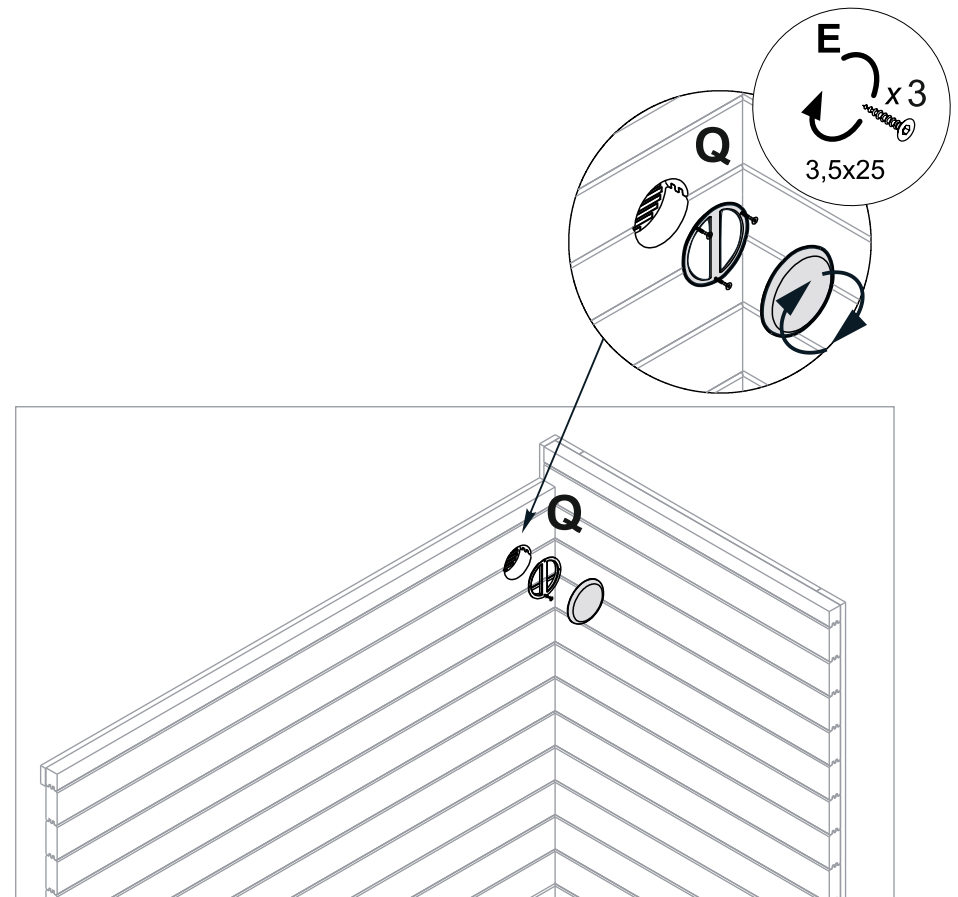
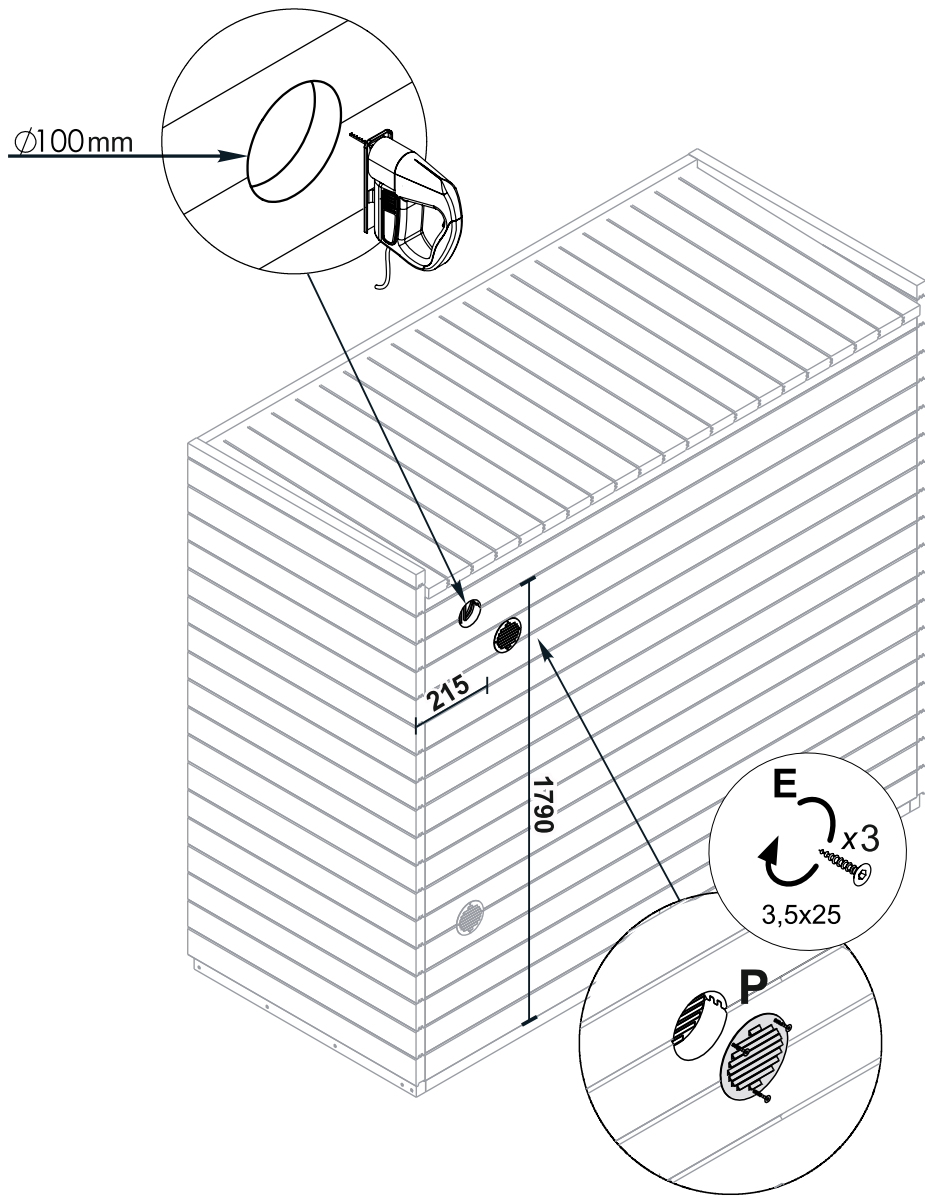

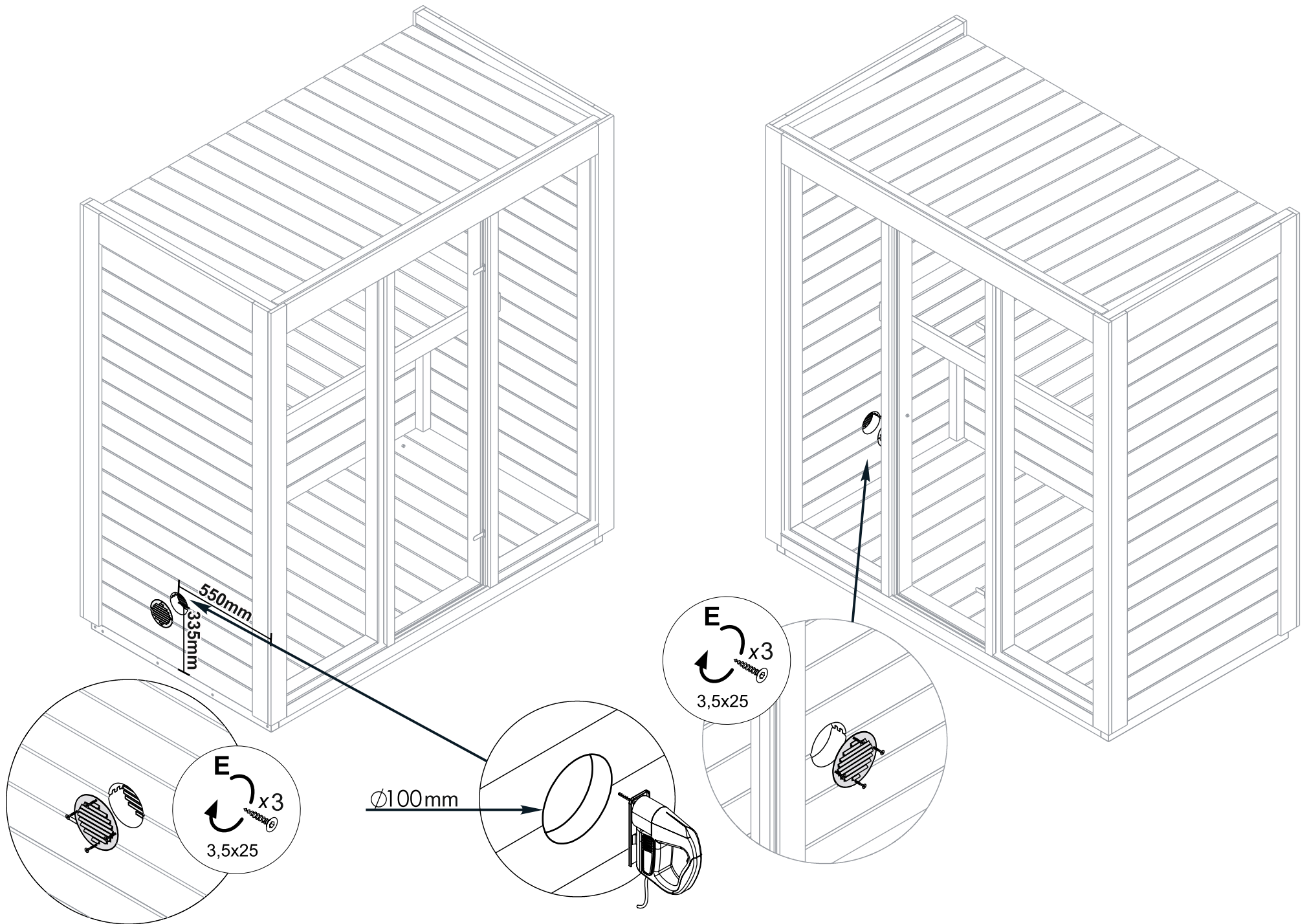

- 1.** Install the rear drip edge
■ Installieren Sie die hintere Tropfkante.

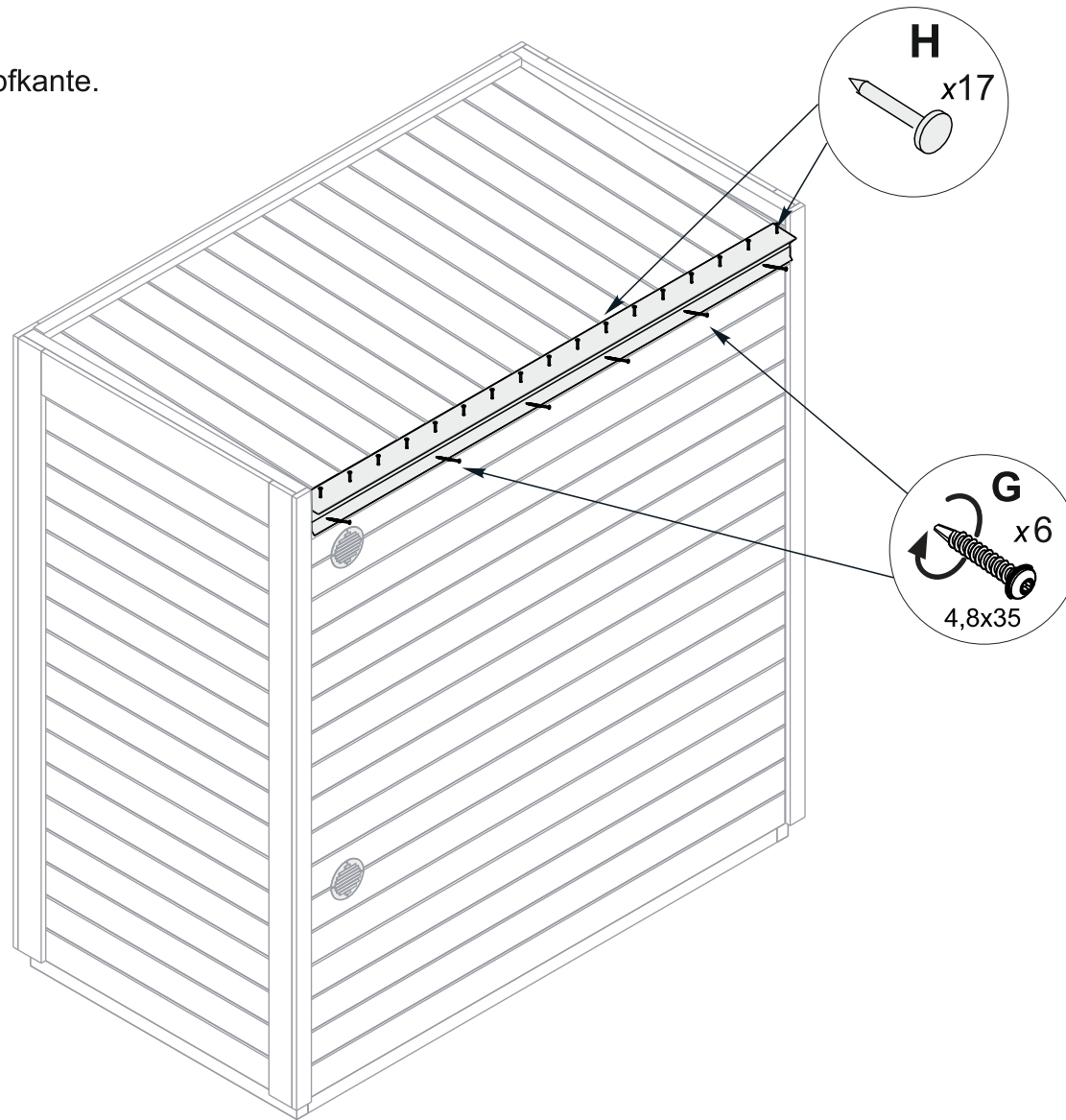

1. Use steel wool and primer by rubbing the primer onto the affected spot in smooth, circular motions to ensure proper adhesion. Allow the primer to dry completely before applying the next step.

Verwenden Sie Stahlwolle und Grundierung, indem Sie die Grundierung mit sanften, kreisenden Bewegungen auf die betroffene Stelle auftragen, um eine gute Haftung zu gewährleisten. Lassen Sie die Grundierung vollständig trocknen, bevor Sie den nächsten Schritt ausführen.

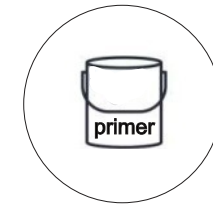
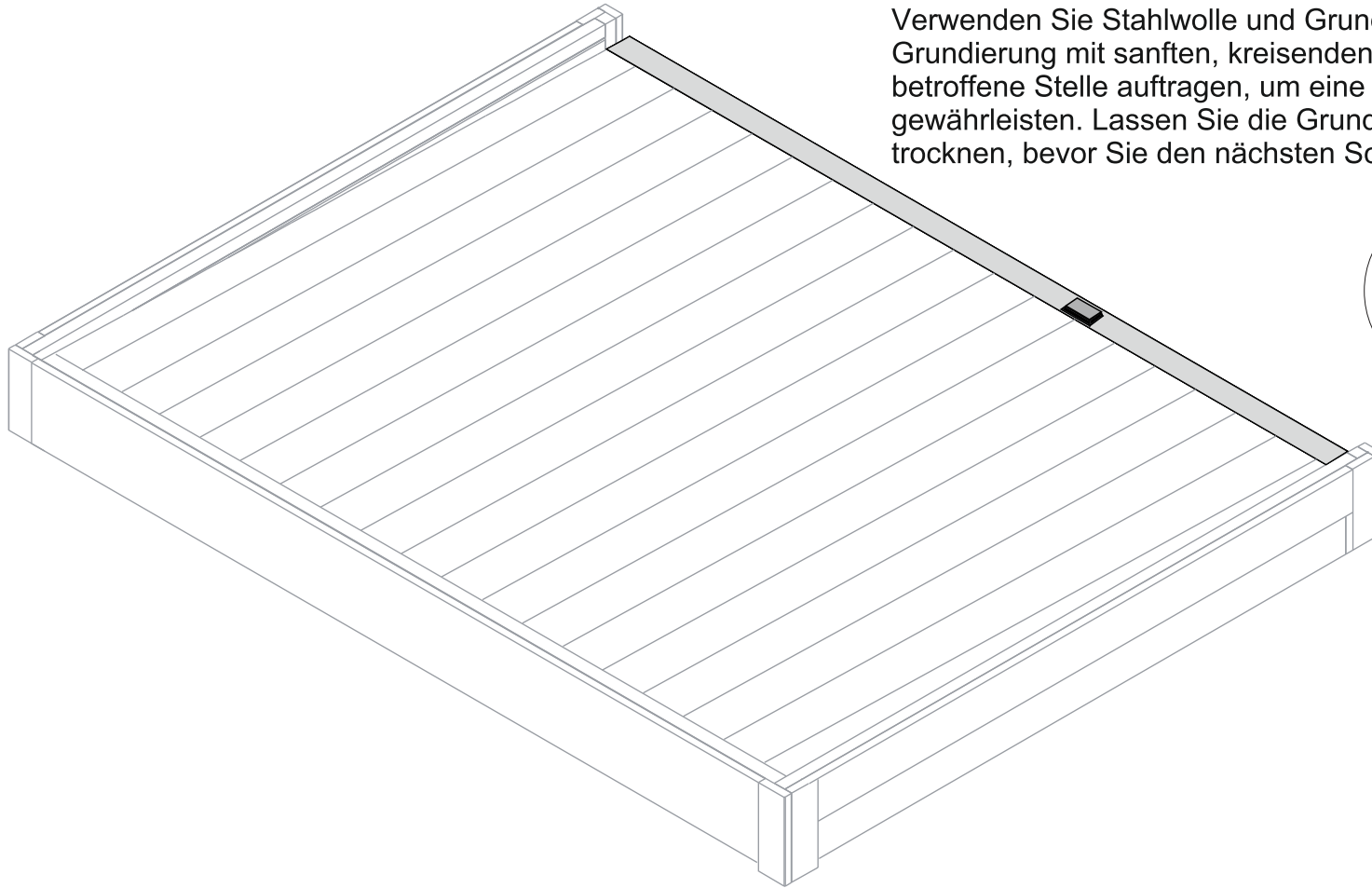



Note! The tape adhesive is strong, so please apply it carefully. Do not remove the top protective film.
Hinweis! Das Klebeband haftet stark, bringen Sie es daher vorsichtig an. Entfernen Sie die obere Schutzfolie nicht.

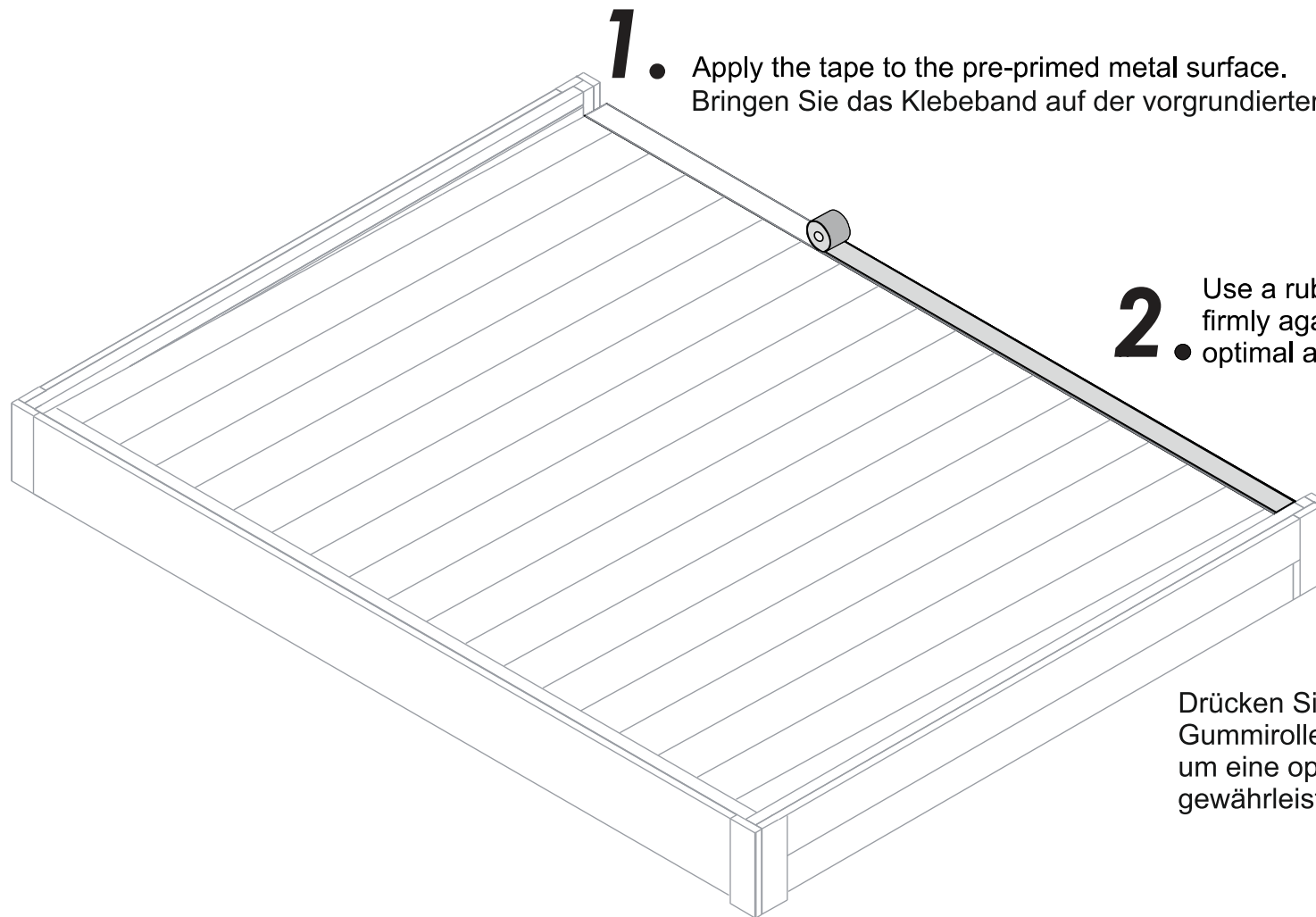

1. Apply the tape to the pre-primed metal surface.
Bringen Sie das Klebeband auf der vorgrundierten Metalloberfläche an.

2. Use a rubber roller to press the tape firmly against the surface to ensure optimal adhesion.

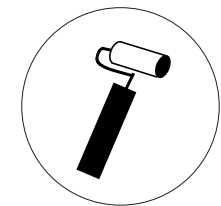

Drücken Sie das Band mit einer Gummirolle fest auf die Oberfläche, um eine optimale Haftung zu gewährleisten.

- 1.** Place the PVC roofing membrane in the center so that an equal amount of material remains on each side.
- Platzieren Sie die PVC-Dachbahn mittig, sodass auf beiden Seiten gleich viel Material übrig bleibt.

- 2.** Place the roofing membrane 10 mm from the metal edge. If needed, trim the edge of the membrane to ensure it is straight.
- Platzieren Sie die Dachbahn 10 mm vom Metallrand entfernt. Schneiden Sie die Bahnkante bei Bedarf gerade zu.

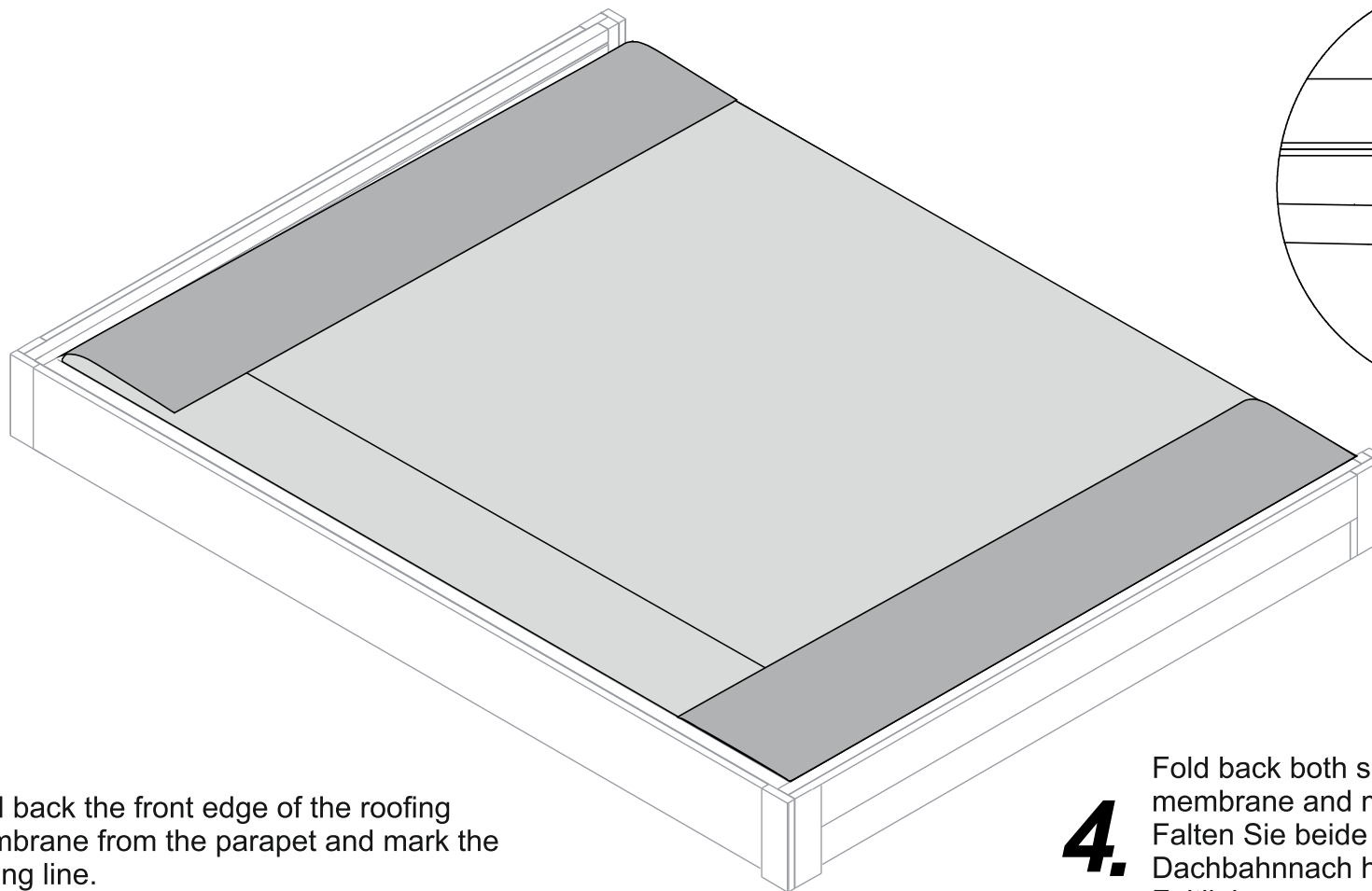

- 3.** Fold back the front edge of the roofing membrane from the parapet and mark the folding line.
- Die Vorderkante der Dachbahn von der Brüstung zurückschlagen und die Faltlinie markieren.

- 4.** Fold back both side edges of the roofing membrane and mark the folding lines.
- Falten Sie beide Seitenkanten der Dachbahn nach hinten und markieren Sie die Faltlinien.



Attention! Use only adhesive outdoors or in well-ventilated areas. Read the information sheet before using.
Achtung! Verwenden Sie den Klebstoff nur im Freien oder in gut belüfteten Räumen. Lesen Sie vor der Anwendung das Informationsblatt.

1.

Use a spray line to apply a thin, even layer of PVC adhesive to the roof.

Verwenden Sie eine Sprühlinie, um eine dünne, gleichmäßige Schicht PVC-Klebstoff auf das Dach, aufzutragen.



2.

Apply adhesive to the PVC membrane, leaving the edges and the area near the rear flashing uncovered.

Tragen Sie Klebstoff auf die PVC-Membran auf und lassen Sie die Kanten und den Bereich in der Nähe der hinteren Abdeckung unbedeckt.

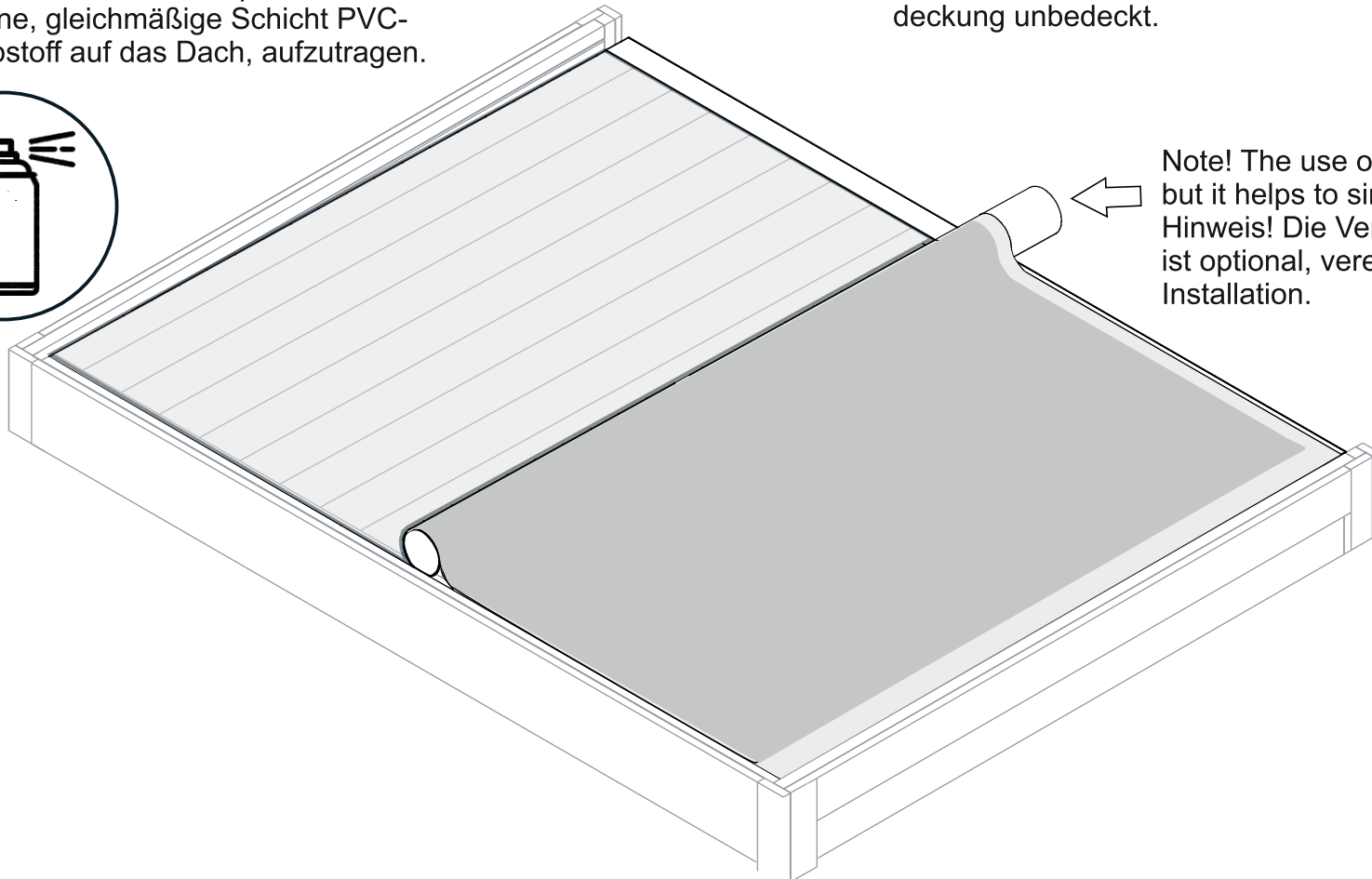

Note! The use of a PVC tube is optional, but it helps to simplify the installation.
Hinweis! Die Verwendung eines PVC-Rohrs ist optional, vereinfacht jedoch die Installation.



Scan Me
Scanne mich

- 1.** Wait about 30 minutes until the adhesive is no longer tacky. Carefully roll the membrane onto the roof, holding the tube from both sides.
• Use a brush to smooth the membrane evenly onto the roof.

Warten Sie etwa 30 Minuten, bis der Klebstoff nicht mehr klebt.
• Rollen Sie die Membran vorsichtig auf das Dach und halten Sie dabei die Röhre von beiden Seiten fest. Streichen Sie die Membran mit einer Bürste gleichmäßig auf dem Dach glatt.



Attention! Use only adhesive outdoors or in well-ventilated areas. Read the information sheet before using.
Achtung! Verwenden Sie den Klebstoff nur im Freien oder in gut belüfteten Räumen. Lesen Sie vor der Anwendung das Informationsblatt.

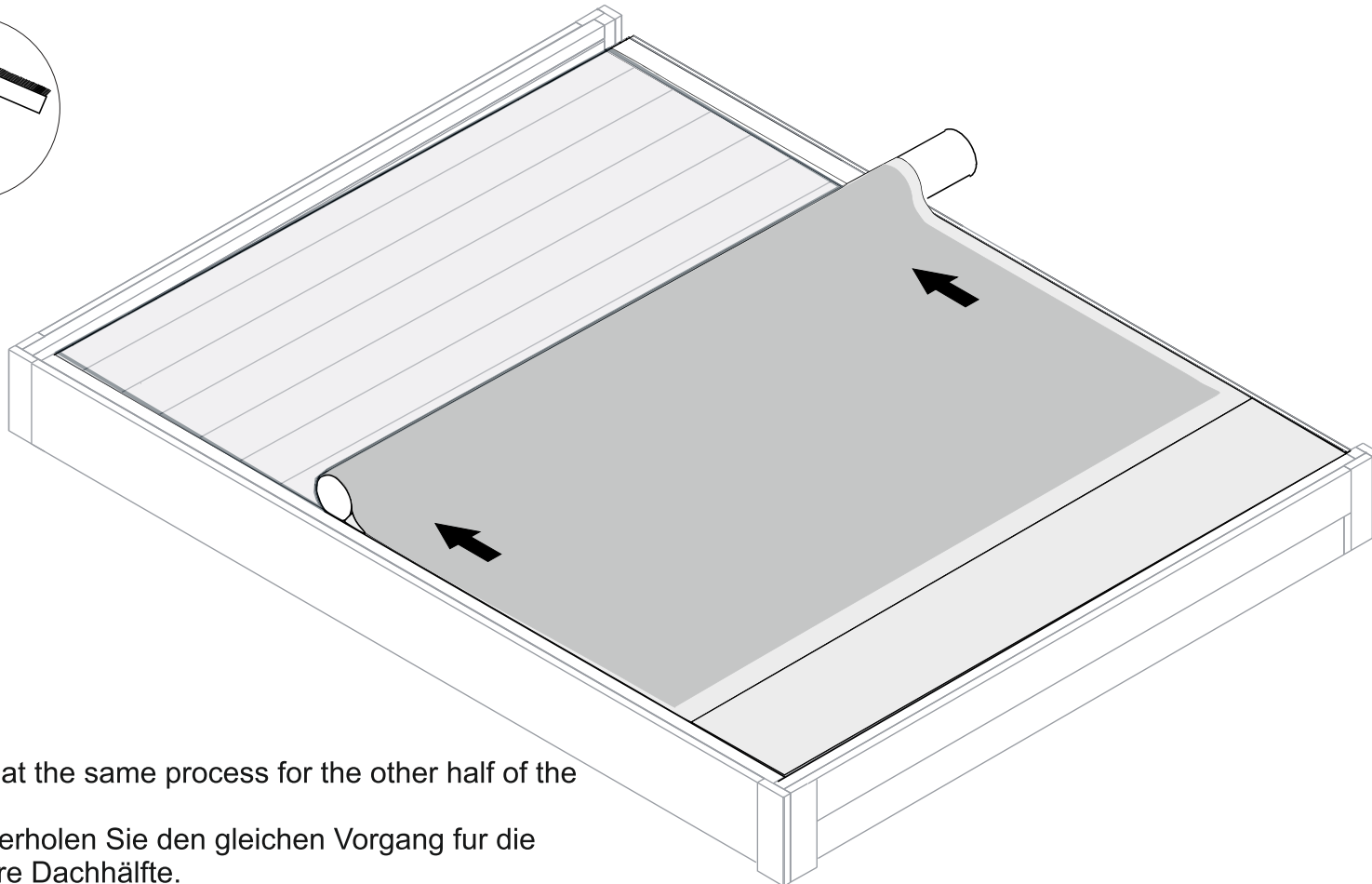
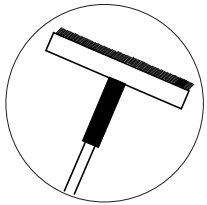

- 2.** Repeat the same process for the other half of the roof.
Wiederholen Sie den gleichen Vorgang für die andere Dachhälfte.



Scan Me
Scanne mich

- 1.** An "ear" should form at the corner. Adjust it so that it can be folded back neatly into the corner. Apply adhesive between the layers so the "ear" can be securely bonded in place.
An der Ecke sollte sich ein „Ohr“ bilden. Passen Sie es so an, dass es sauber in die Ecke zurückgeklappt werden kann. Tragen Sie zwischen den Schichten Klebstoff auf, damit das „Ohr“ sicher an Ort und Stelle haftet.

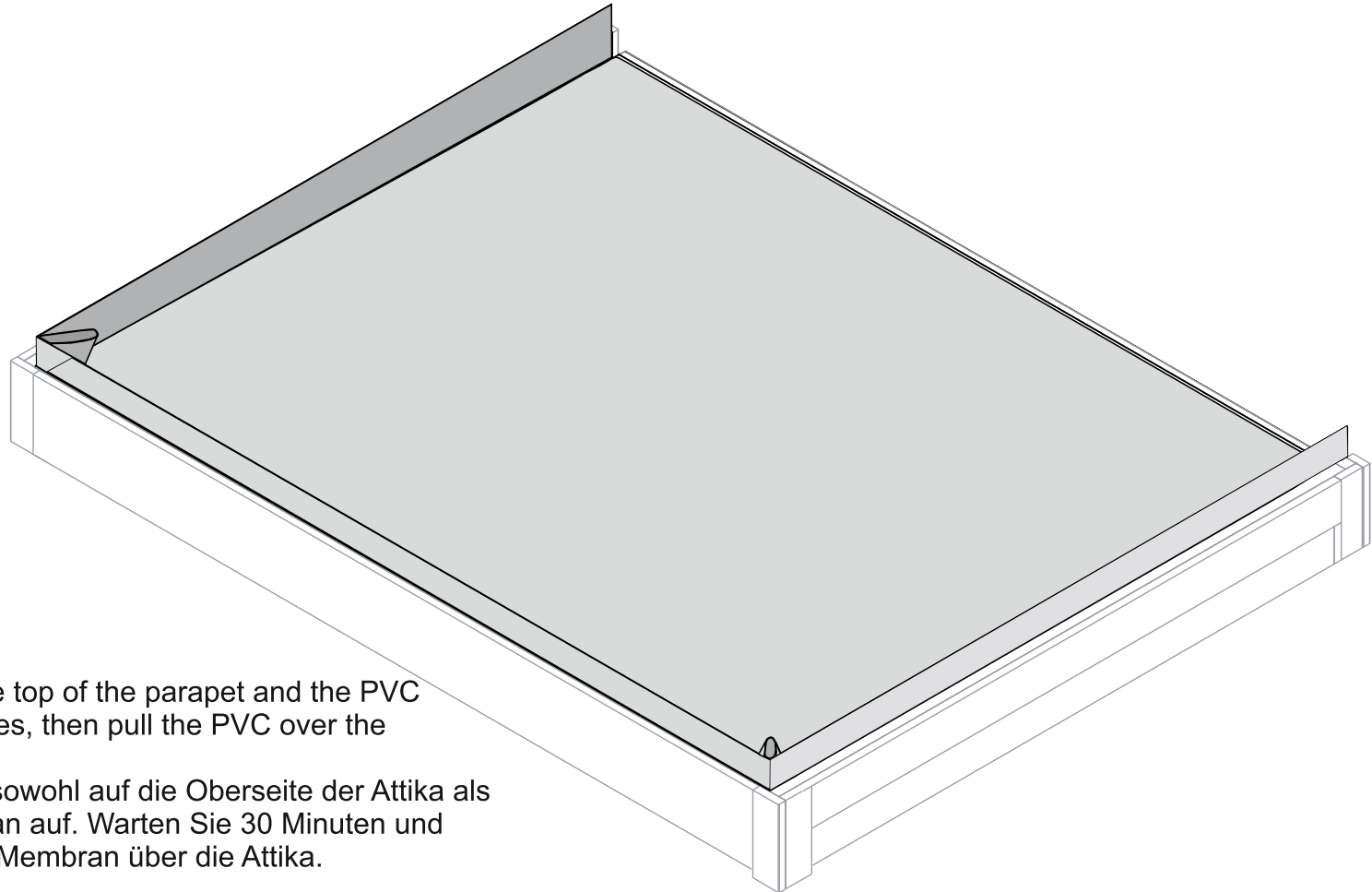
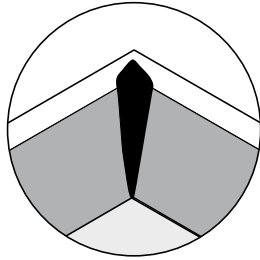

- 2.** Apply adhesive to both the top of the parapet and the PVC membrane. Wait 30 minutes, then pull the PVC over the parapet.
Tragen Sie den Klebstoff sowohl auf die Oberseite der Attika als auch auf die PVC-Membran auf. Warten Sie 30 Minuten und ziehen Sie dann die PVC-Membran über die Attika.

- 1.** Lift the PVC edge, apply primer with steel wool, let it dry. Remove the tape backing, and press the PVC firmly onto the tape, and use a roller to ensure better adhesion.
PVC-Kante anheben, Grundierung mit Stahlwolle auftragen, trocknen lassen, Klebebandrückseite entfernen und PVC fest auf das Klebeband drücken, mit einer Rolle für bessere Haftung sorgen.

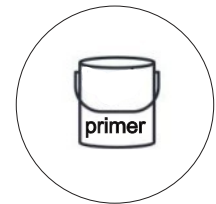
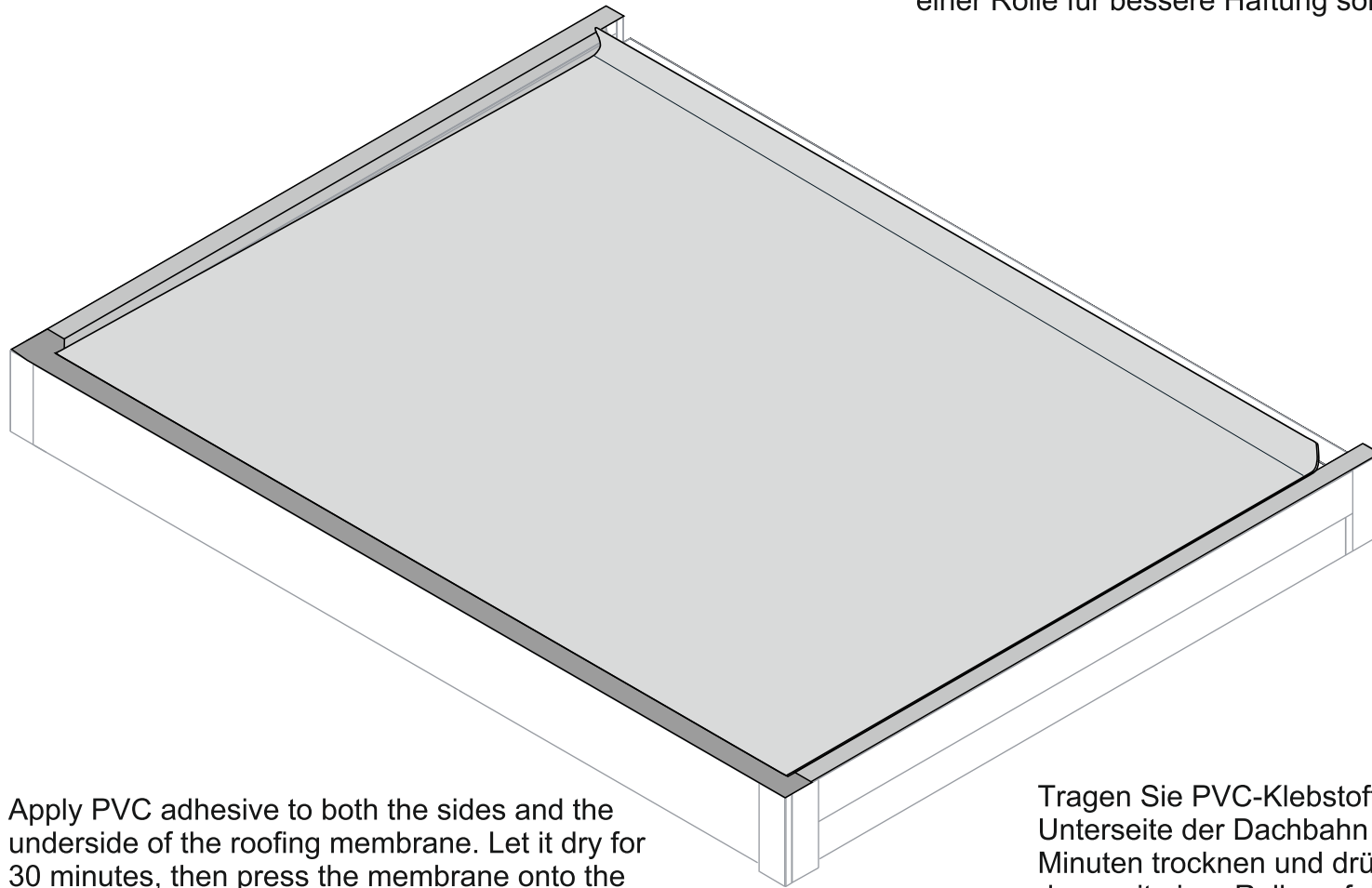

- 2.** Apply PVC adhesive to both the sides and the underside of the roofing membrane. Let it dry for 30 minutes, then press the membrane onto the roof using a roller. Do the same with the front edge as you did with the sides, but do not glue the corner or the top in place yet.

Tragen Sie PVC-Klebstoff auf beide Seiten und die Unterseite der Dachbahn auf. Lassen Sie ihn 30 Minuten trocknen und drücken Sie die Dachbahn dann mit einer Rolle auf das Dach. Gehen Sie mit der Vorderkante genauso vor wie mit den Seiten, kleben Sie aber die Ecke oder die Oberseite noch nicht fest.

- 1.** Apply adhesive to both the top of the parapet and the PVC membrane. Wait 30 minutes, then pull the PVC over the parapet.
Tragen Sie Klebstoff sowohl auf die Oberseite der Brüstung als auch auf die PVC-Membran auf. Warten Sie 30 Minuten und ziehen Sie dann die PVC-Membran über die Brüstung.

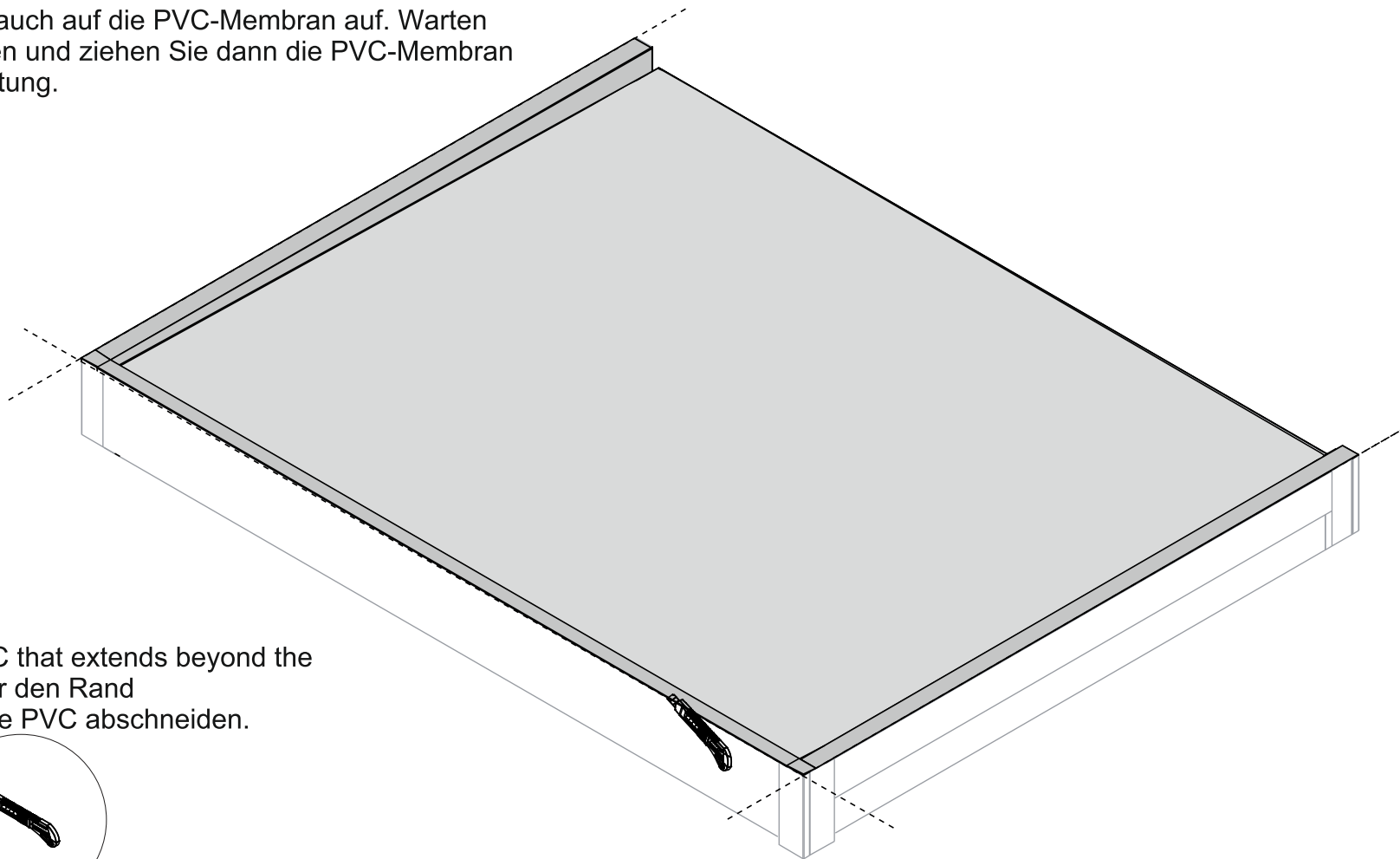

- 2.** Cut off the PVC that extends beyond the edge. Das über den Rand hinausstehende PVC abschneiden.

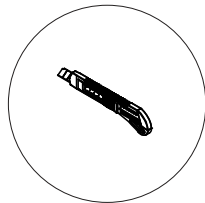

Cut end faces forward.
Geschnittenes Ende nach vorne richten.

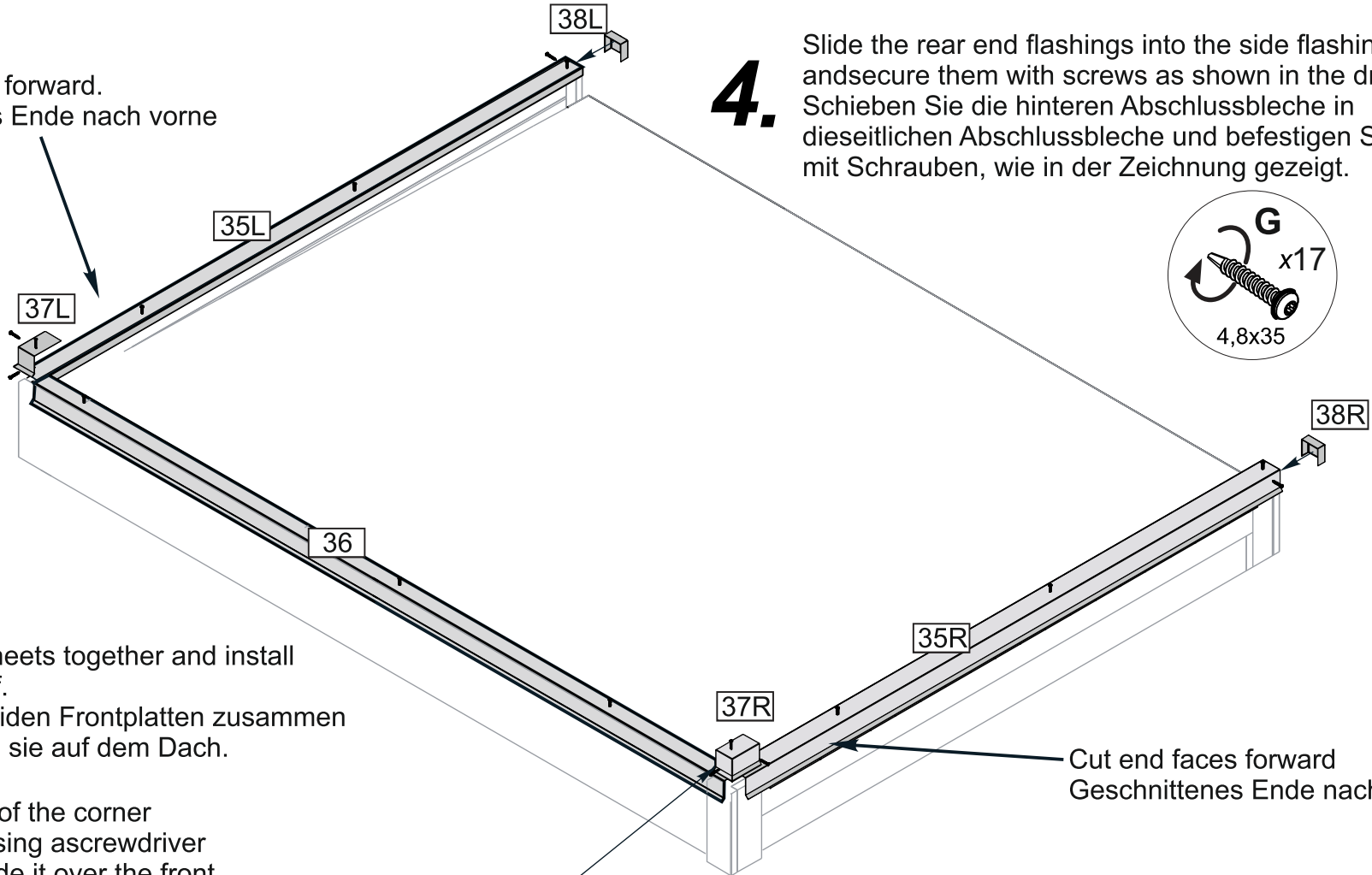

4.

Slide the rear end flashings into the side flashings and secure them with screws as shown in the drawing. Schieben Sie die hinteren Abschlussbleche in dieseitlichen Abschlussbleche und befestigen Sie sie mit Schrauben, wie in der Zeichnung gezeigt.

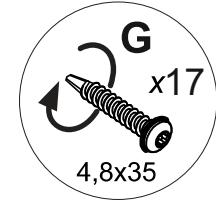

1. Fit the two front sheets together and install them onto the roof.
Passen Sie die beiden Frontplatten zusammen und montieren Sie sie auf dem Dach.

2. Bend out the tabs of the corner flashing halfway using a screwdriver so that you can slide it over the front sheet. Also bend the tabs for the side flashing.
Biegen Sie die Laschen der Eckverkleidung mit einem Schraubendreher zur Hälfte heraus, damit Sie sie über das vordere Blech schieben können. Biegen Sie auch die Laschen der Seitenverkleidung um.

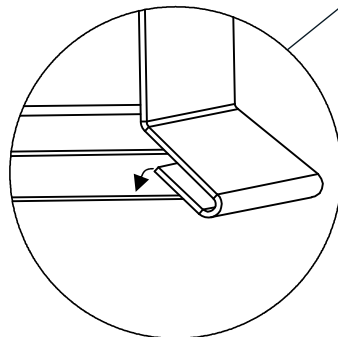

Cut end faces forward
Geschnittenes Ende nach vorne

3.

Install the side flashings with the cut edge facing the front. The back edge must be aligned with the board, if necessary trim the inner corner.
Montieren Sie die Seitenbleche mit der Schnittkante nach vorne. Die Hinterkante muss mit der Platte ausgerichtet sein. Falls erforderlich, schneiden Sie die Innenecke ab.

5.

Bend the tabs back using pliers with padding, if needed.
Biegen Sie die Laschen bei Bedarf mit einer Zange und Polsterung zurück.

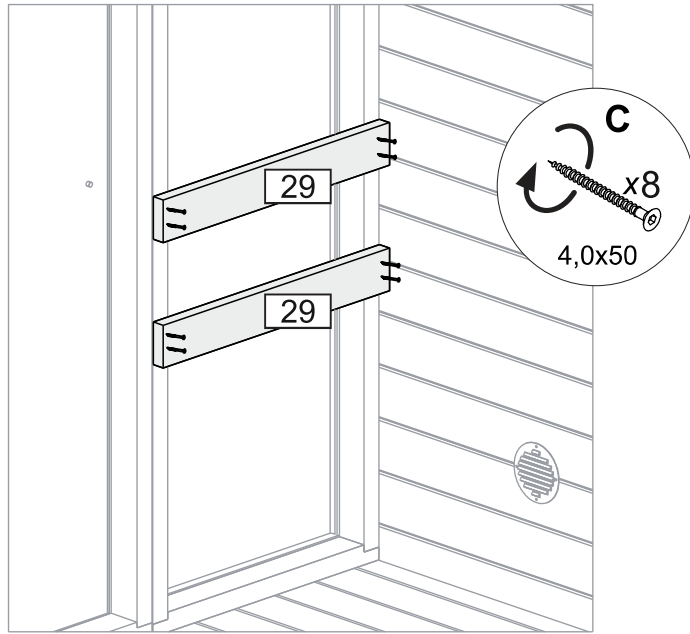

1 Install the sauna heater guard.
 ■ Installieren Sie den Ofenschutz.

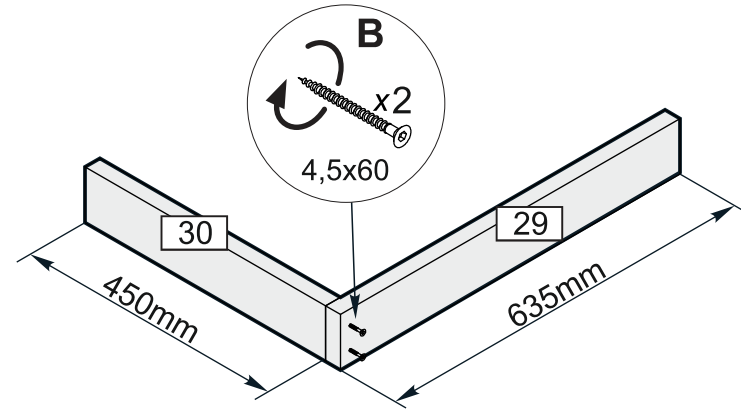

The height of the protective barrier depends on the stove. Die Höhe des Ofenschutzgitters hängt vom Ofen ab

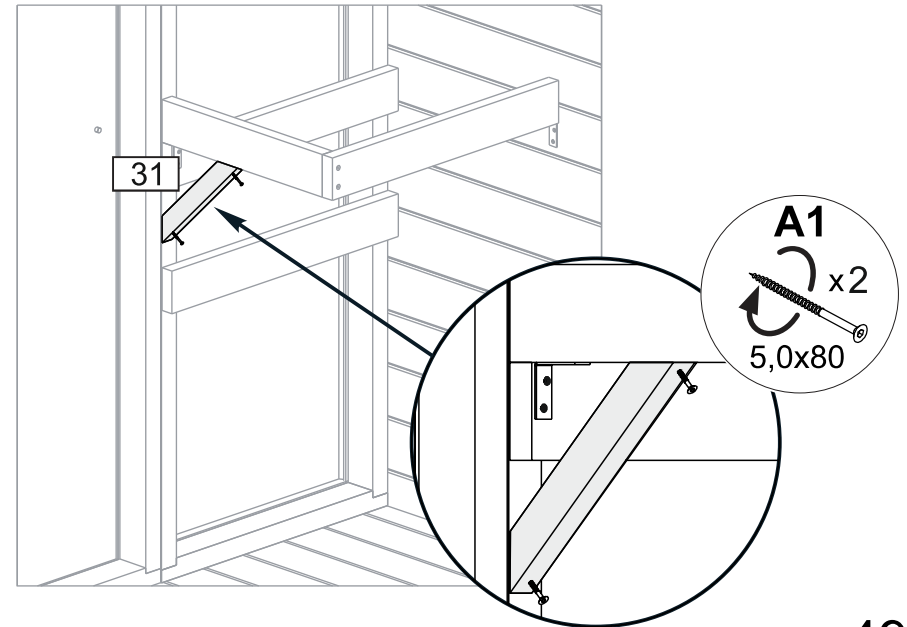
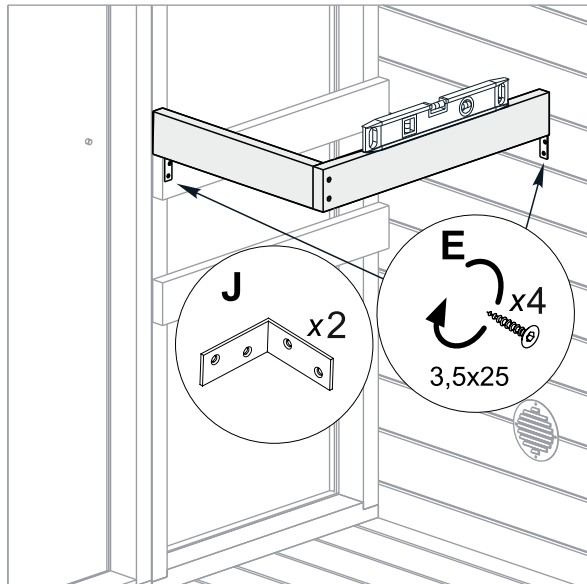

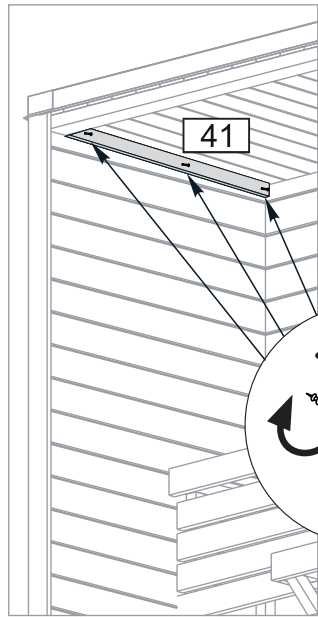

1. Install the inside trim pieces.
Installieren Sie die Innenleisten.

