

Small Head Auto Tip Dresser **CDK-SG**



Feature

1. Simultaneous dressing the upper and lower electrodes enables to reduce dressing time and be always alignment of the face after dress.
2. Balancer unit is a standard requirement, enables to reduce the load on the welding gun and the dresser.
3. Dresser with built-in rotation confirmation function by proximity sensor(Option).
4. Splash proof construction for terminal box.
5. High torque, high-speed rotation (1 sec. dressing).
6. KTW cutter dresses upper and lower electrode simultaneously ensuring tip face alignment and its life span is long.
7. Correspond to international safety standard, CCC & CE.
8. Correspond to gun with small throat depth (more than 27mm).

※ Please contact our sales for special requirement or other products.

Cutter, Holder

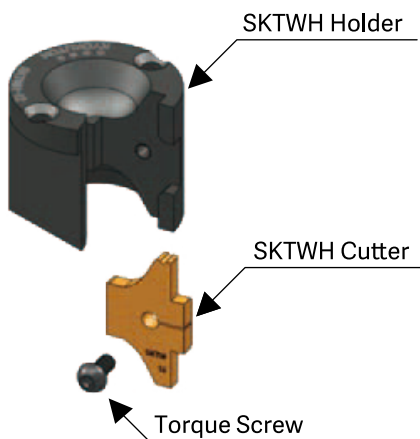

Magnified View

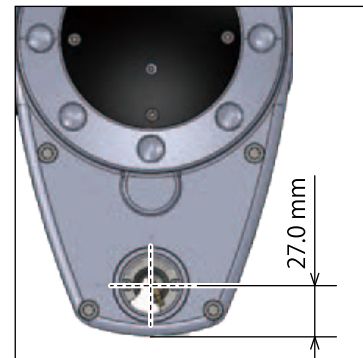

Specification

Model	CDK-SG			CDK-SG-400				CDK-SG-480		
	200	220	380	400	415	400	440	460	480	
Power AC(V)	200	220	380	400	415	400	440	460	480	
Frequency(Hz)	50	60	50	50	50	60	60	60	60	
Current(A)	4.6	4.4	4.2	2.4	2.3	2.3	2.2	2.1	2.0	2.0
Revolution(RPM)	228	273	276	225	228	230	273	276	281	283
Torque(N · m)	34.4	28.7	28.7	38.3	37.7	37.5	31.5	31.1	30.6	30.4
Power(W)	1000									
Rated Time	Continuous use 5 minutes									
Weight(kg)	17.8									

※ Specification and design are to be changed without notice for improvement.