

# FERROVAC

ULTRA HIGH VACUUM TECHNOLOGY

## Boomerax Z Stage Series

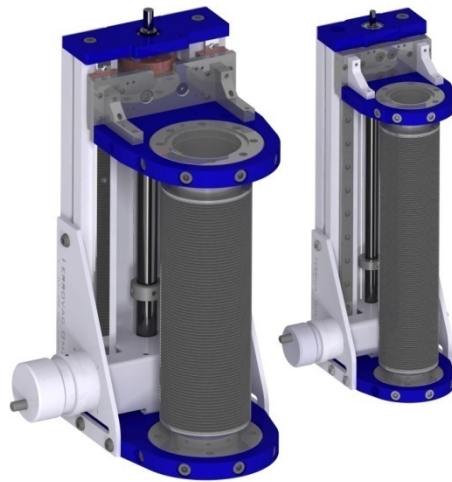

### Operating Instructions

---

*65822 Rev B [April, 2026]*

---

Ferrovac AG  
Thurgauerstrasse 72  
CH-8050 Zürich

Phone +41 44 273 16 38  
sales@ferrovac.com  
[www.ferrovac.com](http://www.ferrovac.com)

**Important!**

It is the sole responsibility of all users to carefully read the operating instructions and keep them safe. Read and follow all safety instructions carefully before using the product described in this document. Ferrovac AG declines any and all responsibility and liability for any damage/injuries resulting from incorrect use/adjusting/controlling or programming of the product.

**Warranty**

Ferrovac AG warrants this product to be free of defects in material and workmanship for a period of 24 months from the date of shipment. In case of proof of any defective parts in the product, we will at our option, either repair the product or replace it.

**Warranty limitations**

The warranty for this product does not apply to defects resulting from the following:

- Non-observance of operational- and safety instructions
- Natural wear of components
- Consumables
- Modifications to our products without our written consent
- Misuse of any product or part of the product

This warranty stands in place of all other warranties, implied or expressed, including any implied warranty of implied merchantability or fitness for a particular use. The remedies provided herein are buyer's sole and exclusive remedies.

Neither the company Ferrovac AG nor any of its employees shall be liable for any direct, indirect, incidental, consequential or special damages arising out of the use of its products, even if the company Ferrovac AG has been advised in advance of the possibility of such damages. Such excluded damages shall include but are not limited to: Costs of removal and installation, losses sustained as the result of injury to any person, or damage to property.

**Copyright**

Copyright 2019, Ferrovac AG. All rights reserved. All information in this document is the sole property of Ferrovac AG and is protected by Swiss copyright laws and international conventions. Ferrovac AG grants the right for reproduction for the purchasers own use. No part of this manual may be reproduced or transmitted by any third party in any form or by any means and for any purpose without the written permission of Ferrovac AG.

1	General Information.....	4
1.1	Designated Use.....	4
2	Terms and Symbols.....	5
3	General Safety Information.....	5
4	About.....	7
4.1	Dimensions.....	7
4.2	Product Configuration List.....	8
4.3	Specifications.....	9
5	Installation of the Stage.....	10
5.1	Unpacking and Installation.....	10
6	Operation.....	11
7	Maintenance.....	11
7.1	Venting and pumpdown.....	11
7.2	Bake-out.....	12
7.3	After Bake-out / During Normal Operation.....	12
8	Options and Upgrades.....	13
8.1	Stepper Motor Kit.....	13
8.1.1	Motor Kit MOTN17T0.7-XXXX.....	14
8.1.2	Motor Kit MOTN24T3-XXXX.....	15
8.1.3	Motor Kit MOTN24T3.6-XXXX.....	16
8.2	Limit/Position Switch.....	17
8.2.1	Limit Switch Adjustment.....	17
8.3	Weight Support.....	18
8.4	Linear Absolute Optical Encoder Kit for X-Translator.....	19
8.4.1	Incremental Encoder: NOE2.....	19
8.4.2	Absolute encoder: LAK.....	20
9	Additional information.....	20
9.1	Return of defective items.....	20
9.2	Downloads.....	20

## 1 General Information

This manual covers all important information about installation, commissioning and operation of your Boomerax Z Stage. It also provides important safety information, maintenance- and fault finding procedures.

The product described was manufactured in accordance with the applicable national standards and guidelines. The information in this document represents the state of the product at the date of print. Technical changes may be made without notice. Ferrovac AG makes no warranties or representations with respect to accuracy or completeness of the contents of this publication. Figures and photos are not binding. The product names used are for identification purposes and may be trademarks of their respective companies.

### 1.1 Designated Use

The product described in this document may only be used for its designated application. Designated use of the product is exclusively given if the following rules are obeyed:

- Product is used with original cable sets supplied by Ferrovac which are explicitly specified for the use with the product described in this publication
- In an indoor research laboratory environment or an industrial production or processing facility
- By personnel qualified for operation of delicate scientific equipment
- In accordance with all related manuals.









#### **Important!**

Carefully read all safety instructions and all relevant manuals before using the product and any related equipment!

**Non-designated use is given if the following is true:**

- Product is used with other equipment not explicitly acknowledged by Ferrovac in writing.
- Product is used outdoors or at ambient conditions exceeding the values given in the product specification
- Product is used by non-qualified persons
- Operation of the product in disregard of the safety instructions
- Operation of the product with disabled, modified, removed or damaged safety equipment and devices.

## 2 Terms and Symbols

Symbol	Term	Meaning
	<b>Danger!</b>	Risk of mortal danger when not observed
	<b>Warning!</b>	Risk of severe injury or danger to life when not observed
	<b>Caution!</b>	Slight risk of injury or damage to product when not observed
	<b>High voltage!</b>	Potentially lethal voltages are present
	<b>Cryogenic Substances!</b>	Potential cold burn hazard if safety precautions are not followed
	<b>Important!</b>	Important information for proper operation of the product
	<b>Info, hint!</b>	Useful hints, tips and clues

## 3 General Safety Information

Read the safety instructions very carefully. All safety precautions must be strictly observed at all times before using the product described in this manual and any associated instrumentation.

**Study this document** to learn how to operate your product properly. Keep this instruction manual in a save place close to the described product and inform all other users of the product. Always include this manual when handing the product over to third party persons.

**Responsible body** is the individual or group of persons that are responsible for the proper use and maintenance of the product, ensuring that the product is operated within its specifications and operating limits. The responsible body must ensure that users of the product are adequately trained.

**Operators** are using the product for its intended purpose. Users must be trained in electrical safety, handling of cryogenic liquids and adequate use of the instrument. They must be protected from electric shock and contact with potentially dangerous situations.

**Maintenance Personnel** perform routine tasks on the product to keep it in proper operating conditions i.e. setting up the line voltage or replacing consumables. Maintenance procedures are described in this manual and must be followed at all times.

**Service Personnel** are trained to work on live circuits and to work cryogenic liquids as well as perform fault finding measurements and repair work to the product. Only fully trained service personnel qualified to handle potentially lethal voltages may perform servicing and repair.

**Shock hazard:** The American National Standards Institute states that a shock hazard exists when voltage levels are greater than 30 V RMS, 42.2 V peak or 60 VDC. A good safety practice is to assume that hazardous voltages are present in any unknown circuitry.



### Warning!

- Always observe and strictly follow the safety notes and regulations given in this document
- Never operate the device outside its dedicated environment.
- DO NOT OPEN the device unless you fulfill the requirements of a fully trained service personnel and you are familiar with ultra-high vacuum products



### Important! Ambient conditions and environment:

This product is only to be used indoors, in locations meeting the following requirements:

- Room temperature lies between 5°C/41°F and 40°C/104°F
- Humidity up to maximum of 80%
- Altitudes up to 2000m
- Pollution Degree 2 environments

## 4 About

The Boomerax Z Stage was specifically designed to provide high precision Z manipulation and may be applied in high and ultra-high vacuum assemblies. The Boomerax Z Stage offers exceptionally smooth 1-axis adjustment. Motorized actuation is generally available optionally.

The Boomerax Z Series is available in 2 different bore sizes (MZ40, MZ63). The linear travel and mounting flange sizes depend on the bore. To provide an overview of the different combination possibilities, please refer to the following technical drawing and product configuration list.

### 4.1 Dimensions

Technical drawing of Automatic Boomerax Z Stage Series. All measures are in mm.

#### BOOMERAX MZ40:

- Bore Size: 38mm
- Max Travel: 1000mm

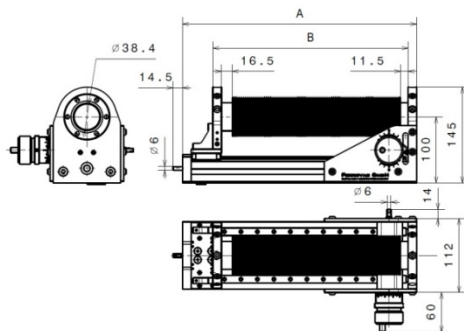

#### BOOMERAX MZ63:

- Bore Size: 65mm
- Max Travel: 1250mm

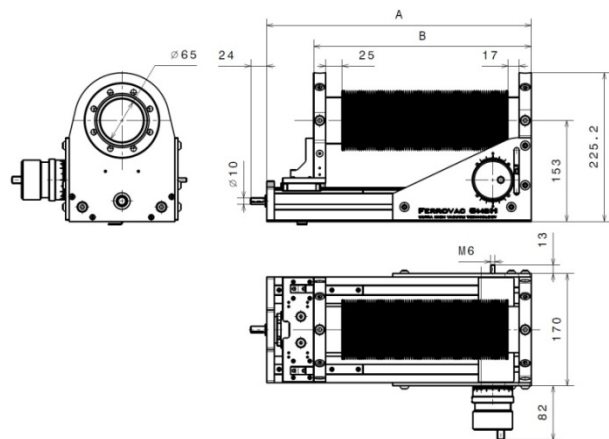

## 4.2 Product Configuration List

With respect to the 2 different Boomerax nominal sizes, following configurations are possible:

Base Flange	Travel Flange	Max Z Travel [mm]	Bore Size [mm]	A [mm]	B [mm]	No. of Bellow Supports	Product Key
DN40CF (2.75" OD)	DN40CF (2.75" OD)	100	38	231	186.5	0	MZ40CF40CF40-0100
		200		355	309	0	MZ40CF40CF40-0200
		300		-	-	1	MZ40CF40CF40-0300
		500		-	-	2	MZ40CF40CF40-0500
		750		-	-	3	MZ40CF40CF40-0750
		1000		-	-	4	MZ40CF40CF40-1000
DN63CF (2.75" OD)	DN63CF (2.75" OD)	100	65	280	-	0	MZ63CF63CF63-0100
		200		401	329.5	0	MZ63CF63CF63-0200
		300		522	-	0	MZ63CF63CF63-0300
		500		-	-	1	MZ63CF63CF63-0500
		750		-	-	1	MZ63CF63CF63-0750
		1000		1362	-	2	MZ63CF63CF63-1000
		1250		1673	1641	3	MZ63CF63CF63-1250

### 4.3 Specifications

- Pressure Range: 1E-11 to 1000 mbar
- He Leak Rate:  $< 5E-10 \text{ mbar} \times \text{l} \times \text{s}^{-1}$
- Bake-out Temperature: 200 °C (Only bake bellows unit. Remove motors and encoders!)
- Heating and Colling Rate: 50 °C x h<sup>-1</sup>
- Operating Temperature: Ambient temperature (-10°C to 50°C)
- Travel Resolution: 2 µm (if manually driven)
- Material:
  - Body: EN AW-6082, EN AW-5057, AISI 304 (1.4301), AISI 316L (1.4435)
  - Spindle and nut : AISI 304 (1.4305), Bronze (2.1090)
  - Gear: Aluminum-Bronze, AISI 303 (1.4305)
  - Bellows: AISI 316L (1.4404)
  - Linear rails: Stainless Steel, Fluororubber
  - Anodized: EN AW-6082, EN AW-5057
  - Ball bearings : Stainless Steel
  - Slot nuts : Galvanised Steel, Spring Steel
  - Fasteners : Stainless Steel (grade A2 or higher)
- Tolerances:
  - Machined Parts: ISO 2768 -m -K
  - Welded Structures: ±1 mm and ±1°



#### Caution!

Specification can change if some upgrades or accessories are mounted to the main product.

## 5 Installation of the Stage

Before unpacking, optically inspect the parcel. If damage is found, take pictures of the parcel and send them to Ferrovac AG immediately. Package content depends on each specific Boomerax configuration. Compare content with the delivery note. Any damage or missing item must be reported to Ferrovac **within 48 hours after delivery**.



### Caution!

- Ensure enough work space on a clean table for unpacking and inspection
- Some products of Ferrovac might be shipped under UHV! Sudden uncontrolled venting cause damage to pumps and valves
- Read manuals carefully before using any device
- Never expose any component of the product/system to physical shock or aggressive chemicals
- Neither hit the CF flange knife edge nor any bellows

### 5.1 Unpacking and Installation

The Product, its components and accessories are sealed in a cleaned plastic bag. Do not open and remove it until you are ready to mount the assemblies to the system. Prepare the system where you want to mount the stage according to its operations manual. Prepare a very clean, dust-free bench. Carefully unpack the Product and perform a visual check for any damage of the package, its contents and accessories.

As for all UHV type equipment, clean, lint-free gloves should be used for handling the parts exposed to vacuum. All operations should be conducted on the prepared clean dust-free bench. Locate the stage to the system mounting flange using a new, clean CF copper Conflat gasket, pump and bake as necessary. For bakeout, please refer to section 0

## 6 Operation



### Caution!

It is the responsibility of the operator to continuously and before each use observe the overall technical condition (externally recognizable deficits and damage as well as alterations to the operational behavior) of the system!

The Boomerax Z stage is a rugged component for translating linear motion through a lead-screw applied to a bellows stack. The bellows stack is supported in a precision kinematic guide system, allowing 'Z' motion according to its specifications. For Z adjustment, the precision micrometer drives can be used, where a precision up to 2  $\mu\text{m}$  can be achieved manually. The motorized and encoded upgrade version can achieve higher resolutions.

## 7 Maintenance

### 7.1 Venting and pumpdown



### Caution!

- If vented through pressurized gas, make sure that the pressure does not exceed 1000 mbar. Overpressure may damage the bellows, viewports or other pressure sensitive components.
- Make sure that all parts of the affecting system are strictly at room temperature before venting!
- CF knife-edges are very sensitive! Avoid using any sharp instrument in the vicinity of the knife-edge. CF flanges must be handled by qualified personnel only!

## 7.2 Bake-out



### Caution!

- Always check the vacuum conditions before and during bake-out. Do not start a bake-out if pressure is higher than 1E-7mbar
- Motors, encoders and other parts which are not specified for your bakeout temperature have to be removed
- The maximum baking temperature of the product may never be exceeded.
- Heating and cooling rate should not exceed 50 °C x h-1
- During bake-out, recheck that the pumping system is running normally and that the vacuum level does not exceed the low 1E-6 mbar range.

After having mounted the Boomerax Z stage, a chamber bakeout might be carried out. Reaching vacuum levels below approximately 5E-9 mbar requires bakeout at a temperature above 100°C for a sufficiently long time. Such a bakeout should always be carried out along with the chamber bakeout. Since the absorbates have to be removed from the system during bakeout, it is advisable to always pump the volume. Make sure that a pumping system is used that does not automatically vent in case of power failure; the latter could lead to damage of UHV components due to rapid oxidation.

For the bakeout, pump the system down to a pressure lower than <1E-7 mbar. Any motors and encoders, as well as non-bakeable items (i.e. plastic lids, packing material, tools, non-bakeable cables, pressure gauge electronics, flammable substances etc.) always need to be removed from the bakeout zone.

For the bakeout, only use an original Ferrovac heater unit with the correct operating voltage. In case no Ferrovac original isolation jacket and heater is used, install heating and isolation equipment according to you laboratory's standard procedures for baking UHV systems. Ferrovac declines all warranty for damages that may occur due to overheating if third party equipment is used for bakeout. The maximum bakeout temperature of the Boomerax bellows is 200°C. Note that only the bellows themselves need to be heated up during bake-out. During bakeout, the heating and cooling rate should not exceed 50 °C per hour. Recheck that the pumping system is running normally and that the vacuum level during bakeout does not exceed the low 1E-6 mbar range.

## 7.3 After Bake-out / During Normal Operation

After bakeout, ensure that the lead-screw is adequately lubricated. The lead-screw requires periodic lubrication a using high temperature, high performance lubricant (e.g. Motorex 3000, **not UHV compatible!**). Apply directly to the screw using a suitable paint brush. If baked frequently, it might be necessary to lubricate the guide rails (e.g. Du Pont KRYTOX GPL225, **not UHV compatible!**).

## 8 Options and Upgrades



### Caution!

Always ensure visual contact before and during the operation of motorized components, to ensure that no collisions occur between components in or around the chamber/system.

Options and upgrades for the Boomerax Z stages are listed below. For details, visit our website [www.ferrovac.com](http://www.ferrovac.com).

### 8.1 Stepper Motor Kit

The drive unit (stepper motor) can be mounted on two positions on the Boomerax Z stage, regardless of the nominal size.

**\*Option 1:** Laterally mounted, the motor is coupled with the spindle over a 2:1 gear unit.

- More accurate
- Higher torque
- Composition is shorter
- Bigger backlash
- Lower speed

**\*Option 2:** Mounted on the top, the motor is directly coupled with the spindle drive unit.

- Small backlash
- Higher speed
- Composition is narrower
- Less accurate (bigger step size)
- Lower torque



Z Stage	Position*	Suitable Motor Kit	Max. Torque	Motor Datasheet
MZ40...	1	MOTN17T0.7-0006	0.74 Nm	<a href="#">ST4118D3004-B</a>
	2			
MZ63...	1	MOTN24T3-0006	3 Nm	<a href="#">ST6018L3008-B</a>
	2	MOTN24T3-0010		
	1	MOTN24T3.6-0006	3.6 Nm	<a href="#">ST6018L3008-B</a>
	2	MOTN24T3.6-0010		





8.1.3 Motor Kit MOTN24T3.6-XXXX

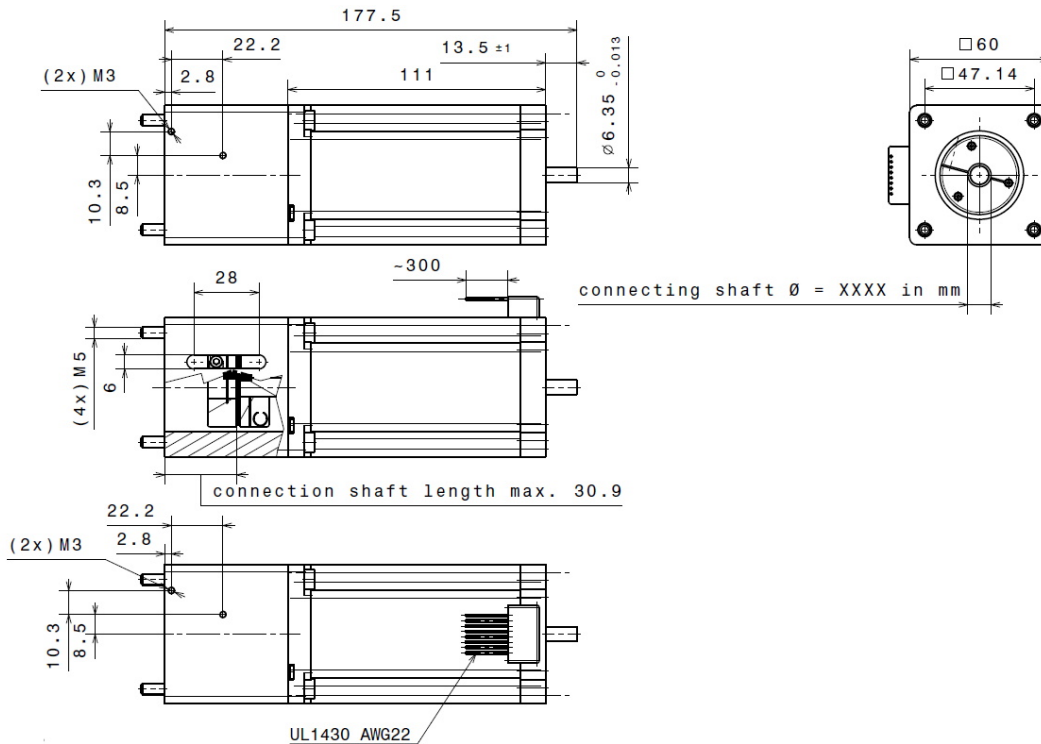

TECHNICAL DATA FOR STEPPER MOTOR KIT:

- Motor Type: ST6018D4508-A
- Motor Size: NEMA 24 stepper, 60x60 mm, Length: 111 ± 1 mm (177.5 mm incl. adapter)
- Max Torque: 3.6Nm
- Resolution: 1.8 °/step
- Voltage: 3.38 VDC
- AMPS/PHASE: 4.5 A
- Bakeout Temperature: Not bakeable (**remove for bake-out!**)
- Operating Temperature: Ambient temperature (-10°C to 50°C)

TOURQUE CURVES: (SOURCE: NANOTEC.COM, NOVEMBER 2019)

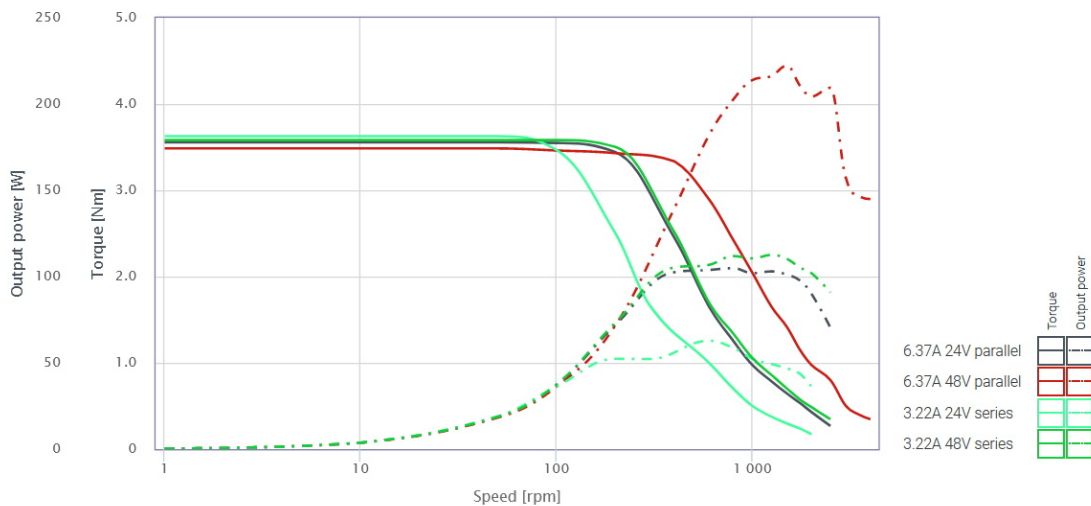

## 8.2 Limit/Position Switch

Electrical limit/position switches for Boomerax Z Manipulators.

Specifications:

Product code: MZLIMELKIT



### TECHNICAL DATA FOR LIMIT/POSITION SWITCH KIT:

- normally closed
- max. voltage: 250 VAC, 24VDC
- max. continuous current: 10.1 A
- min. switching capacity: 12 VDC, 10mA
- temperature range: -40°C ~ 150°C (switch and wiring are bakeable)
- adjustable position
- incl. 2x Amphenol C091B plugs (**not bakeable**)

#### 8.2.1 Limit Switch Adjustment



### Caution!

Always ensure visual contact before and during the operation of motorized components, to ensure that no collisions occur between components in or around the chamber/system.

- Step 1. As the first step in adjusting the limit switches, retract the Z Stage to the lowest possible. Do not try to exceed this minimum value as it can cause the product to jam or get broke.
- Step 2. Adjust the Limit Switch: loosen (**only untighten them, do not remove**) the two fixing screws of the limit switch. After, move the switch until you hear the switch click or if you measure where the switch is switching. Now set the Limit Switch exactly at this position by tightening the two fixing screws.
- Step 3. Extend the actuator: Now that we have one limit set, go to the maximum position to the opposite extreme.
- Step 4. **Adjust the Limit Switch again:** Repeat **Step 2** to set the limit switch at the other extreme position. This is the extended most extreme position.
- Step 5. Checking the Limit Switch: This is the final step of adjusting the limit switches of your Boomerax Z stage. In this step, you need to ensure whether the switches are set properly, and check whether there are any drifts in direction. To check this, run an application that moves from limit switch to limit switch. If it runs smoothly without any problem, then it means that the limit switches have been set correctly.

### 8.3 Weight Support

If a Boomerax Z Stage is mounted horizontally and combination with an XY stage, e.g. form the Boomerax series MXY63CF63TCF63T, we recommend using a weight support structure MZS (for detailed product code see table below) to reduce the mechanical stress on the mounting flange. This support structure is flexible and supports the Z-stage in any position, regardless of the XY-stage moves.

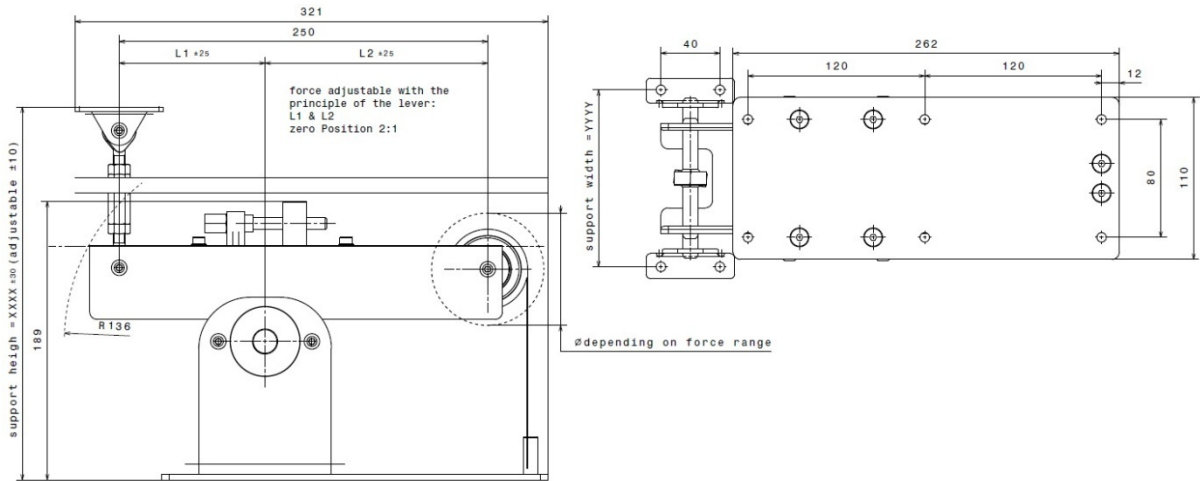

Constant Spring Force [N]	Support Force [N]	Product code	Dimension Y [mm]		Dimension X [mm]
			For MZ40...	For MZ63...	customizable
73.7	81-156	MZS74-XXXX-YYYY	72	120	255 ≤ Y ≤ 1219
147	165-290	MZS147-XXXX-YYYY			
182	200-393	MZS182-XXXX-YYYY			

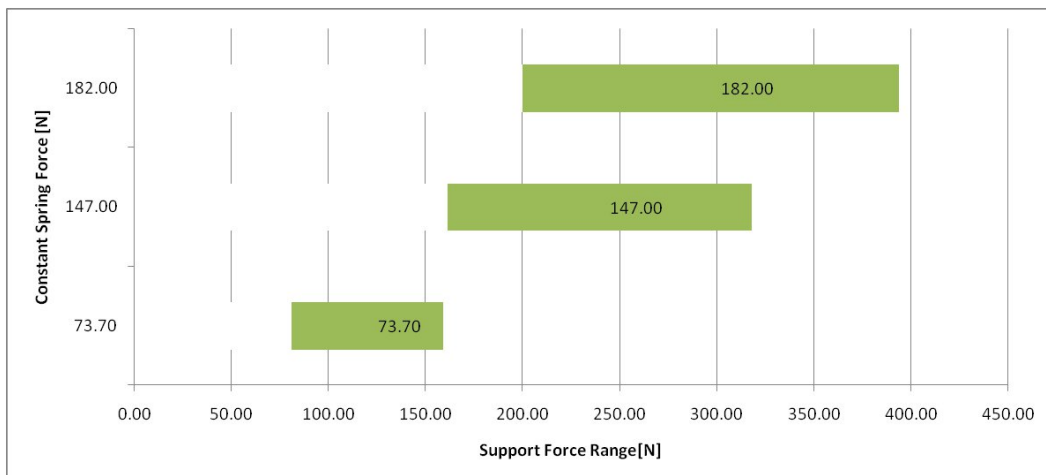

### 8.4 Linear Absolute Optical Encoder Kit for X-Translator

To increase the accuracy it is possible to mount different kind of encoders.

Encoder Type	Encoder Resolution	Product code	Compatibility		measuring length
			MZ40...	MZ63...	
Incremental NOE2	4000CPR	UPGRADEMOT5(+ENCIN4000)	✗	✓	360°
		UPGRADEMOT6.35(+ENCIN4000)	✓	✗	360°
Absolute LAK	78nm	UPGRADEMZ(+MZENCLAK100)	✓	✓	100mm
		UPGRADEMZ(+MZENCLAK200)	✓	✓	200mm
		UPGRADEMZ(+MZENCLAK300)	✓	✓	300mm
		UPGRADEMZ(+MZENCLAK500)	✓	✓	500mm
		UPGRADEMZ(+MZENCLAK750)	✓	✓	750mm
		UPGRADEMZ(+MZENCLAK1000)	✓	✓	1000mm
		UPGRADEMZ(+MZENCLAK1200)	✓	✓	1250mm

#### 8.4.1 Incremental Encoder: NOE2

The incremental encoders are directly mounted on the stepper motors and allow to control easily in closed-loop mode.

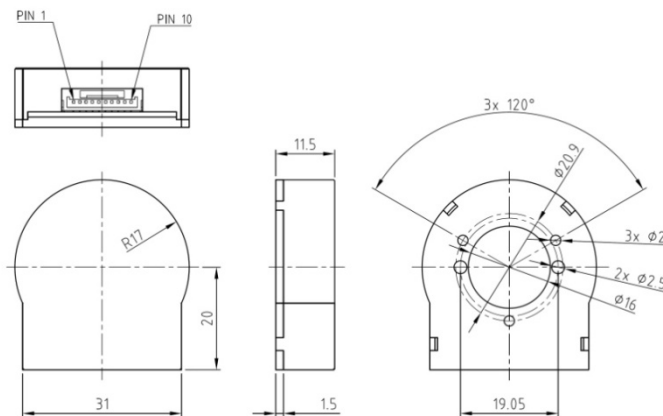

PIN assignment JST GH - 10pole	
PIN No.	Function
1	GND
2	A
3	A\
4	B\
5	B
6	I\
7	I
8	GND
9	+ 5V (NOE2-05)/ +24V (NOE2-24)
10	GND

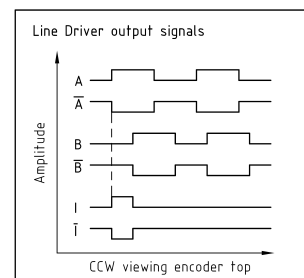

#### TECHNICAL DATA FOR INCREMENTAL ENCODER KIT:

- Shaft Diameter:
  - UPGRADEMOT5(+ENCIN4000): 5 mm
  - UPGRADEMOT6.35(+ENCIN4000): 6.35 mm
- Encoder Resolution: 4000 CPR
- Operating Voltage: 5 VDC
- Current Consumption: 30 mA
- Temperature range: -20°C ~ 85°C (**not bakeable**)
- Humidity: max. 90 % (no condensation)
- Limit Speed: 3600 RPM
- Output Signals: phase A, A\, B, B\, I, I\
- Limit Frequency: 240 kHz
- Pulse Width: 180° ± 30°e
- Phase Shift: 90° ± 18°e
- Max. Output Current per Channel: 40 mA (@Vcc=5 V, Vout=2.7 V)
- Signal Level Low: <2.0 V (@I\_load=20 mA), High: 3 V (@I\_load=20 mA)

## 8.4.2 Absolute encoder: LAK

### TECHNICAL DATA FOR ABSOLUTE ENCODER KIT:

- Manufacturer article number: LAK14-710A-US71/U=0,13 (special connector)
- Connector: LEMO #FPG.1 B.316.CLAD42
- Interface: BiSS C<sup>1</sup>
- Operating Temperature: -0°C ~ 50°C (**not bankable, remove for bake-out!**)
- Storage temperature: -20°C ~ 70°C (**not bakable**)

For more details please see Numerik Jena LAK manual: [Download Manual LAK \(pdf\)](#)

## 9 Additional information

### 9.1 Return of defective items

Ferrovac AG requires a completed declaration of contamination form and will issue an RMA (Return of Materials Authorization) form, before any items are factory returned. Please contact us beforehand. You will be given an RMA number and information on how to proceed with the return of defective items.

### 9.2 Downloads

The latest version of this manual can be downloaded from our website [Ferrovac.com](http://Ferrovac.com). For any suggestions or questions concerning this manual, please don't hesitate to contact us.

Ferrovac AG  
Thurgauerstrasse 72  
8050 Zürich  
Phone: +41 (0) 44 273 16 38  
E-Mail: [sales@ferrovac.com](mailto:sales@ferrovac.com)  
Website: [www.ferrovac.com](http://www.ferrovac.com)

---

<sup>1</sup> BiSS is a trade mark of IC-Haus AG