

MERITOR WABCO

Enhanced Easy-Stop™ Trailer ABS with PLC

**Maintenance Manual MM-0180
Revised 02-10**



- **2S/1M Basic**
- **2S/2M Standard**
- **2S/2M, 4S/2M, 4S/3M Premium**

Before You Begin

This manual contains maintenance procedures for Meritor WABCO's Enhanced Easy-Stop™ Trailer ABS with PLC. Before you begin procedures:

1. Read and understand all instructions and procedures before you begin to service components.
2. Read and observe all Caution and Warning safety alerts that precede instructions or procedures you will perform. These alerts help to avoid damage to components, serious personal injury, or both.
3. Follow your company's maintenance and service, installation, and diagnostics guidelines.
4. Use special tools when required to help avoid serious personal injury and damage to components.

Safety Alerts, Torque Symbol and Notes

 WARNING	A Warning alerts you to an instruction or procedure that you must follow exactly to avoid serious personal injury and damage to components.
 CAUTION	A Caution alerts you to an instruction or procedure that you must follow exactly to avoid damage to components and possible serious injury.
	A torque symbol alerts you to tighten fasteners to a specified torque value.
NOTE	A Note provides information or suggestions that help you correctly service a component.

Access Information on ArvinMeritor's Web Site

Additional maintenance and service information for ArvinMeritor's commercial vehicle systems component lineup is also available at arvinmeritor.com.

To access information, click on Products & Services/Tech Library Icon/HVS Publications. The screen will display an index of publications by type.

Additional Information

Call ArvinMeritor's Customer Service Center at 800-535-5560 to order the following publications.

- **Enhanced Easy-Stop™ Installation Guide (Wall Chart)** (TP-0155)
- **Blink Code Diagnostics Card for Easy-Stop™ and Enhanced Easy-Stop™** (TP-0173)
- **Driver Tips** (SP-93161)*
- **How to Brake with ABS audio cassette** (SP-94126)*
- **Enhanced Easy-Stop™ Training Guide Workbook** (TP-0143)
- **Trailer ABS Service and Support Reference Card** (TP-9803)
- **Trailer ABS Technical Service Support Reference Card** (TP-9804)
- **What Every Driver Should Know About ABS** (T-96159V)
- **Enhanced Easy-Stop™ Training Video** (T-0197V)
- **Drivetrain Plus™ by ArvinMeritor Technical Electronic Library on CD.** Features product and service information on most Meritor, ZF Meritor and Meritor WABCO products. \$20. Order TP-9853.

*For Spanish version, add SP to the item number. For French version, add FR to the item number.

 Asbestos and Non-Asbestos Fibers Warnings	1
Section 1: Introduction	
Maintenance Manual Information	3
Identifying Enhanced Easy-Stop Trailer ABS	
Enhanced Easy-Stop Trailer ABS Parts	
What Is Meritor WABCO’s Enhanced Easy-Stop Trailer ABS?	4
System Configuration	
How Trailer ABS Works	
Section 2: System Components	5
Section 3: ABS Questions and Answers	
The Electronic Control Unit (ECU)	9
Power Line Carrier (PLC) Communications Questions and Answers	
ABS Indicator Lamps	10
ABS Indicator Lamp (on Dash)	
ABS Indicator Lamp (on Trailer)	
Types of Faults	12
Section 4: System Configurations	
Enhanced Easy-Stop Installation Diagrams	13
Power Cable Wiring Diagrams	24
Section 5: Diagnostics	
Diagnostics	25
Important PLC Information for Blink Code Diagnostics	
TOOLBOX Software	
Blink Code Diagnostics	29
Diagnostic Tool (Blink Code Check)	30
Section 6: Component Replacement	
Wheel Speed Sensor	33
How to Remove a Sensor	
How to Install a Sensor	
ABS Relay Valve	34
How to Remove a Standard ABS Relay Valve	
How to Install a Standard ABS Relay Valve	
The ECU/Valve Assembly	35
How to Remove the ECU/Valve Assembly	
How to Install the ECU/Valve Assembly	
Tank-Mounted	36
Bracket-Mounted to Cross Member of Vehicle (2S/1M Basic)	
Mounted to Cross Member of Vehicle — Standard and Premium Mounting	
Bracket Not Supplied	37
Replacing the ECU or Modulator Valve	38

Section 7: Sensor Adjustment & Component Testing

How to Test Wheel Speed Sensors	39
Sensor Test Procedure	
Sensor Output Voltage Test	
Check ABS Functions	
ABS External Modulator Valve	
End of Line Testing	40
End of Line Testing Procedure Using TOOLBOX Software (All Installations)	
End of Line Testing without TOOLBOX Software	43
2S/1M Basic	
Inspect the Sensor and Air Line Installation (2S/2M Standard)	44
Inspect the Sensor and Air Line Installation (2S/2M, 4S/2M and 4S/3M Premium)	45
Perform End of Line Test (Standard and Premium Installations)	46
Fault Code Check (All Installations)	

Appendix I

Trailer ABS Indicator Lamp on Vehicle Dash.....	A-1
---	-----



ASBESTOS FIBERS WARNING

The following procedures for servicing brakes are recommended to reduce exposure to asbestos fiber dust, a cancer and lung disease hazard. Material Safety Data Sheets are available from ArvinMeritor.

Hazard Summary

Because some brake linings contain asbestos, workers who service brakes must understand the potential hazards of asbestos and precautions for reducing risks. Exposure to airborne asbestos dust can cause serious and possibly fatal diseases, including asbestosis (a chronic lung disease) and cancer, principally lung cancer and mesothelioma (a cancer of the lining of the chest or abdominal cavities). Some studies show that the risk of lung cancer among persons who smoke and who are exposed to asbestos is much greater than the risk for non-smokers. Symptoms of these diseases may not become apparent for 15, 20 or more years after the first exposure to asbestos.

Accordingly, workers must use caution to avoid creating and breathing dust when servicing brakes. Specific recommended work practices for reducing exposure to asbestos dust follow. Consult your employer for more details.

Recommended Work Practices

1. **Separate Work Areas.** Whenever feasible, service brakes in a separate area away from other operations to reduce risks to unprotected persons. OSHA has set a maximum allowable level of exposure for asbestos of 0.1 f/cc as an 8-hour time-weighted average and 1.0 f/cc averaged over a 30-minute period. Scientists disagree, however, to what extent adherence to the maximum allowable exposure levels will eliminate the risk of disease that can result from inhaling asbestos dust. OSHA requires that the following sign be posted at the entrance to areas where exposures exceed either of the maximum allowable levels:

**DANGER: ASBESTOS
CANCER AND LUNG DISEASE HAZARD
AUTHORIZED PERSONNEL ONLY
RESPIRATORS AND PROTECTIVE CLOTHING
ARE REQUIRED IN THIS AREA.**

2. **Respiratory Protection.** Wear a respirator equipped with a high-efficiency (HEPA) filter approved by NIOSH or MSHA for use with asbestos at all times when servicing brakes, beginning with the removal of the wheels.
3. **Procedures for Servicing Brakes.**
 - a. Enclose the brake assembly within a negative pressure enclosure. The enclosure should be equipped with a HEPA vacuum and worker arm sleeves. With the enclosure in place, use the HEPA vacuum to loosen and vacuum residue from the brake parts.
 - b. As an alternative procedure, use a catch basin with water and a biodegradable, non-phosphate, water-based detergent to wash the brake drum or rotor and other brake parts. The solution should be applied with low pressure to prevent dust from becoming airborne. Allow the solution to flow between the brake drum and the brake support or the brake rotor and caliper. The wheel hub and brake assembly components should be thoroughly wetted to suppress dust before the brake shoes or brake pads are removed. Wipe the brake parts clean with a cloth.
 - c. If an enclosed vacuum system or brake washing equipment is not available, employers may adopt their own written procedures for servicing brakes, provided that the exposure levels associated with the employer's procedures do not exceed the levels associated with the enclosed vacuum system or brake washing equipment. Consult OSHA regulations for more details.
 - d. Wear a respirator equipped with a HEPA filter approved by NIOSH or MSHA for use with asbestos when grinding or machining brake linings. In addition, do such work in an area with a local exhaust ventilation system equipped with a HEPA filter.
 - e. **NEVER** use compressed air by itself, dry brushing, or a vacuum not equipped with a HEPA filter when cleaning brake parts or assemblies. **NEVER** use carcinogenic solvents, flammable solvents, or solvents that can damage brake components as wetting agents.
4. **Cleaning Work Areas.** Clean work areas with a vacuum equipped with a HEPA filter or by wet wiping. **NEVER** use compressed air or dry sweeping to clean work areas. When you empty vacuum cleaners and handle used rags, wear a respirator equipped with a HEPA filter approved by NIOSH or MSHA for use with asbestos. When you replace a HEPA filter, wet the filter with a fine mist of water and dispose of the used filter with care.
5. **Worker Clean-Up.** After servicing brakes, wash your hands before you eat, drink or smoke. Shower after work. Do not wear work clothes home. Use a vacuum equipped with a HEPA filter to vacuum work clothes after they are worn. Launder them separately. Do not shake or use compressed air to remove dust from work clothes.
6. **Waste Disposal.** Dispose of discarded linings, used rags, cloths and HEPA filters with care, such as in sealed plastic bags. Consult applicable EPA, state and local regulations on waste disposal.

Regulatory Guidance

References to OSHA, NIOSH, MSHA, and EPA, which are regulatory agencies in the United States, are made to provide further guidance to employers and workers employed within the United States. Employers and workers employed outside of the United States should consult the regulations that apply to them for further guidance.



NON-ASBESTOS FIBERS WARNING

The following procedures for servicing brakes are recommended to reduce exposure to non-asbestos fiber dust, a cancer and lung disease hazard. Material Safety Data Sheets are available from ArvinMeritor.

Hazard Summary

Most recently manufactured brake linings do not contain asbestos fibers. These brake linings may contain one or more of a variety of ingredients, including glass fibers, mineral wool, aramid fibers, ceramic fibers and silica that can present health risks if inhaled. Scientists disagree on the extent of the risks from exposure to these substances. Nonetheless, exposure to silica dust can cause silicosis, a non-cancerous lung disease. Silicosis gradually reduces lung capacity and efficiency and can result in serious breathing difficulty. Some scientists believe other types of non-asbestos fibers, when inhaled, can cause similar diseases of the lung. In addition, silica dust and ceramic fiber dust are known to the State of California to cause lung cancer. U.S. and international agencies have also determined that dust from mineral wool, ceramic fibers and silica are potential causes of cancer.

Accordingly, workers must use caution to avoid creating and breathing dust when servicing brakes. Specific recommended work practices for reducing exposure to non-asbestos dust follow. Consult your employer for more details.

Recommended Work Practices

1. **Separate Work Areas.** Whenever feasible, service brakes in a separate area away from other operations to reduce risks to unprotected persons.
2. **Respiratory Protection.** OSHA has set a maximum allowable level of exposure for silica of 0.1 mg/m³ as an 8-hour time-weighted average. Some manufacturers of non-asbestos brake linings recommend that exposures to other ingredients found in non-asbestos brake linings be kept below 1.0 f/cc as an 8-hour time-weighted average. Scientists disagree, however, to what extent adherence to these maximum allowable exposure levels will eliminate the risk of disease that can result from inhaling non-asbestos dust. Therefore, wear respiratory protection at all times during brake servicing, beginning with the removal of the wheels. Wear a respirator equipped with a high-efficiency (HEPA) filter approved by NIOSH or MSHA, if the exposure levels may exceed OSHA or manufacturers' recommended maximum levels. Even when exposures are expected to be within the maximum allowable levels, wearing such a respirator at all times during brake servicing will help minimize exposure.
3. **Procedures for Servicing Brakes.**
 - a. Enclose the brake assembly within a negative pressure enclosure. The enclosure should be equipped with a HEPA vacuum and worker arm sleeves. With the enclosure in place, use the HEPA vacuum to loosen and vacuum residue from the brake parts.
 - b. As an alternative procedure, use a catch basin with water and a biodegradable, non-phosphate, water-based detergent to wash the brake drum or rotor and other brake parts. The solution should be applied with low pressure to prevent dust from becoming airborne. Allow the solution to flow between the brake drum and the brake support or the brake rotor and caliper. The wheel hub and brake assembly components should be thoroughly wetted to suppress dust before the brake shoes or brake pads are removed. Wipe the brake parts clean with a cloth.
 - c. If an enclosed vacuum system or brake washing equipment is not available, carefully clean the brake parts in the open air. Wet the parts with a solution applied with a pump-spray bottle that creates a fine mist. Use a solution containing water, and, if available, a biodegradable, non-phosphate, water-based detergent. The wheel hub and brake assembly components should be thoroughly wetted to suppress dust before the brake shoes or brake pads are removed. Wipe the brake parts clean with a cloth.
 - d. Wear a respirator equipped with a HEPA filter approved by NIOSH or MSHA when grinding or machining brake linings. In addition, do such work in an area with a local exhaust ventilation system equipped with a HEPA filter.
 - e. **NEVER** use compressed air by itself, dry brushing, or a vacuum not equipped with a HEPA filter when cleaning brake parts or assemblies. **NEVER** use carcinogenic solvents, flammable solvents, or solvents that can damage brake components as wetting agents.
4. **Cleaning Work Areas.** Clean work areas with a vacuum equipped with a HEPA filter or by wet wiping. **NEVER** use compressed air or dry sweeping to clean work areas. When you empty vacuum cleaners and handle used rags, wear a respirator equipped with a HEPA filter approved by NIOSH or MSHA, to minimize exposure. When you replace a HEPA filter, wet the filter with a fine mist of water and dispose of the used filter with care.
5. **Worker Clean-Up.** After servicing brakes, wash your hands before you eat, drink or smoke. Shower after work. Do not wear work clothes home. Use a vacuum equipped with a HEPA filter to vacuum work clothes after they are worn. Launder them separately. Do not shake or use compressed air to remove dust from work clothes.
6. **Waste Disposal.** Dispose of discarded linings, used rags, cloths and HEPA filters with care, such as in sealed plastic bags. Consult applicable EPA, state and local regulations on waste disposal.

Regulatory Guidance

References to OSHA, NIOSH, MSHA, and EPA, which are regulatory agencies in the United States, are made to provide further guidance to employers and workers employed within the United States. Employers and workers employed outside of the United States should consult the regulations that apply to them for further guidance.

**Maintenance Manual
Information**

This manual contains service and diagnostic information for Meritor WABCO Enhanced Easy-Stop™ Trailer ABS with Power Line Carrier (PLC) capability.

Identifying Enhanced Easy-Stop Trailer ABS

To identify Enhanced Easy-Stop, check the identification tag on the Electronic Control Unit (ECU). **Figure 1.1.** The part numbers for Enhanced Easy-Stop systems are:

- 400 500 101 0(2S/1M Basic for standard trailers)
- 400 500 104 0(2S/1M Basic for dollies and steerables)
- 400 500 102 0(2S/2M Standard)
- 400 500 103 0(2S/2M, 4S/2M and 4S/3M Premium)

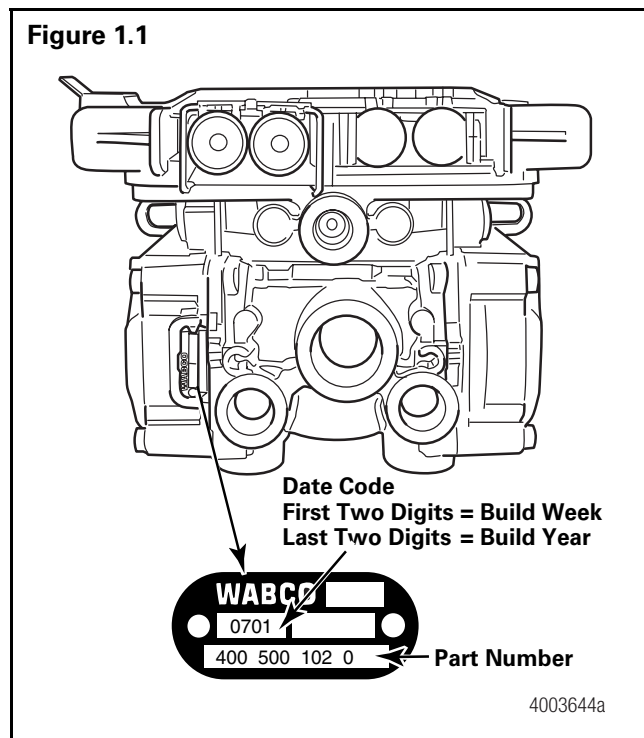

If you are servicing or using blink code diagnostics for Easy-Stop Trailer ABS (Easy-Stop ECUs with part numbers other than those listed above), please use Meritor WABCO Maintenance Manual 33.

If you are not able to identify the version, or to request service literature, please contact ArvinMeritor’s Customer Service Center at 800-535-5560.

This manual does not contain Original Equipment Manufacturer (OEM) installation instructions. New installations require the following documentation:

- Enhanced Easy-Stop Basic (2S/1M): TP-20212
- Enhanced Easy-Stop Standard (2S/2M): TP-20213
- Enhanced Easy-Stop Premium (2S/2M, 4S/2M and 4S/3M): TP-20214

Enhanced Easy-Stop Trailer ABS Parts

Parts book PB-96133 lists Meritor WABCO Easy-Stop replacement parts. To obtain a copy, contact ArvinMeritor’s Customer Service Center at 800-535-5560.

For warranty information, contact ArvinMeritor’s Customer Service Center (800-535-5560) and ask for TP-99128, *Meritor WABCO Trailer ABS Warranty Procedure.*

What Is Meritor WABCO's Enhanced Easy-Stop Trailer ABS?

Meritor WABCO's Easy-Stop Trailer ABS is an electronic, self-monitoring system that works with standard air brakes. In addition, Enhanced Easy-Stop includes Power Line Carrier (PLC) capability. PLC information is included in the ABS Q & A Section of this manual. The major components of the system are the **Electronic Control Unit (ECU)/Valve Assembly**, **ABS modulator valve (for 3M systems)**, **tooth wheel** and **wheel speed sensor**. **Figure 1.2**.

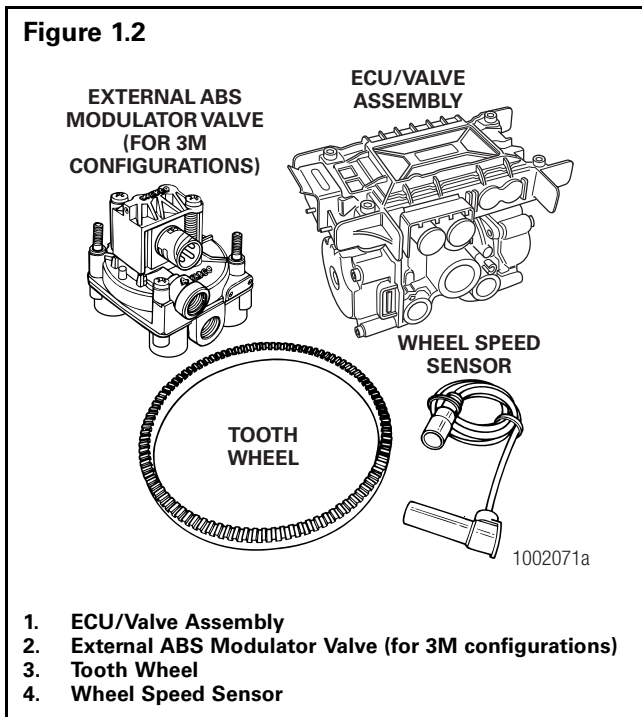

System Configuration

The ABS **configuration** defines the number of wheel speed sensors and ABS modulator valves used in a system. For example, a **2S/1M** configuration includes two wheel sensors and one ABS modulator valve. A **2S/2M** configuration includes two wheel sensors and two ABS modulator valves. A **4S/2M** configuration includes four wheel sensors and two ABS modulator valves.

A 4S/3M configuration consists of an ECU/dual modulator valve assembly and one external ABS modulator valve.

There is a specific ECU/valve assembly for each configuration:

- For 2S/1M Basic, the assembly consists of an ECU and a single modulator valve assembly
- For 2S/2M Standard and 2S/2M, 4S/2M and 4S/3M Premium, the assembly consists of an ECU and a dual modulator valve assembly (one valve that combines the function of two modulator valves). The 2S/2M Standard valve has only two sensor outlets and cannot be upgraded.

How Trailer ABS Works

Meritor WABCO ABS is an electronic system that monitors and controls wheel speed during braking. The system works with standard air brake systems.

ABS monitors wheel speeds at all times and controls braking during wheel lock situations. The system improves vehicle stability and control by reducing wheel lock during braking.

The ECU receives and processes signals from the wheel speed sensors. When the ECU detects a wheel lockup, the unit activates the appropriate modulator valve, and air pressure is controlled.

In the event of a malfunction in the system, the ABS in the affected wheel(s) is disabled; that wheel still has normal brakes. The other wheels keep the ABS function.

Two ABS indicator lamps (one on the dash and one on the side of the trailer) let drivers know the status of the system.

ECU/Valve Assembly (Figure 2.1)

- 12 volt
- Integrated ECU and ABS relay valve
 - ECU and valve assembly are serviceable items.
- The ECU/Valve Assembly may be mounted with the sensors facing either the front or rear of the trailer.

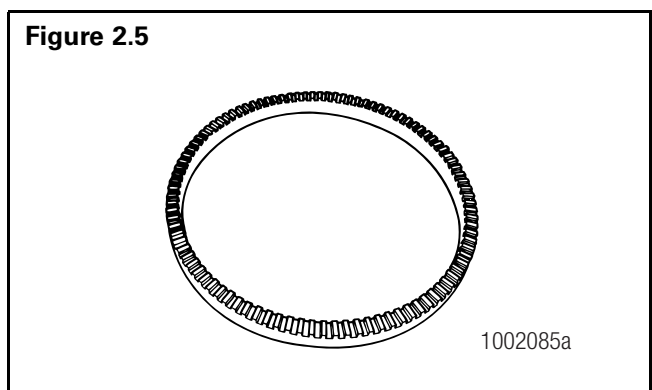
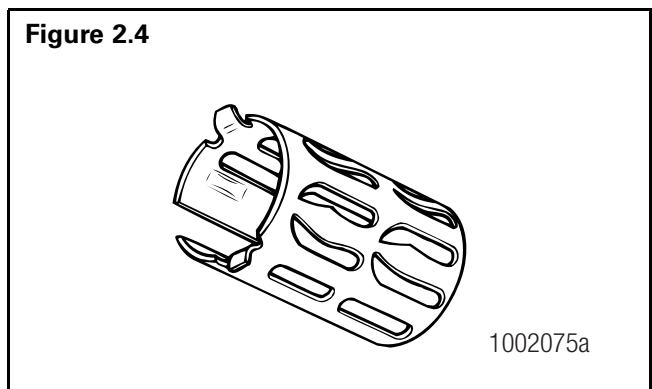
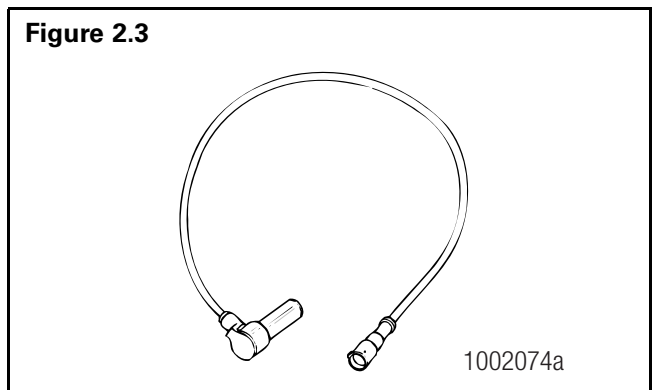
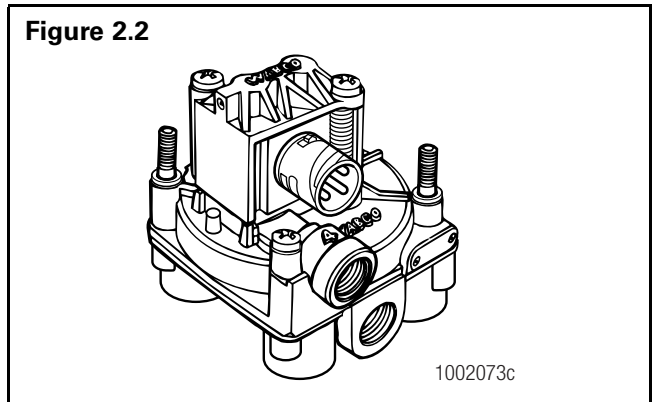
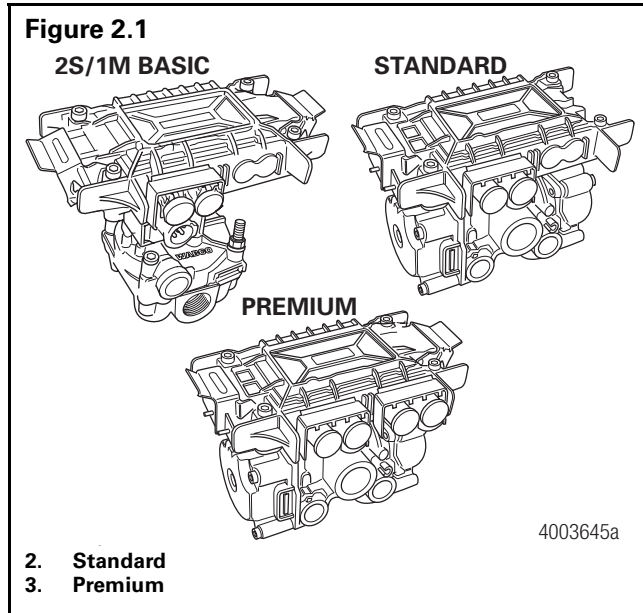

ABS External Modulator Valve (Figure 2.2)

- Controls air pressure to the brake chambers where it is plumbed.
- During ABS operation, the valve adjusts air pressure to the brake chambers to control braking and prevent wheel lock.
- Used in conjunction with ECU/Valve Assembly for 3M systems.

Sensor with Molded Socket (Figure 2.3)

- Measures the speed of a tooth wheel rotating with the vehicle wheel.
- Produces an output voltage proportional to wheel speed.

Sensor Spring Clip (Figure 2.4)

- Holds the wheel speed sensor in close proximity to the tooth wheel.

Tooth Wheel (Figure 2.5)

- A machined ring mounted to the machined surface on the hub of each ABS-monitored wheel.

Cables for Enhanced Easy-Stop (Figure 2.6)

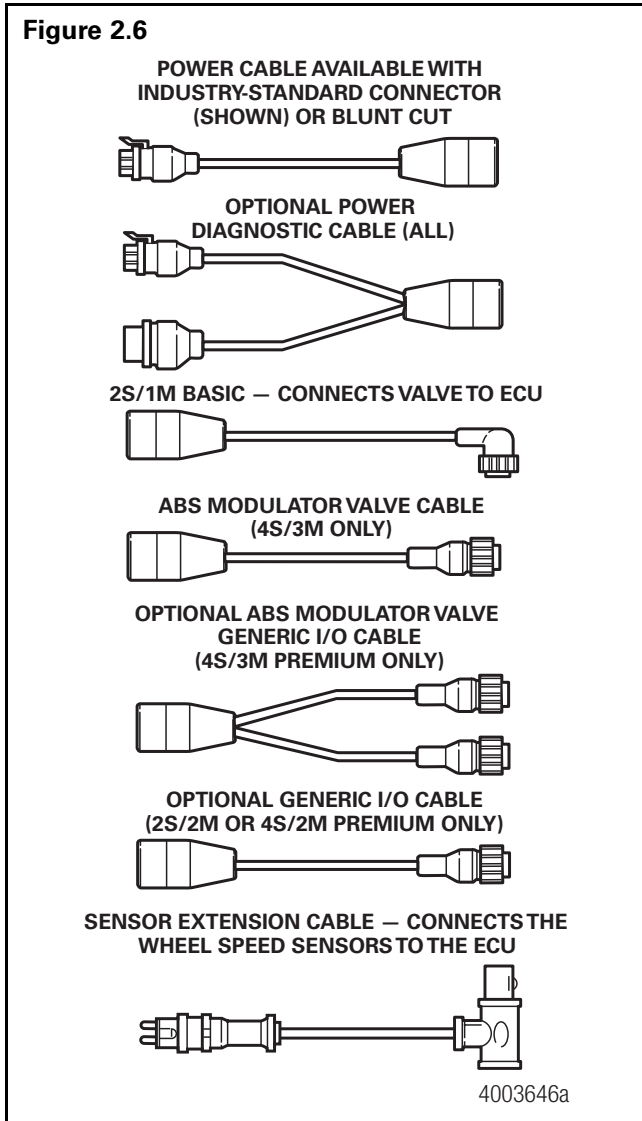

Easy-Stop Trailer ABS Indicator Label

- Provides information about the operation of the ABS indicator lamp and illustrates blink code fault locations.
- Label is self-adhesive and is mounted on the trailer near the ABS indicator lamp.
- If there is no warning label on your trailer, let your supervisor know. Labels are available from Meritor WABCO. Ask for Part Number TP-95172.

TOOLBOX Software (Figure 2.7)

TOOLBOX Software is a PC-based diagnostics program that can display wheel speed data, test individual components, verify installation wiring and more.

Version 4.1 (or higher) supports Enhanced Easy-Stop with PLC, and runs in Windows® 95, 98, NT, 2000 and Me. An RS232 to J1708 converter box is required.

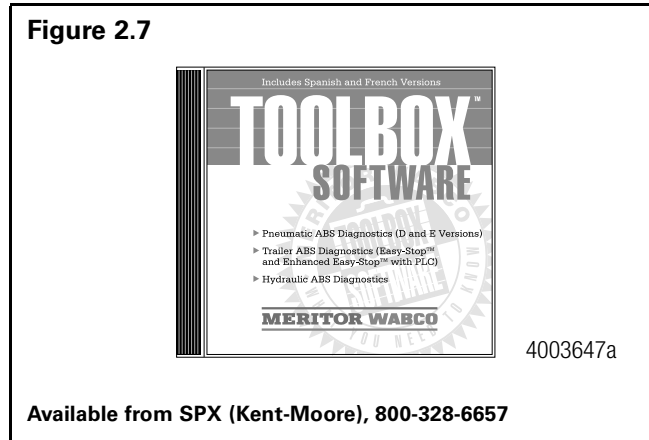

PLC/J1708 Adapter (Figure 2.8)

- Simulates the tractor ABS lamp, ensuring that the trailer ABS is capable of "lighting the light."
- Simulates the trailer ABS lamp, ensuring that the tractor is capable of "lighting the light."
- Use as a trailer/tractor tester to ensure that PLC is functioning properly.

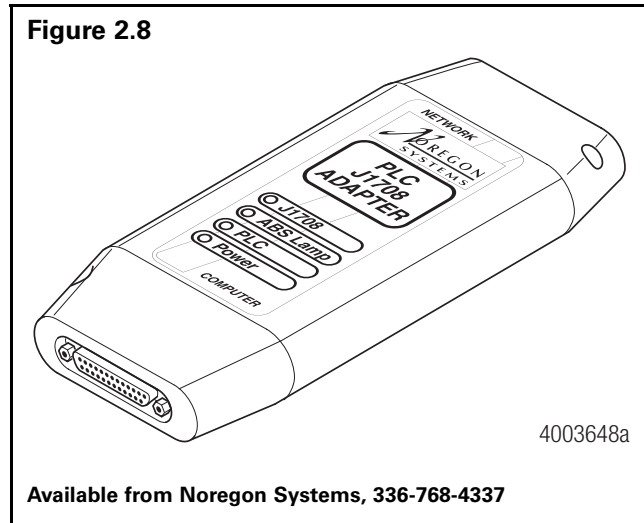

MPSI Pro-Link® 9000 Diagnostic Tool (Figure 2.9)

- Provides diagnostic and testing capability for ABS components.
- Requires a Multiple Protocol Cartridge (MPC) and Meritor WABCO applications card, version 2.0 or higher, for use with Enhanced Easy-Stop with PLC.

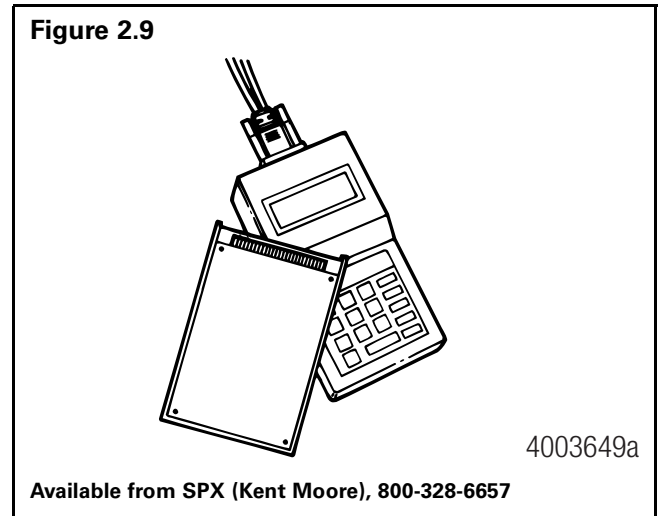

The Electronic Control Unit (ECU)

How do you activate the ECU?

In a constant-powered system, the ECU activates and then begins a self-diagnostic check of the system when you turn the ignition ON. In a stoplight-powered system, the ECU activates when you apply the brakes. All trailers manufactured on or after March 1, 1998 will be equipped with ABS that has constant power capability with stoplight power as back-up.

How does the ECU respond to a wheel approaching lock-up?

The ECU directs the ABS relay valve to function as a modulator valve and adjust air pressure to the chambers up to five times a second. This pressure adjustment allows a wheel (or wheels) to rotate without locking.

Power Line Carrier (PLC) Communications Questions and Answers

What is PLC communications?

PLC stands for Power Line Carrier, which is a method used to communicate information by multiplexing data on the same wire used for the ABS electrical power. PLC communications convert signal message data to a radio frequency (RF) signal on top of the +12V power line providing electrical power to the trailer.

What is multiplexing?

Multiplexing means communicating multiple signals or messages on the same transmission media. This provides an efficient and cost effective means by decreasing the number of wires and connectors which otherwise would be needed. Without multiplexing, it could take several wires and connections in order to transmit several different signals to various locations on a vehicle, but with multiplexing these wires and connectors can be significantly reduced.

Why add PLC technology to tractor and trailer ABS?

By adding PLC technology to the tractor and trailer ABS the industry is able to have the most cost effective means to meet the March 1, 2001 FMVSS-121 in-cab trailer indicator lamp mandate with no additional external hardware, harnesses or connectors. Additionally, this new capability of communicating other information between tractor

and trailers provides many more opportunities to further improve productivity and safety. With every tractor and trailer currently built having ABS technology, integrating PLC technology into the PC board was the logical choice.

How does it work?

The trailer ABS with PLC takes message information to be sent to the tractor and converts it to an RF signal. The signal is then sent over the trailer ABS power line (blue wire) and the tractor ABS with PLC receives the signal. Messages can also be sent from the tractor to the trailer via PLC.

What if a tractor is equipped with PLC technology and the trailer is not, or vice-versa? Can you drive the combination safely in that situation?

Absolutely. If the tractor is equipped with PLC and the trailer is not, or vice-versa, your ABS in-cab trailer indicator lamp will not illuminate, but your ABS will continue to function as normal. To ensure that the trailer ABS is functioning properly, the trailer ABS indicator lamp mounted on the trailer should be utilized.

What if a tractor has one manufacturer's ABS with PLC and the trailer has another manufacturer's ABS with PLC? Will the two systems be compatible and operate the trailer ABS lamp as expected?

Yes. ABS with PLC from different manufacturers are designed to be compatible by controlling the trailer ABS lamp according to the FMVSS-121 standard, even when systems from different manufacturers are connected to each other. However, certain features beyond the control of the trailer ABS indicator lamp may or may not be supported by all devices communicating via PLC. SAE task forces continue to standardize common messages so that maximum compatibility may exist in the future.

How do I diagnose PLC?

PLC can be diagnosed over the J1587/J1708 diagnostic connector on the tractor and trailer using tools designed for PLC diagnostics.

Can I use blink code diagnostics on Enhanced Easy-Stop to diagnose PLC?

Yes. Section 5 of this manual describes the method of performing a blink code check using Constant Power (ignition activation). Blink Code 17 indicates a PLC failure.

Section 3 ABS Questions and Answers

MERITOR WABCO

If PLC does not seem to be operating properly, but I don't get a Blink Code 17 when I run a blink code check, what else could be wrong?

If there is no Blink Code 17, the ECU is functioning properly and does not need to be replaced; however, there could be a problem in the trailer's wiring harness. Check the wiring system and make the necessary repairs. If the problem persists, contact Meritor WABCO for assistance.

ABS Indicator Lamps

NOTE: When replacing the bulb, to ensure proper lamp operation use an incandescent type DOT-approved lamp, or a LED with integral load resistor.

ABS Indicator Lamp (on Dash)

With Enhanced Easy-Stop there are two ABS indicator lamps; one on the vehicle dash and one on the side of the trailer. Refer to Appendix I for information about the operation of this lamp.

ABS Indicator Lamp (on Trailer)

What is the function of the ABS indicator lamp?

The indicator lamp enables a driver to monitor the ABS at all times. Refer to the OEM operating manual for the mounting location of the indicator lamp.

How does the indicator lamp operate?

How the indicator lamp operates depends on whether the ABS is powered by stoplight or constant power:

- If the trailer was manufactured prior to February 28, 1998, or was manufactured outside of the United States, the ABS may be either stoplight or constant powered.
- If the trailer was manufactured March 1, 1998 or later — and was manufactured in the United States — it will have constant power capability. This is mandated by Federal Motor Vehicle Safety Standard (FMVSS) 121.

Check your vehicle specification sheet to determine the type of ABS power. **Table A** and **Table B** in this section illustrate indicator lamp operation on stoplight and constant powered ABS systems.

An ECU with part number 472 500 001 0 manufactured **prior to September 1997** requires all sensed wheels to detect a 4 mph signal to shut off the ABS indicator lamp. Do not confuse this with a faulty ABS system. If the indicator lamp stays on

when the brakes are applied to a moving vehicle, service the ABS system.

Most trailers manufactured **prior to February 1998** require that the brakes be applied to operate the ABS indicator lamp. If the indicator lamp stays on when the brakes are applied to a moving vehicle, service the ABS system.

What does the trailer ABS indicator lamp mean to service personnel?

The trailer ABS indicator lamp on the side of the trailer indicates the status of the trailer ABS. If it comes ON and stays ON when you apply the brakes to a moving vehicle, there is an ABS malfunction. It is normal for the lamp to come ON and go OFF to perform a bulb check, but it should not stay ON when the vehicle is moving above 4 mph. As with any safety system, it is important not to ignore this indicator. If the indicator lamp indicates a malfunction, the vehicle can be operated to complete the trip, but it is important to have it serviced as soon as possible using the appropriate maintenance manual to ensure proper braking performance and that the benefits of ABS remain available to your drivers. Typical ABS indicator lamp mounting locations are illustrated in **Figure 3.1**.

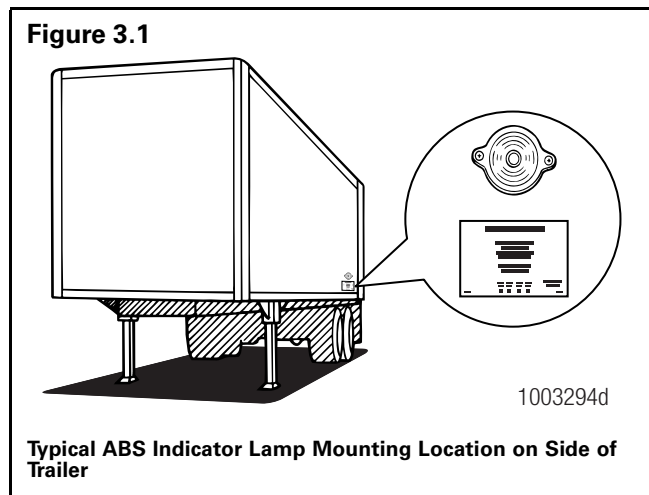

For more information, call ArvinMeritor's Customer Service Center at 800-535-5560.

Can you continue to operate a vehicle when the indicator lamp indicates a fault?

Yes. When a fault exists in the ABS, standard braking returns to the affected wheel, and the ABS still controls other monitored wheels. This lets you complete the trip. You should not ignore the indicator lamp and should have the vehicle serviced as soon as possible after the lamp comes ON and stays ON.

Table A: Stoplight Power

System Power Comes from Activating the Stoplight Circuit.			
Brakes	Fault in System	Vehicle Speed	Indicator Lamp
Released	N.A.	N.A.	OFF
Applied	NO	Less than 4 mph	ON for 3 seconds, then goes OFF.
Applied	NO	Greater than 4 mph	Flashes once, then stays OFF for remainder of stop.
Applied	YES	N.A.	ON

Table B: Constant Power

System Is Ignition Powered.				
Brakes	Ignition	Fault in System	Vehicle Speed	Indicator Lamps (Trailer and Dash)
Released	OFF	N.A.	N.A.	OFF
	ON	NO	Less than 4 mph	ON for 3 seconds, then go OFF.
	ON	NO	Greater than 4 mph	OFF
	ON	YES	N.A.	ON
Applied	OFF	NO	Less than 4 mph	ON for 3 seconds, then go OFF.
	OFF	YES	N.A.	ON
	ON	NO	Less than 4 mph	ON for 3 seconds, then go OFF.
	ON	NO	Greater than 4 mph	OFF
	ON	YES	N.A.	ON

Types of Faults

What is a "fault" in the system?

A fault in the system is a problem that can exist in the ABS or in the system's components. Faults can be either existing faults or intermittent stored faults.

What is an existing fault?

An **existing** fault is a problem that exists currently in the system. For example, a damaged sensor cable is an existing fault that the ECU will detect and store into memory until you identify the cause, repair the cable and clear the fault from the ECU.

What is an intermittent fault?

An **intermittent** fault is a problem that usually occurs only under certain driving conditions. For example, the ECU may detect a loose cable or wire or receive an erratic signal from a wheel sensor. Since intermittent faults can be unpredictable and may only happen periodically, you can use information stored in ECU memory to find and correct the loose cable or wire. An intermittent fault cannot be retrieved using blink codes.

Is an intermittent fault difficult to locate and repair?

It can be, because you may not be able to easily see the cause of the problem. Meritor WABCO recommends that you write down intermittent faults to help you isolate a fault that recurs over a period of time.

Can the ECU store more than one fault in memory?

Yes. And the ECU retains existing and intermittent faults in memory even when you turn OFF the power to the ECU.

What if the ECU finds a fault in an ABS component during normal operation?

If the ECU senses a fault in the system (with an ABS valve, for example), the ECU turns the trailer ABS indicator lamp on and returns the wheel controlled by that valve to standard braking. Or, if the ECU finds a fault with one wheel speed sensor in a system that has four sensors on a tandem axle, the ECU uses information from the other sensor on the same side of the tandem to ensure continuous ABS function. The ECU continues to provide full ABS function to the wheels unaffected by system faults. However, the ECU will turn the trailer ABS indicator lamp on to tell the driver a fault has been detected in the system.

Enhanced Easy-Stop Installation Diagrams

With Enhanced Easy-Stop, Standard 2S/2M and Premium 2S/2M, 4S/2M and 4S/3M sensor location designations will change depending on how the ECU/dual modulator valve assembly is mounted. It may be mounted facing either the front or the rear of the trailer. It is important that you identify the location of these sensors before beginning any diagnostics. Sensor locations for both front and rear-facing installations are depicted in **Figures 4.1 through 4.10**.

NOTE: Sensor locations for the 2S/1M Basic will not change.

Configuration	Figure/Page
2S/1M Basic ECU	Figure 4.1/page 14
2S/2M Standard Mounted with Sensors Facing Front of Trailer	Figure 4.2/page 15
2S/2M Standard Mounted with Sensors Facing Rear of Trailer	Figure 4.3/page 16
2S/2M Premium Mounted with Sensors Facing Front of Trailer	Figure 4.4/page 17
2S/2M Premium Mounted with Sensors Facing Rear of Trailer	
4S/2M Premium Mounted with Sensors Facing Front of Trailer	Figure 4.5/page 18
4S/2M Premium Mounted with Sensors Facing Rear of Trailer	
4S/2M Premium – Typical Tri-Axle – Mounted with Sensors Facing Front of Trailer	Figure 4.6/page 19
4S/2M Premium – Typical Tri-Axle – Mounted with Sensors Facing Rear of Trailer	
4S/2M Premium – Typical Axle Control Installation – Mounted with Sensors Facing Front of Trailer	Figure 4.7/page 20
4S/2M Premium – Typical Axle Control Installation – Mounted with Sensors Facing Rear of Trailer	
4S/3M Premium – Typical Tri-Axle with Front Lift – Mounted with Sensors Facing Front of Trailer	Figure 4.8/page 21
4S/3M Premium – Typical Tri-Axle with Front Lift – Mounted with Sensors Facing Rear of Trailer	
4S/3M Premium – Typical Tri-Axle – Valve Mounted with Sensors Facing Front of Trailer	Figure 4.9/page 22
4S/3M Premium – Typical Tri-Axle – Valve Mounted with Sensors Facing Rear of Trailer	
4S/3M Premium – Typical Four Axle Pull Trailer – Valve Mounted with Sensors Facing Front of Trailer	Figure 4.10/page 23
4S/3M Premium – Typical Four Axle Pull Trailer – Valve Mounted with Sensors Facing Rear of Trailer	

Section 4 System Configurations

Typical Easy-Stop Trailer ABS installations are illustrated in Figure 4.1 through Figure 4.10:

NOTE: Meritor WABCO recommends placing sensors on the axle that will provide the most braking performance. The suspension manufacturer can provide this information.

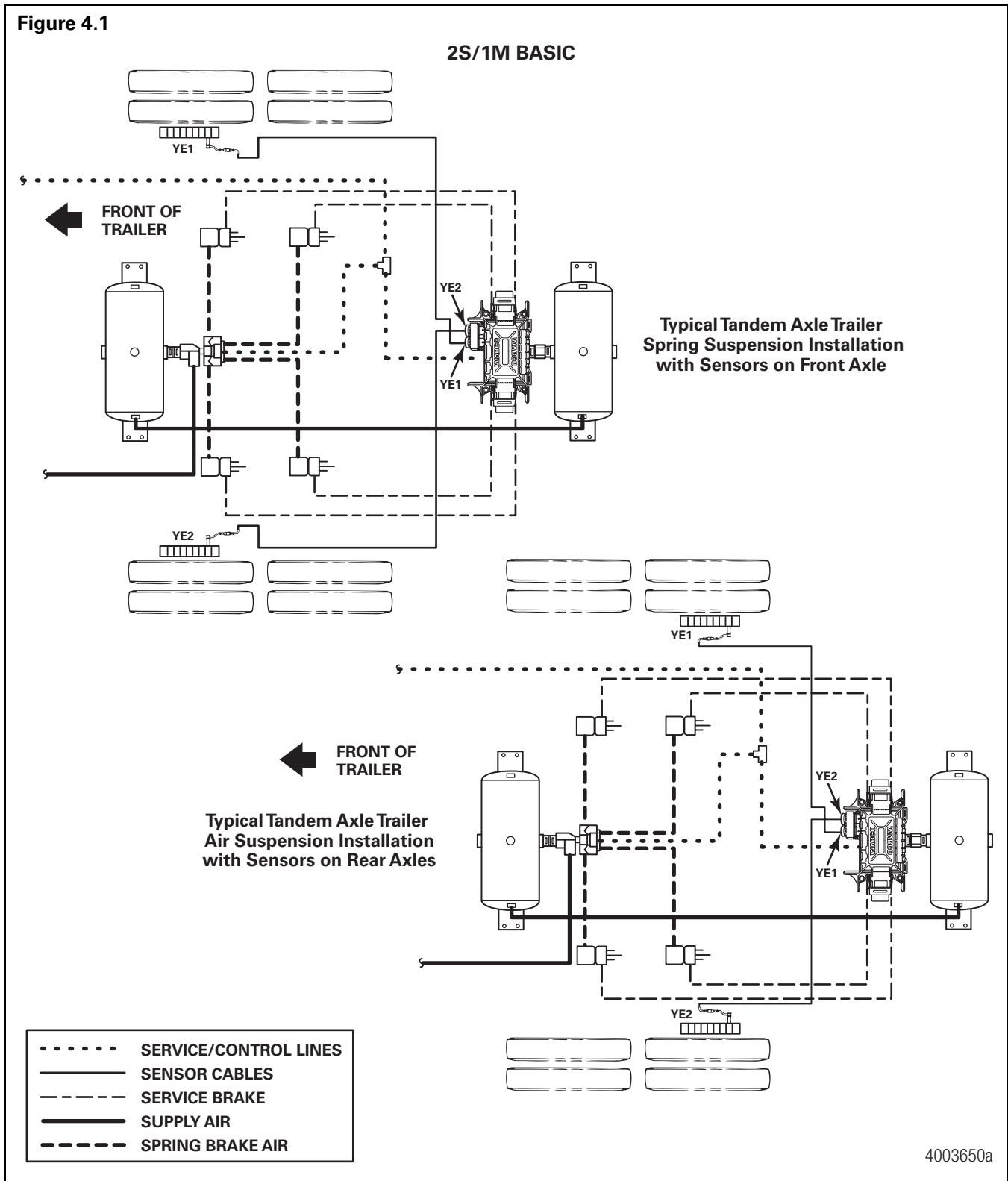

NOTE: Meritor WABCO recommends placing sensors on the axle that will provide the most braking performance. The suspension manufacturer can provide this information.

Figure 4.2

2S/2M STANDARD – MOUNTED WITH SENSORS FACING FRONT OF TRAILER

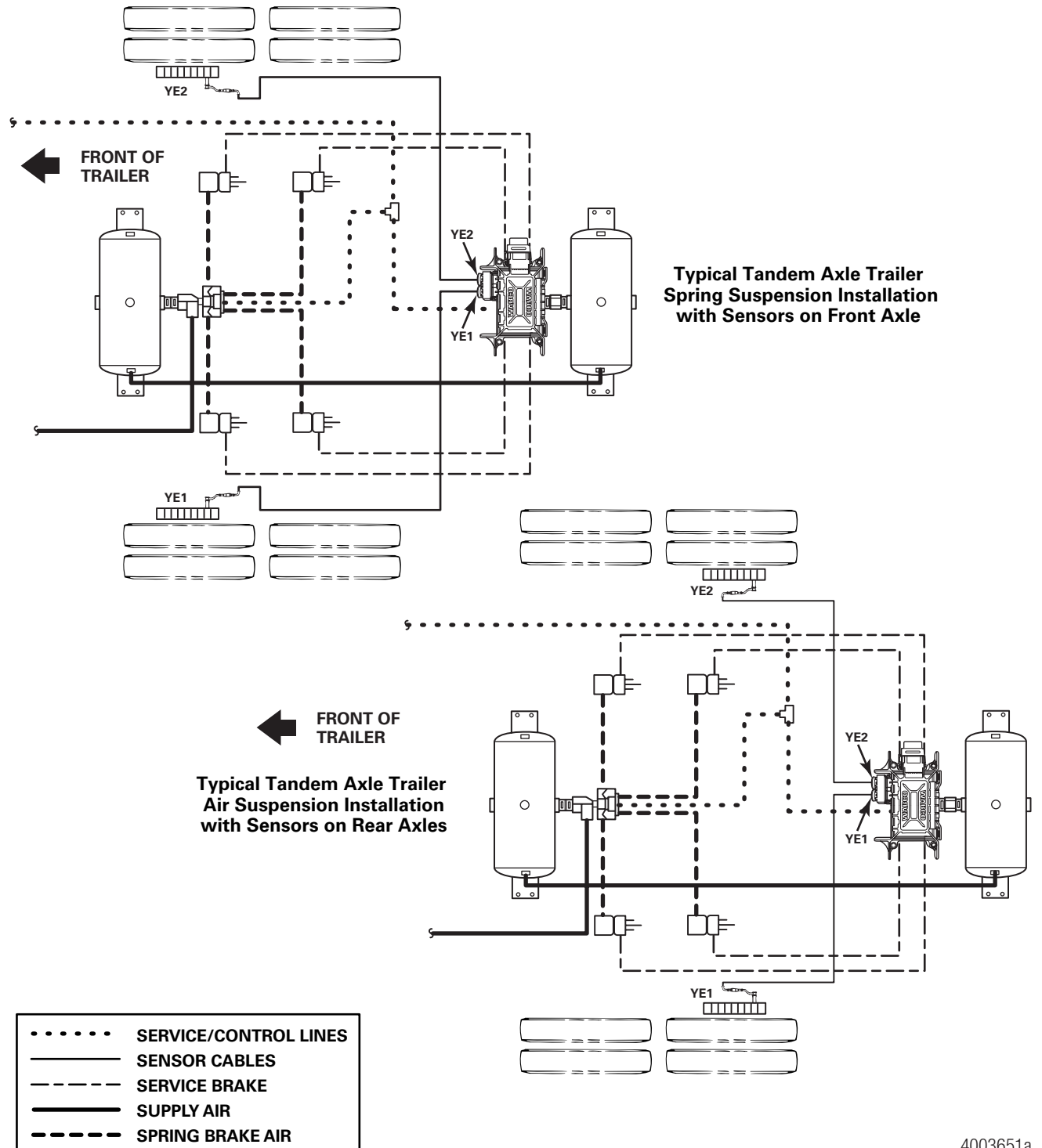

4003651a

Figure 4.3

2S/2M STANDARD — MOUNTED WITH SENSORS FACING REAR OF TRAILER

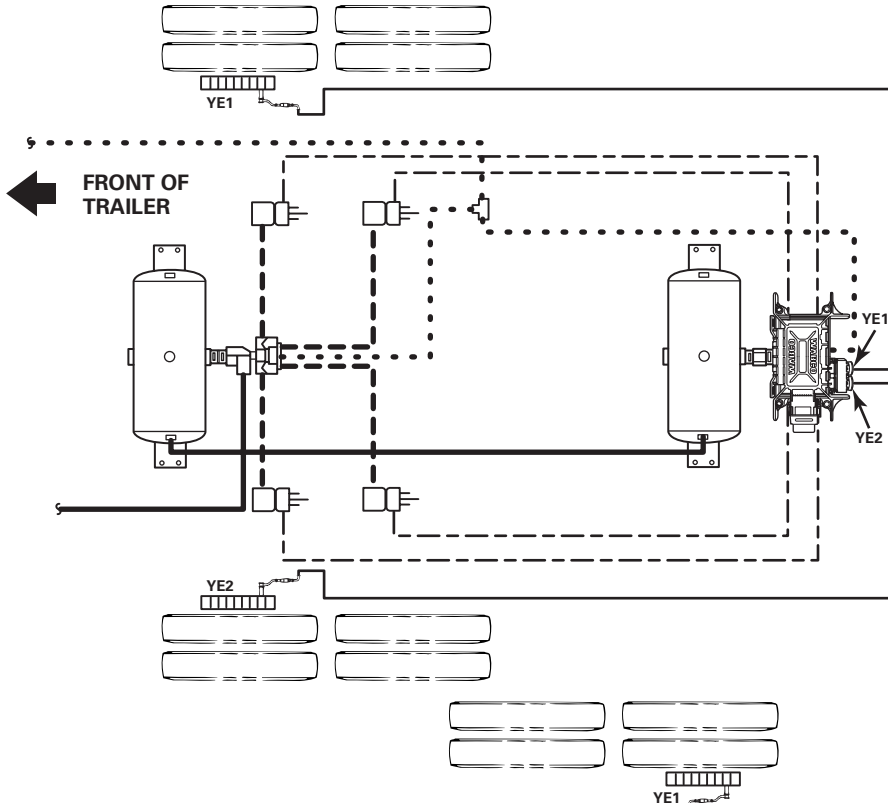

Typical Tandem Axle Trailer Spring Suspension Installation with Sensors on Front Axle

Typical Tandem Axle Trailer Air Suspension Installation with Sensors on Rear Axles

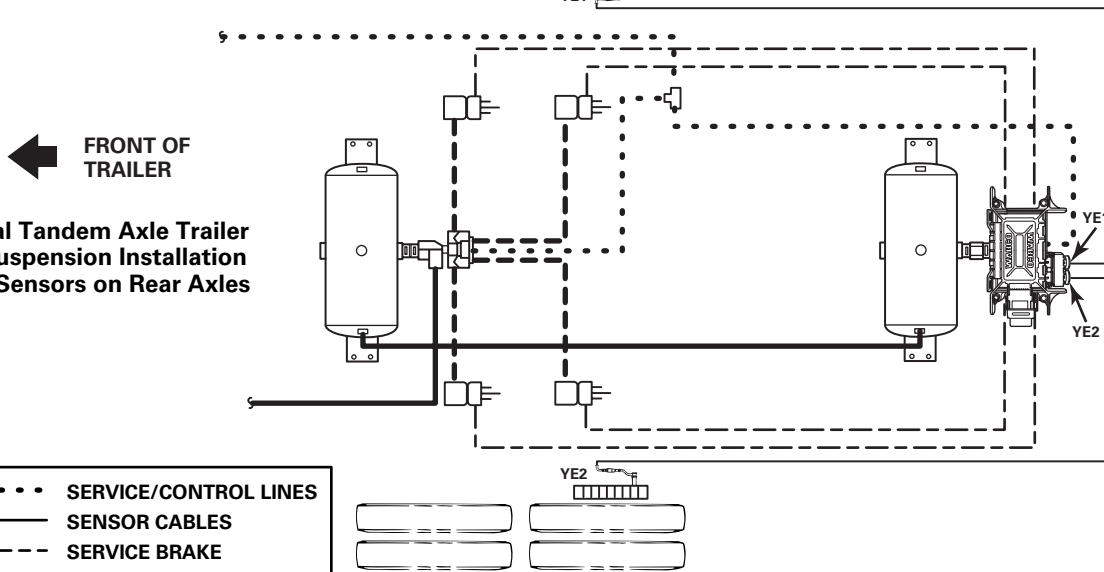

- • • • • SERVICE/CONTROL LINES
- SENSOR CABLES
- - - SERVICE BRAKE
- SUPPLY AIR
- - - SPRING BRAKE AIR

4003652a

NOTE: Meritor WABCO recommends placing sensors on the axle that will provide the most braking performance. The suspension manufacturer can provide this information.

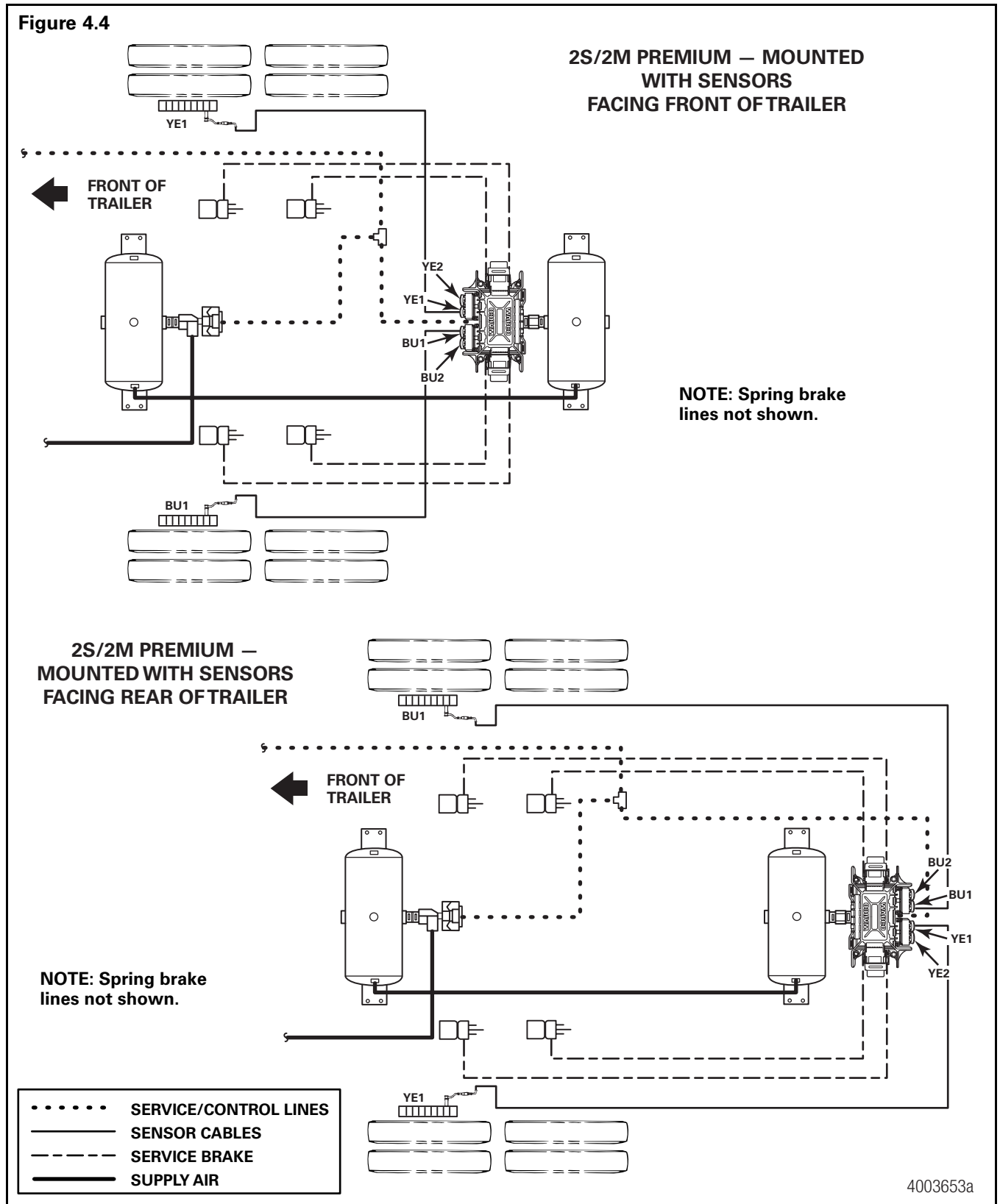

Section 4 System Configurations

NOTE: Meritor WABCO recommends placing sensors on the axle that will provide the most braking performance. The suspension manufacturer can provide this information.

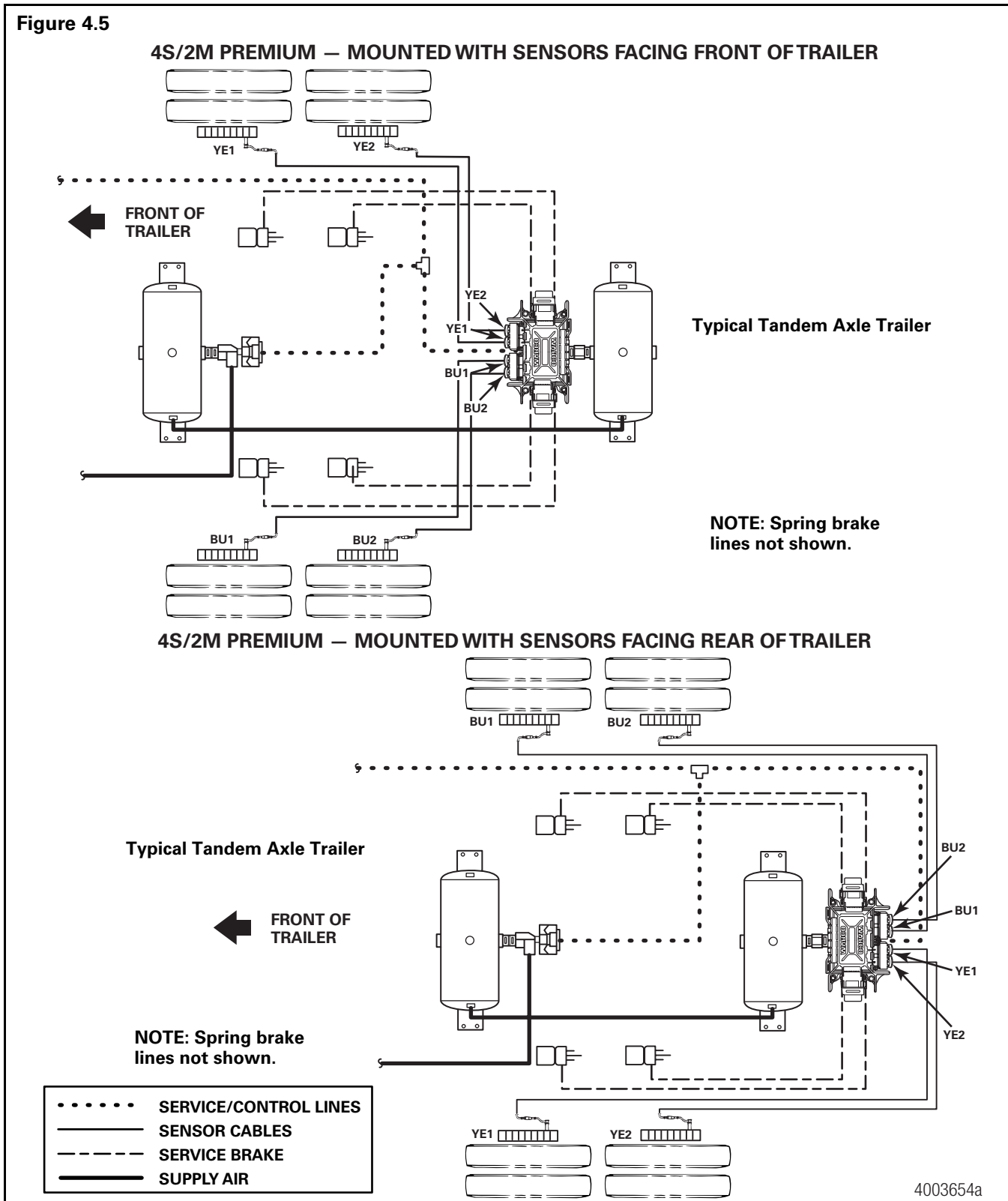
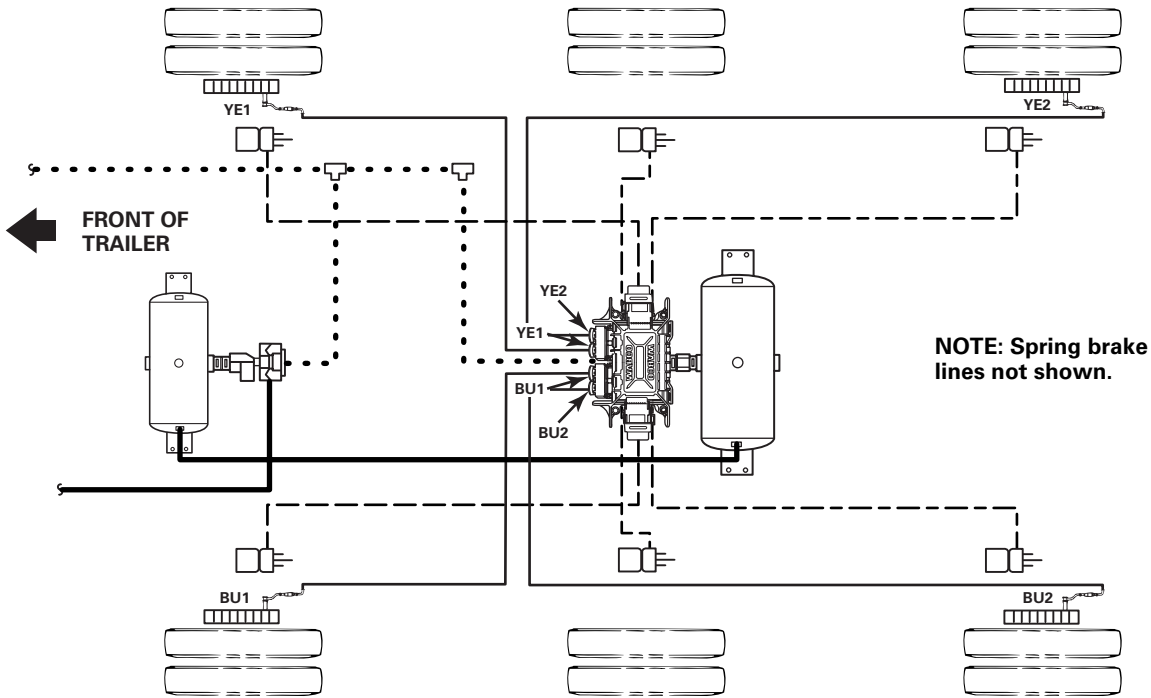
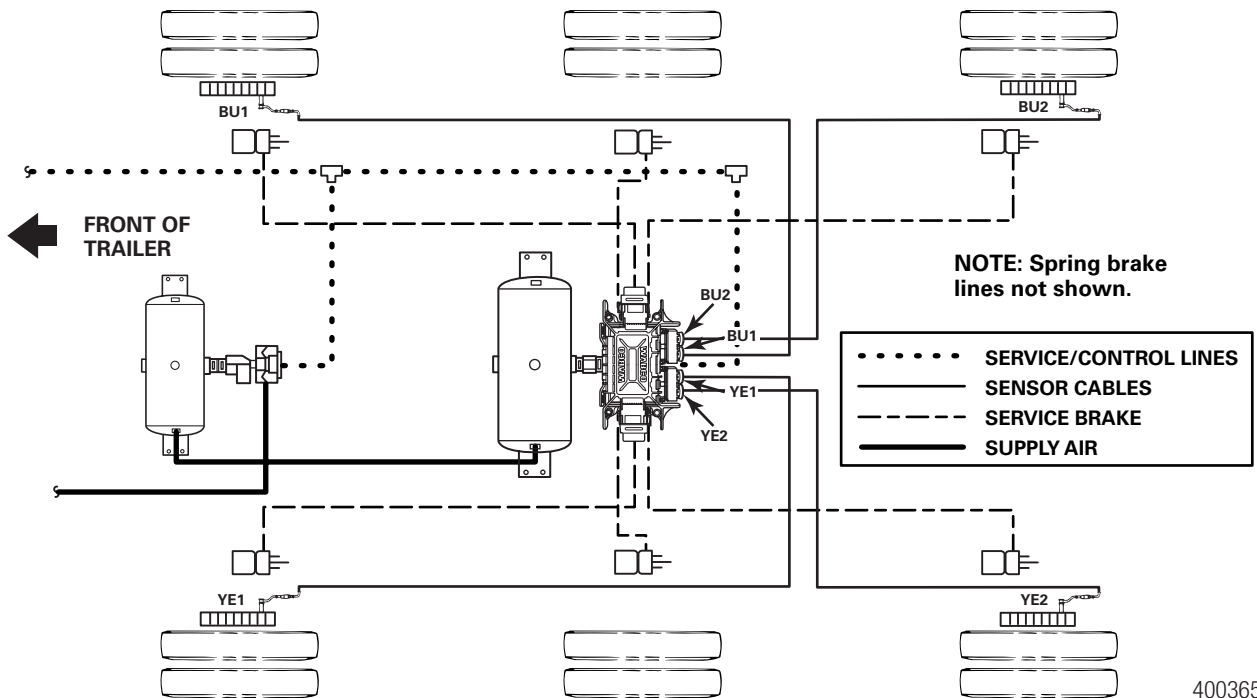

Figure 4.6

4S/2M PREMIUM – TYPICAL TRI-AXLE – MOUNTED WITH SENSORS FACING FRONT OF TRAILER



4S/2M PREMIUM – TYPICAL TRI-AXLE – MOUNTED WITH SENSORS FACING REAR OF TRAILER



4003655a

Figure 4.7

4S/2M TYPICAL AXLE CONTROL INSTALLATION – VALVE MOUNTED WITH SENSORS FACING FRONT OF TRAILER

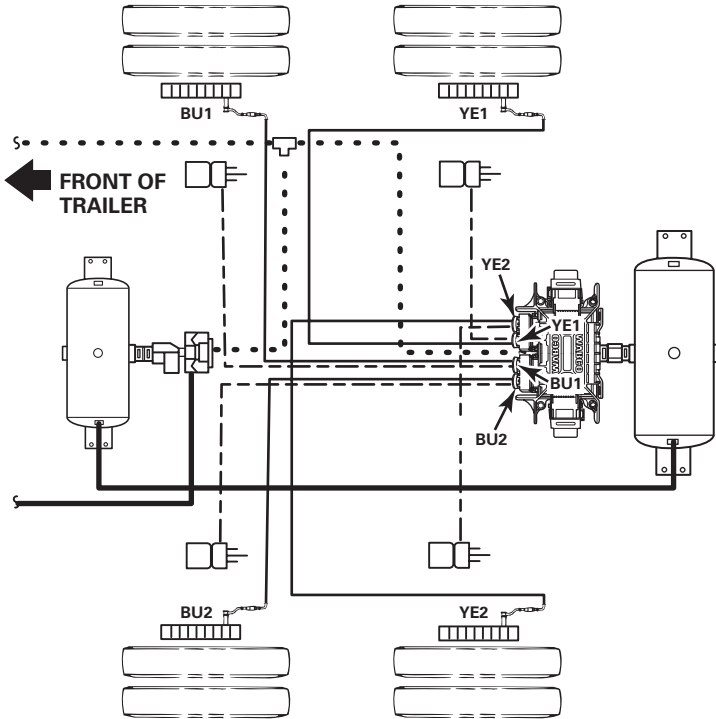

4S/2M TYPICAL AXLE CONTROL INSTALLATION – VALVE MOUNTED WITH SENSORS FACING REAR OF TRAILER

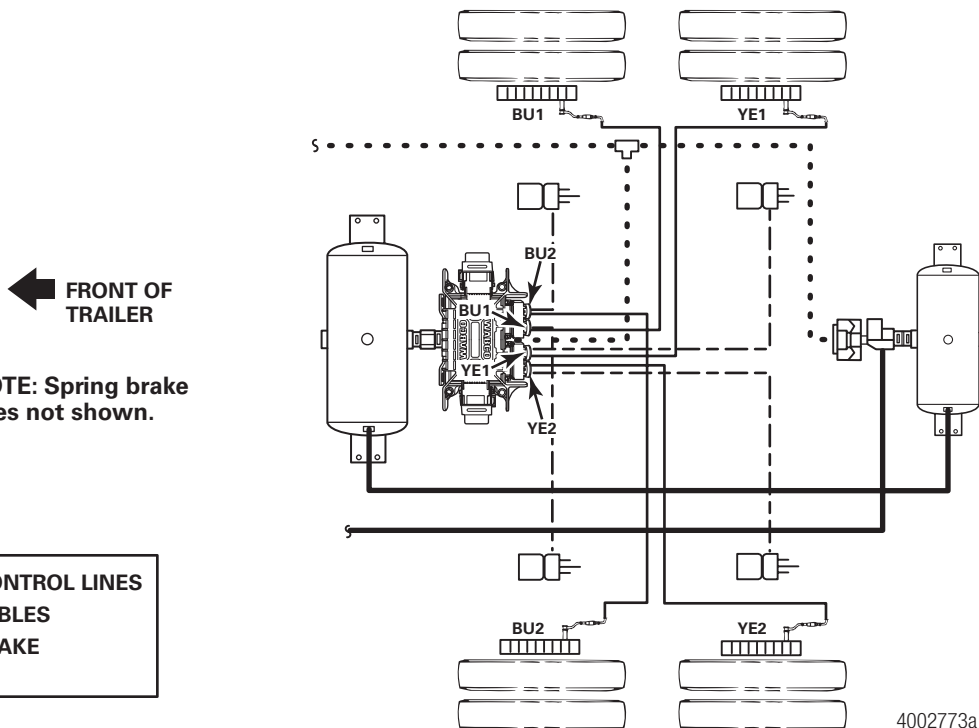

- SERVICE/CONTROL LINES
- SENSOR CABLES
- SERVICE BRAKE
- SUPPLY AIR

4002773a

Figure 4.8

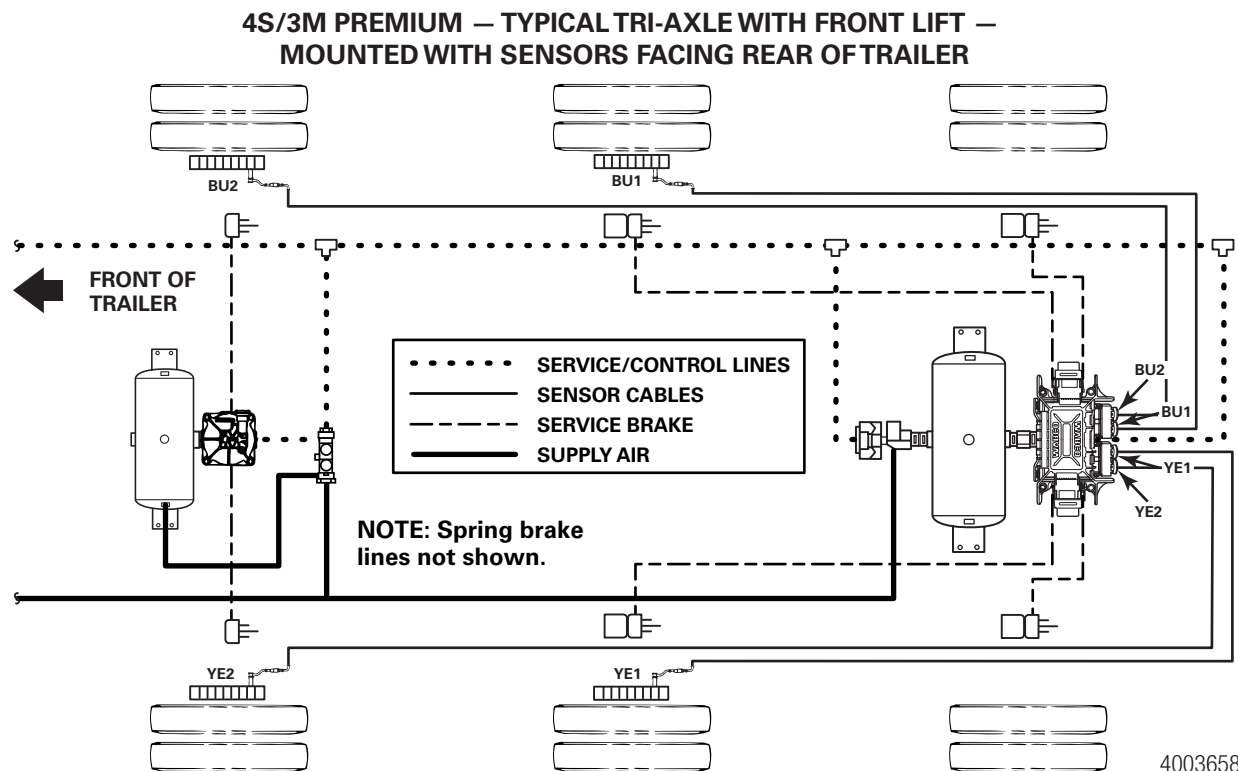
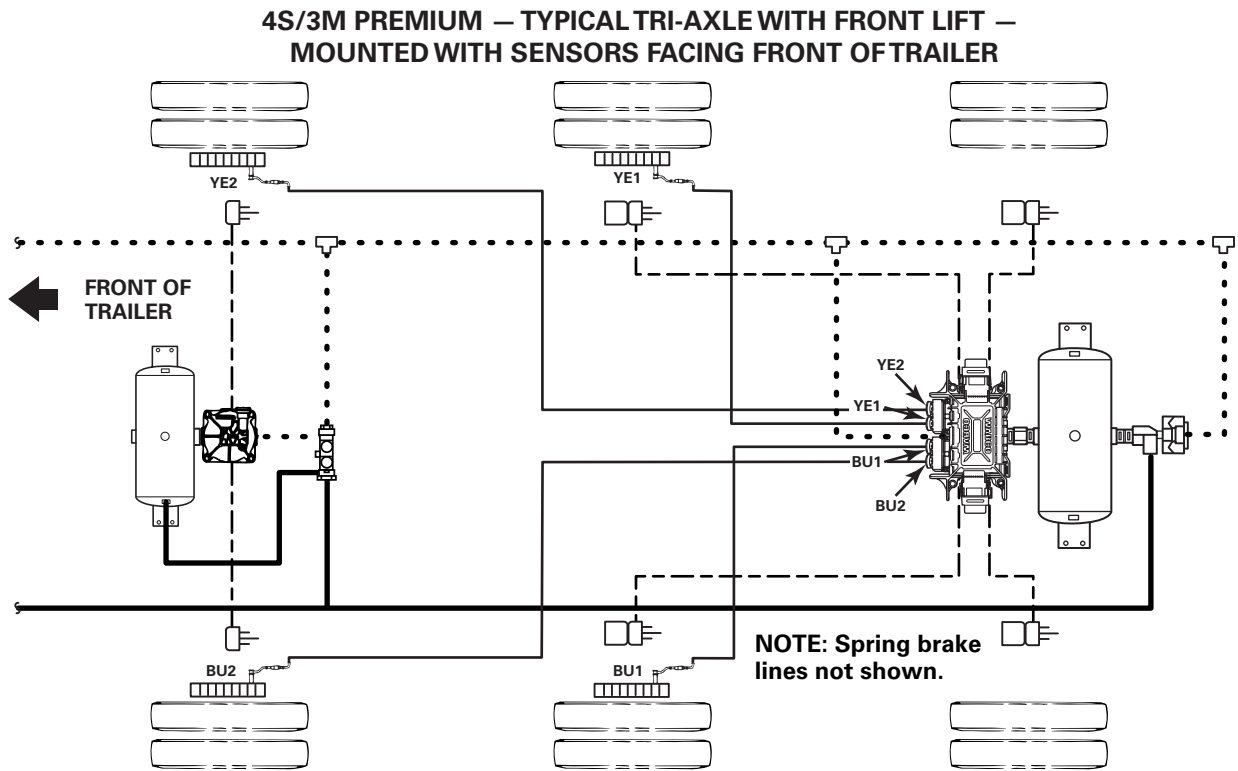

4003658a

Figure 4.9

4S/3M PREMIUM – TYPICAL TRI-AXLE – MOUNTED WITH SENSORS FACING FRONT OF TRAILER

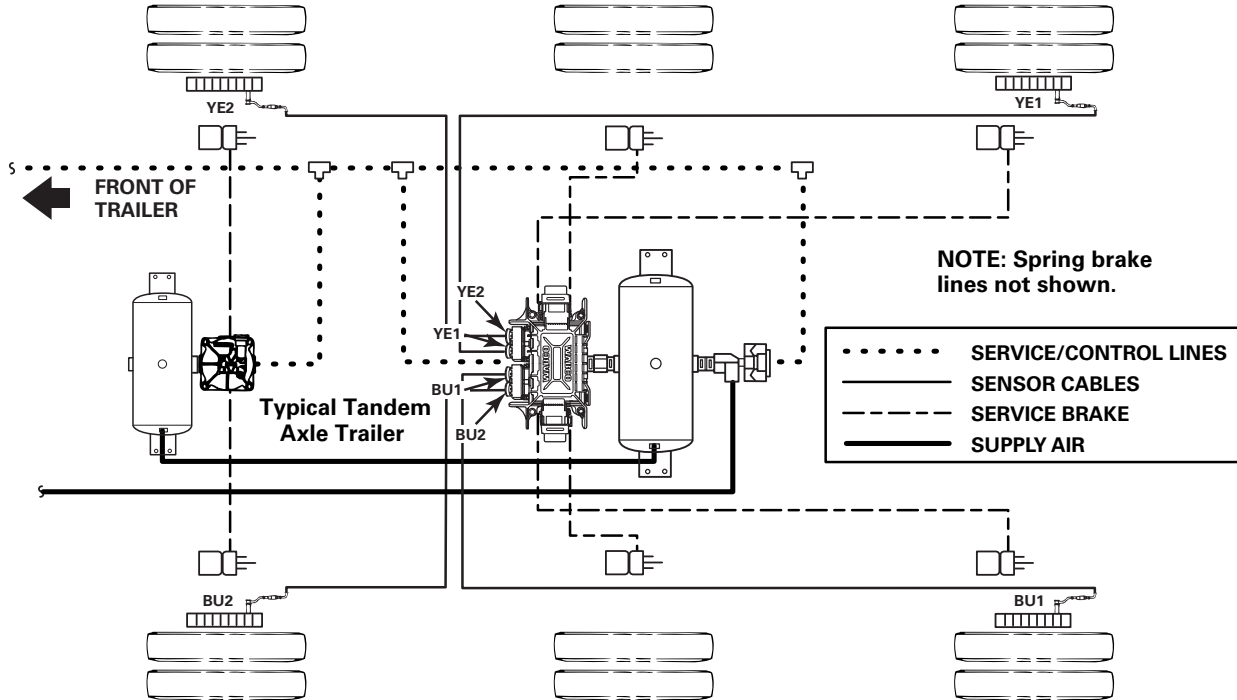

4S/3M PREMIUM – TYPICAL TRI-AXLE – MOUNTED WITH SENSORS FACING REAR OF TRAILER

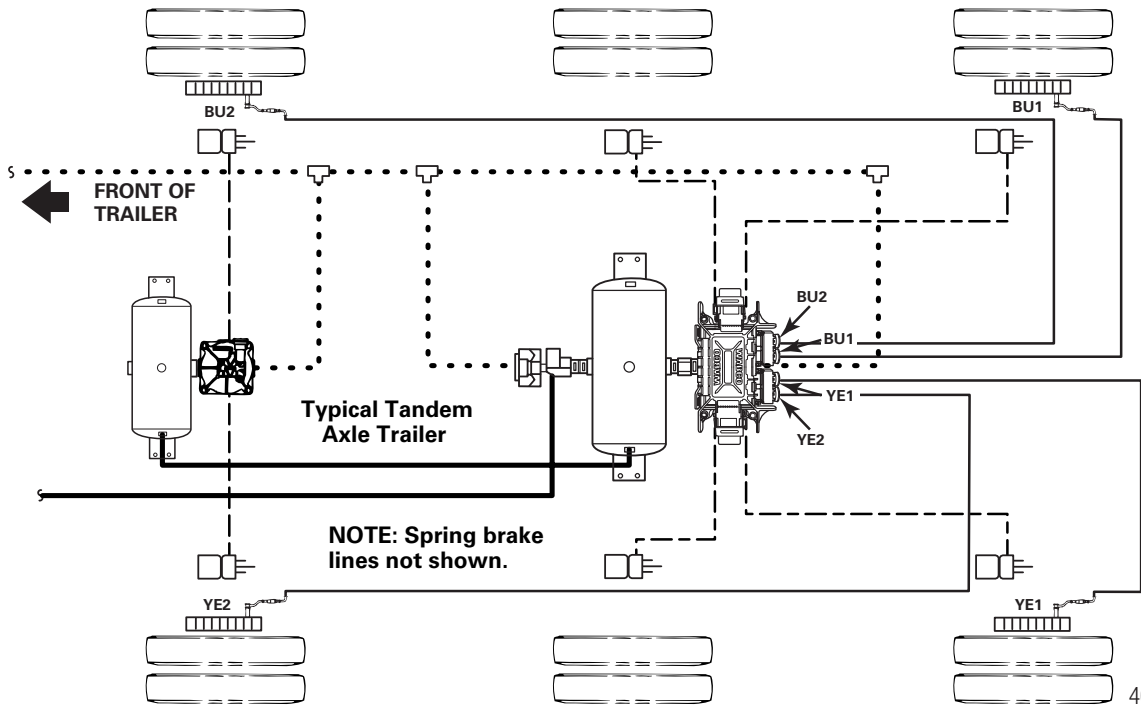

4003659a

Figure 4.10

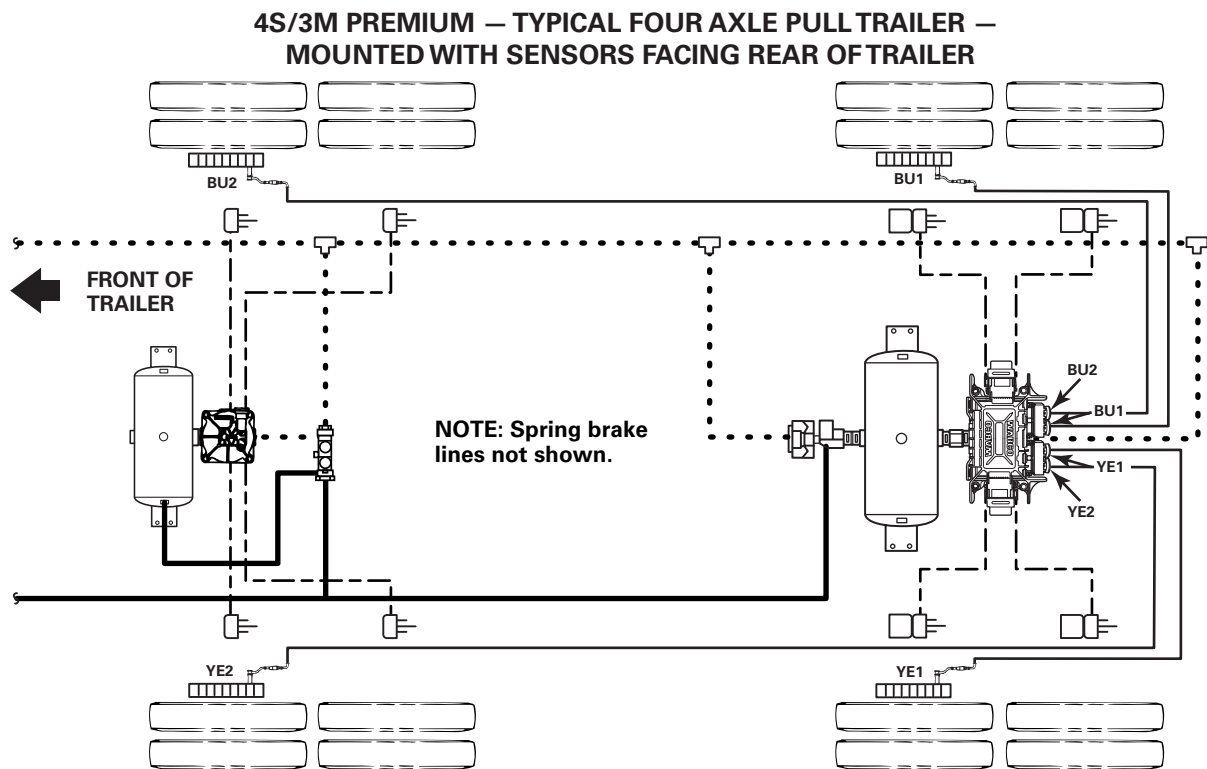
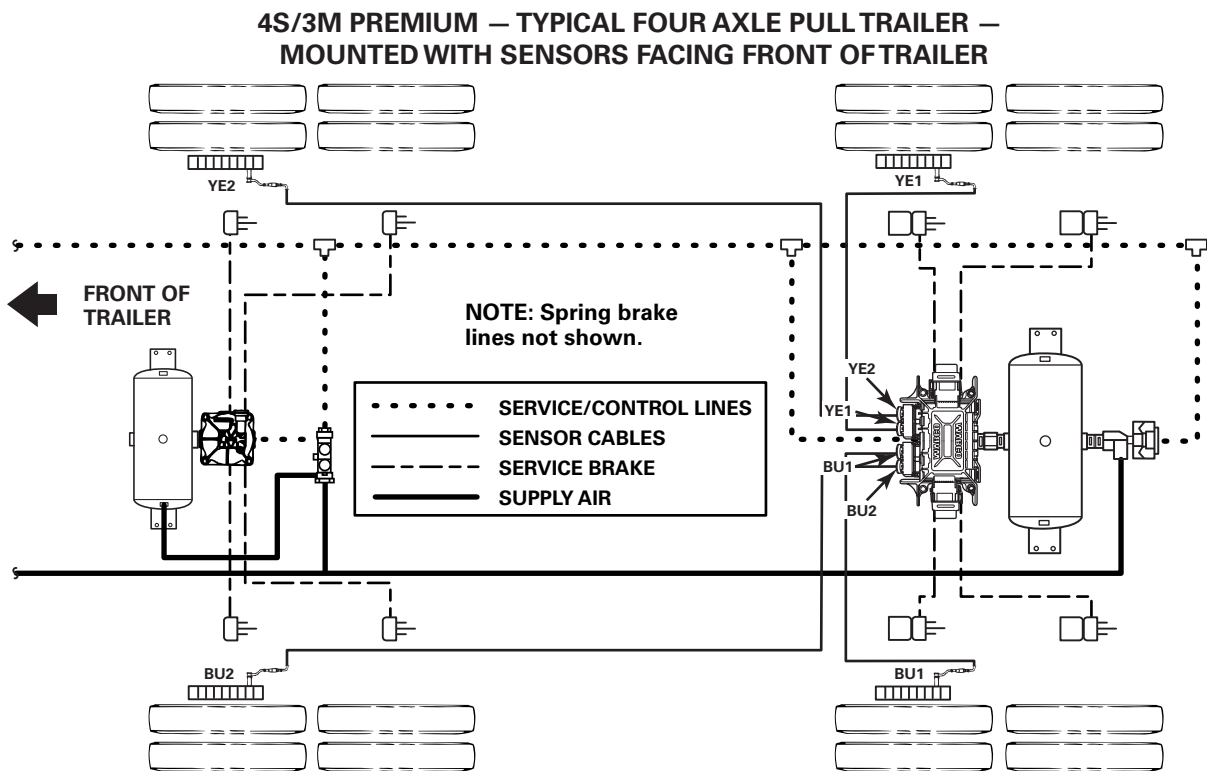

4003660a

Power Cable Wiring Diagrams

Figure 4.11

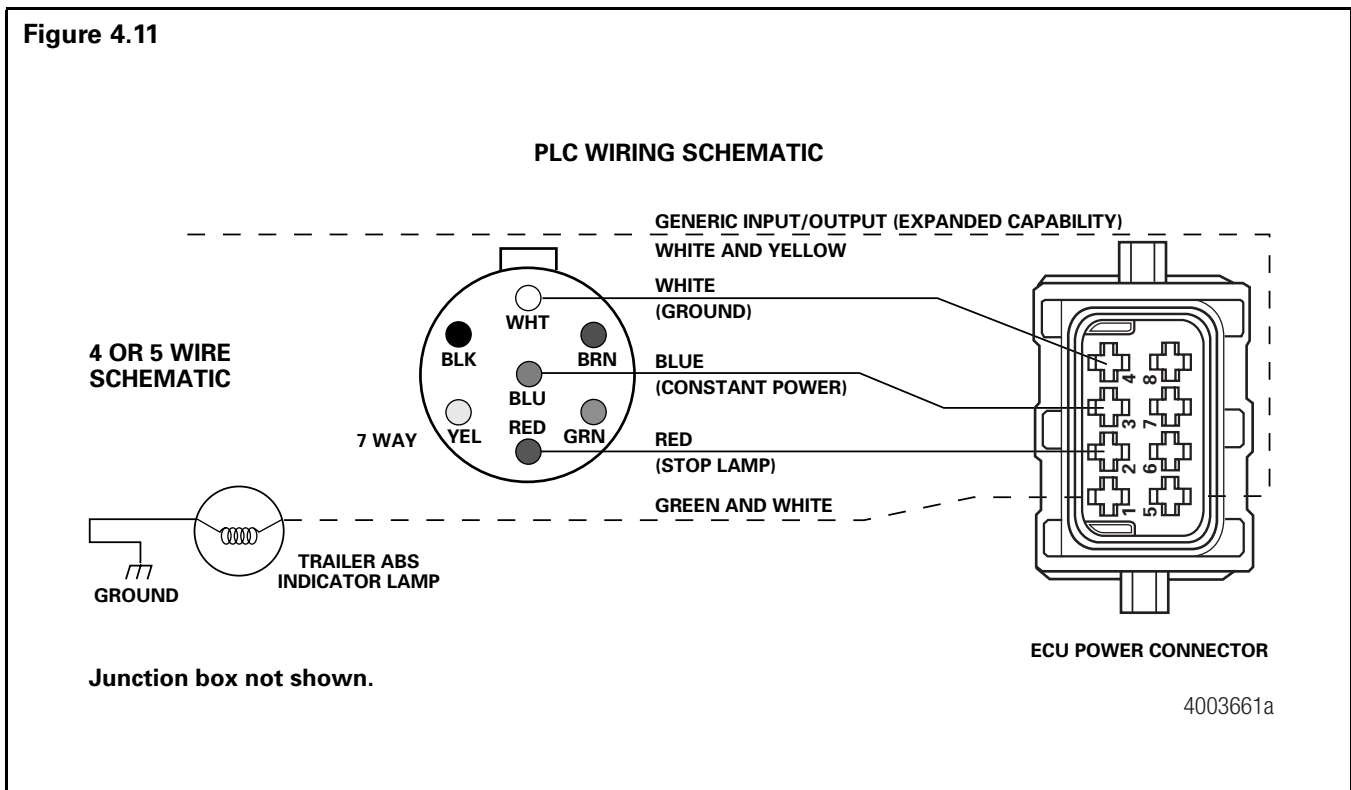

⚠ WARNING

To prevent serious eye injury, always wear safe eye protection when you perform vehicle maintenance or service.

The ABS is an electrical system. When you work on the ABS, take the same precautions that you must take with any electrical system to avoid serious personal injury. As with any electrical system, the danger of electrical shock or sparks exists that can ignite flammable substances. You must always disconnect the battery ground cable before working on the electrical system.

Diagnostics

There are three methods used to get fault information from the ECU:

- TOOLBOX Software
- Pro-Link 9000
- Blink code diagnostics
 - Ignition power activation
 - Diagnostic tool

There is also a new diagnostic tool for checking PLC, the PLC/J1708 adapter. **Figure 5.1.**

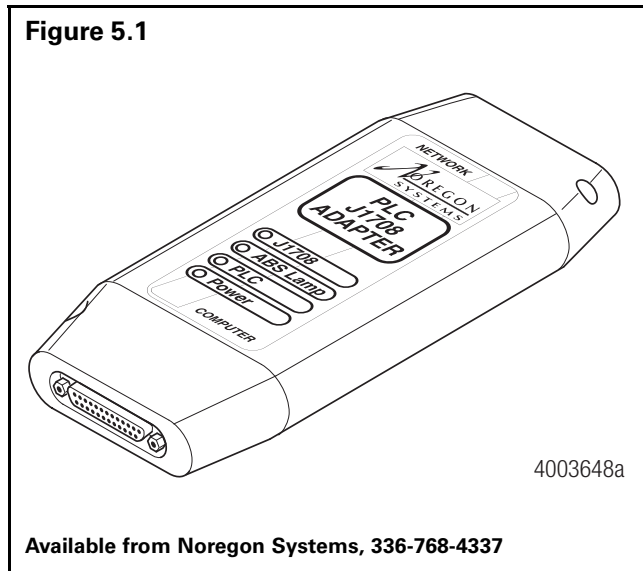

Important PLC Information for Blink Code Diagnostics

Blink Code 17 indicates a PLC failure. If PLC does not seem to be operating properly, but there is no Blink Code 17, the ECU is functioning properly and does not need to be replaced; however, there could be a problem in the trailer's wiring harness. Check the wiring system and make the necessary repairs. If the problem persists, contact the customer service center for assistance.

TOOLBOX Software

Meritor WABCO TOOLBOX Software is a PC-based diagnostic program. Version 4.1 (or higher) runs in Windows® 95, 98, NT, 2000 or Me and provides diagnostic capabilities by communicating with the ECU. Trailer ABS screens are described in this manual. Refer to the owner's manual for detailed operating instructions.

TOOLBOX Software has the following functions.

- Supports Enhanced Easy-Stop with PLC.
- Displays both constant and changing information from the ECU being tested.
- Displays both active and stored system faults, as well as the appropriate repair instructions.
- Activates system components to verify:
 - System integrity
 - Proper component operation
 - Installation wiring

NOTE: A J1587/J1708 to RS232 or PLC to J1708 interface is required to run this software.

TOOLBOX Software is available from SPX (Kent-Moore), 800-345-2233.

Main Screen

Figure 5.2

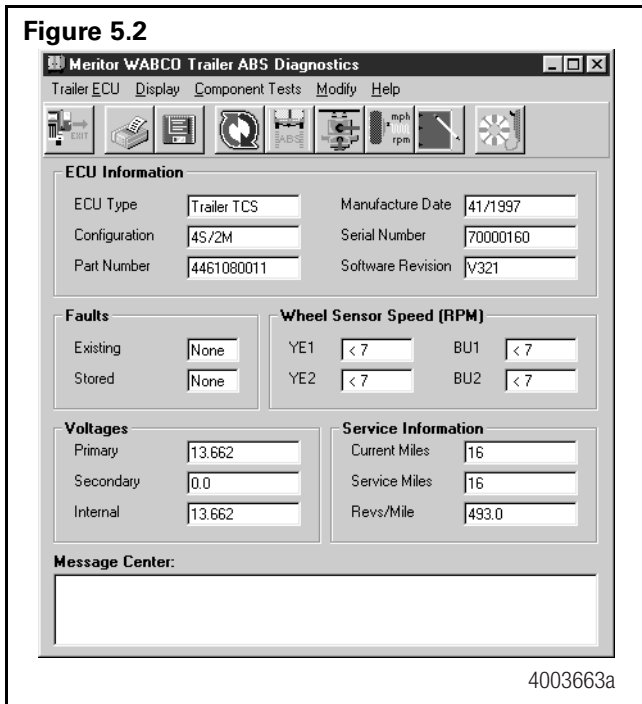

This screen provides icon and pull-down menu task selections. It also provides information about the current state of the Meritor WABCO Enhanced Easy-Stop Trailer ABS. ECU information is read once from the ECU and does not change. Wheel speed, voltages, faults and information are read and updated continuously.

In the Service Information field, the ECU, working with a constant powered tractor, can act as a mileage counter. This field can also be used to set service intervals. **Figure 5.2.**

Tire Calibration

Figure 5.3

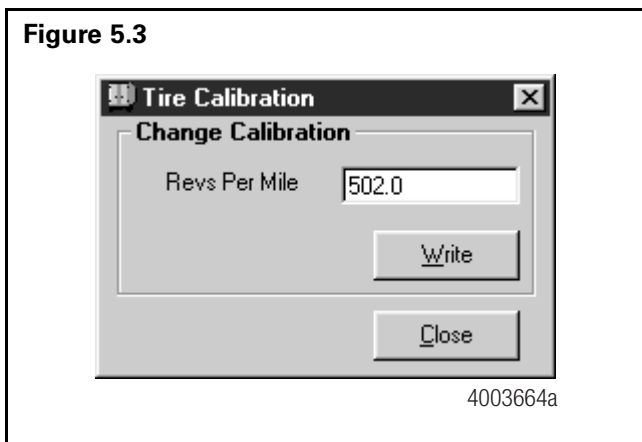

The programmed number of tire Revs Per Mile is displayed on the Tire Calibration screen. Range is 150.0 to 634.0 rpm. The default value is 502.0. To change this value, type in the Revs Per Mile, then press the Write button. **Figure 5.3.**

NOTE: Trailers with 12-1/4" brakes use an 80-tooth tone ring (tooth wheel). Use a value of 80% of the tire manufacturers recommended revolutions per mile (Revs Per Mile X 0.80).

Service Information

Figure 5.4

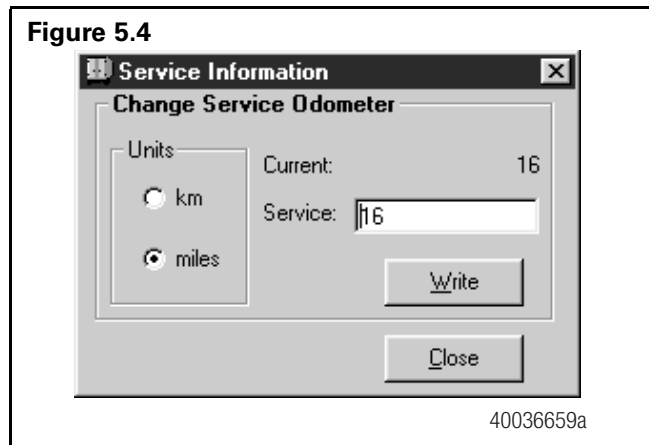

The mileage between scheduled maintenances is displayed on the Service Information screen in km or miles.

When the mileage displayed elapses, the Enhanced Easy-Stop Trailer ABS indicator lamp on the side of the trailer will flash eight times. It will continue to flash eight times whenever the ignition switch is turned on until this parameter is changed. **Figure 5.4.**

Notebook

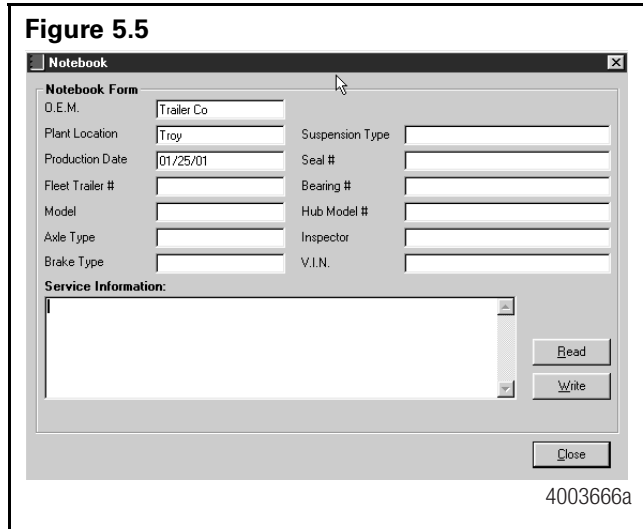

The Notebook Form field of this screen is used to store and review information about a specific vehicle. **Figure 5.5.**

Sensor Test

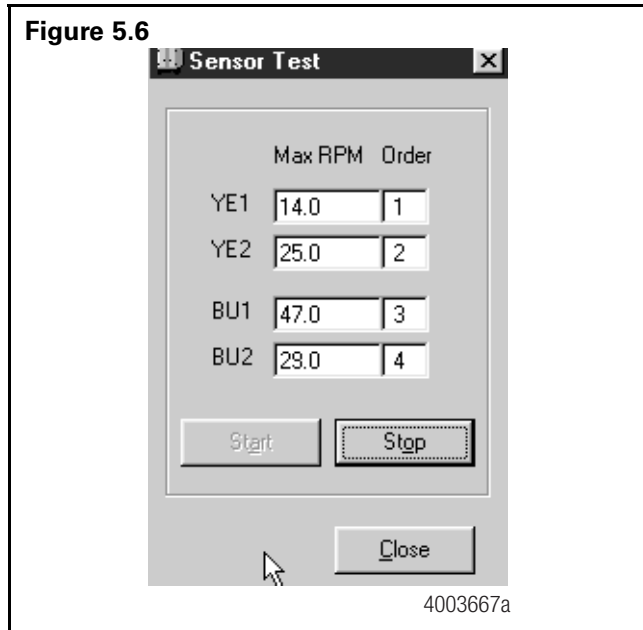

The Sensor Test screen is used to determine the correct installation, wiring and functionality of the wheel speed sensors.

The screen display will provide maximum sensor RPM for installed sensors (unused sensor positions will be grayed out). Check the order field to verify sensors are installed in the correct location.

Figure 5.6.

Report Information

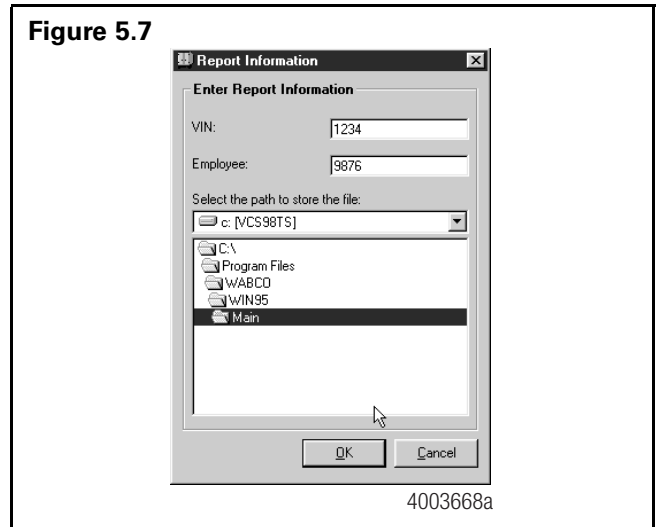

The Report Information screen allows the user to store and retrieve information about a specific vehicle, including the Vehicle Identification Number (VIN) and Employee numbers. **Figure 5.7.**

An example of a storable (or printable) report is displayed in **Figure 5.8.**

Meritor WABCO ABS Fault Report

Figure 5.8

Meritor WABCO ABS Fault Report

Date: September 13, 2000
Time: 5:25 PM
Page: 1
VIN: 12345678
Employee Information: KILEY
ABS System Configuration: 4S/2M
ECU Revision: V 3 2 2 ' ' ' '
Part Number: 446-108-000-1
Serial Number: 5 9 3 0 3 9 4 8 ' ' ' ' ' ' ' ' ' '
Date of Manufacture: 13/1999'
Current Miles: 0.0
Service Miles: 0.0
Tire Calibration: 495.0

Fault #	Description	Status	SID	FMI	Count
1	Ext. modulator BLUE open circuit detected	Active	9	5	1
2	Ext. modulator BLUE open circuit detected	Stored	9	5	1

Sensor Test Results:

Sensor	Max RPM	Order
YE1	40.0	1
YE2	59.0	2
BU1	50.0	3
BU2	38.0	4

Valve Tests Performed:

Valve	Status (Tested / Not Tested / NA)
Yellow	Tested
Blue	Tested
Red	N/A

4003669a

Save and Print

1. Click on the heading Trailer ECU and click Save. A window will appear asking for the VIN and Employee number.
2. Provide this information and close the window.
3. Go back to the heading Trailer ECU and click Print.
4. You will be asked to input the VIN and Employee number.
5. Click Print.

Blink Code Diagnostics

The Meritor WABCO Enhanced Easy-Stop Trailer ABS ECU detects any electrical fault in the trailer ABS. Each of the faults has a code. When a fault occurs, the ECU stores the code for that fault in the memory.

There are two kinds of faults: active and stored. Active faults are those currently existing in the system, such as a broken wire. Stored faults are faults that have occurred but do not presently exist. Active faults can be cleared only after repairs are completed. Stored faults can only be diagnosed with TOOLBOX Software or the Pro-Link® 9000.

The ECU signals a malfunction by lighting both the internal and external indicator lamp when a fault exists. The external ABS indicator lamp is usually mounted on the left rear of the trailer, near the rear wheels.

There are two ways to obtain blink codes:

- Ignition Power Activation (recommended method)
- Diagnostic Tool

NOTE: In previous versions of Easy-Stop, the blink code tool and the ABS indicator lamp would flash the blink code at the same time. With Enhanced Easy-Stop, this does not happen. The codes are displayed one blink at a time, first on the trailer ABS lamp, then on the blink code tool, as illustrated in **Figure 5.9**.

Although the ECU can store multiple faults in its memory, it only displays one blink code at a time. This is why it is important to recheck the blink codes after repairing a fault. If there are additional codes in the memory, they only blink after you have repaired the first fault.

Stored faults, clear all and end of line test modes are available with the TOOLBOX Software or the Pro-Link 9000.

Ignition Power Activation

Ignition Power Activation is the process of using the vehicle’s ignition switch (or interrupting the power on the blue wire by some other means) to display blink codes on the trailer ABS indicator lamp located on the side of the trailer. This method is for constant power vehicles only.

To obtain blink codes using ignition power activation, perform the following procedure:

1. Turn the ignition switch on for no longer than 5 seconds. The ABS indicator lamp will be on.
2. Turn the ignition switch off. The ABS indicator lamp will go out.
3. Turn the ignition switch on. The ABS indicator lamp will then come on, then go out.
4. The blink code will be displayed three times by the ABS indicator lamp on the trailer.

NOTE: For ignition power activation, power is provided by the ignition switch.

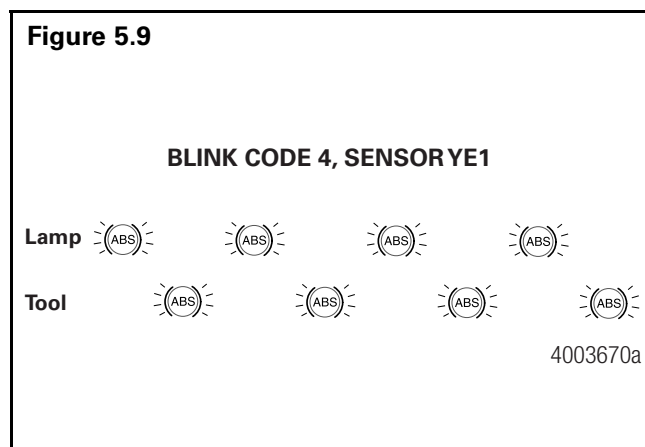

Table C: Blink Codes

BLINK CODES		
Blink Code	Problem Area	Action
3	Sensor BU1	Determine sensor location. Check sensor installation. Make necessary repairs.
4	Sensor YE1	Determine sensor location. Check sensor installation. Make necessary repairs.
5	Sensor BU2	Determine sensor location. Check sensor installation. Make necessary repairs.
6	Sensor YE2	Determine sensor location. Check sensor installation. Make necessary repairs.
7	External ABS modulator valve	Verify proper electrical installation. Check power supply. Make necessary corrections.
9	Internal modulator failure, inlet valve #2	Verify proper installation. If code continues, contact Meritor WABCO for assistance.
10	Internal modulator failure, inlet valve #1	Verify proper installation. If code continues, contact Meritor WABCO for assistance.
11	Internal modulator failure, outlet valve	Verify proper installation. If code continues, contact Meritor WABCO for assistance.
14	Power Supply	Verify proper electrical installation. Check power supply. Make necessary corrections.
15	ECU Failure	Verify proper installation. If code continues, contact Meritor WABCO for assistance.
16	SAE J1708 Failure	Internal failure, contact Meritor WABCO.
17	SAE J2497 (PLC) Failure	Internal failure, contact Meritor WABCO.
18	Generic I/O Failure	Verify proper electrical installation. Check power supply. Make necessary corrections.

Diagnostic Tool (Blink Code Check)

The red dust cap on the diagnostic tool protects the tool during shipping. The tool and the LED are independently sealed against contamination.

The SAE J1587 connector must be protected from contamination when the diagnostic tool is not installed. Reinstall the gray cap when the connector is not in use.

Use the following procedures to install the diagnostic tool in the SAE J1587 connector.

1. Remove the gray protective cap from the J1587 connector.
 - Turn the cap counterclockwise.
 - Pull off the cap.
2. Align the notches on the tool with the notches on the connector.
3. Insert the tool firmly in the connector.
4. Firmly turn the gray ring of the tool clockwise to secure it in place. **Figure 5.10.**
5. After removing the diagnostic tool, replace the gray protective cap.

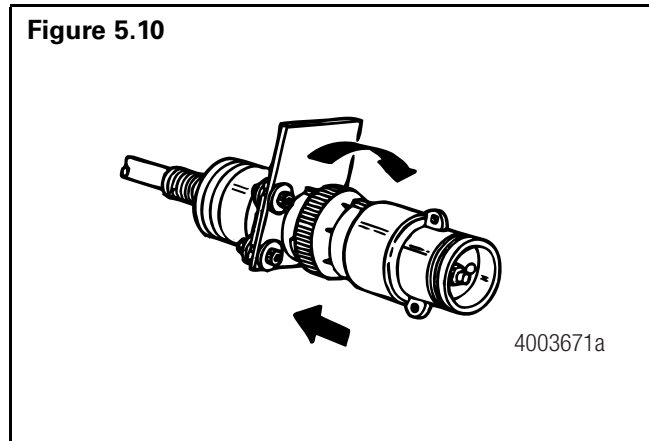

6. Make sure the vehicle is stationary:
 - Emergency brake ON
 - Wheels properly chocked
7. Provide 12 volts DC power (9.5 to 14 volts is acceptable range) to the ECU/Valve Assembly.

8. Check the ABS indicator lamp on the trailer. If:
 - The indicator lamp comes ON briefly, then goes OFF: There is no fault in system.
 - The indicator lamp comes ON and stays ON: There is an existing fault. Go to Step 9.
9. Press the blink code switch **once** for **one second** and release the switch.
10. **When there is an existing fault:** The ABS indicator lamp will flash between **three** and **eighteen** times to identify the existing fault.
11. **When there are existing faults:** You must repair existing faults.
12. After you identify an existing fault, turn the power to the ECU **OFF**. Repair the fault. Turn the power to the ECU back **ON**.
13. Repeat Step 9. If there are no other existing faults in the system, the ABS indicator lamp will come **ON**, go **OFF** and remain **OFF**.
14. If you have just repaired a sensor gap fault, the ECU is "waiting" to see a 4-mph signal on sensed wheels. Until this 4 mph is sensed by the ECU, the ABS indicator lamp on the trailer will remain **ON**.

SPX (Kent-Moore) offers Kit J 38500-404 that contains the Meritor WABCO ABS Multiple Protocol Cartridge (MPC), a Meritor WABCO applications card, and the manual *Meritor WABCO ABS/ATC Systems*, which contains complete information and operating instructions for the MPSI Pro-Link 9000 diagnostic tool. Order the kit from SPX (Kent-Moore), 28635 Mound Road, Warren, MI 48092-3499; phone 800-345-2233.

NOTE: A J 38500-60A Deutsch cable is also required. It is available from SPX (Kent-Moore).

MPSI Pro-Link 9000 Diagnostic Tool

The MPSI Pro-Link 9000 diagnostic tool can test for existing and stored faults, read and clear fault codes, and test components, for Meritor WABCO tractor and trailer ABS.

⚠ WARNING

To prevent serious eye injury, always wear safe eye protection when you perform vehicle maintenance or service.

Park the vehicle on a level surface. Block the wheels to prevent the vehicle from moving. Support the vehicle with safety stands. Do not work under a vehicle supported only by jacks. Jacks can slip and fall over. Serious personal injury can result.

The ABS is an electrical system. When you work on the ABS, take the same precautions that you must take with any electrical system to avoid serious personal injury. As with any electrical system, the danger of electrical shock or sparks exists that can ignite flammable substances. You must always disconnect the battery ground cable before working on the electrical system.

NOTE: Disconnect power from the ECU/Valve Assembly before you remove any components. Failure to disconnect power from the ECU can cause faults to be recorded and stored in ECU memory.

⚠ CAUTION

When welding on an ABS-equipped vehicle is necessary, disconnect the power connector from the ECU to avoid damage to the electrical system and ABS components.

⚠ CAUTION

High voltages can damage the electronic control unit (ECU). Disconnect all connectors from the ECU before you perform any welding, electrostatic painting, or any other activity that applies high voltage to the vehicle frame. Install blind plugs into the ECU to protect the connector openings. Ground the welding or painting equipment to the part you are working on. If you are working on a moving or insulated component such as an axle, make sure it is correctly grounded through the frame. Refer to the equipment manufacturer's recommended instructions for correct procedures.

Wheel Speed Sensor

How to Remove a Sensor

1. Follow the vehicle manufacturer's instructions to back off the slack adjuster and remove the tire, wheel and drum.

3. Hold the sensor, not the cable, and use a twisting motion to pull the sensor out of its mounting block.
3. Remove the spring clip from the mounting block.
3. Remove any fasteners that hold the sensor cable to other components.
3. Disconnect the sensor cable from the extension cable.

How to Install a Sensor

Sensor locations vary according to suspension types. Typically, a spring suspension has sensors on the forward axle, and an air suspension has sensors on the rear axle.

1. Apply a mineral oil-based grease that contains molydisulfide to the sensor spring clip and to the body of the sensor. The grease must be anti-corrosive and contain adhesive properties that will continuously endure temperatures from -40° to 300°F (-40° to 150°C).
3. Push the spring clip into the sensor holder from the inboard side, until the spring clip tabs are against the sensor holder. Push the sensor into the spring clip as far as possible.

Figure 6.1.

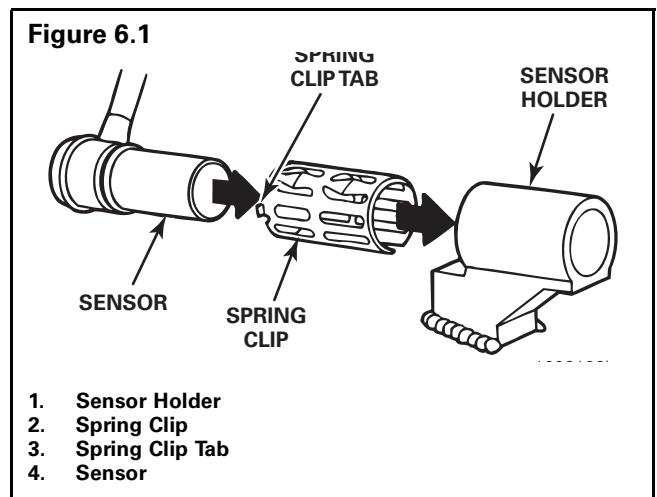

3. Route the sensor cable toward the brake chamber, over the brake spider, and behind the axle. Secure the cable to the axle between the brake spider and the suspension brackets. Continue to route the sensor cable behind the spring seats. Secure the cable to the axle one inch from the molded sensor plug. **Figure 6.2.**

Figure 6.2

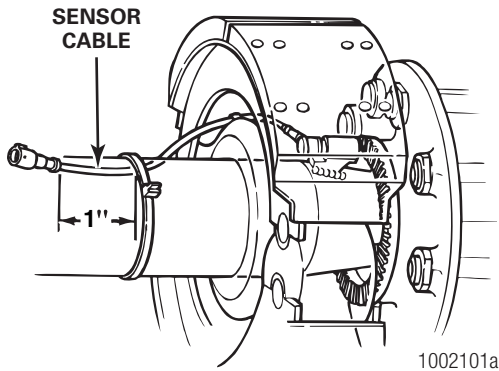

1. Sensor Cable

4. Install the wheel hub carefully, so that the tooth wheel pushes against the sensor as you adjust the wheel bearings. After installation there should be no gap between the sensor and the tooth wheel. During normal operation a gap of 0.040-inch is allowable.
3. **Sensor Output Voltage Test:** Use a volt/ohm meter to check the AC output voltage of the sensors while rotating the wheel at approximately one-half revolution per second. Minimum output must be greater than 0.2 volts AC. If minimum output is less than 0.2 volts AC, push the sensor toward the tooth wheel. Recheck the sensor output.

ABS Relay Valve (Figure 6.3)

Figure 6.3

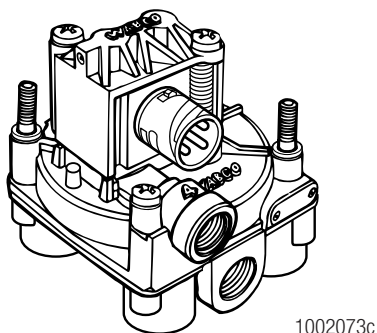

WARNING

Release all pressure from the air system before you disconnect any components. Pressurized air can cause serious personal injury.

How to Remove a Standard ABS Relay Valve

1. Release all pressure from the air system.
3. Disconnect the cable from the valve.
3. Attach labels to identify all of the air lines.
3. Disconnect the air lines from the valve.
3. Remove the mounting fasteners if the valve is not nipple-mounted directly to the air tank.
3. Remove the valve.

How to Install a Standard ABS Relay Valve

CAUTION

You must use Schedule 80 pipe nipple (3/4-inch NPTF) to nipple-mount the ABS relay valve securely to the reinforced air tank to avoid possible serious personal injury and damage to components.

1. Install the valve with two lock nuts and washers as required. Tighten the hex nuts to a torque of 18 lb-ft (24 N•m) or nipple-mount the valve directly to the air tank with Schedule 80 pipe nipple (3/4-inch NPTF). 
3. Connect the air lines to the ports according to the labels installed when the air lines were disconnected.
3. Connect the cable to the valve.
3. Pressurize the brake system. Apply the brakes and verify there are no air leaks.

The ECU/Valve Assembly

⚠ WARNING

Release all pressure from the air system before you disconnect any components. Pressurized air can cause serious personal injury.

How to Remove the ECU/Valve Assembly

1. Release all pressure from the air system.
3. Attach labels to identify all air lines.
3. Disconnect the air lines from the ECU/Valve Assembly.
3. Disconnect the power (or power/diagnostic) cable, additional relay valve cable (if used), and all sensor cables from the ECU/Valve Assembly. **Figure 6.4.**
3. Remove the ECU/Valve Assembly from its mounting location:
 - A. **Bracket-mounted:** Loosen and remove the two mounting bolts and lock nuts that hold the assembly to the cross member. Remove the assembly.
 - B. **Nipple-mounted to Air Tank:** Unscrew the assembly from the air tank.
3. If the assembly being replaced is under warranty, please return it to the trailer OEM for replacement.

How to Install the ECU/Valve Assembly

NOTE: The ECU/Valve Assembly is supplied with black protective caps on each sensor connector.

NOTE: When a sensor cable is not plugged into a sensor connector, the black cap must remain on the connector to protect it from dirt and contamination. **Figure 6.4.**

Figure 6.4

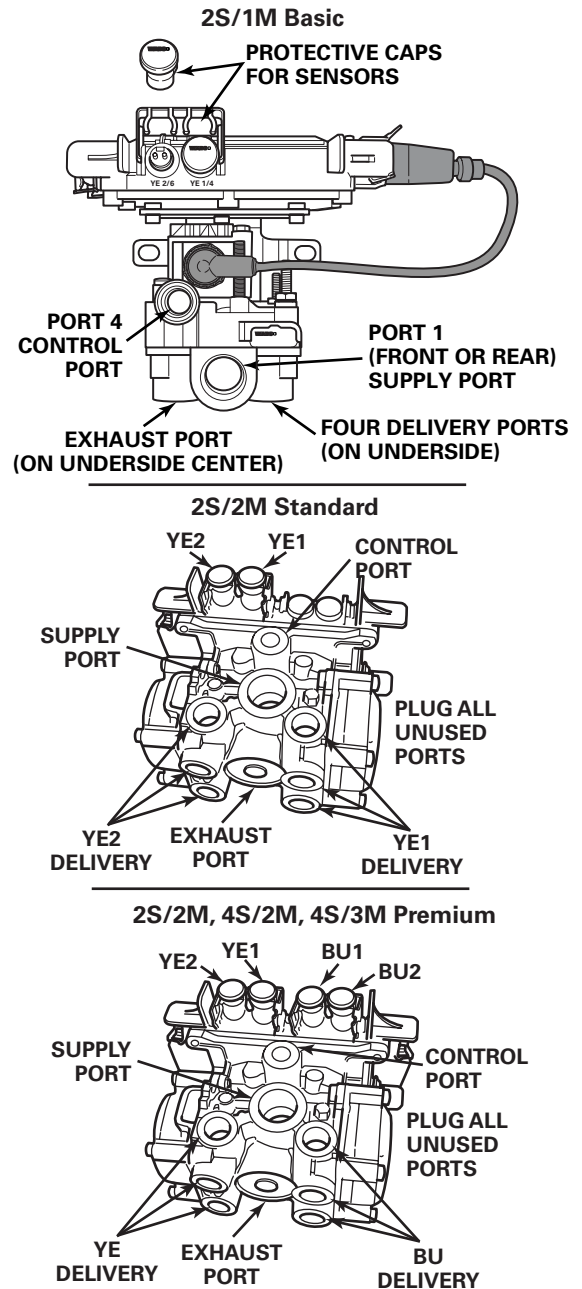

Section 6 Component Replacement

MERITOR WABCO

CAUTION

You must use a Schedule 80 pipe nipple (3/4-inch NPTF) to nipple mount the ECU/Valve Assembly securely to the air tank to avoid possible serious personal injury and damage to components.

Tank-Mounted

WARNING

You must use a Schedule 80 hex nipple (3/4-inch NPTF) to mount the ECU/single modulator valve assembly securely to the air tank to avoid possible serious personal injury and damage to the component.

1. Use a 3/4-inch Schedule 80 hex nipple to attach ECU/single modulator valve assembly to a reinforced air tank. Do not overtighten.

NOTE: Meritor WABCO does not recommend use of a vise when installing the hex nipple. Use of a vise may cause overclamping. Overclamping may damage the internal components of the ECU/single modulator valve assembly.

3. Use a 3/4-inch pipe plug to plug unused supply port (Port 1). Apply SAE-standard, DOT-approved Teflon tape or paste-type thread sealant to all pipe threads beyond the first two threads. Pipes with pre-applied thread sealant may also be used.
3. Rotate and tighten the ECU/single modulator valve assembly until the exhaust port faces down and the connection is secure. Use a torque wrench or ratchet with extension at the 3/4-inch pipe plug installed on the front supply port (Port 1). **Figure 6.5.**

Figure 6.5

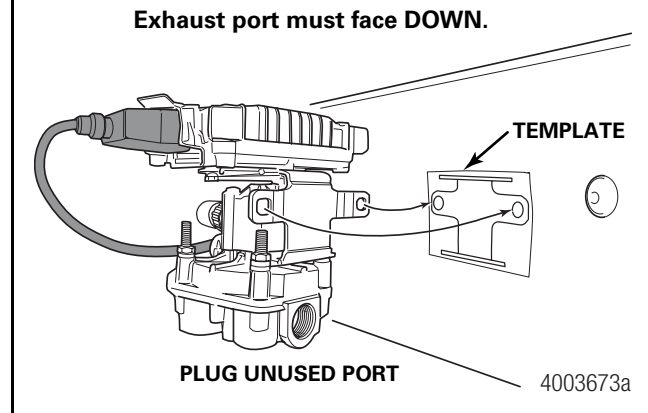

Bracket-Mounted to Cross Member of Vehicle (2S/1M Basic)

1. Install a 3/4-inch NPTF fitting in supply port (Port 1). Use a 3/4-inch pipe plug to plug unused supply port (Port 1).
 - Use a 3/4-inch pipe plug to plug unused supply port (Port 1). Apply SAE-standard, DOT-approved Teflon tape or paste-type thread sealant to all pipe threads beyond the first two threads. Pipes with pre-applied thread sealant may also be used.
3. Attach mounting bracket to vehicle cross member midway between the side rails, close to the brake chambers the valve serves.
3. Use two 3/8-inch Grade 8 bolts with prevailing torque nuts and washers to attach assembly to the vehicle cross member. Tighten bolts to 18 lb-ft (24 N•m). 

Mounted to Cross Member of Vehicle — Standard and Premium Mounting Bracket Not Supplied

NOTE: When mounting the ECU/dual modulator valve assembly to the trailer cross member, refer to SAE specification J447, *Prevention of Corrosion of Motor Vehicle Body and Chassis Components*. Follow all recommendations and procedures. Your supervisor should have a copy of this specification. **Figure 6.6.**

1. Install a 3/4-inch NPTF fitting in supply port. Use a 3/4-inch pipe plug to plug unused supply port (Port 1).
 - Apply SAE-standard, DOT-approved Teflon tape or paste-type thread sealant to all pipe plugs beyond the first two threads. Pipes with pre-applied thread sealant may also be used.
3. Use two 3/8-inch Grade 8 bolts with prevailing torque nuts to attach assembly. Tighten bolts to 18 lb-ft (24 N•m). 
3. Connect the air lines to the ports. Follow the label markers installed when the air lines were disconnected.
3. Connect the sensor cables, external relay valve cable (if used), and power or power/diagnostic cable to the ECU/Valve Assembly. Use the black protective connector caps included with the replacement assembly to cover unused cable connectors.
3. Perform End of Line Check before returning the trailer to service.

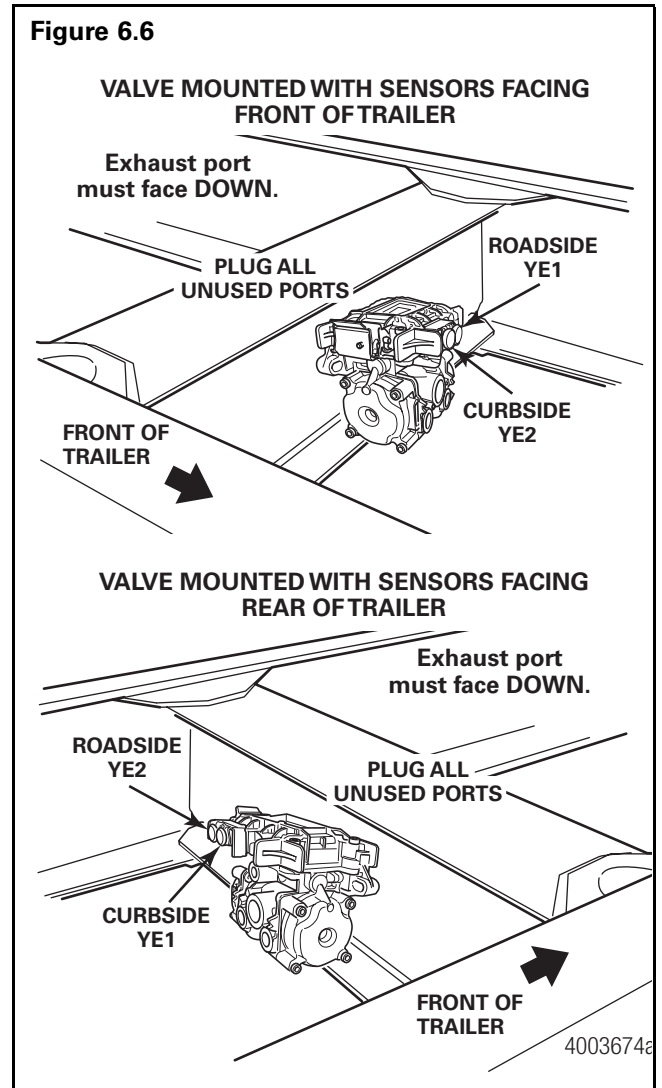

Section 6 Component Replacement

MERITOR WABCO

Replacing the ECU or Modulator Valve

With Enhanced Easy-Stop, the ECU and modulator valve may be replaced individually. To do this, follow the instructions for removing the complete assembly, then remove the valve from the ECU.

NOTES:

For 2S/1M installations where the valve is readily accessible, it may not be necessary to remove the entire assembly to replace the valve.

For 2S/1M bracket-mounted installations, the bracket does not need to be removed to replace the ECU or valve.

2S/1M Basic Only

To separate the ECU from the bracket, loosen and remove the three hex nuts from the underside of the bracket. These three hex nuts hold the assembly together.

To separate the bracket from the valve, remove the three hex nuts. **Figure 6.7.**

To attach the ECU to the bracket, tighten the three hex nuts to 6 lb-ft (8 N•m). 

To attach the valve to the bracket, tighten the three hex nuts to 12 lb-ft (16 N•m). 

All Standard and Premium Installations

Loosen and remove the four hex nuts holding the assembly together. **Figure 6.7.**

To attach the valve to the ECU, tighten the four hex nuts to 5 lb-ft (6 N•m). 

Figure 6.7

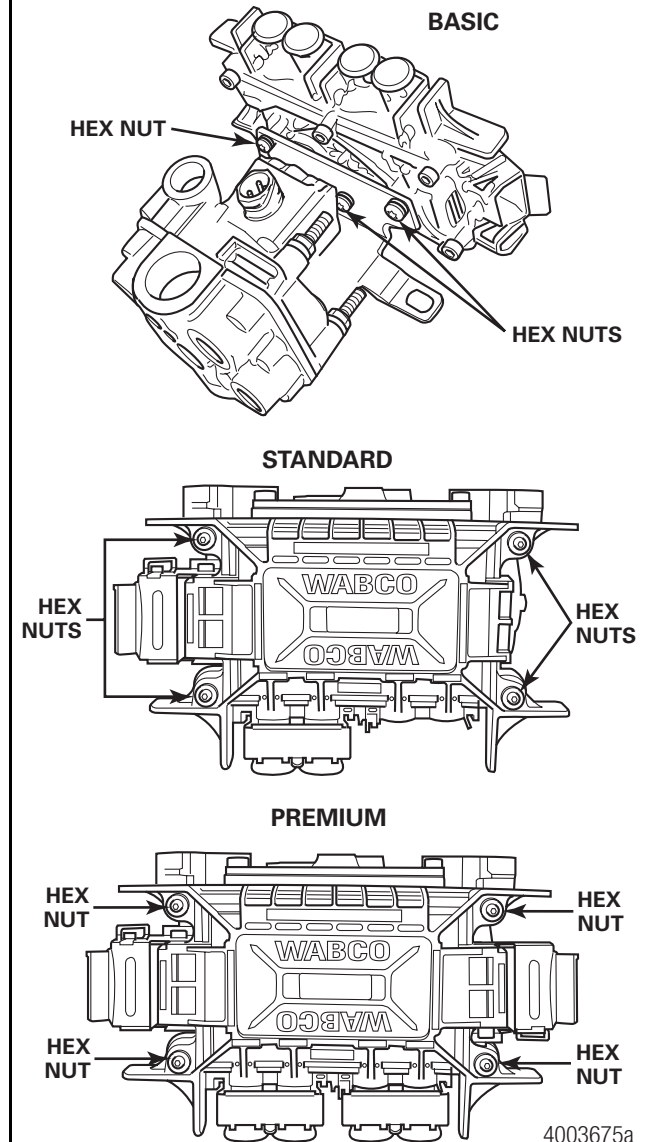

How to Test Wheel Speed Sensors

NOTE: At initial installation, no gap must exist between the sensor and the tooth wheel.

NOTE: After you install a hub, always check that the sensor is adjusted properly.

Operating the trailer can cause a gap to develop between the sensor and the tooth wheel. If the gap exceeds 0.040-inch, the system may not function correctly.

To adjust the sensor, twist and push the sensor through the sensor bracket as far as possible or until the sensor touches the tooth wheel.

Sensor Test Procedure

1. Disconnect power to the ECU/Valve Assembly.
2. Disconnect the sensor electrical connector from the ECU/Valve Assembly.
3. Connect the volt/ohm meter leads to the two wire component terminals inside the disconnected connector.
4. When checking the resistance, the meter must read 900-2000 ohms.
5. Check and replace the sensor and cables as required.
6. Repeat Steps 1-5 for each sensor in the system.

Sensor Output Voltage Test

1. Disconnect power from the ECU/Valve Assembly.
2. Connect the AC volt/ohm meter leads to the sensor terminals inside the connector.
3. Rotate the corresponding wheel at a constant speed of one-half revolution per second.
4. The output voltage must be greater than 0.2 volts AC.
5. When there is no reading:
 - A. Trace the cable to verify that the cable connects to the wheel you turned.
 - B. Check that you turned the correct wheel.
 - C. Check that the system is wired correctly.
 - D. Check that the sensor touches the tooth wheel.

6. If the volt/ohm meter still indicates no reading or a low reading after following the above procedures, check and replace the component and cables as required.
7. Repeat Steps 1-5 for each sensor in the system.

Check ABS Functions

- Meritor WABCO recommends that you test a vehicle's ABS after a new installation and after you diagnose, repair and erase faults in the ABS.
- Perform end of line check using TOOLBOX Software or the Pro-Link 9000.

ABS External Modulator Valve

Measure resistance across each valve solenoid coil terminal and ground on the ABS valve to ensure 4.0 to 8.0 ohms. Valve and cable pinouts are illustrated in **Figure 7.1**.

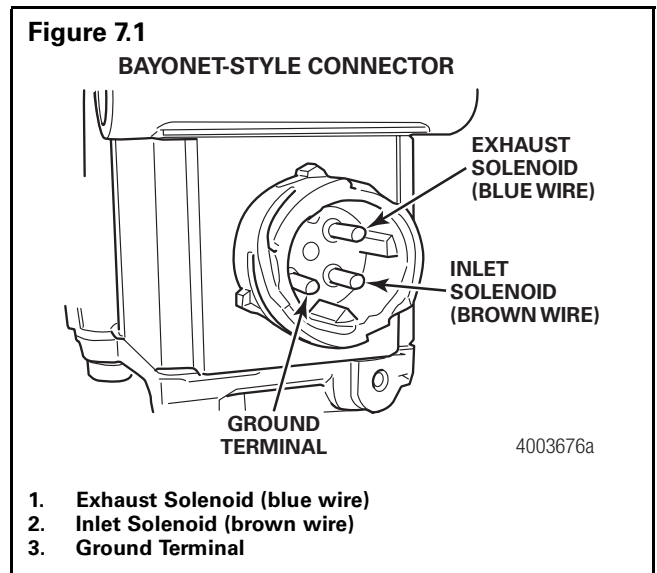

Section 7 Sensor Adjustment & Component Testing

MERITOR WABCO

- To check the cable and the ABS valve as one unit, measure resistance across pins 5 and 6 and 5 and 7 on the ECU connector of the harness. Resistance should be between 4.0 and 8.0 ohms for each measurement. **Figure 7.2.**

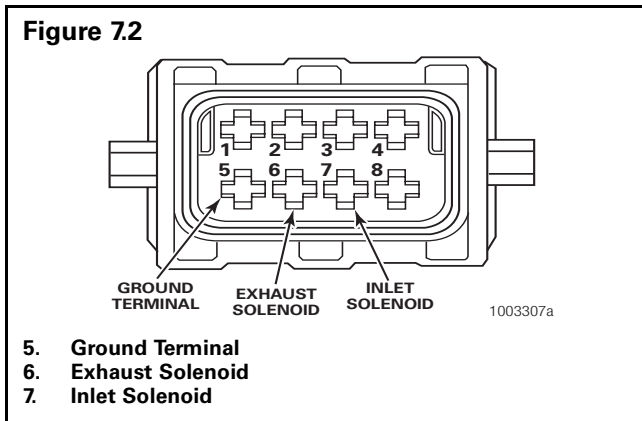

- If the resistance is greater than 8.0 ohms, clean the electrical contacts. Check the resistance again.

End of Line Testing

End of line testing is required on all Enhanced Easy-Stop installations. To run these tests, Meritor WABCO recommends you use TOOLBOX Software.

TOOLBOX Software and general test procedures are included in this manual. If you are using a Pro-Link, refer to the operating manual for test instructions.

End of Line Testing Procedure Using TOOLBOX Software (All Installations)

NOTE: If you are testing an installation that has a power only cable, temporarily install a Meritor WABCO combination power/diagnostics "Y" style cable or use the PLC/J1708 Adapter.

- Connect the diagnostic connector on the cable to the PC serial port/SAE diagnostic interface (J1587/J1708 to RS232 interface).

NOTE: Refer to the Software Owner's Manual, TP-99102, for instructions for running TOOLBOX Software.

- Display the **Trailer ABS Main Screen.**
 - Verify power supply:
 - Apply 12 volts DC to the blue wire (constant). Check the screen for proper voltage (9.5 to 14 volts). Constant power voltage is displayed in the **Primary** field. **Figure 7.3.**
 - Apply 12 volts DC to the red wire (stoplight power). Check the screen for proper voltage (9.5 to 14 volts). Stoplight power voltage is displayed in the **Secondary** field. **Figure 7.3.**
- NOTE:** The internal field is not applicable to this test.
- Check the Faults field on the Main Screen:

NONE = No faults present, proceed with end of line test.

YES = Faults present, double-click on "YES" to bring up the fault information screen.

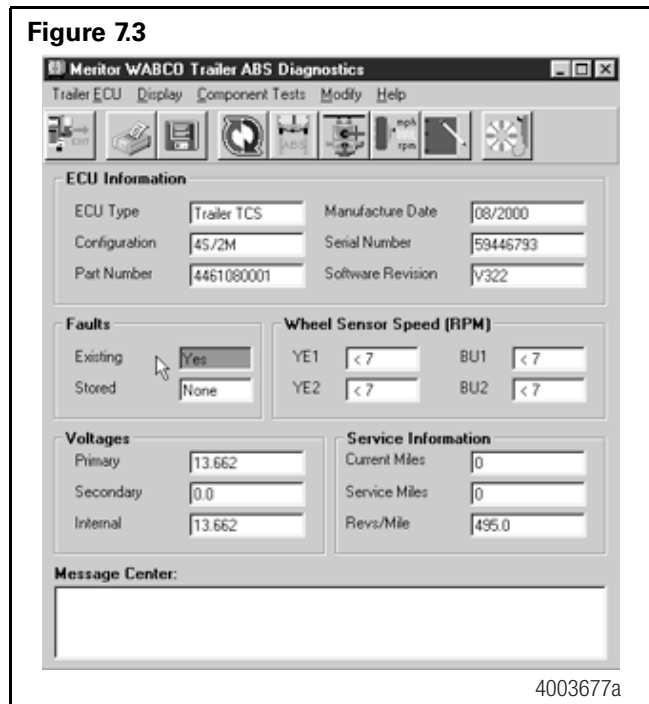

Use the information in the **Repair Instructions** field to make the necessary repairs. **Figure 7.4.**

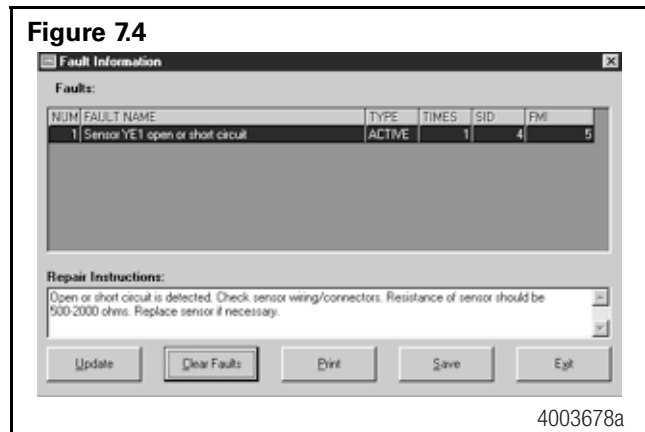

Verify Proper Valve and Lamp Installation (2S/1M Basic)

To verify valve and lamp installations with TOOLBOX Software:

1. At the Trailer **Main Screen** click on **Component Test**, then select **Valves/Lamp** to display the **Valve Activation** Screen. **Figure 7.5.**
2. The Red valve indicator will be selected. Click on the **Activate** button and listen for the valve to click, indicating a good installation. The **Test Status** box at the bottom of the menu will also display the status of this test.
3. Click on the **Test** button to activate the ABS indicator lamp — this is the lamp that is mounted on the side of the trailer. The lamp will flash eight times, indicating lamp installation is OK. The **Test Status** box at the bottom of the menu will also display the status of this test.
4. Click on **Close** to exit.

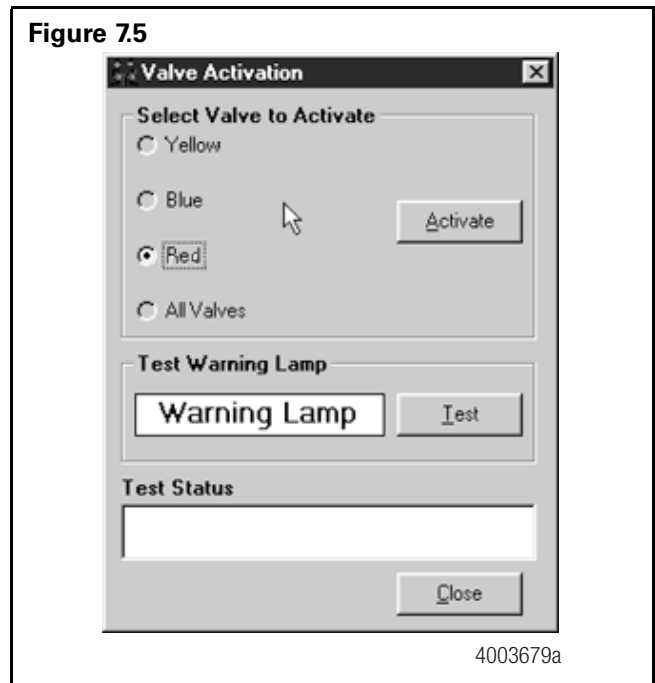

2S/2M, 4S/2M, 4S/3M (Standard and Premium)

To verify valve and lamp installations with TOOLBOX Software:

1. Apply 12 volts DC to the ABS.
2. Apply air to the emergency line to fill the air tanks and release the spring brakes.
3. Apply air to the control line.
4. At the Trailer **Main Screen** click on **Component Test**, then select **Valves/Lamp** to display the **Valve Activation** Screen. The **Yellow** valve indicator will be highlighted. **Figure 7.6.**

NOTE: Selecting “All Valves” will sequence all of the valves beginning with the **Yellow** valve.

5. Click on the Activate button.

Section 7 Sensor Adjustment & Component Testing

MERITOR WABCO

6. Check for proper air line installation. To do this, observe the slack adjusters:
 - If the ECU faces **the front of the trailer**, the slack adjusters will move in and out as the **curbside** portion of the dual modulator valve cycles. If this does not happen, the air lines are not properly connected. Make the necessary repairs.
 - If the ECU faces **the rear of the trailer**, the slack adjusters will move in and out as the **roadside** portion of the dual modulator valve cycles. If this does not happen, the air lines are not properly connected. Make the necessary repairs.

NOTE: The Test Status box at the bottom of the menu will display the status of this test.

7. Repeat this test for the **Blue** valve.
 - A. Repeat Steps 1-3.
 - B. Select the **Blue** valve from the valve activation screen.
 - C. Click on the activate button to verify proper valve installation (**Blue**).
 - D. Check for proper air line installation. To do this, observe the slack adjusters.
 - If the ECU faces **the front of the trailer**, the slack adjusters will move in and out as the **roadside** portion of the dual modulator valve cycles. If this does not happen, the air lines are not properly connected. Make the necessary repairs.
 - If the ECU faces **the rear of the trailer**, the slack adjusters will move in and out as the **curbside** portion of the dual modulator valve cycles. If this does not happen, the air lines are not properly connected. Make the necessary repairs.
8. **For 4S/3M installations:** Repeat this test for the red valve.

Red: The external relay valve designated RED (RD) is an axle control valve. It controls brake chambers on one or two axles. It is important that delivery lines from port #2 are plumbed as shown on the installation drawings. The 4S/3M system is designed to be used with a variety of trailer configurations. Call ArvinMeritor's Customer Service Center at 800-535-5560 for additional information.

9. Click on the **Test** button to activate the ABS indicator lamp — this is the lamp that is mounted on the side of the trailer. The lamp will flash eight times, indicating lamp installation is OK. The **Test Status** box at the bottom of the menu will display the status of this test. **Figure 7.6**.
10. Click on **Close** to exit.

Figure 7.6

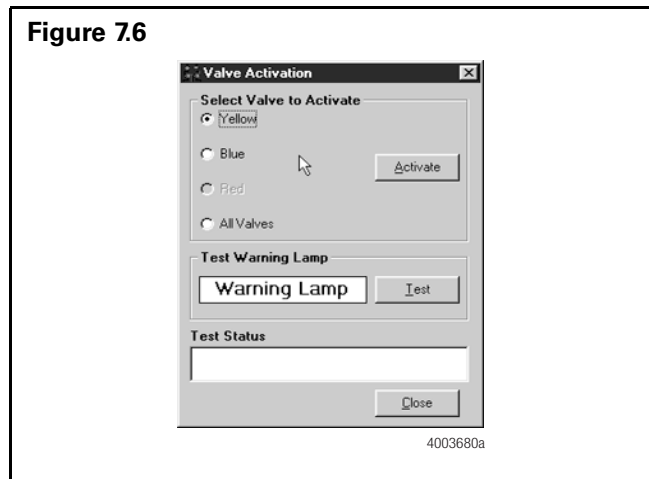

Sensor Installation Test (All Installations)

To test the sensor installation:

1. Raise both sensed wheel ends off of the ground.
2. Apply air to the emergency line to fill the air tanks and release the spring brakes so that the wheels can be rotated.
3. Apply 12 volts DC to the ABS.
4. At the **Trailer Main Menu**, click on **Component Test**, then select **Sensor Test** to display the **Sensor Test** screen.
5. Click on the **Start** button to start the test.
6. Rotate the sensed wheel ends at a rate of 1/2 revolution per second. This rate equals a wheel speed of approximately 4 mph (7 kph).

7. Check the screen for sensor output. **Figure 7.7.**
 - Make sure there is sensor output. If sensor output is displayed, sensor test is complete.
 - If there is no sensor output, verify that a tone ring has been installed and that the sensor is pushed all the way in against the tone ring. Make the necessary repairs and repeat the sensor test. If the problem persists, contact Meritor WABCO.
8. Check **Order** fields to verify sensors were installed in the right location based on orientation of the valves. **Figure 7.7.**

NOTE: Refer to page 45 of this manual for sensor locations.

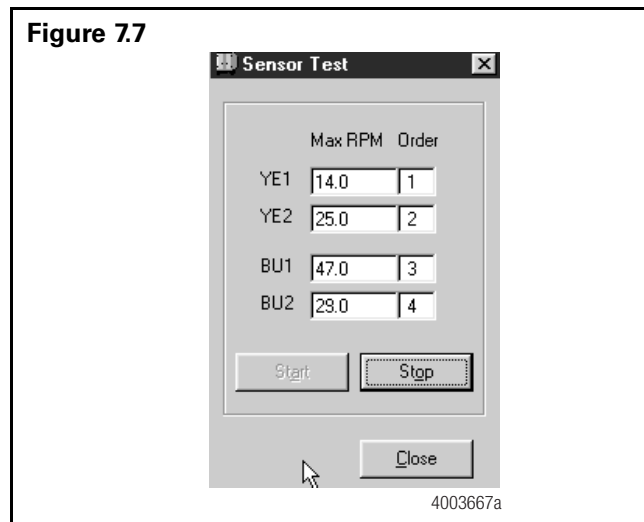

End of Line Testing without TOOLBOX Software

2S/1M Basic

1. Apply 12 volts DC power to the ABS.
2. The ECU/single modulator valve assembly should click two times.
3. If the indicator lamp **comes on** for three seconds and **goes out**:

This indicates a proper installation. The end of line test is complete.

If the ABS indicator lamp **comes on** and **stays on**, check the sensor installation:

- A. Remove the power from the ABS and raise the sensed wheels so they may be rotated.
- B. Repeat Step 1 and Step 2.
- C. Rotate each sensed wheel — one at a time — at a rate **less than 25 rpm**.

The ABS indicator lamp should now go out and stay out indicating a proper installation. The end of line test is complete.

4. If the ABS lamp does not go out, there is a sensor gap problem or hardware fault. Adjust the sensor and, if necessary, perform a fault code check.

Section 7

Sensor Adjustment & Component Testing

MERITOR WABCO

Inspect the Sensor and Air Line Installation (2S/2M Standard)

Sensor Installation

1. Look at the YE2 and YE1 sensor connectors on the ECU/dual modulator valve assembly. Make sure the connectors are routed to the proper wheel end location, as follows:
 - If the ECU/dual modulator valve assembly is mounted with sensors facing the front of the trailer:
 - Sensor YE2 must be routed to the curbside wheel end location
 - Sensor YE1 must be routed to the roadside wheel end location
 - If the ECU/dual modulator valve assembly is mounted with sensors facing the rear of the trailer:
 - Sensor YE2 must be routed to the roadside wheel end location
 - Sensor YE1 must be routed to the curbside wheel end location
2. If sensors are not properly installed, make the necessary repairs.

Air Line Installation

1. Make sure all unused air ports are plugged and that the exhaust port is facing DOWN.
2. Look at the air line installation to make sure all air lines are properly installed.
 - If the ECU/dual modulator valve assembly is mounted with the sensors facing the **front** of the trailer, the air lines for the three delivery ports located under the YE2 sensor connector must be routed to **curbside**; the air lines for the three delivery ports on the opposite side of the valve must be routed to roadside.

Figure 7.8.

 - If the ECU/dual modulator valve assembly is mounted with the sensors facing the **rear** of the trailer, the air lines for the three delivery ports located under the YE2 sensor connector must be routed to **roadside**; the air lines for the three delivery ports on the opposite side of the valve must be routed to curbside.

Figure 7.9.

3. If air lines are not properly routed, make the necessary repairs.

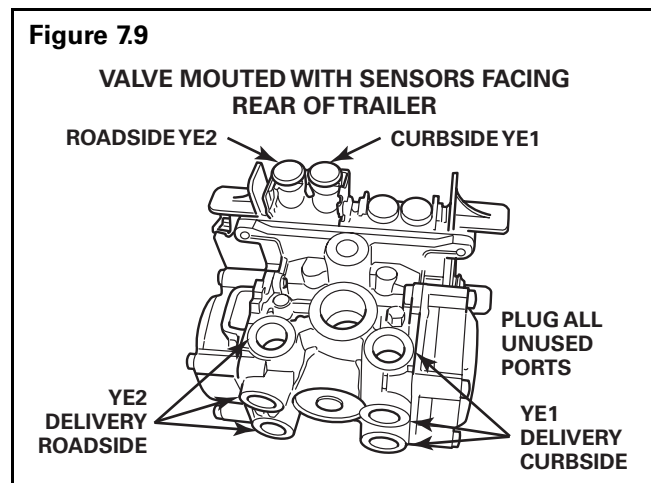
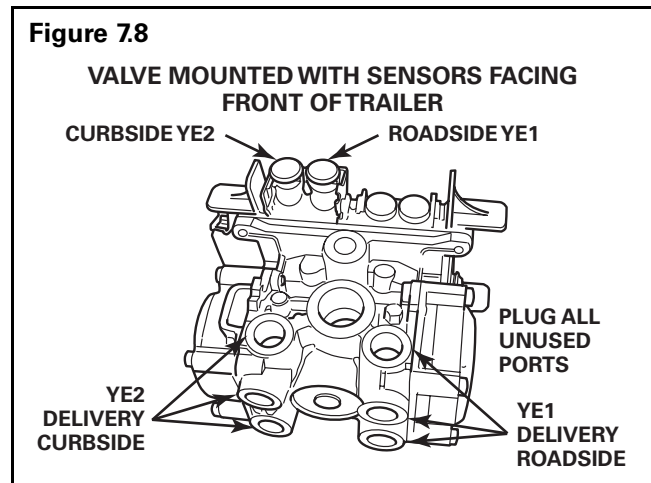

Inspect the Sensor and Air Line Installation (2S/2M, 4S/2M and 4S/3M Premium)

Sensor Installation

1. Look at the sensor connectors on the ECU/dual modulator valve assembly. Make sure the connectors are routed to the proper wheel end location, as follows:

ECU/Dual Modulator Valve Assembly Mounted with Sensors Facing Front of Trailer

- 2S/2M
 - Connect curbside sensor at YE1.
 - Connect roadside sensor at BU1.
- * • 4S/2M
 - Connect curbside front sensor at YE1.
 - Connect curbside rear sensor at YE2.
 - Connect roadside front sensor at BU1.
 - Connect roadside rear sensor at BU2.
- * • 4S/3M — Sensor locations vary by type of installation. Refer to diagrams for specific sensor locations.
 - Connect curbside sensor at YE1.
 - Connect curbside sensor at YE2.
 - Connect roadside sensor at BU1.
 - Connect roadside sensor at BU2.

ECU/Dual Modulator Valve Assembly Mounted with Sensors Facing Rear of Trailer

- 2S/2M
 - Connect curbside sensor at BU1.
 - Connect roadside sensor at YE1.
 - * • 4S/2M
 - Connect curbside front sensor at BU1.
 - Connect curbside rear sensor at BU2.
 - Connect roadside front sensor at YE1.
 - Connect roadside rear sensor at YE2.
 - * • 4S/3M — Sensor locations vary by type of installation. Refer to diagrams for specific sensor locations.
 - Connect curbside sensor at BU1.
 - Connect curbside sensor at BU2.
 - Connect roadside sensor at YE1.
 - Connect roadside sensor at YE2.
- * **If the lift axle is sensed in 4S/2M and 4S/3M installations:** Sensors YE2 and BU2 must always be used on the lift axle to avoid an unwanted ABS indicator lamp illumination.
2. If sensors are not properly installed, make the necessary repairs.

Air Line Installation

1. Make sure all unused air ports are plugged and that the exhaust port is facing DOWN.
2. Look at the air line installation to make sure all air lines are properly installed.
 - If the ECU/dual modulator valve assembly is mounted with the sensors facing the **front** of the trailer, the air lines for the three delivery ports located under the YE sensor connectors must be routed to **curbside**; the air lines for the three delivery ports on the opposite side of the valve must be routed to roadside. Refer to **Figure 7.10**.
 - If the ECU/dual modulator valve assembly is mounted with the sensors facing the **rear** of the trailer, the air lines for the three delivery ports located under the YE sensor connectors must be routed to **roadside**; the air lines for the three delivery ports on the opposite side of the valve must be routed to curbside. Refer to **Figure 7.11**.

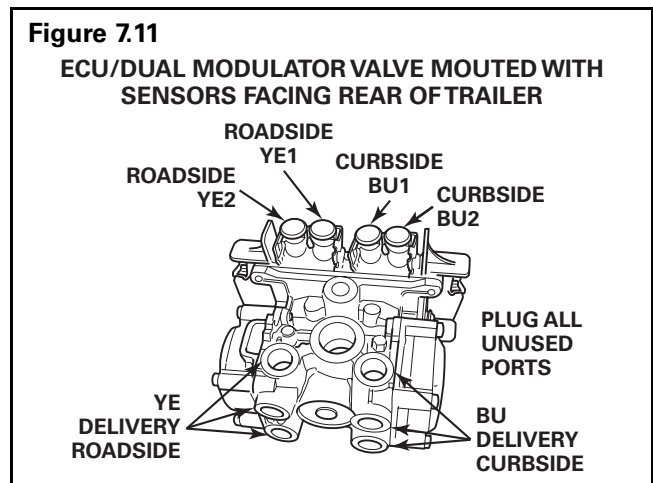
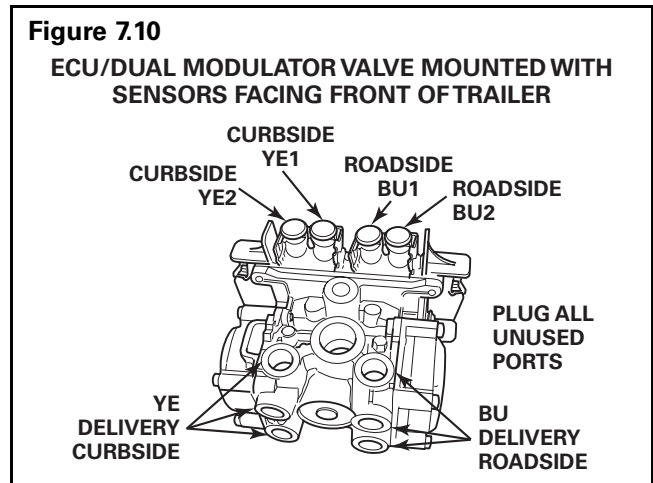

Section 7 Sensor Adjustment & Component Testing

MERITOR WABCO

3. **For 4S/3M installations:** Repeat this test for the red valve.

Red: The external relay valve designated RED (RD) is an axle control valve. It controls brake chambers on one or two axles. It is important that delivery lines from port #2 are plumbed as shown on the installation drawings. (Refer to **Figures 4.8, 4.9 and 4.10.**) The 4S/3M system is designed to be used with a variety of trailer configurations. Call ArvinMeritor's Customer Service Center at 800-535-5560 for additional information.

4. If air lines are not properly routed, make the necessary repairs.

Perform End of Line Test (Standard and Premium Installations)

1. Apply 12 volts DC power to the ABS.
2. The ECU/dual modulator valve assembly should click four times (six times for a 4S/3M).
3. If the indicator lamp **comes on** for three seconds then **goes out**, this indicates a proper installation. The end of line test is complete.

If the ABS indicator lamp **comes on** and **stays on**, check the sensor installation:

- A. Remove the power from the ABS and raise the sensed wheels so they may be rotated.
- B. Apply emergency air to fill the air tanks and release the spring brakes so that the wheels may be rotated.
- C. Repeat Step 1 and Step 2.
- D. Rotate each sensed wheel — one at a time — at a rate of **less than 25 rpm**.

The ABS indicator lamp should now go out and stay out indicating a proper installation. The end of line test is complete.

4. If the ABS lamp does not go out, there is a sensor gap problem or hardware fault. Adjust the sensor and, if necessary, perform a fault code check.

Sensor Gap Adjustment (All Installations)

Push sensor into its holder until it contacts the tooth wheel. At installation, there must be no gap between the sensor and the tooth wheel.

Measure the AC voltage output. Value should be 0.2 volt AC when wheel is rotated at a rate of 1/2 revolution per second.

Fault Code Check (All Installations)

Use constant power activation to perform the fault code check, as follows:

1. Apply constant power to the ECU/dual modulator valve assembly **for more than one, but less than five seconds**.
2. Remove power.
3. Reapply power.
4. Check the trailer ABS indicator lamp on the side of the trailer. The fault code will be displayed three times.
5. Find the fault on the table and make the necessary repairs.
6. After making the necessary corrections, repeat the end of line test.

BLINK CODES		
Blink Code	Problem Area	Action
3	Sensor BU1	Determine sensor location. Check sensor installation. Make necessary repairs.
4	Sensor YE1	Determine sensor location. Check sensor installation. Make necessary repairs.
5	Sensor BU2	Determine sensor location. Check sensor installation. Make necessary repairs.
6	Sensor YE2	Determine sensor location. Check sensor installation. Make necessary repairs.
7	External ABS modulator valve	Verify proper electrical installation. Check power supply. Make necessary corrections.
9	Internal modulator failure, inlet valve #2	Verify proper installation. If code continues, contact Meritor WABCO for assistance.
10	Internal modulator failure, inlet valve #1	Verify proper installation. If code continues, contact Meritor WABCO for assistance.
11	Internal modulator failure, outlet valve	Verify proper installation. If code continues, contact Meritor WABCO for assistance.
14	Power Supply	Verify proper electrical installation. Check power supply. Make necessary corrections.
15	ECU Failure	Verify proper installation. If code continues, contact Meritor WABCO for assistance.
16	SAE J1708 Failure	Internal failure, contact Meritor WABCO.
17	SAE J2497 (PLC) Failure	Internal failure, contact Meritor WABCO.
18	Generic I/O Failure	Verify proper electrical installation. Check power supply. Make necessary corrections.

Trailer Identification

An Easy-Stop Trailer ABS warning label is generally affixed to the trailer near the ABS trailer indicator lamp.

If this label is not on the trailer, let your supervisor know. Labels are available from Meritor WABCO. Ask for Part Number TP-95172.

For additional assistance, contact ArvinMeritor’s Customer Service Center at 800-535-5560.

Before calling the ArvinMeritor Customer Service Center, be prepared to provide the following information about the trailer you are working on:

1. Trailer make and model year.
2. What is the symptom/complaint? What is the component doing or not doing?
3. What is the ABS blink code or MPSI Pro-Link 9000 reading?
4. Have any resistance and/or voltage measurements been taken?
5. What is the result of visual inspection of connectors, harness and components?
6. When does the symptom occur (vehicle moving, compressor unloading, etc.)?
7. Does the trailer have any unusual characteristics (for example, mismatched tires or larger than normal air consumption)?
8. Were maintenance manuals available? If so, which ones were used?
9. What is the part number of the ECU/Valve Assembly? What is the system configuration?

By having the above information ready when you call, your customer service technician will be better equipped to assist you. Figure 7.12.

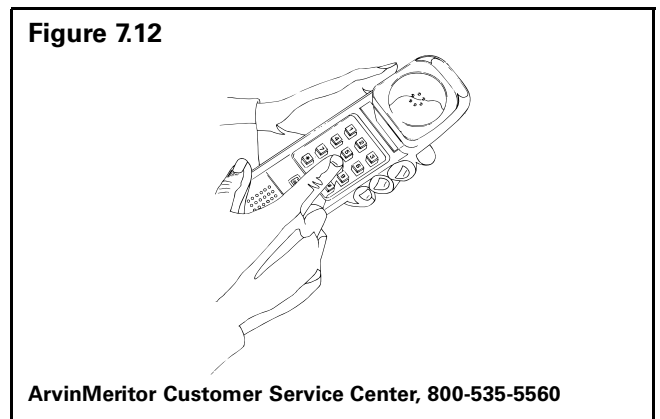
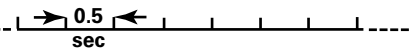
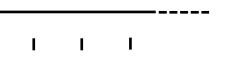



Table E: Dash-Mounted Trailer ABS Indicator Lamp Operation (Information for Service Technicians)

Signal from trailer to tractor ECU	Status of Trailer ABS Lamp on vehicle dash	Explanation	Action
Single or Multiple Trailers message No ON or OFF messages lamp on lamp off 	Trailer ABS lamp does not come on within three seconds of ignition.	Not using the PLC system (no trailer connected) or trailer not equipped with PLC or fault in PLC system.	Use lamp on side of trailer to identify fault. Make necessary repairs.
Single Trailer message OFF OFF OFF ON ON ON ON ON lamp on 	Trailer ABS lamp comes on.	Trailer ABS fault(s) occurred during operation and still exists.	
Multiple Trailers/Dollies message OFF OFF OFF OFF OFF OFF OFF OFF OFF OFF OFF ON ON ON ON lamp on 			
Single Trailer message ON ON OFF OFF OFF OFF OFF OFF lamp on	Trailer ABS lamp comes on but goes out after 2.5 seconds after fault is detected.	Trailer ABS fault occurred during operation and the fault was corrected.	None
Multiple Trailers/Dollies message OFF OFF OFF OFF OFF OFF OFF OFF ON ON OFF OFF OFF OFF OFF OFF lamp on			
Single Trailer message ON ON ON No ON or OFF messages lamp on	ABS lamp is off, comes on, then goes off, 10 seconds after loss of messages.	ABS fault existed, then signal was lost because trailer disconnected or PLC fault.	Use lamp on side of trailer to identify fault. Make necessary repairs.
Multiple Trailers/Dollies message OFF OFF OFF OFF OFF OFF OFF OFF ON ON lamp on			
Single Trailer to Multiples message ON ON ON OFF OFF OFF ON ON ON ON ON ON lamp on	ABS lamp is on and stays on when a new trailer with no new fault is added.	There was a fault in existence before the new trailer was added AND the ignition was not turned off before the trailer was added.	
Single Trailer to Multiples message ON ON ON ON ON ON ON ON ON ON ON ON ON ON lamp on	ABS lamp is on and stays on when a new trailer with a new fault is added.	ABS fault was in existence before the new trailer was added AND the ignition was not turned off before the trailer was added AND the new trailer has an ABS fault.	

ON = Turn ON message to "trailer ABS" lamp
 OFF = Turn OFF message to "trailer ABS" lamp

Removing a trailer with a fault will cause ABS lamp to turn off. Remember to have trailer with fault repaired as soon as possible before returning to service.

MERITOR WABCO

Meritor WABCO Vehicle Control Systems

2135 West Maple Road
Troy, MI 48084-7121 USA
800-535-5560
meritorwabco.com

Information contained in this publication was in effect at the time the publication was approved for printing and is subject to change without notice or liability. Meritor WABCO reserves the right to revise the information presented or to discontinue the production of parts described at any time.

Copyright 2010
ArvinMeritor, Inc.
All Rights Reserved

Printed in USA

Maintenance Manual MM-0180
Revised 02-10
16579/22882