

Meritor Inc. Trailer Axle Service Manual TP Series

Issued: 01/2012



All rights reserved.

No part of this publication may be reproduced in any form or by any means or granted to any third parties without the written permission of MERITOR Inc.

MERITOR Inc. reserves the right to publish revisions at any time for technical or commercial purposes. Therefore all material contained in this manual is based on the latest information available at time of publication approval. Always check at www.meritorhvs.com for the latest edition.

© 2012 Meritor Inc.
Document No. MM-1188
Edition: - 01/2012

pg. 4 Section 1 - General Information

- pg. 5 Service notes
- pg. 5 Safety instructions
- pg. 6 Warranty

pg. 8 Section 2 - Introduction

- pg. 9 Introduction
- pg. 9 Limitations of use
- pg. 10 Exploded view - Hub assembly
- pg. 11 Exploded view - Axle
- pg. 12 Section view - Axle & Hub
- pg. 13 Axle identification plate
- pg. 13 Identifying the axle type

pg. 15 Section 3 - Inspection & Maintenance Procedures

- pg. 16 Disc brake axles
- pg. 16 Rotor inspection
- pg. 17 Rotor run out
- pg. 18 Rotor wear parameters

pg. 21 Section 4 - Hub Service & Replacement

- pg. 22 Hub removal
- pg. 25 Hub refitment

pg. 31 Section 5 - Rotor Replacement

- pg. 32 Rotor removal
- pg. 32 Rotor fitment

pg. 33 Section 6 - ABS Component Replacement

- pg. 34 ABS Pole Wheel replacement
- pg. 35 ABS Sensor replacement
- pg. 35 Checking sensor output

pg. 36 Section 7 - Hub Odometer Replacement

- pg. 37 Hub odometer fitment

pg. 38 Section 8 - Wheel Bolt Replacement

- pg. 39 Removal & Fitting wheel bolts

pg. 40 Section 9 - Maintenance schedules, Torque Values, Lubricants & Grease volumes

- pg. 41 Maintenance schedules
- pg. 42 Torque Values
- pg. 42 Recommended Lubricants
- pg. 42 Grease Fill Volumes

pg. 44 Section 10 - Service Tools

- pg. 45 MST 3103 - Bearing Driver
- pg. 45 MST 3106 - Oil Seal Driver
- pg. 45 MST 3211 - Wheel Bolt Removal Tool
- pg. 45 Oil Seal Driver (Stemco)

General Information

1

pg. 5 Service notes
pg. 5 Safety instructions
pg. 6 Warranty

1 General Information

Service Notes

This manual describes the correct lubrication, service and installation procedures for Meritor Inc.'s TP series axles. Information contained in this publication was in effect at the time the publication was approved for printing and is subject to change without notice or liability.

The designated trademarks are registered marks of their respective owners and Meritor Inc. and its affiliates are not commercially connected, affiliated, or associated with any of the owners of such marks. The Meritor Inc. products presented herein are not endorsed or authorized by any of the trademark owners.

You must follow company procedures and understand all procedures and instructions before you begin to service or repair a unit. Some procedures require the use of special tools and lubricants for safe and correct service. Failure to use special tools when required can cause serious personal injury to service personnel, as well as damage to equipment and components.

Meritor Inc. uses the following notations to warn the user of possible safety issues and to provide information that will prevent damage to equipment and components.



WARNING

A Warning indicates you must follow a procedure exactly. Otherwise serious Personal injury can occur.

NOTE:

A NOTE indicates an operation, procedure or instruction that is important for correct service. A NOTE can also supply information that can help to make service quicker and easier.



CAUTION

A caution indicates that you must follow a procedure exactly. Otherwise, damage to equipment or components can occur. Serious personal injury can also result, in addition to damaged or malfunctioning equipment or components.



This symbol indicates that you must tighten fasteners to a specific torque value.

Safety Instructions

- Observe the manufacturer's safety instructions for jacking up and securing the vehicle
- Only use original Meritor Inc. parts
- Use only the tools recommended.
- Observe the following service instructions and notes
- When working on the brake assembly you must ensure that it cannot be activated inadvertently.
- Always ensure appropriate safety glasses and gloves are worn when carrying out the procedures detailed in this publication.
- Never use compressed air to remove brake dust or for the purpose of drying. Any type of dust can be injurious to health if inhaled. Use Meritor Inc. brake cleaner for cleaning the brake assembly.
- When removing or fitting a complete brake assembly, you should remember it has a dead weight of up to 120lbs (55kg). Use a lifting system, taking care not to damage the brake assembly.



CAUTION: Ensure any grease removed from the assembly/components, or contaminated cloth, is disposed of in accordance with local environmental regulations.



CAUTION: You must always renew the brake pads on both wheels of an axle. Only use brake pads that have been approved by the vehicle manufacturer.



CAUTION: Ensure any discarded friction product, or cloth contaminated with brake dust, is disposed of in accordance with local environmental regulations.



CAUTION: You must always renew the rotor on both wheels of an axle. Only use rotors that have been approved by the vehicle manufacturer.

Access Information on Meritor Inc.'s Web Site

Additional maintenance and service information for Meritor Inc.'s commercial vehicle systems component lineup is also available at www.meritorhvs.com

To access information go to Products & Services Icon; from drop down menu click on Literature on Demand. The screen will display an index of publications by type.

Meritor Inc. Axle Warranty

For full warranty terms and conditions see 'Meritor Inc. Warranty Terms and Conditions

Unless otherwise stated, Aftermarket components are warranted for 1 year, parts only, mechanical failure only.

Warranty Procedure

Should any Meritor Inc. equipment fitted to your trailer become unserviceable within the warranty period, contact the trailer manufacturer or Meritor Inc. Service Department who will advise on the appropriate action.

A comprehensive network of original parts distributors and service stations operate throughout Europe; this is supported internationally with agents strategically placed around the world.

MERITOR Inc. reserves the right to make changes in specifications shown herein or add improvements at any time without notice or obligation.

PARTS SHOWN ARE MADE FROM DRAWINGS IN WHICH COPYRIGHT SUBSISTS. THE MAKING OF COPIES OF ANY OF THESE PARTS IS PROHIBITED.

ROR, MERITOR, MERITOR Inc. AND INDAIR ARE ALL REGISTERED TRADE MARKS IN THE UK AND ELSEWHERE



The high quality assurance management systems applied by Meritor Inc. are endorsed with the awarding of ISO 9001, Lloyd's Register Quality Assurance.

© 2012 Meritor Inc. Ltd.

Introduction

2

- pg. 9 Introduction
- pg. 9 Limitations of use
- pg. 10 Exploded view - Hub
- pg. 11 Exploded view - Axle
- pg. 12 Section view - Axle & Hub
- pg. 13 Axle identification plate
- pg. 13 Identifying the axle type

2 Introduction

The maintenance procedures detailed in this manual apply to the Meritor Inc. TP series trailer axles.

The TP series axles are designed for use with Meritor Inc. CS9i suspension and ELSA EX225L air disc brakes.

For information regarding the CS9i suspension assembly, refer to the Meritor Inc. CS9i service manual MM 0556.

For information regarding the ELSA EX225L air disc brake assembly, refer to the Meritor Inc. EX225L service manual MM 0350.

Limitations of Use

In cases where suspensions of non-Meritor manufacture are used, the trailer builder or suspension manufacturer must satisfy themselves as to the suitability and compatibility of the axle and suspension, particularly from a durability standpoint. Meritor will be pleased to assist in assessing such compatibility, but cannot warrant the fitment of its axles to suspensions of unknown characteristics.

2 Introduction

Exploded View

TP Hub Assembly

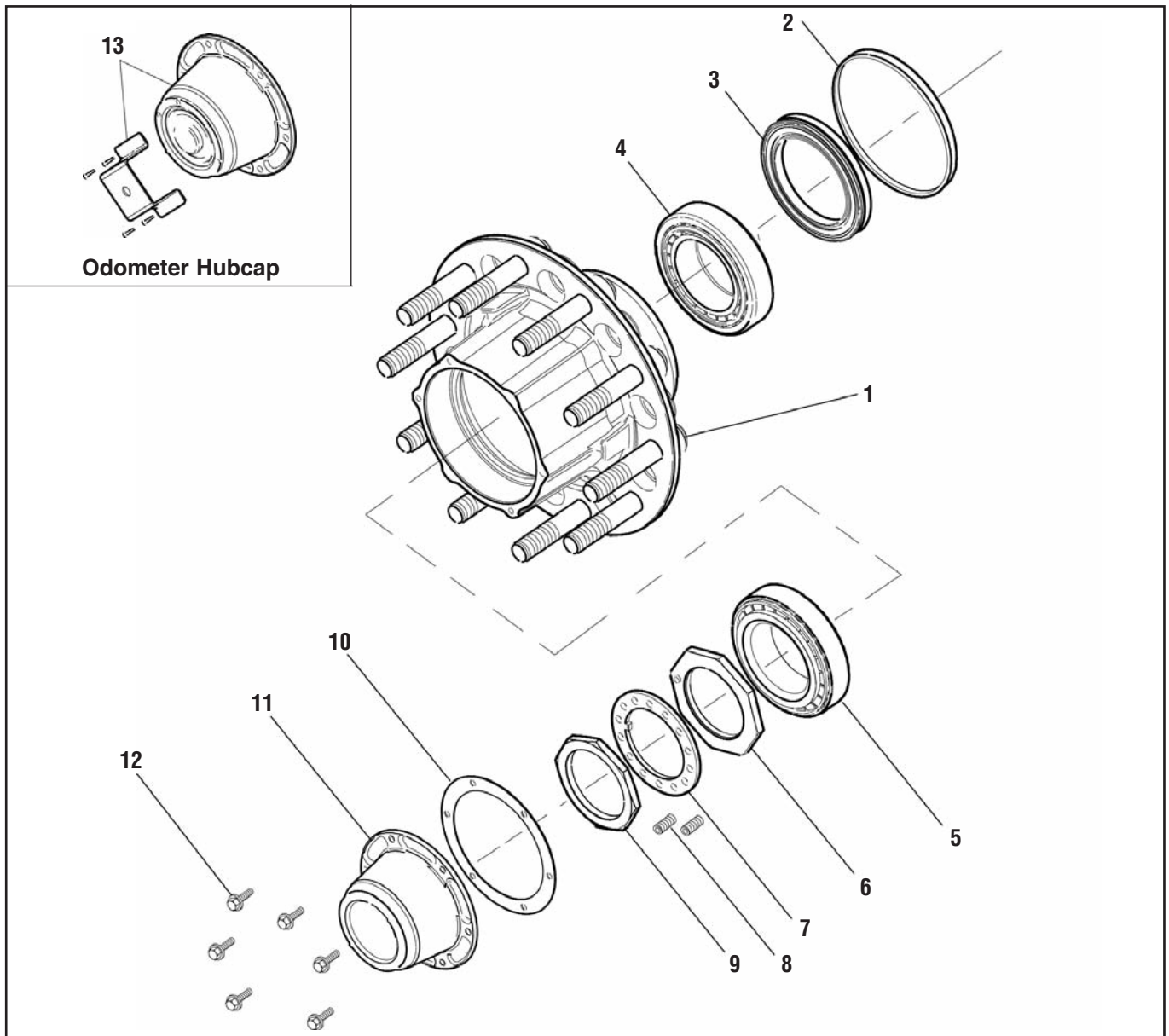

Fig 2.1

Item	Description	QTY (per axle)	Item	Description	QTY (per axle)
1	Hub	2	11	Hub Cap	2
2	ABS Pole Wheel	2	12	Retaining Screw	12
3	Seal	2	13	Odometer Hub Cap	2
4	Inner Bearing	2			
5	Outer Bearing	2			
6	Hub Adjusting Nut	2			
7	Hub Locking Plate	2			
8	Socket Head Screw	4			
9	Hub Locknut	2			
10	Gasket	2			

2 Introduction

Exploded View

TP Axle Components

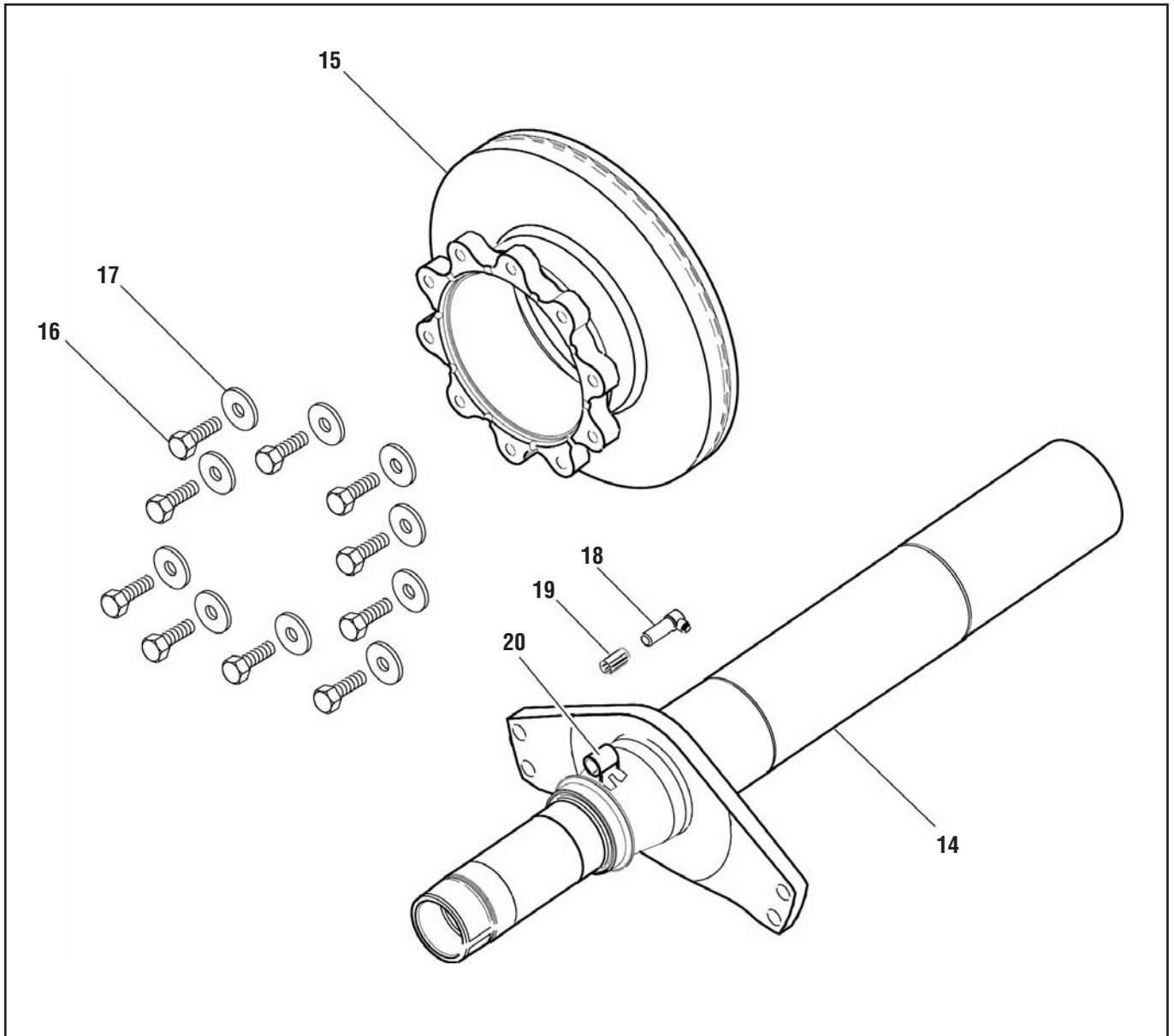

Fig 2.3

Item	Description	QTY (per axle)
14	Axle Beam	1
15	Rotor	2
16	Rotor Bolt	20
17	Hardened Washer	20
18	Sensor	2
19	Sensor Bush	2
20	Sensor Mounting Block (welded)	2

2 Introduction

Section View

TP Axle & Hub Components

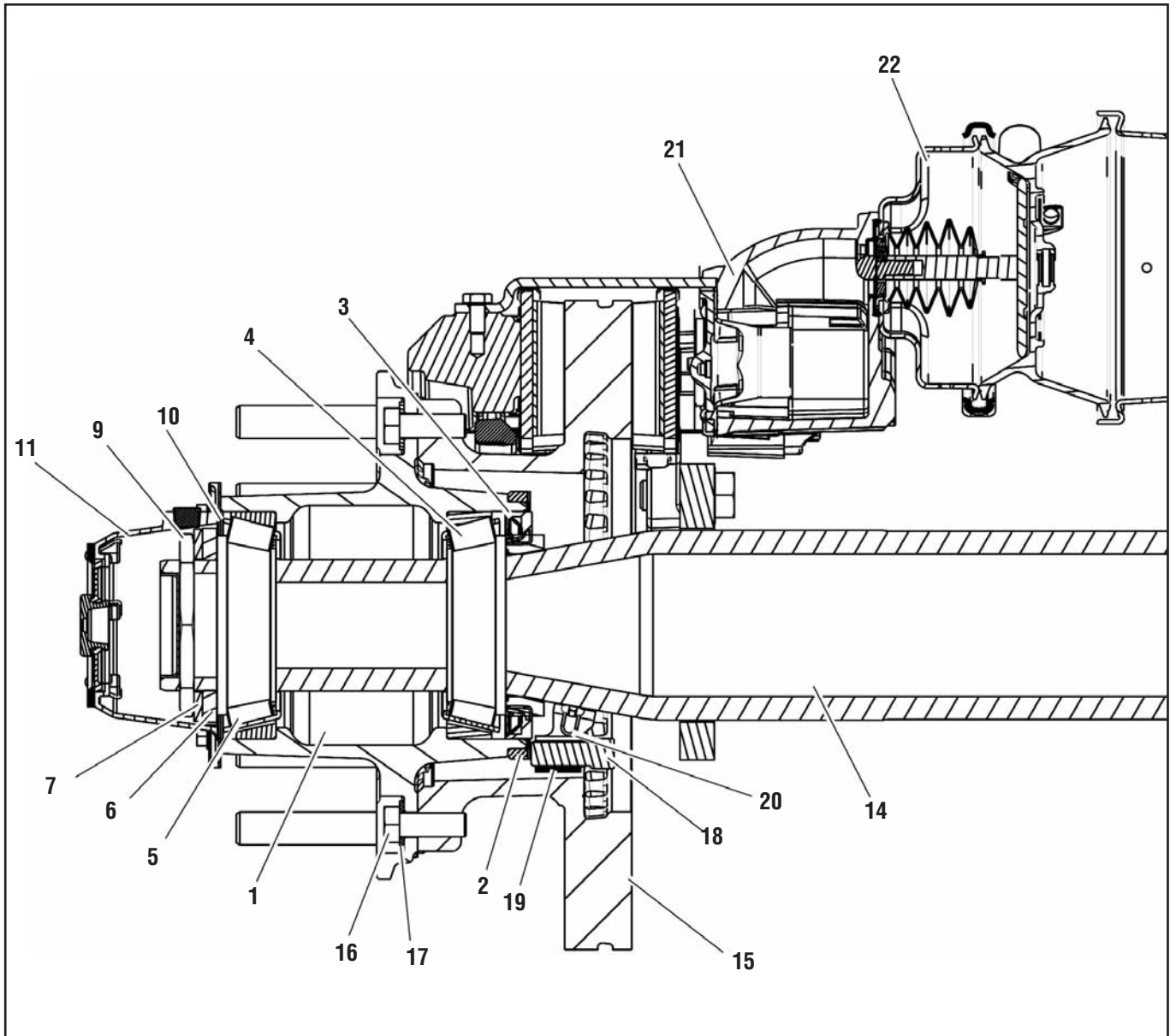

Item	Description	QTY (per axle)	Item	Description	QTY (per axle)
1	Hub	2	14	Axle Beam	1
2	ABS Pole Wheel	2	15	Rotor	2
3	Seal	2	16	Rotor Bolt	20
4	Inner Bearing	2	17	Hardened Washer	20
5	Outer Bearing	2	18	Sensor	2
6	Hub Adjusting Nut	2	19	Sensor Bush	2
7	Hub Locking Plate	2	20	Sensor Mounting Block (welded)	2
9	Hub Locknut	2	21	Air Disc Brake	2
10	Gasket	2	22	Actuator	2
11	Hub Cap	2			

2 Introduction

The Axle Identification Plate

Every axle leaving the Meritor factory is fitted with an identification plate which contains all the information needed to ensure correct replacement parts are obtained.

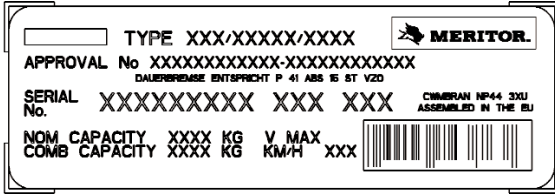

Identifying the Axle Type

All TP axles are fitted with 10 stud, ISO 4107 spigot mount wheel fixings and asbestos free brake pads or linings as standard. Other options are detailed below.

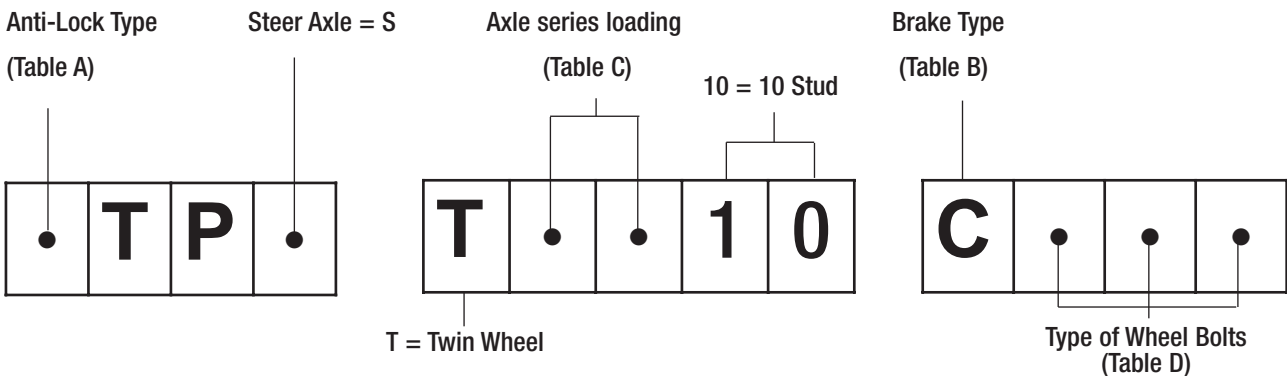

Table "A"

Axle Letter code	Exciter Ring Type	Suitable For
	100t / 80t Solid Ring	Wabco Bosch Grau DGX & MGX 100

Table "B"

Axle Letter Code	Brake Type
C	ELSA EX225L

Table "C"

Axle Series	Nominal Highway Rating, Kg	Wall Thickness	Max Offset *
90	9000	5/8 inch	460mm

Table "D"

Axle Letter Code	Wheel Mounting Type
MXA	M22x1.5p wheel studs for twin alloy wheels

* Offset = $\frac{\text{Track Spring Centres}}{2}$

** For use with Non Meritor air suspensions.
The axle ratings shown are for normal highway use only. Any special application must be approved by Meritor Technical Sales

Identifying The Serial Number

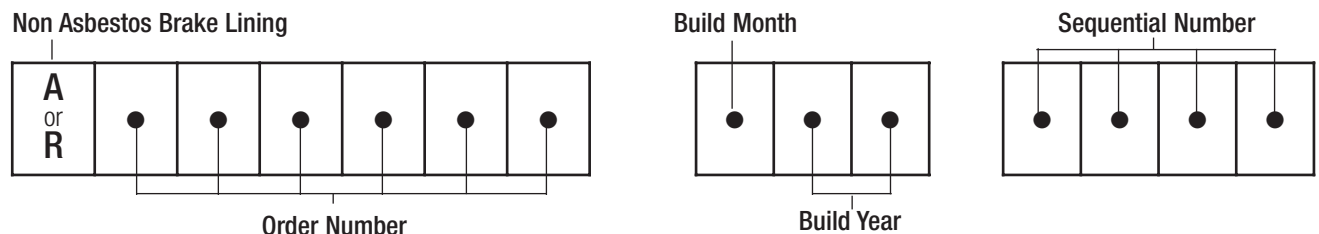

Inspection & Maintenance

3

pg. 16 Disc Brake Axles

pg. 16 Rotor Inspection

pg. 17 Rotor Run out

pg. 18 Rotor Wear Parameters

3 Inspection & Maintenance

Disc Brake Axles

Refer to the appropriate Meritor Inc. disc brake service manual for detailed disc brake inspection procedures.



CAUTION: You must always renew the brake pads on both wheels of an axle. Only use the brake pads that have been approved by the vehicle manufacturer. Brake pads must be replaced when the lining thickness has worn to 3mm minimum.

Rotor Inspection

Rotors should be examined in situ, whenever the brakes are serviced or new pads are fitted - or immediately if erratic braking performance is noted. The rotor condition should be visually checked for the following surface conditions, and replaced with a new rotor as described in **Section 5 Rotor Replacement** if suspect or defective.



CAUTION: You must always renew the rotor on both wheels of an axle. Only use the rotors that have been approved by the vehicle manufacturer.

Cracks (Fig 3.4)

Cracks that extend through to the vent of a ventilated rotor or 25% through the thickness at the outer edge of a solid rotor: Replace the rotor.

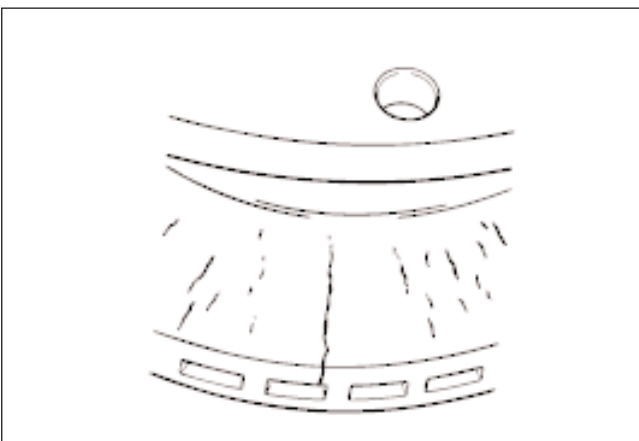

Fig. 3.4

Heat Cracking (Fig 3.5 & Fig 3.6)

Heat cracking is fine cracks on the rotor's surface. This is a normal condition that results from continuous heating and cooling of the friction surface. Braking under normal operating conditions can cause cracks to separate and deepen, increasing lining wear. There are two types of heat cracking: light and heavy.

Light Heat Cracking (Fig 3.5)

Light heat cracking is fine, tight cracks in the rotor's surface. Continue to use a rotor with light heat cracking.

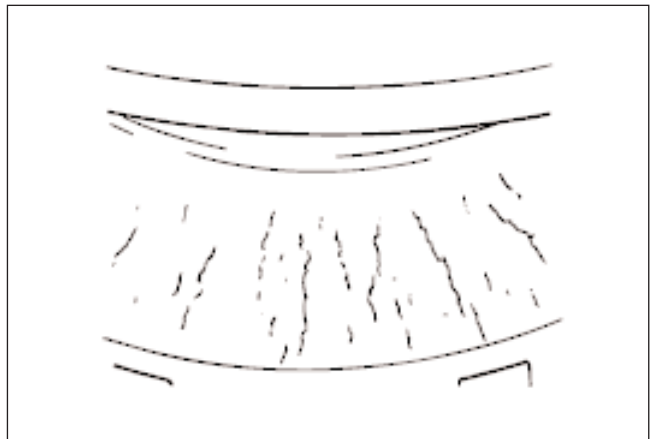

Fig. 3.5

Heavy Heat Cracking (Fig 3.6)

Heavy heat cracking is cracks in the rotor's surface that extend radially and have an individual length of up to 75% brake path width. Refinish or replace a rotor that has heavy heat cracking.

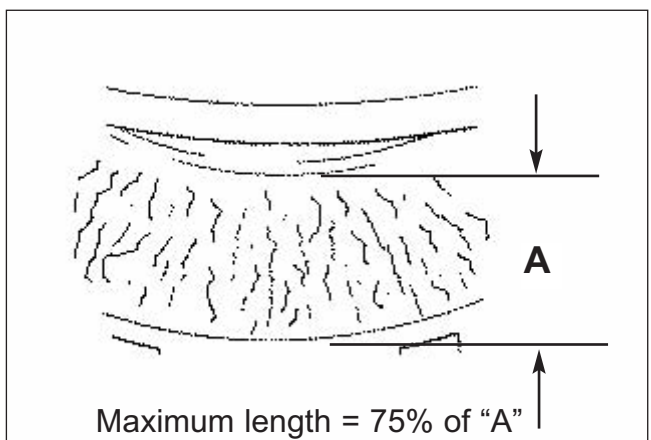

Fig. 3.6

NOTE: Surface finish after machining should be 5 microns maximum.

3 Inspection & Maintenance

NOTE: Localised crazing / blue patches / cracking in only one part of the rotor could be caused by rotor run-out or thickness variation. Refer to vehicle manufacturer for tolerances.

Scoring (Fig 3.7)

Scoring is deep circumferential grooves that can occur on both sides of the rotor's surface. If the groove or multiple scores are of a depth less than 0.5 mm, continue to use the rotor. If the groove / scores are greater than 0.5 mm, refinishing the rotor is recommended.

Refinishing the rotor is recommended before fitting new brake pads.

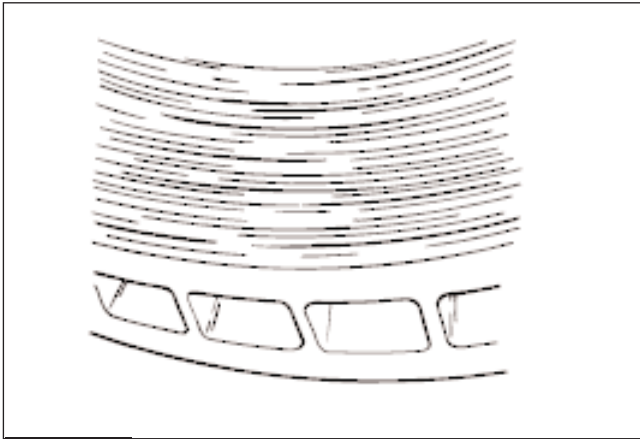

Fig. 3.7

"Blue" Rotor (Fig 3.8)

Blue marks or bands on the rotor indicate that extremely high temperatures occurred during operation. Refinishing the rotor is recommended before fitting new brake pads.

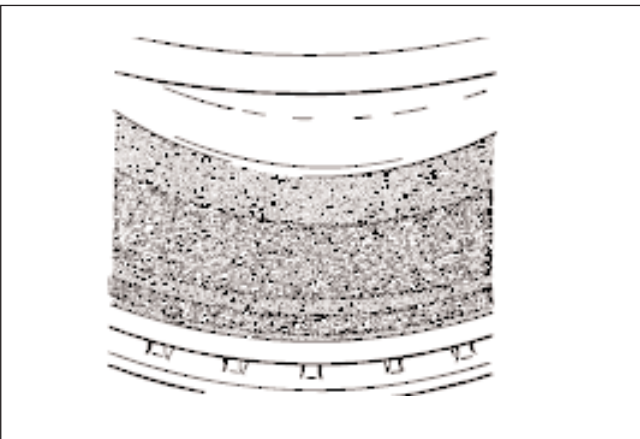

Fig. 3.8



CAUTION: Reasons for the excessively high temperatures must be investigated as this will adversely affect brake performance and lining wear rate. Continued operation at excessively high temperatures will eventually adversely affect brake function.

Rotor Run Out

Use a Dial test Indicator (DTI) to check the run-out both axially and radially as in (Fig. 3.9).

Axial

Run-out should not exceed 0.3mm over the rotor braking surface when the rotor is turned on properly adjusted wheel bearings. Excessive run-out may be due to incorrect mounting of the hub, fastener torque's or mal-adjusted bearings.

Radial

Run out should not exceed 0.8mm total indicator reading.

Thickness

Rotor thickness must not vary by more than 0.13mm across any two points of the rotor faces.

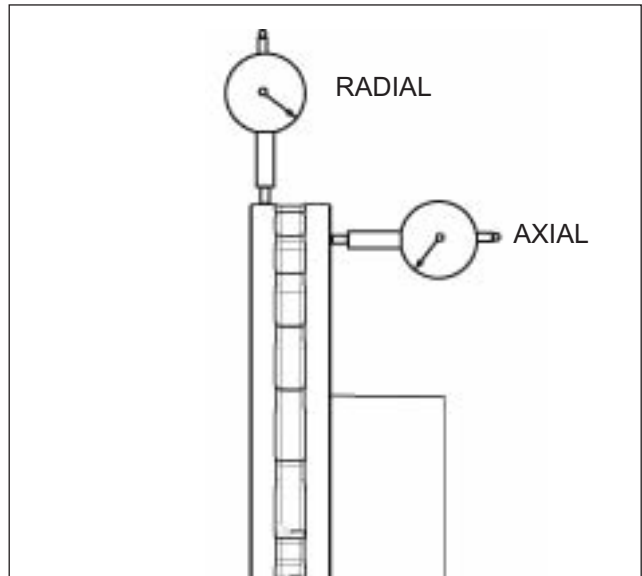

Fig. 3.9

3 Inspection & Maintenance

Rotor Wear

This section explains safe working practices for the limitations of a rotor life for the ELSA-EX225L Meritor Inc. Air Disc Brake, with a pad back plate thickness of 9mm or above.

Dimension Detail

New Rotor Thickness - A	45mm
Minimum Resurfacing Thickness	41mm
Minimum Fully Worn Thickness - B	39mm
Pad Back Plate Thickness	9mm
Carrier Rotor Gap - C	50mm
Minimum Friction Material Thickness	3mm
Clearance New Rotor - E	2.5mm

New Rotor Condition Fig 12.1

The rotor nominal maximum thickness (new condition) is **A**.

The rotor gap between the carrier abutments of the brake assembly is **C** nominally.

Therefore, if the rotor is central to the carrier abutments an equal clearance of **E** nominally is achieved either side of the rotor.

However, due to tolerances the rotor is not always central to the carrier abutment gap and this may result in the rotor requiring to be replaced before being worn to the minimum thickness.

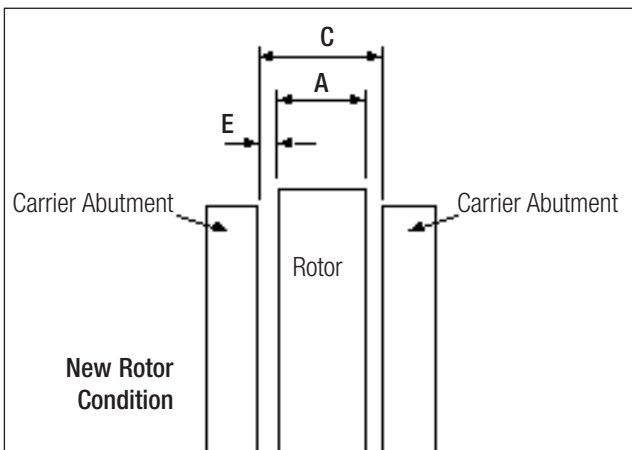

Fig. 12.1

Maximum permissible Rotor Wear Fig 12.2

The rotor is permitted to wear to a minimum thickness of **B** provided that there is maximum wear of no more than 3mm off any one rotor face. When equal wear is achieved on both sides of the rotor, the rotor maintains a central position in the carrier abutments. The rotor to carrier clearance **F** must not exceed 5.5mm.

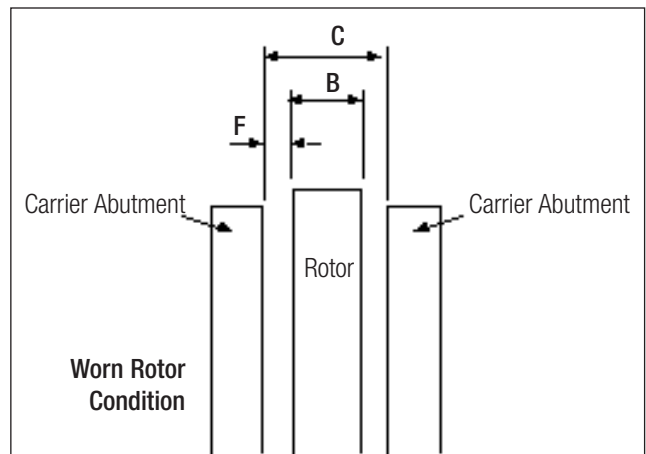

Fig. 12.2

Uneven Rotor Wear Fig 12.3

In many cases where uneven wear **D** takes place the rotor is required to be replaced before wearing down to the minimum thickness **B**. In the case of uneven rotor wear it is important that the gap between rotor and carrier abutment **F** must not exceed 5.5mm.

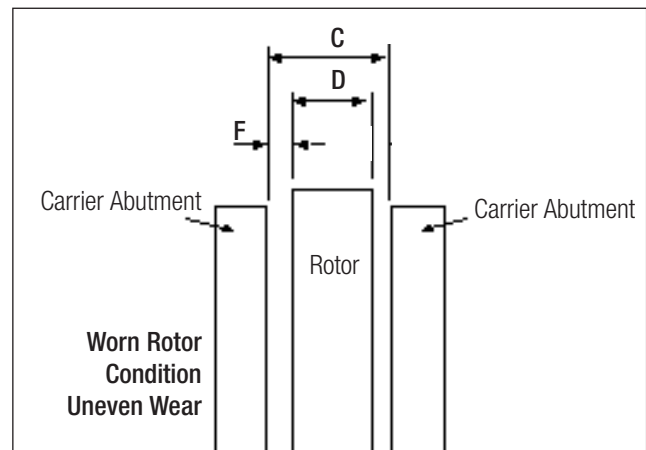

Fig. 12.3

3 Inspection & Maintenance



CAUTION: You must always renew the rotor on both wheels of an axle. Only use the rotors that have been approved by the vehicle manufacturer.



WARNING: To ignore these recommendations could result in severe damage to the wheel end assembly due to heat damage from metal pad back plate contacting the rotor.

To wear the pad back plate down to a thickness where it is possible to be trapped between carrier abutments and rotor could cause the wheel to lock at best and pad back plates to come out of the brake assembly at worst.

If these recommendations are not followed this negates any warranty claim and Meritor Inc. cannot be held responsible for operator neglect.

Hub Service & Replacement

4

pg. 22 Hub removal
pg. 23 Hub refitment

4 Hub Service & Replacement

Hub Removal

The TP axle fitted with a disc brake would normally only require hub removal if it is necessary to replace the rotor. Should it however prove necessary to remove the hub, the following procedures can be performed.

Raise the vehicle enough to get clearance to remove the wheel and tyre. Support the axle with safety stands. Remove the wheel and tyre.



WARNING: Do not work under a vehicle supported only by jacks. Jacks can slip or fall over can cause serious personal injury. Support the vehicle with safety stands, block the wheels to prevent the vehicle from moving.

NOTE: Comprehensive Disc Brake instructions can be found in the appropriate MeritorHVS Service Manual detailed below:

Elsa EX225L MM 0350

De-adjust the brake.



WARNING: Always de-adjust/adjust the brake carefully by hand with a suitable wrench. Never exceed the maximum torque specified for the type of disc brake in either direction and NEVER use power tools.

Remove the brake pads and air chamber.

Remove the brake assembly mounting bolts. Take care not to allow the brake assembly to fall (Fig 4.1). Remember that the brake assembly has a weight of up to 55kgs.

Lift the brake assembly away from the axle.

REMOVAL OF HUB

Remove the five M8 hub retaining screws. Remove hub cap and gasket (Fig. 4.2). Remove the socket head screws using 5mm A/F Allen key (Fig. 4.3).



WARNING: The hub locknut and adjusting nut should be removed using suitable size sockets ($\frac{3}{4}$ " drive recommended) . Do not attempt to loosen/remove by striking the nut using a chisel or drift. Damage to the components will occur causing possible loss of wheel end retention and personal injury.

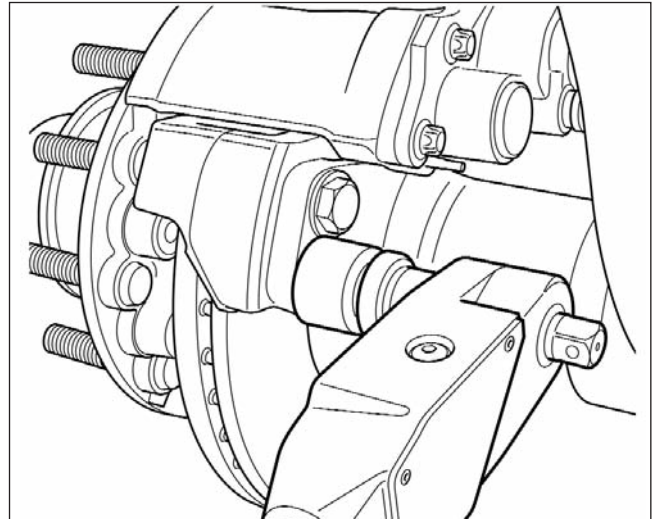

Fig. 4.1

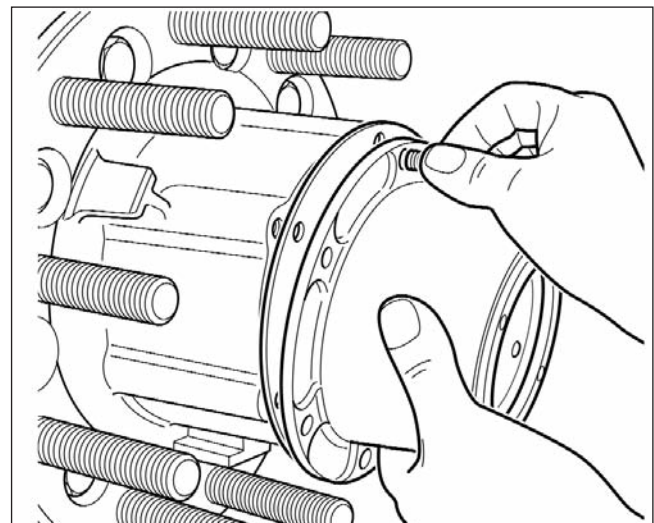

Fig. 4.2

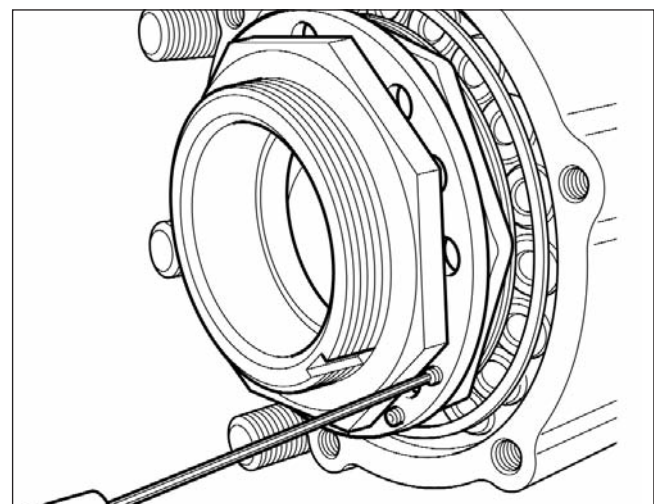

Fig. 4.3

4 Hub Service & Replacement

Remove the hub locknut, locking plater and adjusting nut (Fig. 4.4)..

Remove the outer bearing cone (Fig 4.5) and place it in a clean area.

Identify the bearing cone clearly to ensure that it is refitted to its original position in the hub.

Remove the hub and rotor assembly from the axle (Fig 4.6).

REMOVAL OF INNER BEARING CONE

Remove the inner bearing cone (Fig 4.7) and place it in a clean area. Identify the bearing cone clearly to ensure that it is refitted to its original position in the hub.

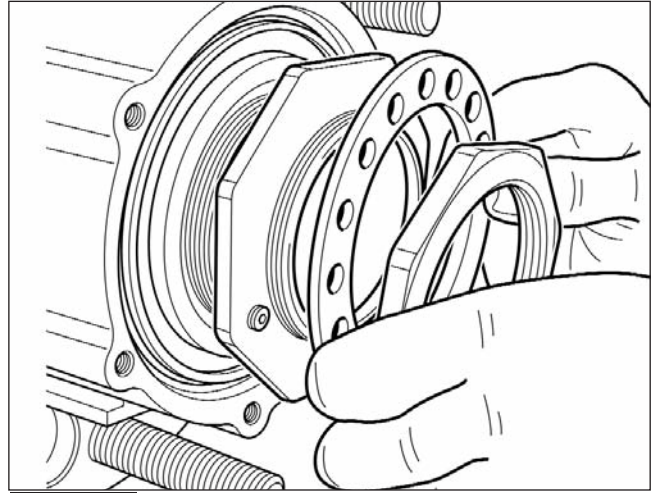

Fig. 4.4

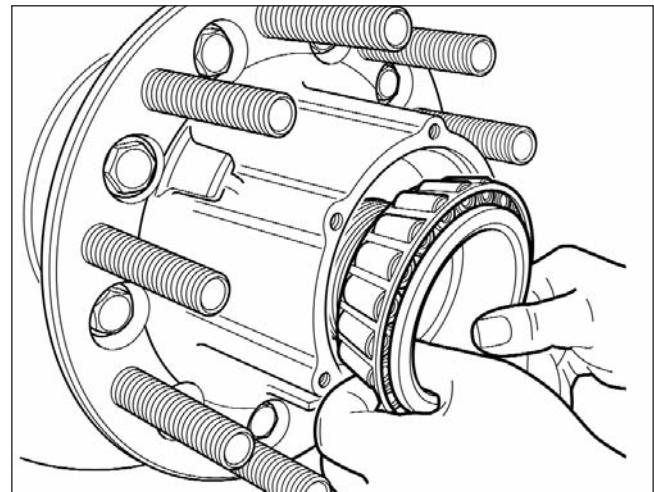

Fig. 4.5

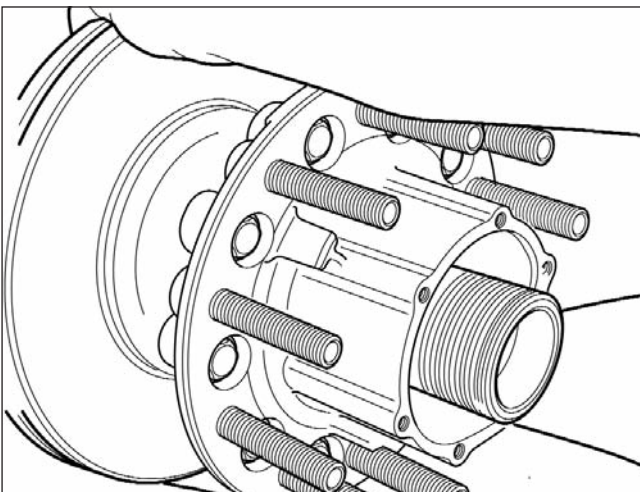

Fig. 4.6

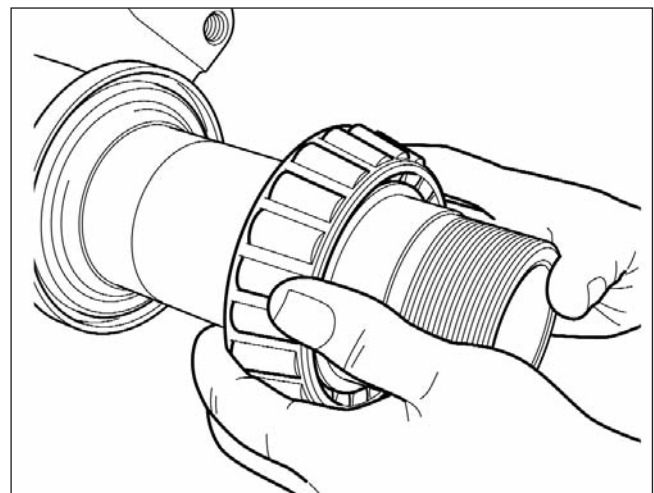

Fig. 4.7

4 Hub Service & Replacement

REMOVAL OF HUB SEAL

Remove the hub seal from the axle spindle and discard.

Loosen the seal by lightly tapping the metal seal collar with the round end of a ball-peen hammer (Fig. 4.8). Remove the seal and discard.

NOTE: An alternative method to remove the seal is to use a suitable slide hammer with a hook attachment (Fig. 4.9).



CAUTION: Ensure the axle spindle is not damaged when removing the oil seal.

CHECK GREASE CONDITION

If the grease within the bearing is clean and does not appear burnt there should be no necessity to totally clean down the assembly.

Check the hub cavity for any grease contamination caused during hub removal from the spindle. Any contamination must be removed or if this is excessive a complete hub clean down must be carried out.

CLEANING OF HUB

Wipe clean the hub cavity removing all the old grease and any contamination.



CAUTION: Ensure any grease removed from the assembly/components, or contaminated cloth, is disposed of in accordance with local environmental regulations.

INSPECT BEARINGS

Check both bearings, cones and raceways for:

Cage damage Corrosion Roller and raceway damage or pitting
Metallic debris or flaking Bearing cup security - Ensure both bearing cups are well secured in the hub, by checking they are fully seated within the hub bore, and with a good grip of the cups try to rotate them. If any movement of the cups is detected then the hub will have to be replaced. Do not attempt to fit new bearings into a hub with worn bores.

If any of the above defects are evident the complete bearing (cup and cone) MUST be replaced.

NOTE: It is advisable to replace with a complete new hub and bearing assembly which is available from Meritor CVA Distributors.

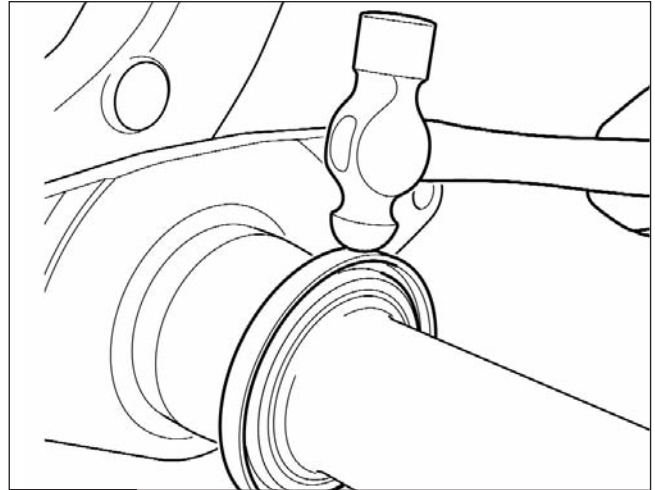

Fig. 4.8

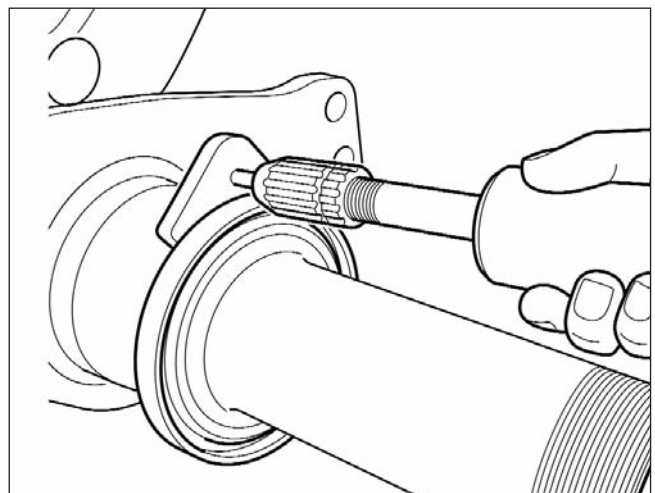

Fig. 4.9

INDIVIDUAL BEARING REPLACEMENT PROCEDURE

Drift out the bearing cup from the hub ensuring that the bearing bore within the hub is not damaged.

BEARING CUP REFITMENT

Ensure the hub cavity is clean and free from visual damage, debris, burrs or any oxidation.



CAUTION: The bearing 'Cups' and 'Cones' are clearly marked by manufacturer type for identification. Never assemble a bearing using a 'Cup' from one manufacturer with a 'Cone' from a different manufacturer. Always check the bearing components are from the same manufacturer before assembly continues.

4 Hub Service & Replacement



CAUTION: Always use genuine MERITOR Bearings - STANDARD ISO BEARINGS CANNOT BE USED.

Insert the bearing cup into the hub and using a bearing cup driver (Meritor CVA part number MST 3103) drive the cup fully home ensuring the cup sits squarely against the hub shoulder.

Check the bearing cup is retained correctly. Grip the bearing cup and ensure there is no axial or rotational movement present.

REGREASE BEARINGS

Thoroughly pack both bearing cones with Meritor Hub Grease, Blue Lithium EP2. The grease should be concentrated in the space between the roller cage and cone raceway. Refer to **Section 9** for correct grease quantities

Refill the bearing cavity with Blue Lithium EP2. Refer to **Section 9** for correct grease quantity.

NOTE: Greased bearings should always be placed in a clean area.



CAUTION: Only use the grease supplied with replacement components/kits, or that specified.

Under no circumstance should any other type of grease be used.

TP Hub Re-Fitment Procedure

CLEAN SPINDLE BEARING JOURNAL

Prior to re-assembling the hub onto the spindle, check the spindle for damage and remove any fretting or rust on bearing journals using medium grade emery cloth strip. Also ensure the inner bearing abutment shoulder is clean and free from damage.

Clean the oil seal journal, removing brake dust or corrosion from adjacent areas.

CHECK SPINDLE END THREAD

Any minor damage can be repaired using a 12 TPI thread chaser.

FIT NEW OIL SEAL

Apply 15 - 20gm of Meritor Hub Grease, Blue Lithium EP2 to the cavity of the new seal, working the grease in evenly around the circumference of the seal.

Apply a light smear of Meritor Hub Grease, Blue Lithium EP2 to the bore of the oil seal.

Fit the new oil seal onto the axle spindle. Ensure the seal is in the correct orientation with the seal marking 'OIL SIDE' facing the hub (Fig. 4.11).



CAUTION: Do not fit the new oil seal into the hub.

Using the correct oil seal driver (Stemco Part No. 015525239) carefully drive the seal into position (Fig 4.12) until the service tool bottoms against the bearing shoulder (Fig. 4.12). Wipe off any excess sealant.

NOTE: The metal oil seal collar **A** must be flush with the bearing shoulder **B** (Fig. 4.12).

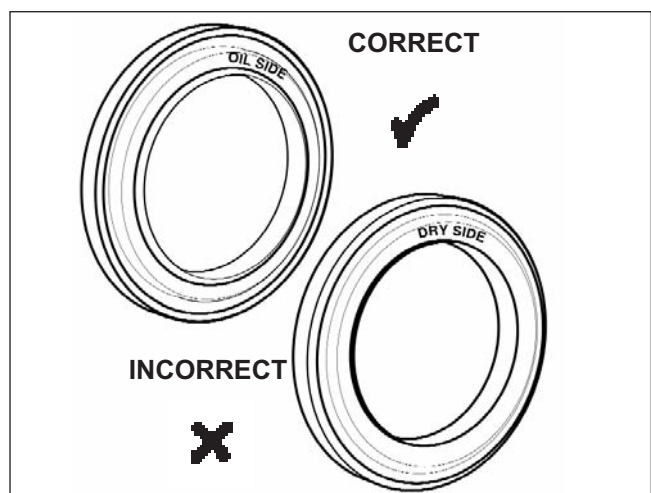

Fig. 4.11

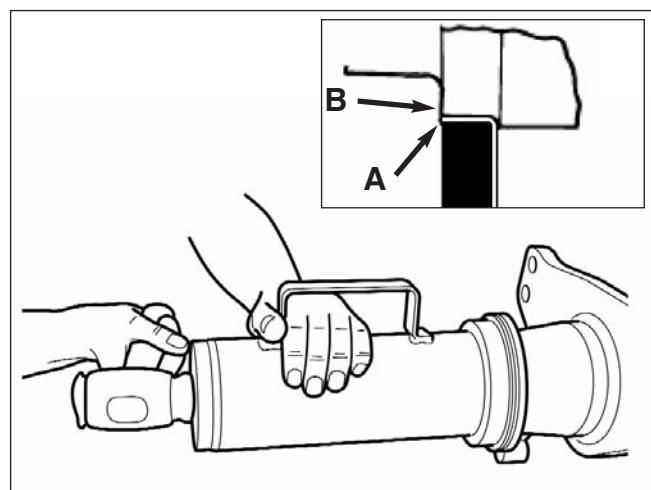

Fig. 4.12

4 Hub Service & Replacement

Apply 1 to 2 grams (volume 1 to 1.5 cm³) of Optimol 'Optimoly White Paste T' to the axle spindle in the area 'A' (Fig 4.12). Refer to **Section 9 Lubricants** for the Meritor CVA Optimol part numbers.

Spread the grease evenly around the spindle's circumference using a suitable soft brush. Using the excess grease on the brush, apply an even film around the circumference of the bearing journal shoulder, area 'B' (Fig 4.12). This will reduce spindle wear and assist future removal of the hub assembly.



CAUTION: Only use the grease supplied with replacement components/kits, or that specified.

Under no circumstance should any other type of grease be used.

RE-MOUNT HUB ASSEMBLY

If the axle is fitted with ABS:

Check the condition of the sensor and push it fully forward on its mounting block.

Refit inner bearing cone into the inner bearing cup pressing fully home.

Check the hub cavity grease and top up as necessary with Meritor Hub Grease, Blue Lithium EP2. Refer to **Section 9** for correct grease quantity.

NOTE: The grease must be distributed evenly within the cavity between the inner and outer bearings. Ensure the bearing bore/s are clean and free from any excess grease.

Push the hub and rotor assembly onto the axle spindle. Push the assembly fully onto the spindle taking care not to damage the oil seal or spindle threads.

Apply 0.5 to 1 grams of Optimol 'Optimoly White Paste T' to the outboard bearing bore and spread evenly around the circumference. Refer to **Section 9 Lubricants** for the Meritor CVA Optimol part numbers.

Refit the outer bearing cone (Fig 4.13).

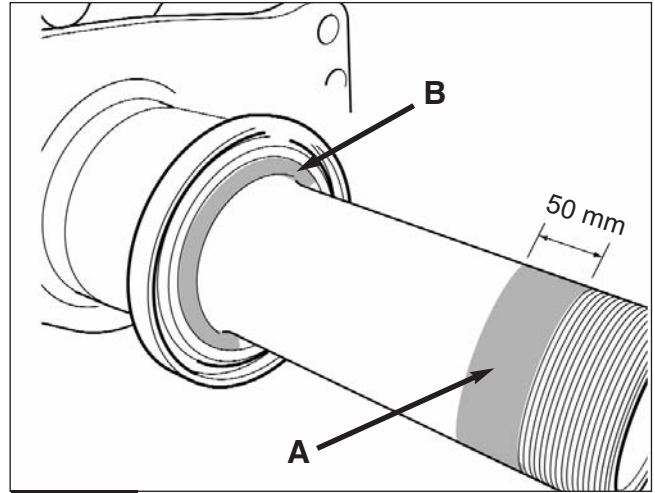

Fig. 4.12

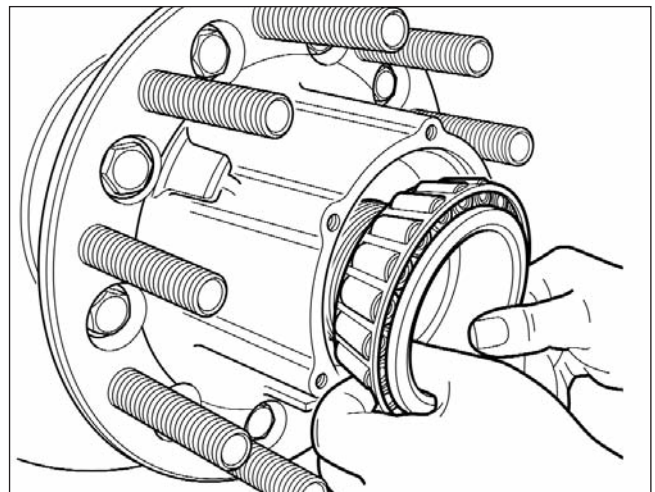

Fig. 4.13

4 Hub Service & Replacement

REFIT ADJUSTING NUT

Fit the hub adjusting nut, ensuring the alignment pin **A** is facing outwards (Fig. 4.14) and tighten **using a suitable size socket** ($\frac{3}{4}$ " drive recommended), until the nut abuts the bearing cone.

HUB ADJUSTING NUT SETTING PROCEDURE

- T** Tighten the nut to 271 Nm, while rotating the wheel end in both directions (Fig. 4.15).
- T** Completely loosen the nut, then tighten it to 68 Nm, while rotating the wheel end.

Loosen the nut 1/4 turn. Do not include socket backlash in the 1/4 turn.

Install the hub locking plate. If the hole in the locking plate is not aligned with the adjusting nut pin **A**, remove the locking plate, turn it around and reinstall. The pin and hole should now be aligned. If not, slightly adjust the parts to align them. (Fig. 4.16).

- T** Fit the hub locknut and tighten **using a suitable size socket** ($\frac{3}{4}$ " drive recommended), to 340-408 Nm (Fig. 4.17).

⚠ CAUTION: Too loose an adjustment will reduce bearing life, increase spindle wear and cause seal leaks. Too tight an adjustment will reduce bearing life and increase spindle wear. Extremely tight adjustments can cause complete bearing failure and possible loss of wheel-end equipment.

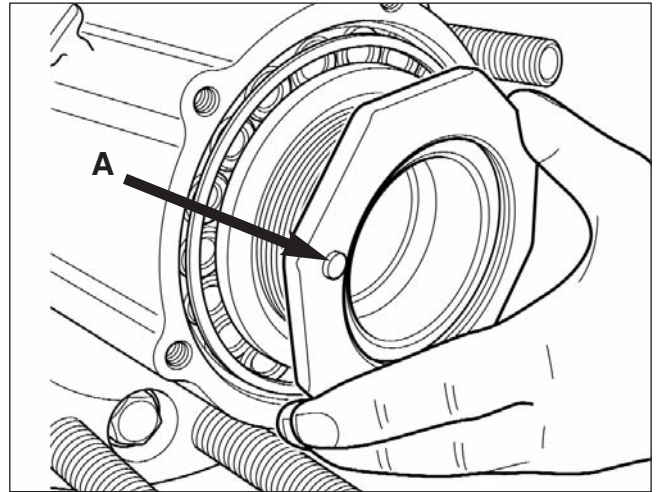

Fig. 4.14

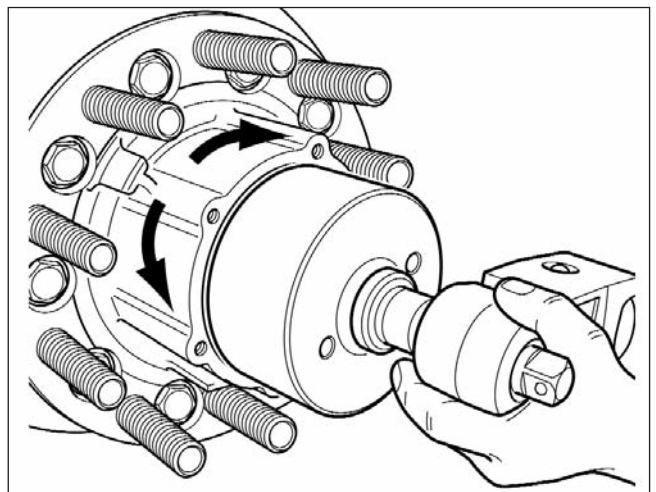

Fig. 4.15

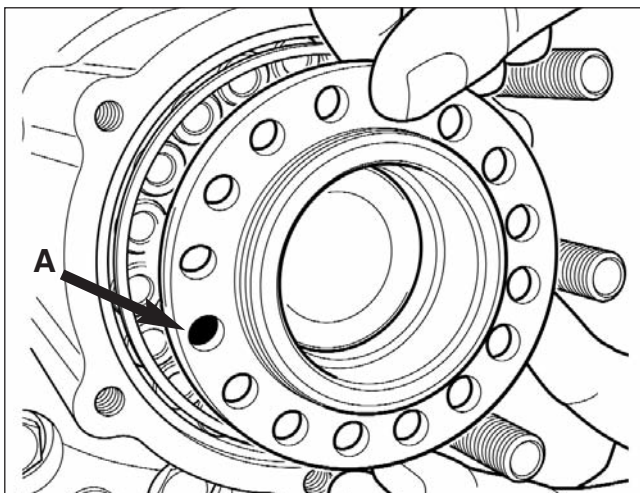

Fig. 4.16

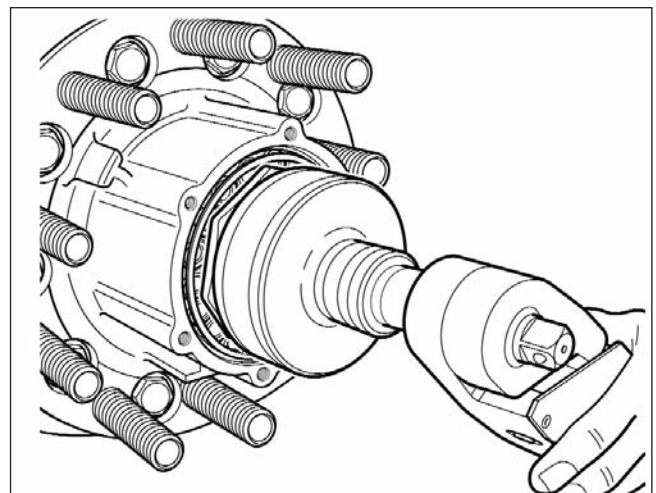

Fig. 4.17

4 Hub Service & Replacement

Check the wheel bearing end play as follows.

- A. Attach the magnetic base of a dial indicator to the spindle. Touch the dial indicator stem to the hubcap gasket face. (Fig. 4.18).
- B. Slightly rotate the wheel end in both directions while pushing inward until the dial indicator does not change. Set the dial indicator to ZERO. (Fig. 4.19).
- C. Slightly rotate the wheel end in both directions while pulling outward until the dial indicator does not change. (Fig. 4.20).
- D. End play is the difference between the two readings.



WARNING: You must adjust wheel bearing end play to within 0.001-0.005-inch (0.025-0.127 mm). An adjustment that is too loose will reduce wheel-end bearing life, increase spindle wear and cause seal leakage. An adjustment that is too tight can affect wheel-end bearing performance. Loss of wheel-end components, serious personal injury and damage to components can result.

If end play falls within 0.001-0.005-inch (0.025-0.127 mm), the bearing setting is correct. If end play does not meet this requirement carry out the following procedure.

Remove the hub locknut and locking plate.

Tighten or loosen the hub adjusting nut as required to achieve the correct end play.

Refit the locking plate.



Refit the hub locknut and tighten the to 340-406 Nm.

Check end end play again.

Continue to adjust/deadjust until the end play is within the within 0.001-0.005-inch (0.025-0.127 mm) tolerance value.

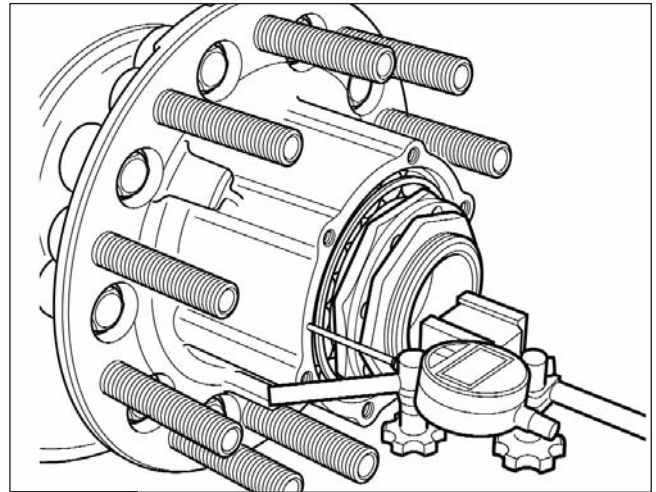

Fig. 4.18

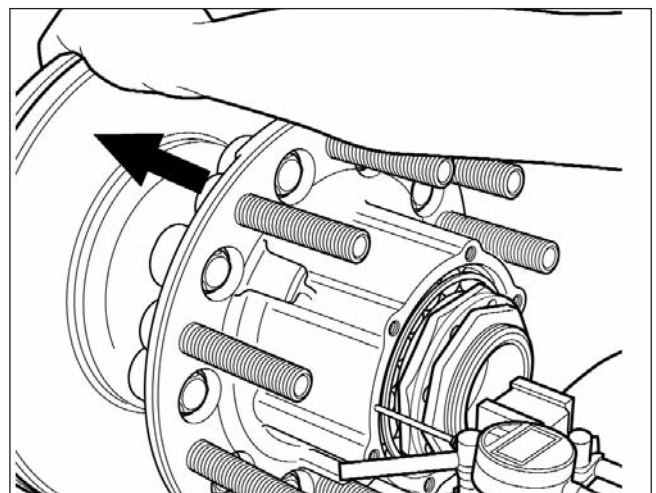

Fig. 4.19

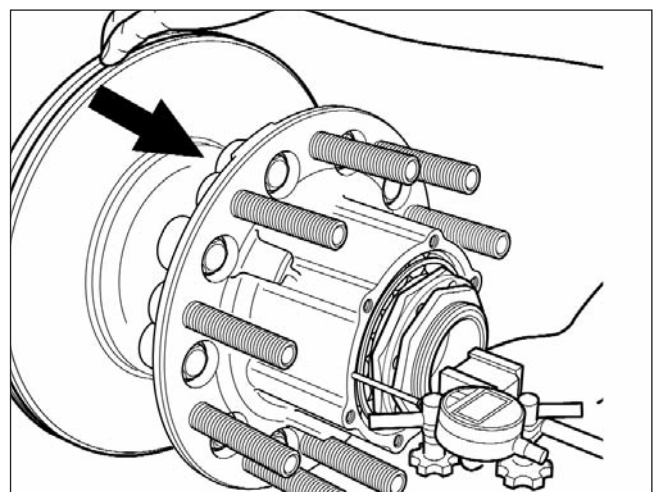

Fig. 4.20

4 Hub Service & Replacement

Fix the socket head screws to the hub locking plate and tighten until the head of the screw is flush with the face of the locking plate.

NOTE: The socket head screw includes a nylon thread locking patch. The locking properties of this patch are effective for two further applications of the screw after initial factory assembly. The screws should then be replaced.

Tighten the socket head screws to the torque value specified in **Section 9 Torque Values** using a 5mm A/F Allen socket and torque wrench (Fig 4.21)

REFIT HUB CAP

Check the gasket location area on the hub face is clean and fit the hub cap gasket and hub cap, align the hub cap retaining screw holes and fit the hub cap retaining screws (Fig. 4.22). Tighten the hub cap retaining screws evenly.

Finally tighten the hub cap retaining screws to the torque value specified in **Section 9**. Ensure the gasket is compressed evenly and not damaged (Fig 4.23).

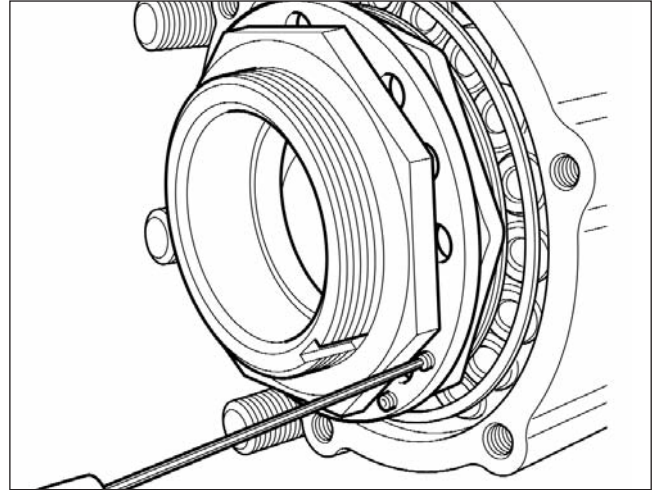

Fig. 4.21

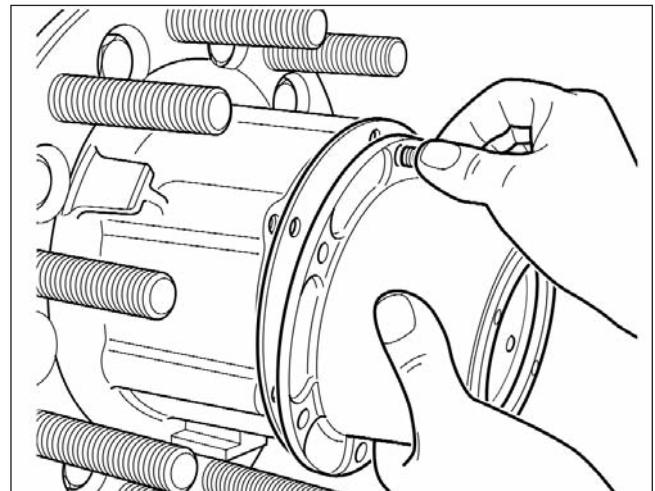

Fig. 4.22

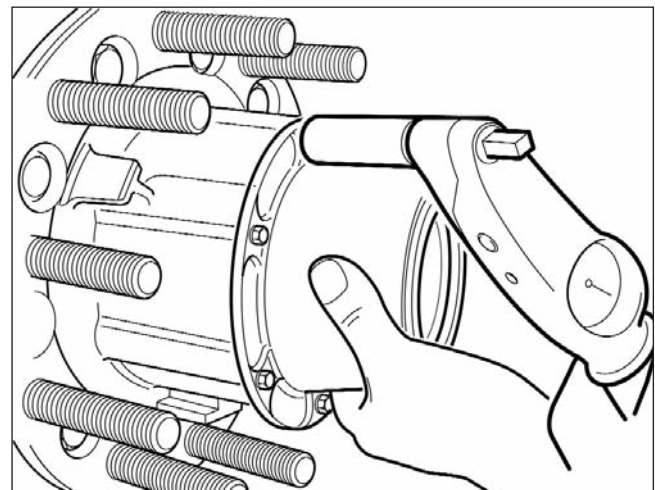

Fig. 4.23

4 Hub Service & Replacement

REFITTING THE BRAKE ASSEMBLY

Lift the brake assembly over the rotor.



CAUTION: Do not use the pad retaining plate or stabiliser bar, where applicable, for handling purposes. Damage to the disc brake components could result.

While supporting the brake assembly, align the brake assembly mounting holes with the fixing points on the axle torque plate. Fit the fixing bolts with hardened washers.

Take care not to allow the brake assembly to fall. Remember that the brake assembly has a weight of upto 55kgs.

Tighten the fixings, starting on the top half of the torque plate.

Tighten the fasteners to the torque value specified in **Section 9** using a suitable size socket (1/2" in drive recommended) (Fig. 4.24).

Refit the air chamber and brake pads as described in the appropriate Meritor Inc. Disc Brake service manual listed below:

Elsa EX225L MM 0350

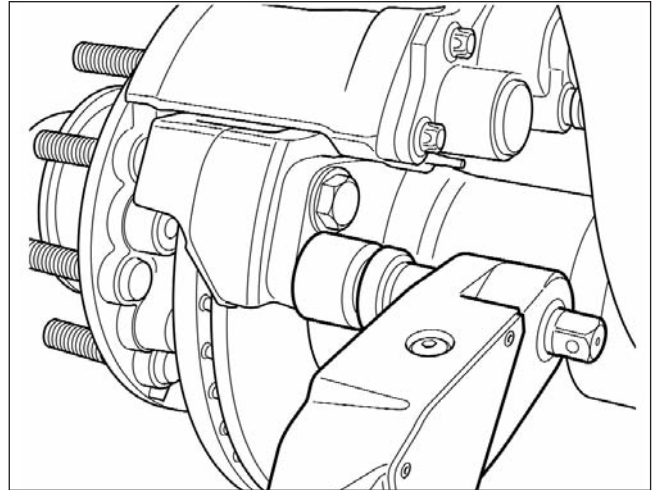

Fig. 4.24

Rotor Replacement

5

pg. 32 Rotor Removal
pg. 32 Rotor Fitment

5 Rotor Replacement

Rotor Removal



CAUTION: You must always renew the rotor on both wheels of an axle. Only use rotors that have been approved by the vehicle manufacturer.

Raise the vehicle enough to get clearance to remove the wheel and tyre. Support the axle with safety stands. Remove the wheel and tyre.



WARNING: Do not work under a vehicle supported only by jacks. Jacks can slip or fall over and cause serious personal injury. Support the vehicle with safety stands, block the wheels to prevent the vehicle from moving.

Loosen the nuts securing the rotor to the hub assembly, **DO NOT REMOVE AT THIS STAGE**

Remove the Hub as described in **Section 4 Hub Removal & Replacement**

Place the hub on a suitable flat clean surface with the rotor facing up and remove the rotor securing nuts/washers. Lift the rotor from the hub and discard.

Rotor Fitment

Place the new rotor loose on its hub mounting spigot and align the fixing holes.

By hand fit at least two opposite rotor mounting bolts and washers before turning the assembly over (Fig 6.1).



Fit the remaining fasteners and hardened washers. Apply a nominal torque of no more than 30 Nm to all fasteners to seat the rotor. Check the correct length of bolt has been used in all 10 positions.

Refit the Hub and rotor assembly as described in **Section 4 Hub Removal & Replacement**

Tighten the rotor securing nuts to the correct torque specified in **Section 9 Torque Values**

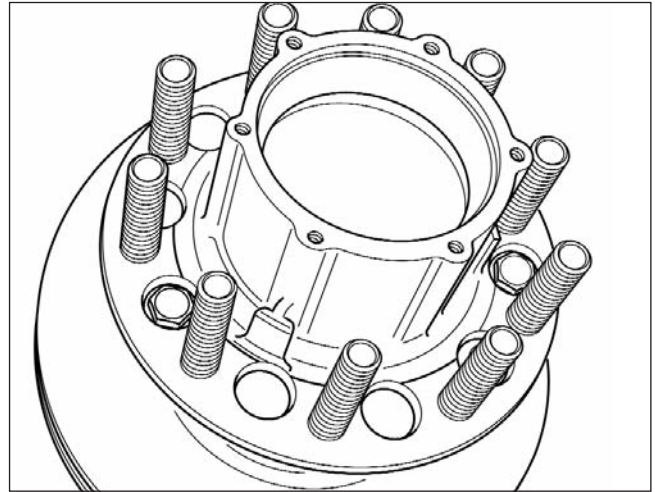

Fig. 6.1

ABS Component Replacement

6

pg. 34 ABS Pole Wheel Replacement

pg. 35 ABS Sensor Replacement

pg. 35 Checking Sensor Output

6 ABS Component Replacement

ABS Pole Wheel Replacement

ABS Pole Wheel Removal

Remove the hub assembly and bearings as described in **Section 4 Hub Service & Replacement**.

With the hub removed from the axle, and bearings removed from the hub, remove the rotor as described in **Section 5 Rotor Replacement**.

Using a suitable puller, or slide hammer, remove the ABS pole wheel from the hub mounting spigot.



CAUTION: Do not damage the hub during the ABS pole wheel removal.

ABS Pole Wheel Fitment

Place the hub, with the inner bearing side upwards, on a clean, flat surface and cover the bore with a clean cloth to protect the from contamination.

Check that the pole wheel mounting spigot on the hub is clean and free from rust using medium emery paper to clean it up if necessary. Ensure no emery dust or other debris contaminates the bearings or grease.

The pole wheel can be fitted hot or cold using the oil seal driving tool (Meritor CVA Part No. MST 3106). If fitting hot, heat the pole wheel evenly to a maximum of 150°C using a hot plate or induction heater and place onto the hub spigot ensuring it fully seats. If fitting cold, use the oil seal driving tool to drive the pole wheel onto the hub spigot ensuring it bottoms out against the mounting shoulder (Fig. 6.1).

Refit the rotor as described in **Section 5 Rotor Replacement**.

Refit the hub assembly and bearings as described in **Section 4 Hub Service & Replacement**.

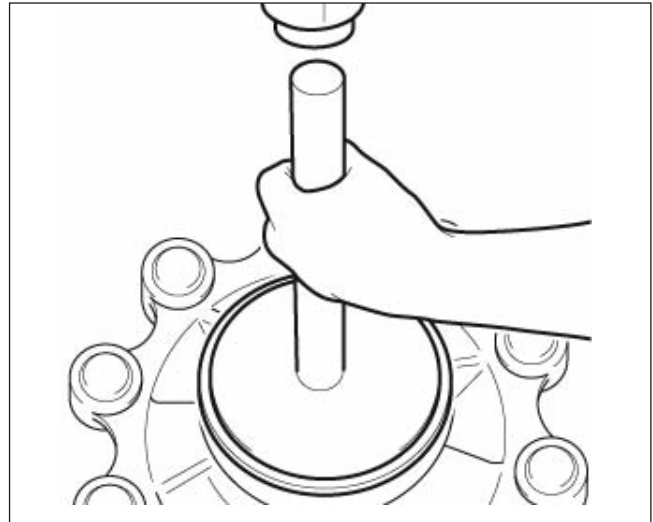

Fig. 6.1

6 ABS Component Replacement

ABS Sensor Replacement

NOTE: For TP axles the sensor mounting block is welded to the axle beam (Fig. 6.2)

ABS ensor Removal

Disconnect the sensorwiring from the vehicle wiring harness. Carefully remove the sensor from the axle mounting block and discard. Remove the sensor bush from the axle mounting block and discard.

ABS Sensor Fitment

Apply Meritor Brake Lubricant grease to the spring bush.

Fit the spring bush into the sensor mounting block (Fig. 6.3).

Push the sensor fully into the mounting block. Check when the hub and rotor has been fitted and that the sensor has been pushed up to the pole wheel (Fig 6.4).

NOTE: When the hub is refitted the pole wheel will push the sensor back thus attaining the correct clearance.

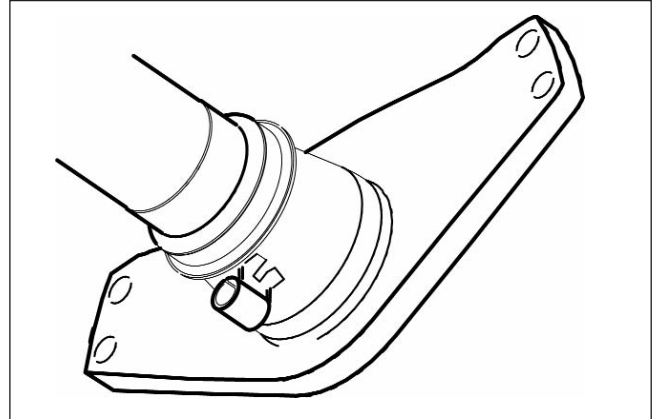

Fig. 6.2

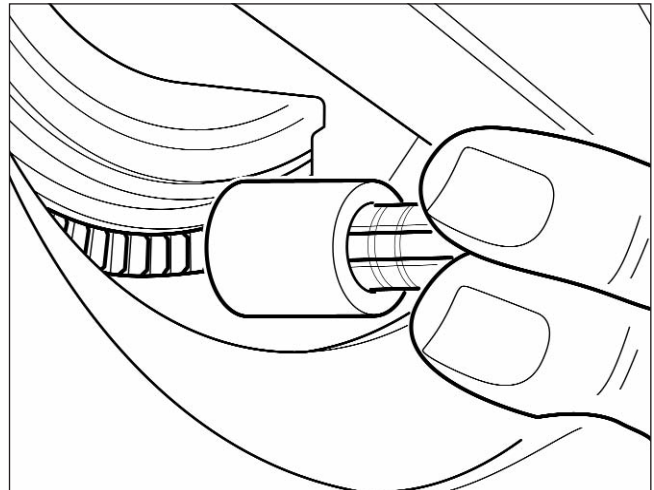

Fig. 6.3

Checking Sensor Output

Connect the output cable to a suitable multimeter.

Rotate the hub by hand at a constant rate of approximately 30 rpm and note the maximum and minimum readings.

The minimum permissible voltage reading is 400 millivolts and the ratio of maximum/minimum should not exceed 2.

If either values are not obtained check the installed air gap between the sensor and pole wheel does not exceed 0.7 millimeters and the pole wheel run out does not exceed 0.2 millimeters.

If the installation is still not correct, contact the supplier of the ABS equipment for further advice.

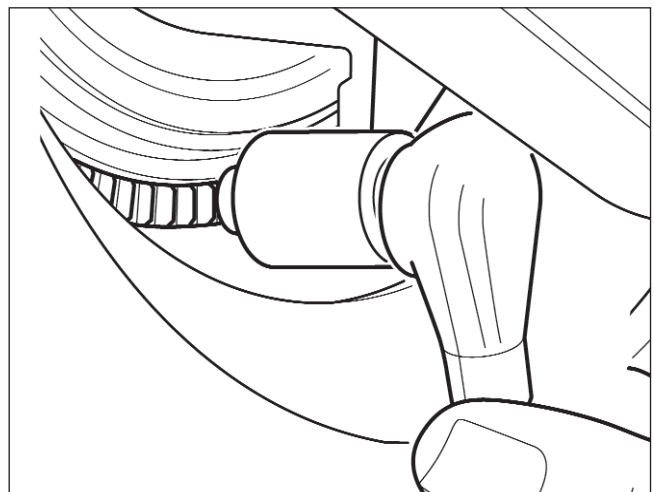

Fig. 6.4

Hub Odometer Replacement

7

pg. 37 Hub odometer fitment

7 Hub Odometer Replacement

Hub odometer Fitment

The TP/LC axle may be fitted with a hubodometer by using a special hub cap (Fig 7.1).

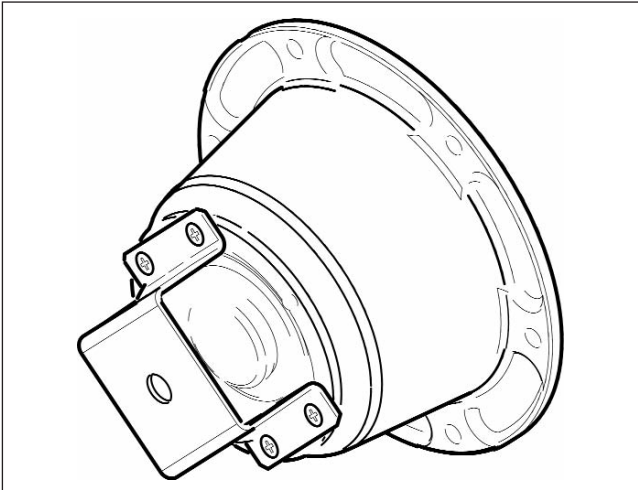

Fig. 7.1

It is not possible to fit an hubodometer to a standard hub cap (Fig 7.2) and attempting to do so will affect the hub sealing and may damage the spindle.

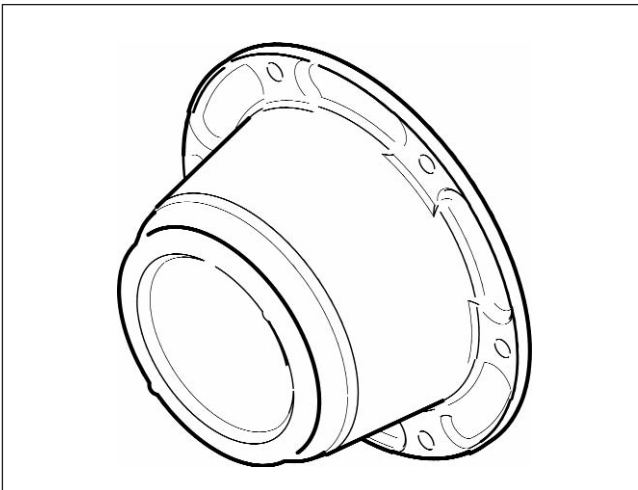

Fig. 7.2

For hubodometer types up to 85mm outside diameter use hub cap Meritor Part No. 21224904.

It is advisable to assemble the hubodometer to the hub cap prior to fitting the hub cap to the axle. Where applicable remove the hub cap from the hub as described in **Section 4 Hub Service & Replacement**

Place the hub cap on a clean, flat surface. Fit the nut to a suitable open ended spanner and using a small amount of grease place the washer onto the nut.

Using the spanner, position the nut and washer under the mounting hole in the cross bar of the hub cap.

T Lower the hubodometer through the hole to engage the thread. Rotate the hubodometer to screw the nut along the mounting stud until hand tight. Finally tighten the nut with the spanner in the normal way to a maximum of 27 Nm.

The hub cap and gasket can now be fitted to the axle as described in **Section 4 Hub Service & Replacement**.

Wheel Bolt Replacement

8

pg. 39 Removal & Fitting wheel bolts

8 Wheel Bolt Replacement

REMOVAL AND FITTING WHEEL BOLTS

With the hub removed from the axle, support it by placing blocks under the flange. Using the wheel bolt removal tool (Meritor CVA Part No. MST 3211) drive out the wheel bolts (Fig. 8.1)

Wind the new stud into the hub using spacer washers and a wheel nut. Ensure the gap under the bolt head does not exceed 0.1mm. (Fig. 8.2)

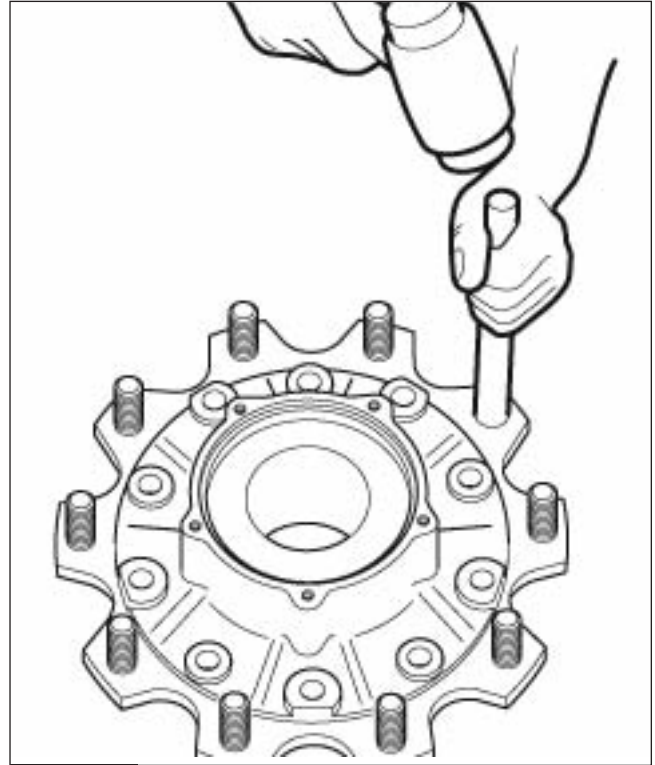

Fig. 8.1

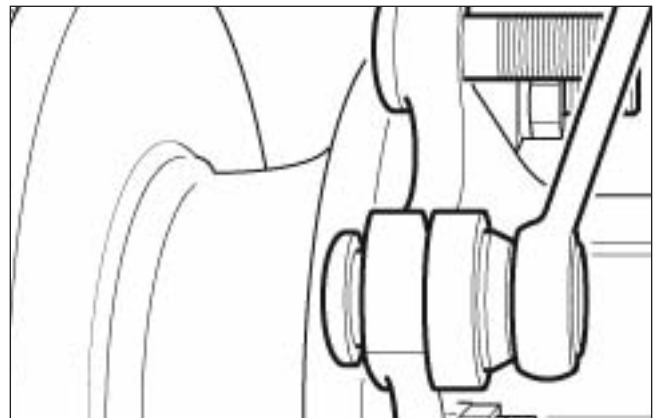

Fig. 8.2

Maintenance schedules Torque Values Lubricants & Grease volumes

9

pg. 41 Maintenance schedules
pg. 42 Torque values
pg. 42 Recommended lubricants
pg. 42 Grease fill volumes

9 Maintenance schedules, Torque Values, Lubricants & Grease volumes

Maintenance schedules

Check Brake Adjustment & Wheel Nut Torques;

- Before entering service.
- After 150 km.
- After 1500 km.
- Every 3 months.
- After any wheel fixing removal.
- After any brake service.

Hub and Bearing Inspection, Including Oil Seal Replacement;

- Whenever hubs are removed from axle.
- Annually after 1st major hub overhaul.

Major Hub Service;

- If a problem is found during inspection.
- Prior to 2nd annual test or after 300,000 km, whichever occurs first.

9 Maintenance schedules, Torque values, Lubricants & Grease volumes



Torque Values

Hub cap bolts	11 - 15 Nm
TP Axle lock nut	Refer to setting procedure, Section 4
Socket head screw (axle lock nut)	15 - 20 Nm
Wheel nuts	680 - 750 Nm
Rotor flange bolts	210 - 265 Nm
Brake assembly retaining bolts	540 - 675 Nm
Air chamber nuts:	
Tighten evenly to initial torque of	80 - 100 Nm
Retighten to a final torque of	180 - 210 Nm

Recommended Lubricants

Hub Bearings:

Meritor Hub Grease, Blue Lithium EP2 Elf Lithium EP2 Total Multis EP2 Shell Calithia EP2T Texaco Multifak EP2 BP LS EP2 Silkolene G62 Eurol Universalfett EP2 Axel Christiernsson Lithac 162 EP Castrol Spheerol EPL2 Shell Alvania Grease EP(LF)2 Mobil Mobilux EP2 Fina Marson EPL2 SKF LGEP2 GB Lithium EP2 Esso Beacon EP2. LMX Grease

Spindle Bearing Journal:

Optimol Optimoly White Paste 'T' (*available as detailed below*)

1 Kg Tub - Meritor CVA Part Number99538008

100 gm Tube - Meritor CVA Part umber.99538009

Hub & Bearing Grease Fill Volumes

TP Hub

Hub Cavity	500 - 600gm
Inner Bearing	35 - 40gm
Outer Bearing	35 - 40gm
Hub Cap	Nil



CAUTION: Only use the grease supplied with replacement components/kits, or that specified. Under no circumstance should any other type of grease be used.

Service Tools

10

- pg. 45 MST 3103 - Bearing Driver
- pg. 45 MST 3106 - Oil Seal Driver
- pg. 45 MST 3211 - Wheel Bolt Removal Tool
- pg. 45 Oil Seal Driver (Stemco)

10 Service Tools

MST 3103 - Bearing Driver

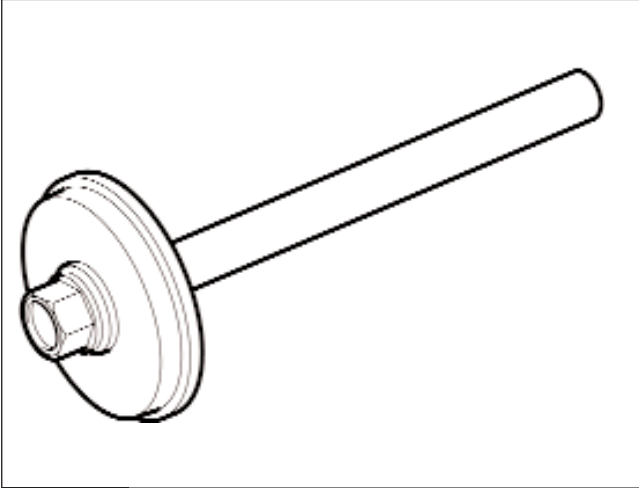

Fig. 10.1

MST 3106 - Oil Seal Driver (ABS Ring installation)

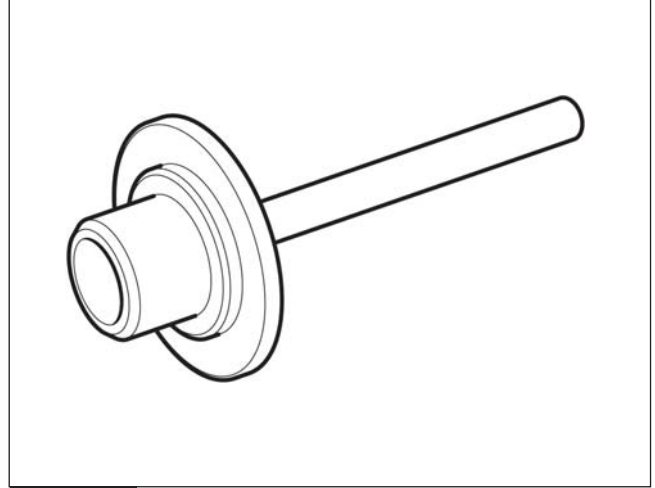

Fig. 10.3

MST 3211 - Wheel Bolt Removal Tool

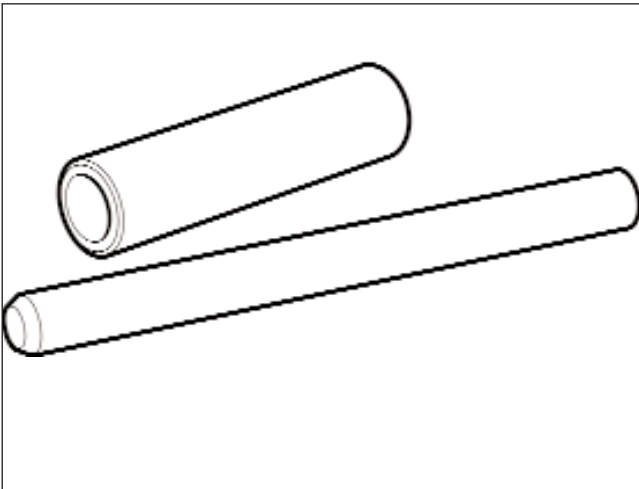

Fig. 10.2

Oil Seal Driver (Stemco Part No. 015525239)

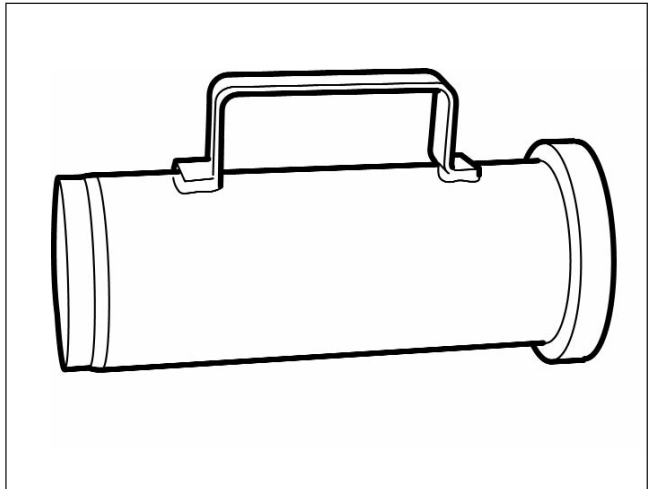

Fig. 10.4

FOR FURTHER INFORMATION CONTACT

Meritor HVS Australia Ltd.
70-76 Berkshire Road
Sunshine North
Victoria 3020
Australia
Tel +61 (0) 3 9300 5208

Meritor Commercial Vehicle Aftermarket
50 Calarco drive
Derrimut
Victoria 3030
Australia
Tel +61 (0) 3 8353 6000

Meritor Inc.
Grange Road,
Cwmbran Torfaen
NP44 3XU - UK
Tel +44 (0)1633 834 040

Meritor Commercial Vehicle Aftermarket AG
Neugutstrasse 89
8600 Dubendorf
Switzerland
Tel +41 44 824 8200



Meritor Heavy Vehicle Systems, LLC
2135 West Maple Road
Troy, Michigan 48084 USA

For more information,
call OnTrac at 866-668-7221
or visit MERITOR.COM.

Descriptions and specifications were in effect at the time of this publication and are subject to change without notice or liability. Meritor reserve the right to make design improvements, change or discontinue parts at any time.