



January 8, 2020

Dear Cottrell Equipment Owner:

Please find enclosed Service Bulletin #SB026 which contains instructions for the reinforcement of the rear grab handle rails over the tandem of the trailer.

Our records indicate that you are the current owner of a Cottrell unit (or multiple units) that may be affected by SB026. The serial number(s) of your trailer(s) are indicated on the enclosed sheet. If you no longer own the trailer(s) identified on the enclosed sheet, please email the new owner information to the following email address:

Warranty@CottrellTrailers.com

Please refer to the enclosed Service Bulletin #SB026 with attached drawing and perform the reinforcement as instructed. Once you have identified your unit/units needing the grab handle reinforcement, please call or email Cottrell, as follows, to request the reinforcement kit, which we will send to you at no charge.

Austin Peal

800-827-0132 Ext 313

Apeal@CottrellTrailers.com

The Cottrell Service Center or any Authorized Cottrell Warranty Repair Facility may perform the reinforcement for you. You can access a list of these repair facilities at www.cottrelltrailers.com under "Find a Dealer."

Cottrell will reimburse labor at a maximum of 1.5 hours per unit for the work associated with this Service Bulletin #SB026. Requests for reimbursement can be submitted with receipt to the above email address or handled directly through the repair facility under normal warranty procedures.

Please perform this reinforcement as soon as possible following the instructions provided. This Service Bulletin #SB026 shall remain open for one (1) calendar year. Should you have any questions concerning this bulletin, please contact Cottrell.

Please be aware during pre-trip, in-transit and post-trip inspections, you should always check grab handles, handrails, and fasteners for proper condition and integrity, just as you would any other part of the equipment.

Sincerely,

Austin Peal / Warranty Coordinator

Apeal@CottrellTrailers.com

800-827-0132 Ext. 313



January 8, 2020

Service Bulletin #SB026

Subject: Rear Grab Handle Reinforcement over Tandem of Trailer

Models Affected: Units listed in enclosed document

Instructions:

1. Identify units needing reinforcement kits per enclosed document with listed VIN's
2. Contact Cottrell with the VIN to have reinforcement kit shipped to a Cottrell Authorized Service facility or directly to you at no charge to you.
3. Schedule the unit for repairs at the Cottrell Service Center or any Cottrell Authorized Service facility.
4. Install rear reinforcement grab handle kit per attached drawing.

Please be aware during pre-trip, in-transit and post-trip inspections, you should always check grab handles, handrails, and fasteners for proper condition and integrity, just as you would any other part of the equipment.

SB026 - Rear Grab Handle Reinforcement

Close-Up

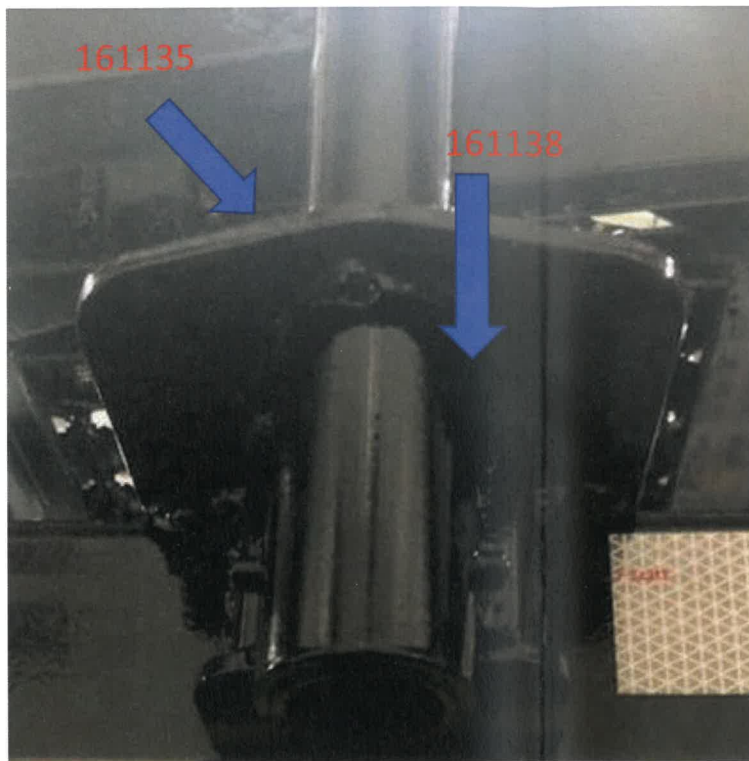

Side Frame View

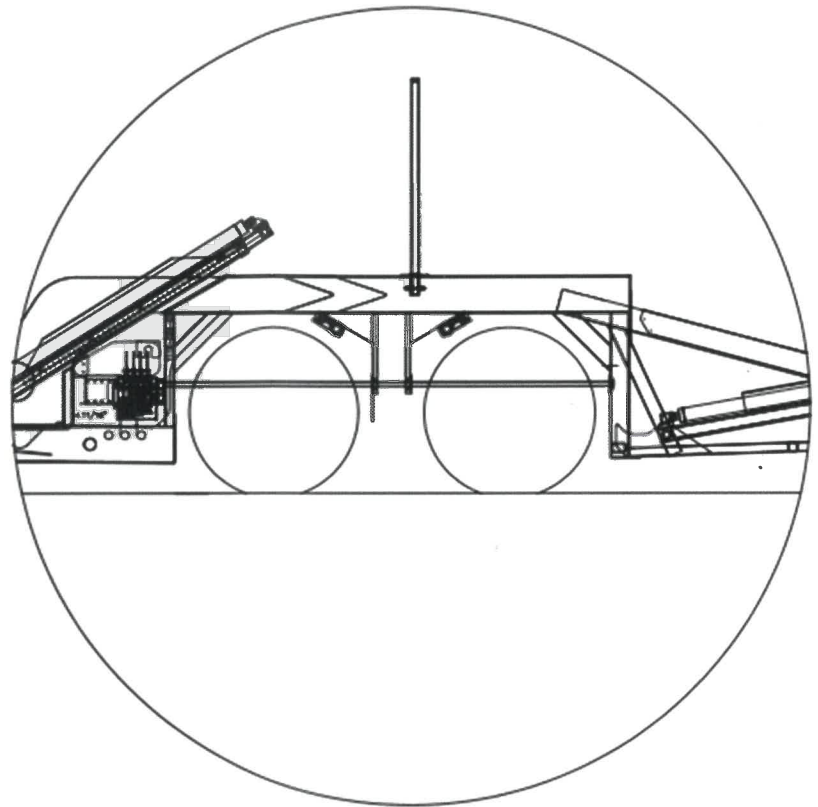

ECO NUMBER	ZONE	REV	REVISION-DESCRIPTION	DATE	BY	CHECKED
C28382						

NOTES:

1. GOUGE OUT AND WELD UP CRACKS.
2. WELD PARTS AS SHOWN.

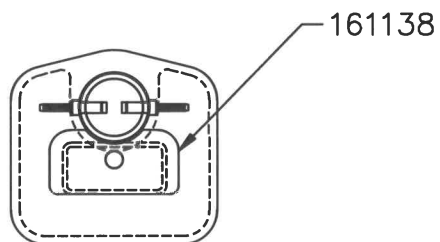
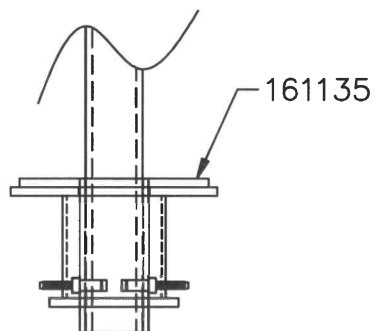
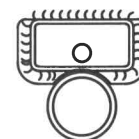
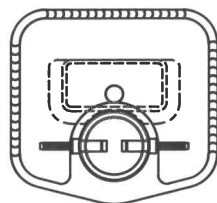

STANDARD TOLERANCES
UNLESS OTHERWISE
NOTED

DEGREES:
±2°
FRACTIONS:
±1/16
DECIMALS:
.X ± .060
.XX ± .030
.XXX ± .010

THE INFORMATION CONTAINED IN THIS
DRAWING IS THE SOLE PROPERTY OF
COTTRELL, INC. ANY REPRODUCTION OR
USE OF THIS INFORMATION WITHOUT
THE WRITTEN PERMISSION OF COTTRELL
INC. IS PROHIBITED.

ORIG BY: DST	PROG. NO. —	MATERIAL —	MATERIAL DESCRIPTION —			
ORIG DATE: 10/14/2019	PROG. BY —	MAKE FROM —	PART YIELD —	SIMILAR TO —	SCALE 1:1	
CHK BY: —	PROG. DATE —	FINISH —	WEIGHT —	DWG. NO. —	SIZE A	
CHK DATE: —	TITLE KIT HAND RAIL REINF	PART NO. 161137		REV IR		

SHEET 1 OF 1