



27th WORLD GAS
CONFERENCE
WASHINGTON DC

JUNE 25-29
2018



TRIENNIUM WORK REPORT JUNE 2018

FLNG Concepts
Facts and Differentiators

PRODUCED BY:
INTERNATIONAL GAS UNION

FUELING THE FUTURE
WGC2018.COM

Contents

1 Executive Summary.....	3
2 Scope of Work and Approach.....	6
3 LNG Outlook and Trends	7
4 LNG FSRUs	10
4.1 Drivers	10
4.2 Relevant LNG FSRU projects	11
4.3 Open Sea vs. Near Shore	11
4.4 Case studies including comparisons	13
4.4.1 FSRU Toscana – open sea FSRU conversion	14
4.4.2 Offshore vs. Onshore Case Study Ain Sohna and Dragon LNG.....	18
4.4.3 Offshore vs. Onshore Case Study Guanabara Bay and Map Ta Phut.....	23
4.4.3 Sungai Udang, Melaka – Nearshore conversion single jetty	28
4.5 Conversion vs. New-built.....	31
5 LNG FPSOs	34
5.1 Drivers	34
5.2 Relevant LNG FPSO projects	35
5.3 Open Sea vs. Near Shore	37
5.4 Case studies LNG FPSO Open Sea	39
5.4.1 Prelude FLNG	39
5.4.2 Petronas FLNG1 (Satu).....	44
5.5 Case studies LNG FPSO Near Shore	47
5.5.1 Caribbean FLNG.....	47
5.5.2 Golar Hilli	50
5.6 Conversion vs. New-built.....	53
6 Conclusions, Challenges and Outlook.....	54
6.1 LNG FSRUs.....	55
6.2 LNG FPSOs.....	57
7 References and Acknowledgements	59
8 Glossary of Terms	60

This publication is produced under the auspices of the International Gas Union (IGU) which holds the copyright. The publication must not be reproduced in whole or in part without the written permission of the IGU. However, irrespective of the above, established journals or periodicals shall be permitted to reproduce this publication, or part of it, abbreviated or edited form, provided that credit is given to IGU. This document contains strictly technical information to be distributed during the 27th World Gas Conference in Washington DC, USA, and has no commercial intent.

1 Executive Summary

Scope of Work and Approach

The scope of the study group “FLNG concepts (LNG FPSO & FSRU), facts and differentiators” was to explore the floating LNG concept’s evolution in the recent years, as to provide a view on the trending facts and driving differentiators for the potential use of this concept, in the LNG industry.

Floating LNG concepts are

- LNG FSRUs: Floating storage and regasification units and
- LNG FPSOs: Floating liquefaction, storage and offloading units.

Commercial and technical aspects provide insights in facts and differentiators for the development of FLNG solutions and their particularities. Criteria are extracted, which make FLNG projects feasible, including success/non-success stories. Specific stand-alone study cases are compiled, but also cases with comparisons of onshore versus floating developments.

LNG Outlook and Trends

According to the current LNG demand forecasts from main analytical agencies, the market will not eliminate its surplus until 2022-23. However, FIDs on new LNG supply are required by the next decade to avoid a tight market in the 2020s, given the typical LNG onshore projects implementation delivery times.

LNG sales contracts are moving towards shorter terms, changing the definition of a long-term contract. Suppliers will need to be flexible in contract terms including length, destination and indexes. This increased flexibility applies to both the producing and receiving facilities for LNG and implicates an impact to development of FLNG concepts.

Niches in the LNG market will continue to play an important role in demand growth: FLNG concepts, and small and mid-scale LNG are added-value solutions for the long run or as a bridge solution awaiting development of larger production/consumption.

LNG FSRUs

FSRUs are proven, reliable, competitive, and flexible solutions that can offer significant advantages over onshore LNG import facilities. The main potential benefits of FSRUs are cost optimization and reduced time-to-market as well as reduction in regulatory and permitting complexity.

FSRUs offer benefits in terms of flexibility via the ability to relocate the facility and can resume production immediately at another location. In addition, FSRUs can provide flexible business models for projects promoters, such as the ability for a time charter instead of upfront CAPEX

This publication is produced under the auspices of the International Gas Union (IGU) which holds the copyright. The publication must not be reproduced in whole or in part without the written permission of the IGU. However, irrespective of the above, established journals or periodicals shall be permitted to reproduce this publication, or part of it, abbreviated or edited form, provided that credit is given to IGU. This document contains strictly technical information to be distributed during the 27th World Gas Conference in Washington DC, USA, and has no commercial intent.

investment. Modularisation and/or combinations of FSRUs with FSUs can provide fit-for-purpose solutions that enable to reach markets in a required time schedule.

FSRUs should be close to the coast, inside a port or a protected area. With respect to near shore versus open sea FSRUs, near shore has many advantages when implemented in a protected and developed port. The open sea solutions, likely to be exposed to harsh metocean conditions, have not been as widely applied so far.



There are issues to address comparing a new built and a converted FSRU. CAPEX and OPEX considerations are important but also flexibility has an impact on the decision-making process. Conversions may take less time and have benefits from a CAPEX perspective, but new-builts can be developed with more design flexibility and longer life span. Differentiators between the two options are project duration, regulations, EPC companies, shipyards, owners, technical challenges, and business opportunities.

LNG FPSOs

LNG FPSOs have been discussed for decades. Facts supporting the installation of an LNG liquefaction facility on a floating structure are non-availability or difficult access to the waterfront, long subsea pipeline distances, and navigational limitations to shore, or the production scale. These factors are triggers for an LNG FPSO project.

LNG FPSOs can be relocated but with significant effort, and most likely require major modifications to adjust to the new gas field composition and conditions. Like FSRUs, LNG FPSOs can provide a fast track schedule e.g. for small/mid-size fields or if a bridge solution is required prior to a larger scale production.

An LNG FPSO facility can be constructed and commissioned in a controlled shipyard environment with higher productivity and often lower labour rates. It therefore can provide





savings versus the construction of a conventional stick-built onshore liquefaction facility. The difference between shipyard construction and commissioning is the fact that it provides higher delivery schedule and cost confidence than onshore construction. Like FSRUs commercial tolling or lease arrangements can be applied to near shore small to mid-scale LNG FPSOs avoiding the initial capital outlay.

The technical concepts and solutions for open sea and near shore LNG FPSOs are different. Open sea LNG FPSOs are preferably utilised to avoid long pipelines, but are without doubt more exposed to metocean conditions, and thus require technically sophisticated mooring and berthing solutions.

FSRUs and LNG FPSOs conversions versus new-builts

Both for LNG FSRUs and LNG FPSOs, the discussion on facts and differentiators between conversion and new built alternatives is one of the first and most important steps, which influences the choice. A good understanding of the facts and differentiators of the alternatives is a prerequisite to take the right decision. The assessment shall be based on cost information, schedule requirements, project execution insights, and technical compromises.

Conclusions

Over the last decades the LNG industry has built up experience with floating LNG concepts generating many success stories but also examples with less positive feedback. There is no such thing as a typical floating LNG project. Many projects are basically prototypes and one-off developments.

The main drivers/challenges for developing these projects are location, countries' energy policies, regulations, environmental impacts, business model flexibility, financing, overall LNG market trends maybe more than the technological aspects, as LNG vaporisation processes for FSRUs and liquefaction processes for LNG FPSOs are well-known and applied throughout the LNG industry. As for any LNG development, the potential optimization in terms of costs and implementation schedule are part of the key enablers for the FLNG developments.

The regasification floating solutions (FSRU) have experienced a high momentum in the recent years because of the flexibility they provide for having shorter time-to-market solutions especially for newcomers to the LNG or for seasonal demand issues. On the other hand, the LNG FPSOs have somehow experienced a lesser success in the last years, following the trend in the LNG industry, in which only a few liquefaction FIDs have been taken in a short-term scenario with depressed gas prices and oversupply.

FSRUs keep on growing fast. With recovered demand growth and higher price signals LNG FPSOs can gain momentum for developing small-to-mid size stranded gas resources.

2 Scope of Work and Approach

The scope of the study group “FLNG concepts (LNG FPSO & FSRU), facts and differentiators” was to explore the floating LNG concept’s evolution in the recent years, as to provide a view on the trending facts and driving differentiators for the potential use of this concept, in the LNG industry.

Commercial (contracting, business drivers, financial viability, and players) and technical aspects provide insights in facts and differentiators for the development of FLNG solutions and their particularities. Criteria are extracted, which make FLNG projects feasible, including success/non-success stories. Specific stand-alone study cases are compiled, but also cases with comparisons of onshore versus floating developments.

The report is split into two main floating LNG concepts’ sections: Floating concepts for LNG production facilities (LNG FPSO), and for regasification facilities (FSRU), which were evaluated via selected representative case studies. For both sections, the selected study cases intend to be representative of the most relevant FLNG approaches and concepts. The report covers comparisons between selected FLNG cases and onshore LNG cases. (both for LNG FPSO and FSRU)

The following subdivisions have been applied throughout the report:

- Liquefaction (LNG FPSO) concepts are split into two main types: (i) LNG FPSOs in open sea conditions and (ii) Near shore LNG producing projects (referred to floating production moored to a jetty). The same applies for the regasification (FSRU) concepts, which are also divided between open sea and near shore conditions
- Within each of the LNG FPSOs and FSRU sections, the report covers both new-builts and conversions of existing LNG carriers as differentiated cases.

3 LNG Outlook and Trends

LNG business is evolving as market structure changes: near-term oversupply is the most pressing challenge affecting the market; new supplies are more flexible and large volumes are not committed to end users.

In 2016 world's total liquefaction capacity was about 340 MTPA¹, growing at a similar rate as in 2015 adding 10%¹ of capacity. These additions will increase as 114.6 MTPA¹ of capacity that was under construction in Jan. 2017. This global growth in capacity will outpace demand in the next decade. US and Australia will be the main contributors to new capacity. Australia will have the largest capacity in the world by 2018 reaching 85 MTPA from 43.7 MTPA¹ in 2016. In US, 57.6 MTPA¹ is under construction. Meanwhile, the challenge for this supply is finding a market and competing with the contracted, unsold volumes already available.

Potential for gas/LNG demand in Asia is still huge. However, many uncertainties impact the demand forecasts such as: competition of fuels in power generation (mostly coal), path of renewables development, internal gas market reforms, and climate policy goals. Traditional LNG consumers, Japan, South Korea and Taiwan, provide flat demand in the coming years. In 2016 with relatively low prices Japan and South Korea imported less volume than in the past 4 years due to slower economic growth and lower priced competing fuels. As their contracts expire, in longer term, demand gap will widen. The main LNG demand growth is expected to come from China, India and emerging Asian countries. This demand potential is the biggest driver of glut resolution.

During last years, Europe became a residual market for LNG that was not consumed in Asia. European LNG imports are expected to grow in the coming years, because of energy policy changes in several countries, increasing role of renewables, withdrawal of nuclear and declining domestic production. Middle East and North Africa region has become one of the LNG fastest growing demand centres. Fundamentally, the push to import LNG has been driven by domestic gas demand growth, steep decline in LNG prices and the availability of FSRUs providing with more flexibility for new demand.

The growing awareness of emerging supply-demand imbalance inspires less confidence to sponsors of new LNG capacity. Given current LNG demand forecasts from main analytical agencies, the market will not eliminate its surplus until 2022-23. However, with increasing market perspectives, FIDs on new LNG supply are required by the next decade to avoid a tight market in 2020s, given 5-year delivery times.

¹ IGU Report 2017

This publication is produced under the auspices of the International Gas Union (IGU) which holds the copyright. The publication must not be reproduced in whole or in part without the written permission of the IGU. However, irrespective of the above, established journals or periodicals shall be permitted to reproduce this publication, or part of it, abbreviated or edited form, provided that credit is given to IGU. This document contains strictly technical information to be distributed during the 27th World Gas Conference in Washington DC, USA, and has no commercial intent.

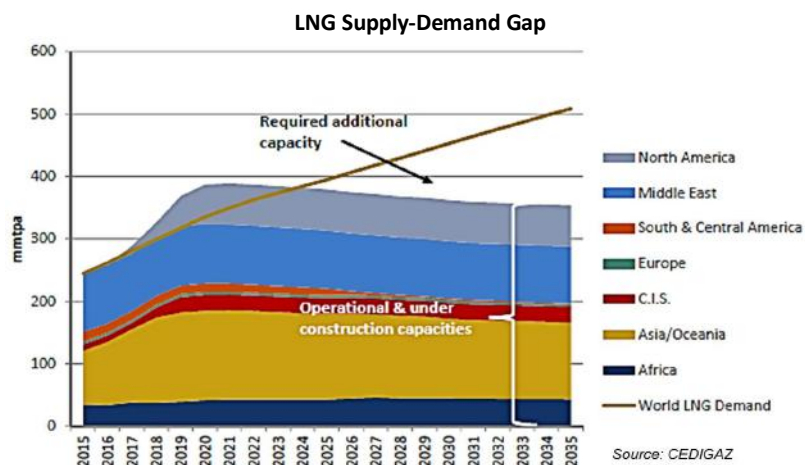

Note: ¹ Source: IGU Report 2017.

LNG prices have been falling since 2014 due to weakening demand from the top importing Pacific basin countries, abundance of supply from new plants and steep decline in oil prices. During the winter 2016-2017 Asian LNG spot price rose as cold weather increased demand, but contract prices paid by key Asian countries have still been less than half the price of 2014. Additional supply will keep downward pressure on prices in Asia over the next several years until the supply-demand rebalance.

Monthly Average Regional Gas Prices, 2010 - January 2017

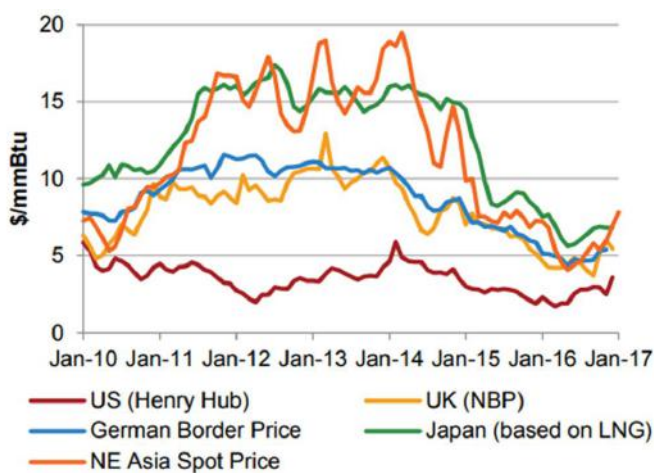

Source: IGU 2017 Report

This publication is produced under the auspices of the International Gas Union (IGU) which holds the copyright. The publication must not be reproduced in whole or in part without the written permission of the IGU. However, irrespective of the above, established journals or periodicals shall be permitted to reproduce this publication, or part of it, abbreviated or edited form, provided that credit is given to IGU. This document contains strictly technical information to be distributed during the 27th World Gas Conference in Washington DC, USA, and has no commercial intent.



As of 2016 the bulk of global LNG was under long-term contract, out of this, over 10% (according to different estimates) is contracted as portfolio sales for re-marketing. More recently signed contracts are moving towards shorter terms, 11-15-year contracts are rising sharply, fixing the new definition of long-term contract. As current contracts expire, an increasing percentage of volume will be priced against different indexations. Suppliers will need to be flexible in contract terms including length and destination. Big gas companies and utilities have evolved towards portfolio business models, optimizing their purchases together with regasification, downstream positions and fleet. Derivative instruments are increasing like swaps or futures to exploit arbitrage opportunities, also there are more trading companies entering the market. Buyers are going for a mix of different types of pricing formulas in order to cover various possibilities for the evolution of the gas price and oil price.

New niches of LNG market will play an important role in demand growth: FSRUs and different forms of small-scale LNG seen as affordable solutions to energy supply issues. Developers may have to sign more contracts because new consumers are generally smaller, requiring smaller financial commitments. FSRUs offer a low cost, fast track and flexible option compared to traditional onshore terminals, giving opportunity to expand the LNG market internationally. An example is the gas to power business being developed by smaller independent power companies who wish to serve developing countries by offering a clean and efficient source of fuel.

On the LNG producing side, LNG FPSOs are also kept in radar of LNG producers, due to many advantages and possibility to produce volumes adapted to concrete market, although the degree of development (new projects) on this production side has been well below the evolution from the FSRUs side. While there has been a decline in oil prices and related cuts in O&G budgets, the industry continues to spend significant time and capital on new ideas to reduce costs, improve safety and reduce environmental impacts.

4 LNG FSRUs

4.1 Drivers

The use of natural gas as clean fuel to reduce air pollution and in particular SO_x, NO_x and particulate matters is spread worldwide at locations in all the continents. Natural gas importing countries should also rely on LNG imports in order to have flexibility and security of supply.

LNG regasification terminals are in operation for more than fifty years but floating regasification terminals are relatively new, the first becoming in service in 2005. However nowadays FSRUs are a proven, reliable, competitive, and flexible solution that can offer significant advantages as compared to LNG import facilities onshore.

The main benefits are listed as follows:

- In terms of cost & time.
 - Construction or conversion costs for an FSRU can be as low as a fifth of the cost of an onshore import terminal. As an example, Excelerate Energy, the largest FSRU fleet owner and operator, estimates current construction costs to be over 300 USD million, a fraction of an onshore facility which is often 1 billion USD or more.
 - FSRU conversion can be completed in about one and a half year, versus 3-5 years for an onshore terminal. On the other hand, the average delivery time for an FSRU new-built is in the range of 3 years only.
- Regulatory & permitting issues.
 - Get production up and running faster by reducing the time spent on permitting as compared to building onshore processing facilities.
 - Minimize environmental impact as a result of open sea or near shore location.
- In terms of flexibility.
 - Ability to move the units at the end of a project to a new location, and start regasification immediately, and cutting costs significantly in the long term.
 - By moving the unit as required it is an easy response to global changes in gas demand.
 - Ability to increase supply during seasonal peak demand across different regions.
 - Flexibility also means that different technical solutions can be considered depending on the specific project. Modularization can be a way to overcome issues related to location or other challenges by means of deployment of FSU and regasification onshore, FRU plus FSUs to increase the storage capacity, etc.

- Most of the cases have specific business models in which the owner of the FSRU is chartering the unit to the terminal owner.
- Increase viability. Use smaller-sized units to exploit hard-to-reach markets, for example, South-East Asia, and ensure untapped resources are left to a minimum.

4.2 Relevant LNG FSRU projects

The below table includes the distribution of FSRUs by region that are up and running at the moment and other FSRUs that are presently involved in LNG transportation (not committed).

Region	New-builts	Max. Regasification (MTPA)	Conversions	Max. Regasification (MTPA)
Africa	2	8.81	-	-
America	4	21.27	1	3.97
Asia	3	13.97	1	3.89
Europe	3	12.87	1	4.21
Middle East	5	29.69	1	3.97
Not committed	5	24.29	1	2.06
Total	22	110.89	5	18.10

The following list includes the most relevant FSRUs and FSUs that are under construction or conversion at the moment.

Location	Developer	Details
Turkey	KOLIN CONSTRUCTIONS	HHI New-built
Kaliningrad	GAZPROM	HHI New-built
Bahrein FSU	TEEKAY	DSME New-built
India (Jafrabad)	SWAN ENERGY/MOL	HHI New-built
Indonesia (Java-1)	CONSORTIUM	SHI New-built
Bangladesh	EXCELERATE	Available FSRU fleet
Chile	HOEGH	HHI New-built

4.3 Open Sea vs. Near Shore

By definition, regasification terminals should be close to the coast or inside a port or protected area. The main reason being that a long gas pipe would be required in case of an offshore terminal.

This publication is produced under the auspices of the International Gas Union (IGU) which holds the copyright. The publication must not be reproduced in whole or in part without the written permission of the IGU. However, irrespective of the above, established journals or periodicals shall be permitted to reproduce this publication, or part of it, abbreviated or edited form, provided that credit is given to IGU. This document contains strictly technical information to be distributed during the 27th World Gas Conference in Washington DC, USA, and has no commercial intent.



In fact, the only open sea terminal, located 12 miles off the coast is the FSRU Toscana. This is a very specific case where local regulatory permits are quite severe to develop onshore or near shore terminals.

Near shore applications have been the common approach of FSRU applications, because there are many advantages when developing the project in a protected area. Some of these advantages are the following:

- Jetty or port facilities might be already in place. Protection for the FSRU and LNG carrier calling the terminal may be already implemented, in case the FSRU is installed inside a port.
- Mooring (or anchoring) of the unit should be more standard and less expensive.
- Proximity to the gas grid and clients will reduce cost of the overall project.
- Benign water and weather conditions will reduce the operational challenges and overall cost.
- Available space onshore in case that additional facilities are required in the future.
- Logistics are easier for related maintenance, including transit of crew or technicians from shore.

As mentioned, the example of the FSRU Toscana is the only case of open sea floating regasification terminal. A complete description of the project is included in the case studies where the main differences between this type of open sea project and a near shore terminal are described.

In the near shore FSRU terminals, two main configurations are normally considered, an FSRU cross jetty, and an FSRU single jetty configuration. There are some pros and cons associated with these two configurations.

FSRU Cross Jetty

Pros:

- Safer and more stable operation (same as LNG Carrier unloading to onshore terminal) installing similar hardware such as loading arms, stable mooring and quick emergency response.
- Large LNG storage buffer capacity
- No limitation of LNG carrier size (regardless of the size of FSRU).
- Potential for business expansion (reloading function, hub terminals, small scale, etc.)

Cons:

- High CAPEX due to double platform, dolphin system and equipment such as loading arms, quick release, piping, emergency system, etc. The jetty itself is more robust.

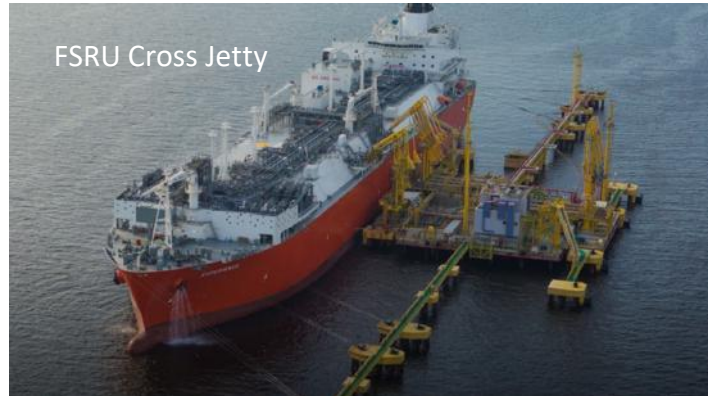

FSRU single jetty (STS LNG Transfer)

Pros:

- Lower CAPEX.
- Prompt installation.

Cons:

- More strict operation limit due to weather/met ocean conditions.
- Risk assessment and HAZOP to be provided for the STS transfer.

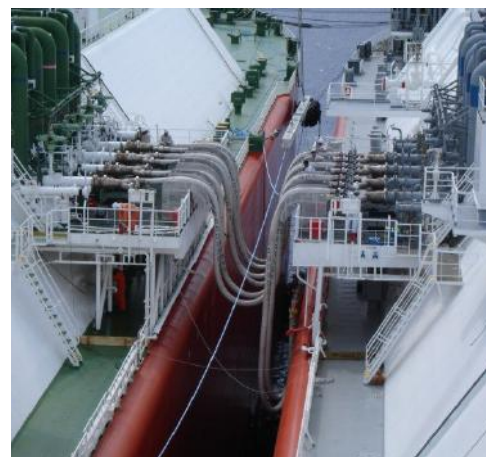

4.4 Case studies including comparisons

The following case studies have been selected for the main reasons described.

- Case study FSRU Toscana.

This publication is produced under the auspices of the International Gas Union (IGU) which holds the copyright. The publication must not be reproduced in whole or in part without the written permission of the IGU. However, irrespective of the above, established journals or periodicals shall be permitted to reproduce this publication, or part of it, abbreviated or edited form, provided that credit is given to IGU. This document contains strictly technical information to be distributed during the 27th World Gas Conference in Washington DC, USA, and has no commercial intent.



This case is a conversion of a relatively new LNG carrier into a very singular open sea project. The selection of this project for the report is based on the technical singularity, and exposed location of the floating asset, and therefore no comparison with an onshore terminal has been considered.

- **Case studies and comparison Ain Sokhna (Hoegh Gallant) FSRU and Dragon LNG Terminal**
The main reasons to select these two projects are as follows. Both cases are showing relatively new facilities with similar regasification capacities but based on two different concepts. Hoegh Gallant is a new-built near shore floating installation while Dragon LNG is an onshore terminal. Transfer of LNG into the Hoegh Gallant is by means of STS which is a quite common procedure nowadays.
- **Case studies and comparison Guanabara Bay FSRU and Map Ta Phut LNG Terminal**
Both cases are showing modern facilities based again on two different concepts, floating and onshore. The reasons to select and compare the terminals are similar as in the above case studies. The main highlighted difference in Guanabara Bay floating installation is a jetty island to transfer LNG cargo into the FSRU and send out natural gas to shore. This jetty island is located near shore but in protected waters inside the Guanabara Bay. Map Ta Phut LNG Terminal is an onshore terminal with quite similar regasification capacity for comparison purposes.
- **Case study Re-gasification Terminal (RGT) Sungai Udang, Melaka**
This terminal has been selected for its singularity taking into consideration that it comprises two LNG carrier conversions of membrane containment system into FSUs, and the regasification facility being installed on the jetty. This means that this is a unique project that has not been compared to an onshore terminal.

4.4.1 FSRU Toscana – open sea FSRU conversion

The FSRU Toscana is a conversion of a Moss type LNG carrier built in 2004 in Hyundai Heavy Industries for Golar LNG.

The FSRU unit finally started-up operations in 2014 as the World's first LNG Regasification Terminal permanently-moored in open sea in its current location 22 km off the coast of Livorno (Italy) at 120 m water depth.

The terminal is completely self-sufficient having the same operational features than a typical onshore regasification terminal in Italy.



FLNG Main Players

The main actors presently involved in the FSRU terminal are as follows.

- Offshore LNG Toscana S.p.A. is the owner of the terminal and has the following shareholders: IREN GROUP (Italian multi utility) and UNIPER.
- Saipem was involved in the conversion as engineering company as EPC contractor.
- The conversion was carried out in Drydock Worlds of Dubai and the fabrication of the regasification modules was in charge of Lamprell yard.
- The terminal is managed by Exmar and Cosulich.

Technological Aspects

The terminal floater is the hull of a Moss type LNG carrier suitably converted and modified, to install regasification modules, loading arms, Wobbe index adjustment, and mooring/anchoring equipment.



This publication is produced under the auspices of the International Gas Union (IGU) which holds the copyright. The publication must not be reproduced in whole or in part without the written permission of the IGU. However, irrespective of the above, established journals or periodicals shall be permitted to reproduce this publication, or part of it, abbreviated or edited form, provided that credit is given to IGU. This document contains strictly technical information to be distributed during the 27th World Gas Conference in Washington DC, USA, and has no commercial intent.



FSRU. Among others a newly built rotating turret was welded to the bow of the FSRU, and acts as single point mooring to allow the unit to weather vane. The aft part of the hull was also modified to install a transversal thruster and the access trunk for personnel. In addition, huge bilge keels have been added in order to stabilize the FSRU. The hull was reinforced forward and at the loading manifold on the starboard side for the installation of the regasification module, and loading arms.

Once finished the hull measures 310 m in length and 50 in beam and holds 4 spherical Moss-type tanks to contain the LNG with a total capacity of 137,500 m³ up to a maximum pressure of 0.25 bar gauge. New high capacity low pressure submerged retractable transfer LNG pumps were installed in each tank.

Inside the hull, the propulsion system was completely removed and 2 x 10 MW new steam turbo generators were installed in the engine room in addition to the 2 x 3.5 MW existing ones.

The LNG regasification module built offsite in Lamprell yard was installed with single 2,000 tonnes lift on the forward part of the hull. The maximum capacity of the regasification module is 450 tons of LNG per hour (equivalent to approximately 3.9 MTPA). The system consists of three intermediate fluid vaporizers (IFV) manufactured by Kobe steel, a BOG compressor, a BOG recondenser and a high-pressure pump. The recondenser is a key equipment item for BOG management.

A smaller module for nitrogen generation (Wobbe Index Correction and inerting purposes) was built offsite and installed in the aft part of the hull. The purpose of the Wobbe unit is to deliver on-spec. sales gas (47.3 - 52.3 MJ/Sm³ is required by Italian distribution network), and to be used as fiscal quality control and measurement module.

LNG loading arms (traditional onshore jetty-type) have been provided by FMC. The designer has considered the largest ever motion capability for offshore use in STS transfer up to 2.5 m wave height. The total transfer capacity of the arms is 12,000 m³/h considering LNG carriers from 65,000 to 155,000 m³.

The DCS, ESD, F&G systems were completely re-designed.

The following rules and certification are applied to the FSRU Toscana.

- RINA Class Rules (for LNG Floating Units)
- Italian flag
- ISO 9001 (quality), ISO 14001 (environment), OHSAS 18001 (health and safety of workers), SA 8000 (Social Responsibility) all granted by Bureau Veritas.
- The terminal is subject also to Seveso directive regulation.

In addition to the certifications mentioned above, very low environmental limits have been considered in the design of the unit such as:

- Maximum delta temperature of sea water used for regasification is -4.6 K.
- Maximum free chlorine in sea water of 0.05 mg/l (drinking water for human consumption is 0.2 mg/l).

- No venting of natural gas except for emergency purposes.
- NOx emissions limit of 150 mg/ Nm³, and maximum limit of NOx emissions of 100 tons/year.

Business Aspects and Development Drivers

The terminal is implemented following some business aspects and development drivers.

- FSRU Toscana is based on an equity business model with OLT as owner and Exmar Ship management and Fratelli Cosulich Spa as operators.
- Unicredit financed the acquisition of the Golar Frost in 2008. Another 240 million Euro were provided by European Investment Bank in 2011 for the conversion.
- The driver for the development has been to establish an energy peak saving solution.
- The unit is one of the most expensive FSRU built or converted. The acquisition price of the unit is understood to be 231 million USD. In addition, because of the sophisticated equipment installed onboard and the duration of the works the estimated cost for the conversion is 500 million USD. As reported in Saipem web the contract for Engineering, Procurement, Construction and Installation was 390 million Euro.
- Approximately six years were required for the conversion from the acquisition of the LNG carrier to the first regasification operation which took place in Livorno in 2014 due to the unique project constraints and sophistication.
- The redeployment of the unit in another location is unlikely to happen as there will be a need to put in place the necessary subsea infrastructure such as gas pipeline.
- In conclusion, FSRU Toscana is a very specific offshore LNG project. Some facts of this import terminal make this facility unique in the world:
 - Conversion of a newly built ship.
 - Location offshore.
 - Transfer side by side with loading arms with a single point mooring.
 - Intermediate fluid vaporizers (IFV), BOG recondenser and Wobbe index facilities.

References²

2

SIGTTO Terminal report edited 21 Sep 2015

OLT Offshore LNG Toscana S.p.A.

<http://www.oltoffshore.it/en/Saipem>

<http://www.lngworldnews.com/italy-eib-grants-eur-240-million-loan-for-livorno-lng/>

http://www.golarlng.com/index.php?name=seksjon/Stock_Exchange_Releases/Press_Releases.html&pressrelease=1197175.html

<http://www.drydocks.gov.ae/en/default.aspx>

<http://www.shipspotting.com/gallery/photo.php?lid=1762434>

<http://www.cosulich.it/>

<http://www.maltatoday.com.mt/news/national/28668/the-beauty-and-the-beast-20130727#.V8BHv1t97cs>

<http://www.ecos-lng.com/>

http://www.saipem.com/SAIPEM_en_IT/scheda/Livorno+FSRU.page?

This publication is produced under the auspices of the International Gas Union (IGU) which holds the copyright. The publication must not be reproduced in whole or in part without the written permission of the IGU. However, irrespective of the above, established journals or periodicals shall be permitted to reproduce this publication, or part of it, abbreviated or edited form, provided that credit is given to IGU. This document contains strictly technical information to be distributed during the 27th World Gas Conference in Washington DC, USA, and has no commercial intent.

4.4.2 Offshore vs. Onshore Case Study Ain Sohna and Dragon LNG

4.4.2.1 Ain Sokhna (Hoegh Gallant) – nearshore single jetty new-built

Ain Sokhna LNG import terminal is an FSRU named Hoegh Gallant, deployed near shore at a single jetty. The FSRU Hoegh Gallant is located in Ain El Sokhna port on the west coast of the Gulf of Suez in the red sea (Egypt), approximately 30 nautical miles south of to the Suez Canal.

The owner of the FSRU is Hoegh LNG. Hoegh LNG will operate and remain responsible of the specific installation of FSRU including the import manifold and offloading natural gas on the jetty structure.

A risk assessment 'HAZOP' (Hazard and Operability study) was carried out well before start of commercial operations in order to ensure safe marine operations at Ain El Sokhna port, due to potential risks of domino effects of ammonia activities in other side of the jetty.



FLNG Main Players

The main player of this business is EGAS (Egyptian Natural Gas Holding Co.) which is a state company 100% controlled by Egyptian government. EGAS is importing LNG cargos through the FSRU Hoegh Gallant for storage and regasification to natural gas, and final send out to the main pipeline grid.

The contract of chartering for the LNG FSRU between EGAS and Hoegh LNG is for a period of five years. The first commercial operation started the second quarter of 2015.

Technological Aspects

The main technical characteristics of Ain Sokhna LNG import terminal are as follows:

- The FSRU 'Hoegh Gallant LNG receiving terminal located at Ain Sokhna port is a new-built by Hyundai Heavy Industries built in Ulsan shipyard, South Korea.
- The FSRU cargo containment system is based on four (4) LNG tanks of membrane reinforcement type, with total capacity tanks of 170,051 m³ at 100%.
- The regasification capacity is 3.8 MTPA and comprises of three equally sized regasification trains. The regasification process is based on an open loop concept with propane/sea water as heating medium. Natural gas send-out pressure and temperature are 65-103 barg and +5°C respectively.
- The FSRU is moored to a single jetty at port side.
- Ship to ship (STS) LNG transfer method is used to load the FSRU by means 6 LNG transfer hoses (4 liquid and 2 vapor) at starboard side.
- Eighteen quick release hooks (QRH) of 135 ton each are installed (double hook x 8 sets, single hook x 2 sets) for STS transfer.
- The FSRU is equipped to manage a maximum 8 ton/h of boil of gas.
- Construction schedule. Contract date: February 2012 and commissioning: February 2015

References³

³
DP WORLD Sokhna and EGAS
Hyundai Heavy Industries shipyard
Hoegh LNG and HYPROC SC

4.4.2.2 Dragon LNG Terminal

Dragon LNG Terminal import, storage and regasification terminal is situated on the shores of the Milford haven Waterway in Pembrokeshire, South West Wales; alongside the only Coastal national park in the UK.

Receiving its first LNG cargo on 14th July 2009 (commissioning stage) and commercial operation on 2nd October 2009, Dragon's terminal consists of a jetty, storage tanks and regasification facilities, combined with gas export capabilities for 365 days per year, continuous operation and a maximum gas send out rate to the UK's National Transmission System (NTS) of 6.0 MTPA, peak. The start-up capacity of the new terminal provides up to 5% of natural gas demand in the UK.

FLNG Main Players

Dragon LNG Terminal is a standalone business with its own management team. This team draws on the experience of its two shareholders of which PETRONAS is one with 50% equity and capacity stake and the other one is Shell.

It was constructed and put in commercial operation on 2nd October 2009. Whesoe Oil & Gas Ltd (UK), Volker Stevin Construction Europe BV has been responsible for Engineering, Procurement, Construction, and Commissioning (EPCC). And MW Kellogg Ltd has been responsible for construction only.



Technological Aspects

The Dragon LNG terminal has the following technical characteristics.

- Refurbishment and major upgrade of existing Jetty No 1 dedicated to unloading LNG carriers from 71,500 m³ up to 250,000 m³ capacity.
- LNG transfer 'topside' facilities on Jetty No 1 including three LNG unloading arms and one hybrid arm (maximum unloading rate of 12,000 m³/hr, reloading capability of 1,500 m³/hr).

This publication is produced under the auspices of the International Gas Union (IGU) which holds the copyright. The publication must not be reproduced in whole or in part without the written permission of the IGU. However, irrespective of the above, established journals or periodicals shall be permitted to reproduce this publication, or part of it, abbreviated or edited form, provided that credit is given to IGU. This document contains strictly technical information to be distributed during the 27th World Gas Conference in Washington DC, USA, and has no commercial intent.

- Two onshore LNG storage tanks of the full-containment type (2x160,000 m³)
- Boil-off gas handling system, including two BOG compressors and flare.
- Six submerged combustion vaporizers (155 ton/hr each).
- Metering facilities for custody transfer of the high-pressure gas into the NTS pipeline.
- Buildings such as the Main Control Room (MCR), Local Equipment Room (LER), Jetty Monitoring Building (JMB).
- Infrastructure including roads, lighting, security fences and monitoring systems, landscaping, etc.
- Health, safety & environmental (HSE), In addition, the industry is highly regulated and our facility satisfies all relevant UK and European codes and standards.
- It operates within the COMAH Regulations that are enforced jointly by the Health & Safety Executive (HSE) and National Resources Wales. Dragon's LNG terminal also has close links with the UK Security Services to ensure security of the ships, jetty and onshore liquefied natural gas facilities.
- Operation of the jetty complies with the International Maritime Organization's International Ship and Port Facility Security Code (ISPS).
- Facility Process Control and Emergency Shutdown system
- Power distribution system.
- Send out NG pumping facilities and transfer pipeline.
- All associated utility and safety systems.

Business Aspects and Development Drivers

Over 85% of homes in the UK use natural gas and a significant proportion of UK electric power is generated from natural gas as well. The demand for energy and natural gas is increasing at a time when the UK's domestic production from the North Sea is declining. Dragon can supply up to 10% of the UK's energy needs, allowing diversity of supply from 19+ LNG producing countries around the World.

Case Study Conclusion

To serve energy demand in the UK, Dragon LNG terminal was built / constructed since 16th November 2004 and put in commercial operation on 2nd October 2009. It took about 60 months starting from EPC contract awarded

References⁴

4

<http://www.dragonlng.co.uk/>

<http://www.hydrocarbons-technology.com/projects/dragon-lng/>

<http://whessoe.co.uk/experience/lng-tanks/dragon-lng-terminal-uk/>

http://www.maritimejournal.com/news101/industry-news/commissioning_cargo_arrives_at_dragon_lng

http://news.bbc.co.uk/2/hi/uk_news/wales/south_west/7881826.stm

This publication is produced under the auspices of the International Gas Union (IGU) which holds the copyright. The publication must not be reproduced in whole or in part without the written permission of the IGU. However, irrespective of the above, established journals or periodicals shall be permitted to reproduce this publication, or part of it, abbreviated or edited form, provided that credit is given to IGU. This document contains strictly technical information to be distributed during the 27th World Gas Conference in Washington DC, USA, and has no commercial intent.

4.4.2.3 Case Studies Comparison

	Sokhna Hoegh Gallant	Dragon LNG terminal
DRIVERS	Charter FSRU for five year contract in order to satisfy the growing domestic demand of naturel gas in Egypt	Long term security of natural gas supply considering the estimation on rising demand
BUSINESS MODEL	EGAS pays the cost of hire for FSRU to Hoegh LNG. EGAS pays LNG cargos to several suppliers of LNG.	PETRONAS and Shell pay a tariff to DRAGON LNG TERMINAL
FLNG PLAYERS	EGAS 100% (Egyptian Naturel Gas Holding Co.)	PETRONAS 50% and SHELL 50%
REGASIFICATION CAPACITY (MTPA)	3.8 MTPA at 46-100 barg	NOMINAL 4.4 MTPA, PEAK 6.0 MTPA
STORAGE CAPACITY	4 LNG tanks with capacity of LNG tanks at normal filing level 167,500.241m ³ (98.5% capacity)	2x160,000 m ³ (Net capacity, from low level alarm to high level alarm)
EPC	Hyundai Heavy Industries (HHI) Korea, Wartsila Oil Gas Norway, Wartsila-Hyundai/Converteam, Gas Technique Transport (GTT) French	Whesoe Oil & Gas Ltd (UK), Volker Stevin Construction Europe BV, MW Kellogg Ltd
CONSTRUCTION PERIOD	36 Months	60 Months
CERTIFICATION	DNV Classification	NFPA59A and EN1473
HSE	Certified to ISM, ISO9001, ISO14001, OHSAS18001 standards and ISPS Code	ISO 9001, 14001, OHSAS 18001, COMAH Regulations, ISPS CODE
LOCATION	Near shore at single jetty	ONSHORE TERMINAL
LNG TRANSFER	STS LNG Transfer by hoses at FSRU	LOADING ARMS
GAS OFFLOADING	High pressure of naturel gas send-out : 65 bar at 5°C LNG inlet pressure and T°: 5bar and -160°C Regasification pumps retractable 4x550 m ³ /hr Regasification mode: Open loop with propane/sea water	HIGH PRESSURE LNG PUMP >>> LNG VAPORIZER (SUBMERGED COMBUSTION VAPORZER, SCV) >>> GAS PIPELINE

4.4.3 Offshore vs. Onshore Case Study Guanabara Bay and Map Ta Phut

4.4.3.1 Guanabara Bay FSRU – Nearshore cross jetty new-built

Located in Guanabara Bay the FSRU receive, store, regasify LNG, and deliver the natural gas by pipeline into the Brazilian gas grid. The terminal is based on the concept of a LNG carrier with onboard regasification facilities moored in a near shore jetty and the case study describes the terminal during the period the Experience ship was operated as FSRU.



FLNG Main Players

Petrobras leases the FSRU to Excelerate, the owner of the ship, while Exmar Ship Management acts as ship manager. The FSRU was built in DSME (South Korea) which has been responsible for the engineering, procurement, construction and commissioning of the unit.

Technological Aspects

- The type of LNG containment system used is of the Gaz Transport NO96 (developed by Gaz Transport and Technigaz - GTT), the total storage capacity being 173.400 m³. DSME has developed the sealed concept for this technology which allows having a pressure of 0.7 bar gauge as maximum relief valve setting (MARVS).
- Shell and Tube LNG vaporizers of Kopetz and high-pressure pumps of Nikkiso are installed on board of the ship to provide a maximum regasification capacity of 6.3 MTPA.
- As the FSRU terminal is moored alongside an island type offshore jetty structure in the middle of the bay, additional mooring equipment and equipment for loading LNG and offloading gas has been provided on board the FSRU or on the jetty.
- Two 12' high pressure manifolds on board of the FSRU and one high pressure discharging arm on the jetty are provided. A subsea high-pressure piping to shore is installed connecting the jetty to the main land.

This publication is produced under the auspices of the International Gas Union (IGU) which holds the copyright. The publication must not be reproduced in whole or in part without the written permission of the IGU. However, irrespective of the above, established journals or periodicals shall be permitted to reproduce this publication, or part of it, abbreviated or edited form, provided that credit is given to IGU. This document contains strictly technical information to be distributed during the 27th World Gas Conference in Washington DC, USA, and has no commercial intent.

- The transfer of the LNG from the LNG carrier to the FSRU is made by means of standard loading arms on both sides of the jetty. The other part of the jetty is able to accommodate LNG carriers from 70,000 to 210,000 m³.
- With regards to certification, the FSRU is certified by Bureau Veritas under class rules for steel ships and flag in Marshall Island. In addition, International Maritime Organization rules have been applied to the unit such as SOLAS, MARPOL and IGC Code focus on Safety and Environmental issues. Exmar Ship Management is also certified by ISO 9001, 14001, 29001 and OHSAS 18001 standards.

Business Aspects and Development Drivers

Petrobras contracted Excelerate Energy under a 15-year time charter party in order to provide floating storage capacity and regasification. The driver of the development was to keep up with the projected import growing demand mainly for power plants.

Although there are no details as such available for this specific project, the cost of design, construction and commissioning of an FSRU of similar capacity in South Korea may be in the range of 270 to 315 million USD.

In 2012 Excelerate signed the contract for the construction of the FSRU at DSME. The commissioning was performed in April 2014 in South Korea and the first operation in Guanabara Bay started on the 15th of May 2014 as the World's largest LNG Floating Regasification Terminal.

Being the unit a floating concept, the redeployment of the unit in another similar location is possible and has happened after just two years of operation when the FSRU was moved to Pecem terminal.

Case Study Conclusion

The Experience is the largest FSRU facility worldwide and still supplies a significant amount of natural gas to Brazil from Pecem terminal. Anyhow, the gas demand in the country has not achieved the foreseen expectations.

References⁵

-
- 5
- <http://excelerateenergy.com/project/guanabara-bay-lng-import-terminal/>
 - <http://www.petrobras.com.br/en/our-activities/main-operations/terminals-and-pipelines/guanabara-bay-regasification-terminal-lng.htm>
 - <http://excelerateenergy.com/fleet/>
 - <http://www.exmar.be/en/all-exmar-fleets>
 - <http://www.exmarshipmanagement.be/public/page.asp?id=38>
 - http://www.meti.go.jp/medi_lib/report/2014fy/E003815.pdf
 - <http://nationwideradiojm.com/pdf/FinalRport.pdf>
 - <http://splash247.com/excelerate-energy-seals-10-year-sale-leaseback-fsru/>

This publication is produced under the auspices of the International Gas Union (IGU) which holds the copyright. The publication must not be reproduced in whole or in part without the written permission of the IGU. However, irrespective of the above, established journals or periodicals shall be permitted to reproduce this publication, or part of it, abbreviated or edited form, provided that credit is given to IGU. This document contains strictly technical information to be distributed during the 27th World Gas Conference in Washington DC, USA, and has no commercial intent.

4.4.3.2 Map Ta Phut LNG receiving Terminal

According to the estimation on rising demand in commercial utilization of natural gas as well as the continuously rising oil price during 2004-2005, the Thai cabinet had a resolution on May 17, 2005 upon the proposed resolution of the National Energy Policy Board (dated December 23rd, 2004) to have PTT Plc develop LNG importing plan. The objectives of the plan is to prepare the readiness and have the clarity for fuel supply alternatives in order to ensure national security on long term natural gas supply.

PTT Plc forms a new business venture, named PTTLNG, to execute the jetty development and LNG receiving terminal project with its key mission to receive, store, and regasify LNG. The Terminal is located at Map Ta Phut Industrial Estate in Rayong province and its construction started in 2007. Map Ta Phut LNG Terminal started commercial operation on 6 September 2011.



FLNG Main Players

The sole owner of the import terminal is PTT LNG as a wholly owned subsidiary of PTT - Thailand national oil & gas company.

On the other hand, GS Engineering & Construction, Korea Gas Corporation (KOGAS), Hanyang Corporation and Daewoo Engineering company participated in the project as EPC. Additionally, Fluor Daniel was acting as project management consultant (PMC) during the construction and commissioning.

Technological Aspects

The "Map Ta Phut LNG receiving terminal" has a total regasification capacity of 5.0 MTPA with the following technical characteristics.

- Jetty: unloading LNG carriers from 125,000 m³ up to 267,000 m³ capacity.
- LNG transfer topside facilities on Jetty No 1 including two (2) LNG unloading arms, one (1) hybrid arm and one (1) vapor return arm (maximum unloading rate of 15,000 m³/hr).
- Two onshore LNG storage tanks of the full-containment type (Net capacity 160,000 m³ each)

This publication is produced under the auspices of the International Gas Union (IGU) which holds the copyright. The publication must not be reproduced in whole or in part without the written permission of the IGU. However, irrespective of the above, established journals or periodicals shall be permitted to reproduce this publication, or part of it, abbreviated or edited form, provided that credit is given to IGU. This document contains strictly technical information to be distributed during the 27th World Gas Conference in Washington DC, USA, and has no commercial intent.

- Boil-off gas handling system, including two (2) BOG compressors and flare system.
- Other equipment comprises one (1) BOG recondenser, five (5) high pressure pump, capacity: 375 m3/h each, six open rack vaporizers (ORV) with a capacity of 165 ton/hr each.
- From the point of view of certification, the terminal has been built in accordance to NFPA59A: Standard for the Production, Storage and Handling of LNG, EN1473: Standard for Onshore Installation and Equipment Design for LNG standards and follows the SIGTTO (Society of International Gas Tanker and Terminal Operators) Operating Standard and Best Practices in Gas Tanker and Terminal Operation.
- In addition, regarding HSE, the terminal currently holds Quality Management System (ISO 9001:2008), Occupational Health and Safety Management System BS OHSAS 18001:2007, TIS 18001:2554, Environmental Management System (ISO 14001:2004) and Integrated Management System (IMS) certification.

Business Aspects and Development Drivers

The main driver for the development of the terminal was the objective to increase gas imports and secure long-term supply of natural gas according to the estimation on rising demand in commercial utilization of natural gas as well as the continuously rising oil price during 2004-2005.

Case Study Conclusion

Map Ta Phut LNG receiving Terminal is a standard onshore regasification terminal which provided in 2015 up to 11% of natural gas demand in the Thailand. It was built / constructed since 2008 and put in commercial operation on 6th September 2011. It took about 43 months starting from EPC contract awarded.

References⁶

⁶

www.pttlng.com
<http://ptt.listedcompany.com/misc/PRESN/20120106-PTT-analystMeetingLNG-01.pdf>
<http://abarrellfull.wikidot.com/map-ta-phut-thailand-lng-terminal>
http://www.dmf.go.th/publication/Gas%20Plan%20_Final_Publish.pdf

This publication is produced under the auspices of the International Gas Union (IGU) which holds the copyright. The publication must not be reproduced in whole or in part without the written permission of the IGU. However, irrespective of the above, established journals or periodicals shall be permitted to reproduce this publication, or part of it, abbreviated or edited form, provided that credit is given to IGU. This document contains strictly technical information to be distributed during the 27th World Gas Conference in Washington DC, USA, and has no commercial intent.

4.4.3.3 Case Studies Comparison

	FSRU "Experience" Guanabara Bay	Map Ta Phut LNG receiving terminal
DRIVERS	Flexible and fast track solution to cope with expected increased gas demand	Long term security of natural gas supply considering the estimation on rising demand
BUSINESS MODEL	Petrobras pay to Excelerate a charter freight for the FSRU	Customer (PTT and 3 rd party) pays a tariff to PTT LNG
FLNG PLAYERS	Excelerate as owner, Exmar Ship Management as operator and Petronas as final client	PTT LNG (fully owned subsidiary of PTT) as owner and operator
REGASIFICATION CAPACITY (MTPA)	5.9	5.0
STORAGE CAPACITY	173.400 m ³	320,000 m ³ (net capacity, from low level to high level alarm)
EPC	DSME	GS Engineering & Construction, KOGAS, Hanyang Corporation and Daewoo Engineering
CONSTRUCTION PERIOD	26 Months	43 Months
CERTIFICATION	IMO regulations / BUREAU VERITAS	NFPA59A and EN1473
HSE	ISO 9001, 14001, OHSAS 18001	ISO 9001, 14001, OHSAS 18001
LOCATION	NEAR SHORE FLOATING JETTY MOORED FSRU	ONSHORE TERMINAL
LNG TRANSFER	LOADING ARMS	LOADING ARMS
GAS OFFLOADING	HP LOADING ARM	HIGH PRESSURE LNG PUMP >>> LNG VAPORIZER (OPEN RACK VAPORIZER, ORV) >>> GAS PIPELINE

4.4.3 Sungai Udang, Melaka – Nearshore conversion single jetty

PETRONAS' plan for the development of the project, also referred to as Regasification Terminal (RGT) Sungai Udang, was officially announced by the Prime Minister on 10 June 2010 when he presented the 10th Malaysia Plan in Parliament.

To mark this important industry milestone, Prime Minister Dato' Sri Mohd Najib Tun Razak and Melaka Chief Minister Datuk Seri Mohd Ali Rustam today officially launched the facility in conjunction with the World Gas Conference 2012 taking place in Kuala Lumpur.

The Melaka LNG project was then estimated to cost RM 3 billion. Following the announcement, the task of developing the RGT was assigned by PETRONAS to PGB, which implemented the project on a fast-track basis to meet its completion deadline in record time and with a significantly lower cost than its original RM3 billion budget. Situated three kilometres offshore Sungai Udang, Melaka, the RGT is considered an engineering feat by the industry.

Developed based on a revolutionary design, it comprises the world's first-of-its-kind regasification unit on an island jetty, two floating storage units (FSU) and a three km subsea pipeline connecting to a new 30 km onshore pipeline that links to Petronas Gas Berhad's existing Peninsular Gas Utilisation (PGU) pipeline network.

The FSU concept has enabled the project team to save invaluable two years, compared to building onshore regasification and storage facilities. The two FSUs, formerly Tenagaclass LNG tankers owned by PETRONAS' shipping arm MISC Bhd, will be permanently berthed at the offshore jetty structure.

The conversions of the tankers into FSUs were carried out at Malaysia Marine and Heavy Engineering Holdings Bhd's shipyard in Pasir Gudang, Johor and Keppel Shipyard, Singapore.

The FSUs have been designed to be berthed for at least 20 years without the need for dry docking. The offshore jetty, which is the core of the regasification terminal, is designed to receive LNG, regasify it and deliver natural gas via the subsea pipeline to the PGU pipeline.

The terminal has a capacity to receive, store and vaporise up to 3.8 MTPA of LNG, which will be imported from various supply sources globally.

The project was developed in anticipation of future increase in gas demand in the face of depleting indigenous gas reserves, as part of PETRONAS' efforts to ensure sufficient and secure natural gas supply for Malaysia.

Its implementation has also enhanced the capability of the local players involved in the project, exposing them to new technologies and expertise that would be beneficial to their growth and the development of Malaysia's oil and gas industry.



FLNG Main Players

- Owner and operator: Petronas Gas Berhad (Owner)
- O&G Company: Petronas (Shipper)
- EPCIC Worley Parson was the primary contractor, in charge of Management, Engineering, Procurement, Construction, Commissioning, Transportation, Installation and Start-up of the Facility. Contract awarded via a design competition
- Shipyards: Malaysia Marine and Heavy Engineering Holdings Bhd's shipyard in Pasir Gudang, Johor and Keppel Shipyard, Singapore.
- Technology provider: Worley Parsons

Technological Aspects

- Feed gas: Petronas supplied LNG
- Location: 1 km offshore from Sungai Udang, Melaka (Malaysia)
- Topsides: Hamworthy technology, using propane as intermediate fluid 3,8 MTPA
- Hull: 2 converted Tenaga class LNG carriers (currently non- propelled).
- Containment: 2 tanks of 130,000 m³ each of Gaz Transport membrane system type NO88.
- Mooring & berthing: The FSUs are permanently moored to an offshore jetty
- Loading system: LNG is unloaded from LNG carriers via 5 unloading arms, The FSUs are equipped with 5 loading arms each.
- Off-loading system: HP NG arms
- Operations: The FSUs are operated by a dedicated crew

Business Aspects and Development Drivers

- Business Model: Petronas pays tariff to Petronas Gas Berhad who operated the FSRU
- Commercial Aspect: Intercompany relationship, in regulated gas market, Petronas has two LNG import agreements.

This publication is produced under the auspices of the International Gas Union (IGU) which holds the copyright. The publication must not be reproduced in whole or in part without the written permission of the IGU. However, irrespective of the above, established journals or periodicals shall be permitted to reproduce this publication, or part of it, abbreviated or edited form, provided that credit is given to IGU. This document contains strictly technical information to be distributed during the 27th World Gas Conference in Washington DC, USA, and has no commercial intent.

- The first, signed in May 2011, is with France's GDF Suez for the supply of 2.5 MTPA of LNG over 3 1/2 years.
 - The second is with Qatargas for the supply of 1.5 MTPA of LNG over 20 years, with deliveries to begin in 2013.
 - The company also has a 20-year contract to buy 3.5 MTPA of LNG from the Santos-led Gladstone LNG project in Australia, in which it holds a 27.5% stake.
- Project financing: No, directly paid
 - Main drivers:
 - Flexibility in the Malaysian PGU pipeline grid (peakshaving)
 - Fast Track Project (save invaluable two years, compared to building landbased regasification and storage facilities)
 - Challenges: First of its kind; floating, and near shore.

Case Study Conclusion

Commercial startup of the Melaka LNG terminal -- Malaysia's first LNG import facility -- has been pushed back for the second time to the April-June quarter of 2013, according to a statement from Petronas Gas, a subsidiary of state-run Petronas.

The facility achieved mechanical completion in June and was originally slated for startup in August 2012, but this was later delayed to late 2013.

The FLNG was initiated as a Fast Track project to deliver gas 2 years earlier than a conventional onshore solution. This was the main driver to install a peakshaving functionality on a fast track basis. Due to project challenges the project became not a fast track project.

References⁷

7

MALAYSIA'S FIRST LNG RE-GASIFICATION TERMINAL REACHES COMPLETION, Public Affairs & General Services Department, Corporate & Commercial Services Division, PETRONAS Gas Berhad, 4 June 2012
 Malaysia's Petronas delays startup of Melaka LNG import terminal to Q2 2013, Singapore (Platts)--26 Nov 2012 1108 pm EST/408 GMT

This publication is produced under the auspices of the International Gas Union (IGU) which holds the copyright. The publication must not be reproduced in whole or in part without the written permission of the IGU. However, irrespective of the above, established journals or periodicals shall be permitted to reproduce this publication, or part of it, abbreviated or edited form, provided that credit is given to IGU. This document contains strictly technical information to be distributed during the 27th World Gas Conference in Washington DC, USA, and has no commercial intent.

4.5 Conversion vs. New-built

There are different issues to address when comparing a new-built and a converted FSRU. CAPEX and OPEX considerations are important but also flexibility has an impact on the decision-making process. The decision to convert an LNG carrier might be supported by the fact that the regasification project has a short duration and the feasibility is higher in case of having low capital expenses.

However, new-built FSRU is basically designed as a very flexible solution that can be also used as a facility whenever regasification capacity is not any longer needed in a particular location. On the other hand, the ship-owners are looking for more candidates for FSRU conversion in the tanker market because of the depressed charter rates and uncommitted tonnage.

The following aspects are the most important to consider for the comparison.

Cost of the project

A new-built project typically with the following characteristics

- Regasification capacity: 4 – 8 MTPA
- Mooring at jetty port
- STS Transfer with hoses
- Design with minimum 20 years fatigue life
- CCS: Membrane reinforced
- Builder: South Korean yard

And has a price of approximately 250 to 300 million USD, whether a total conversion price might be lower and is basically linked to the condition of the selected ship and the scope of the conversion.

Typically, the acquisition of an older LNG carrier may be in the region of 10 to 20 million USD. Depending on the condition of the carrier a budget of approximately 5 to 10 million USD for the conversion and 10 to 15 million for the regasification plant installed would be a reasonable cost of conversion leading to a total CAPEX of 25 to 45 million USD. A conversion project like the FSRU Toscana is an exception as normally a conversion project will never exceed the new-built price to make the project feasible.

A converted FSRU might have however a higher cost related to operation as the equipment installed on board may need shorter maintenance intervals due to the aging factor.

Duration of the project

A conversion project may be ready within a period from 9 to 12 months. On the other hand, the new-built project duration may be from 30 to 36 months depending on the complexity of the ship and orderbook of the shipyard.

Regulations applicable

In principle international maritime organization (IMO) IGC code has been applicable for a new-built project. For future new-built projects the revised version (IGC 2014) will apply as it entered into force for ships keel laid on the 1st of July 2016 and after. However, for a conversion of an older LNG carrier, subject to flag considerations the conversion may be considered major and in such a case the converted ship must comply with the regulations in force at the time of the conversion start. This may lead to the necessary upgrades for ships that are only in compliance with previous regulations (IMO A.328(IX) for instance) and extra measures to implement the new regulations.

EPC companies and Shipyards involved

First class shipyards in South Korea with quality management and field supervision are mainly involved in the new-built projects as 21 ships have been already delivered by DSME, SHI and HHI. In a new-built project the yard is acting as an EPC.

On the other hand, for conversion projects, in principle, any shipyard familiar with the repair of LNG carriers may be involved as it has been the case of Keppel, Dubai Dry Dock and Jurong Shipyard.

Owners involved

The three large industry stakeholders are Exmar, Excelerate, Golar and Hoegh. However, Hoegh, Exmar and Excelerate choose new-built projects whether Golar stepped into the segment by means of several conversions.

New comers may choose conversion projects as there is tonnage available which appears inefficient considering the present market conditions.

Technical challenges, including technical limitations to carry out a conversion

New-builts are based on proven and standard designs while the scope of a conversion project may vary depending on the LNG carrier condition being a tailor-made scope and not fully proven design. Project technical challenges are addressed in the early development of the project in a new-built. A conversion project may be more iterative as design modifications might occur during the development of the conversion project and not only in the early planning of the conversion.

Fatigue life for a new-built design is in line with the industry standards so typically 40 years fatigue which is applied for a LNG carrier design while the conversion project, by definition may have reduced fatigue life unless there is a complete structural renewal.

Cargo capacities in the range of 170,000 to 175,000 m³ in four membrane tanks is quite standard for an FSRU new-built whether for conversions the typical storage volumes are in the range of 120,000 m³ to 135,000 m³. This a practical limitation for receiving terminals which need large storage capacity and also imposes a limitation taking into consideration that the new fleet calling these FSRU terminals will be mostly based on 170,000 to 180,000 m³ capacity LNG carriers.



Cargo handling items maybe more standard as well for a new-built than for a conversion. However, LNG transfer flexible hoses have been the preferred transfer system for LNG for many FSRU applications, being LNG loading arms only used in very few FSRU cases.

With regards to flexibility, considering that the FSRU new-builts are designed and constructed as LNG carriers with a standard design service life, the new-built projects offer additional flexibility to the owners. It has to be considered that some contracts recently awarded for FSRU are for durations of only 5 years.

In addition, new membrane containment systems are designed for partial filling applications, reducing deformation issues caused by sloshing and providing additional flexibility for a new-built FSRU as opposed to standard LNG carriers. Nevertheless, many of the conversions carried out are Moss type tanks which are intrinsically designed for partial filling operations.

A new-built FSRU will be designed and built to minimize harmful effects on the local environment, like as:

- No flaring of gas during normal service.
- Complete onboard sewage treatment.
- Complete onboard waste compacting or incineration plant.
- No chemical effluents.

A conversion project may have to address same issues

Business opportunities

It is a fact that due to the large amount of old tonnage available (approximately 40 LNG carriers) over 30 years, there might be a good business case for conversions to FSRU or just FSU. Cargo containment system used in most of these old ships is Moss which is normally in a good condition. In addition, the LNG carriers are equipped with steam turbines which seem not to be attractive anymore for charterers which prefer new low consumption technologies.

5 LNG FPSOs

5.1 Drivers

LNG FPSO (floating – production – storage – offloading) facilities have been discussed for many decades. Even one of the first LNG liquefaction plants has been barge-mounted in the 1950ies. However, until today very few commercial installations for floating natural gas liquefaction are in continued and profitable operation. Nevertheless, there are many factors supporting the concept to install a LNG liquefaction plant on a FPSO, which will be listed below⁸.

World scale LNG schemes include transport in LNG carriers - large ships, which require a massive marine infrastructure like jetties, berths, and so on. If no suitable shoreline is available, if waterfront access is difficult or if shipping to shore is limited, LNG FPSOs can act as technical and/or economic enabler for the project.

In many cases, natural gas fields are several hundred kilometres offshore: instead of installing an expensive subsea pipeline from the field to shore, the LNG facility can be located at the offshore field through an LNG FPSO. LNG FPSOs can be relocated with acceptable effort. Thus, they can be redirected to another field, when gas production declines, enabling the asset to be reused and avoiding the full sunk cost experienced with an onshore plant, which cannot be relocated.

Land based LNG facilities frequently are faced to long execution periods (more than five years) between FID and start-up caused e.g. by permitting issues or unexpected construction challenges. Here, LNG FPSOs can provide a fast track schedule e.g. for small/mid-size fields or if a bridge solution is required.

Many natural gas fields are in remote areas with little infrastructure. Developing such projects requires significant financial effort. If the LNG facility is built in a shipyard, with higher productivity and often lower labour rates, significant savings can be achieved in comparison to the construction of a conventional onshore liquefaction plant. In addition, 90 % of the commissioning can be completed in controlled shipyard conditions prior to installation.

World scale LNG projects require an overall budget of many billion US\$. A delay in schedule causes high expenses for interests. Shipyard construction provides a higher confidence in delivery date than many onshore construction locations and will contribute to more predictable costs. Oil FPSOs have a long tradition with different commercial arrangements like tolling or lease schemes. This approach can also be applied to LNG FPSOs avoiding the initial capital outlay.

⁸ <https://www.oxfordenergy.org/wpcms/wp-content/uploads/2017/07/The-Outlook-for-Floating-Storage-and-Regasification-Units-FSRUs-NG-123.pdf>

This publication is produced under the auspices of the International Gas Union (IGU) which holds the copyright. The publication must not be reproduced in whole or in part without the written permission of the IGU. However, irrespective of the above, established journals or periodicals shall be permitted to reproduce this publication, or part of it, abbreviated or edited form, provided that credit is given to IGU. This document contains strictly technical information to be distributed during the 27th World Gas Conference in Washington DC, USA, and has no commercial intent.

5.2 Relevant LNG FPSO projects⁹

At present (May 2018) there are only two LNG FPSOs in operation. Details about the PFLNG Satu project will be given in chapter 5.4.2, Golar Hilli will be discussed in chapter 5.5.2.

Country	Developer	Project	MTPA	Start-Up
Under Construction or in Operation				
Malaysia	Petronas	PFLNG Satu, Kanowit Field	1.2	2017
Cameroon	SNH/Perenco/Golar LNG	Kribi (Golar Hilli)	2.4	2018
Australia	Shell	Prelude	3.6	2018
Equatorial Guinea	Ophir	Fortuna (Golar Gandria)	2.2	2021
Mozambique	ENI	Coral South	3.4	2022
TBA	Exmar	Caribbean FLNG	0.5	TBA
Malaysia	Petronas	PFLNG2, Rotan Field	1.5	TBA
Total			14.8	

In addition, there are several LNG FPSO projects in various planning phases.

Country	Developer	Project	MTPA	Start-Up
Planning/Pre-engineering Phase				
Indonesia	Inpex/Shell	Abadi	7.5	On hold
USA	Excelerate Energy	Lavaca Bay	4.4	On hold
Australia	ExxonMobil	Scarborough/Thebe	6.5	TBA
Australia	Woodside	Browse FLNG1	3.6	TBA
Australia	Woodside	Browse FLNG2	3.6	TBA
Australia	Woodside	Sunrise	4.0	TBA
Cameroon	NewAge/Euroil/Lukoil	Etinde	1.0	TBA
Canada	Orca LNG	Orca LNG	4.0	TBA
Canada	Altagas/EDFT/Idemitsu	Exmar Kitimat	0.6	TBA
Congo	NewAge/SNPC	BLNG	1.0	TBA
Israel	Noble Energy	Tamar	3.4	TBA
Tanzania	Ophir/BG/Statoil	Mzia/Chaza/Jodari	2.5	TBA
USA	Delfin	Delfin LNG	5.0	TBA
USA	McMoran Exploration	Main Pass Energy	4.0	TBA
USA	Cambridge Energy	CE FLNG	2.5	TBA
Total			53.6	

⁹ [https://www.igu.org/sites/default/files/node-news_item-field_file/103419-World IGU Report FINAL LR.PDF](https://www.igu.org/sites/default/files/node-news_item-field_file/103419-World%20IGU%20Report%20FINAL%20LR.PDF)

This publication is produced under the auspices of the International Gas Union (IGU) which holds the copyright. The publication must not be reproduced in whole or in part without the written permission of the IGU. However, irrespective of the above, established journals or periodicals shall be permitted to reproduce this publication, or part of it, abbreviated or edited form, provided that credit is given to IGU. This document contains strictly technical information to be distributed during the 27th World Gas Conference in Washington DC, USA, and has no commercial intent.

5.3 Open Sea vs. Near Shore

The technical concepts and solutions for 'Open Sea' and 'Near Shore' LNG FPSOs are different and are explained below¹².

Open Sea LNG FPSOs

- Are in **open water** and are exposed to the prevailing sea state conditions for that location.
- Preferably process offshore gas, which would require a **long pipeline** to shore.
- Are weather-vaning around a **turret mooring system**.
- Frequently require **dynamic positioning** systems (thrusters).
- May require a **tandem offloading** system instead in a side-by-side LNG transfer, in case the metocean conditions are very challenging,
- Require full infrastructure for **island mode** operation.

An example of offshore configuration is shown below. For relatively benign waters e.g. Prelude (Browse Basin, Australia), LNG will be exported using a system based on a proven hard arms design with the vessels located on a side-by-side basis. However, harsher conditions e.g. Scarborough, (remote Carnarvon Basin, Australia) will require a tandem offloading arrangement with the vessels located one behind the other as used for oil offloading from FPSOs in harsh conditions. It should be noted that whilst Prelude is in normally benign conditions, the facility must be structurally designed to withstand the harsh category 5 cyclone conditions experienced in that area, albeit the facility will cease operations for the duration of those conditions.

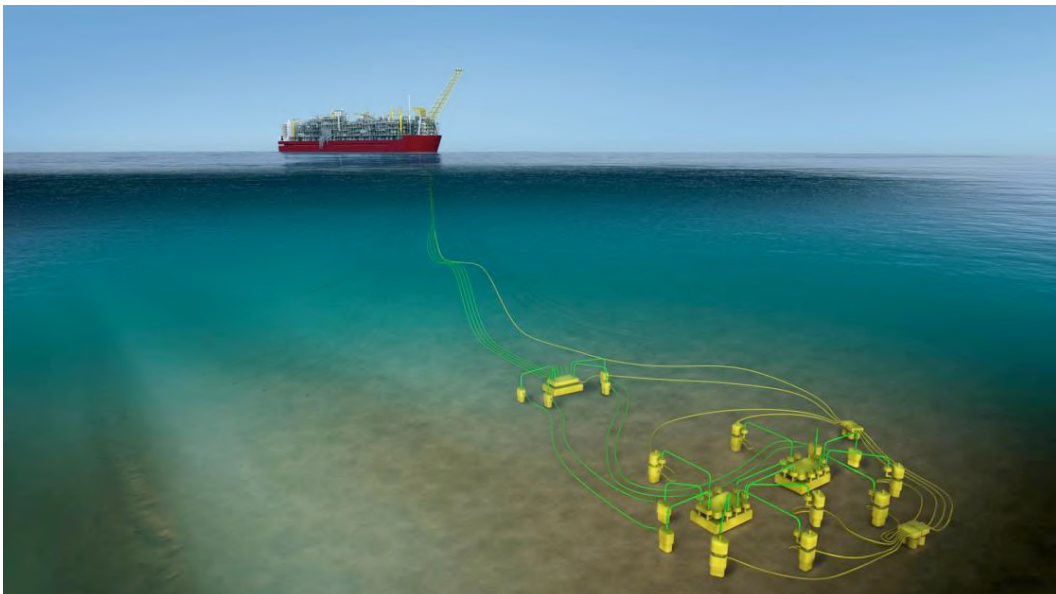

¹² <https://www.oxfordenergy.org/wpcms/wp-content/uploads/2016/11/Floating-Liquefaction-FLNG-NG-107.pdf>

This publication is produced under the auspices of the International Gas Union (IGU) which holds the copyright. The publication must not be reproduced in whole or in part without the written permission of the IGU. However, irrespective of the above, established journals or periodicals shall be permitted to reproduce this publication, or part of it, abbreviated or edited form, provided that credit is given to IGU. This document contains strictly technical information to be distributed during the 27th World Gas Conference in Washington DC, USA, and has no commercial intent.

Near Shore LNG FPSOs

- Are frequently located in relatively **benign water** conditions with the protection of a harbour or breakwater and are not exposed to harsh open ocean sea states.
- Preferably process onshore gas or offshore gas, which can be supplied by a **short pipeline**.
- Can **import electric power** and other utilities from shore.
- Do **not** need an expensive **turret**, as they are either installed on a GBS (gravity based structure) or are permanently moored.
- Offer the potential to **minimize** space for **accommodation** as operator's transfer can be organized frequently.
- do **not** need a **helideck**.
- Offer the possibility of splitting-off the **LNG storage**, making use of an FSO and therefore saving CAPEX.

An example of Near Shore configuration is shown below with the vessel moored to a jetty. With these configurations, the feed gas is normally supplied by pipeline from the producing field (or from a main transport pipeline), which may be on- or offshore.



5.4 Case studies LNG FPSO Open Sea

To illustrate the LNG FPSO's various facts and differentiators two relevant Open Sea projects have been selected and compared with similar land-based LNG projects.

- Shell's world-scale Prelude FLNG is compared with the Sakhalin II LNG plant as both plants have relevant similarities in technology and capacity.
- Petronas FLNG Satu is compared with the mid-scale onshore LNG plant in Stavanger/Risavika as both plants use less complex liquefaction processes.

5.4.1 Prelude FLNG

Prelude is the largest offshore facility ever constructed. It will be located 475 km away from north-east of Broome (200 km from nearest land), Browse Basin in Western Australia. The water depth is less than 250 meters. The main onshore supply base is located in Darwin Australia. The names of gas fields are Prelude and Concerto and normal feed gas rate is 680 MMSCFD. Prelude has been the first LNG FPSO project to take FID (May 20, 2011), but Prelude may start the full capacity production from 2018 only. It looks not so much faster than general onshore LNG projects, because it is biggest floating LNG facility worldwide¹³ and a sort of first of a kind.

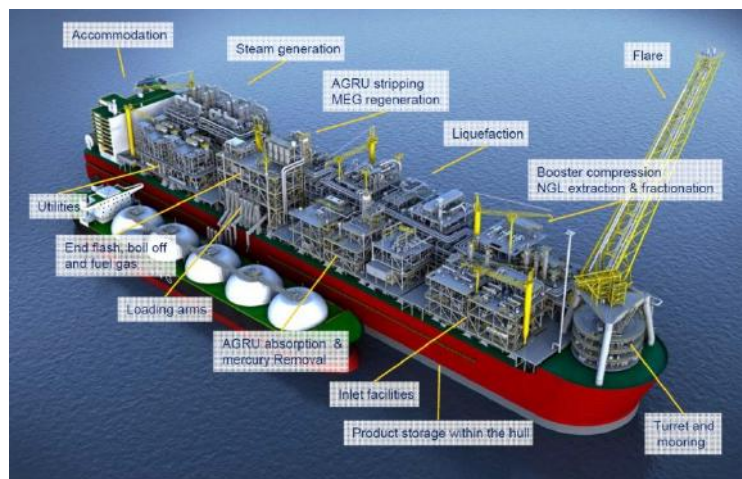

Shell is a major shareholder (67.5 % share) of Prelude project. INPEX holds 17.5 %, KOGAS holds 10 %, and CPC holds 5 % of the shares. The front-end engineering and design (FEED) of the facility was undertaken by Technip. EPC contractor is the Technip and Samsung Heavy Industries Consortium and it has been constructed in the shipyards of Samsung Heavy Industries¹⁴.

Prelude is designed for 25 years operation; hull parts are designed for 50 years. The selected liquefaction process is Shell DMR with 3.6 MTPA (in two trains of 1.8 MTPA each) LNG production capacity. Prelude can also produce 1.3 MTPA condensates and 0.4 MTPA LPG. The production is stored in 6 LNG tanks (total 221,000 m³), 4 LPG tanks (total 90,000 m³), and 6 condensates tanks

¹³ Prelude FLNG General Introduction, 33rd FPSO Research Forum, 2014

¹⁴ <https://www.shell.com/about-us/major-projects/prelude-flng.html>

This publication is produced under the auspices of the International Gas Union (IGU) which holds the copyright. The publication must not be reproduced in whole or in part without the written permission of the IGU. However, irrespective of the above, established journals or periodicals shall be permitted to reproduce this publication, or part of it, abbreviated or edited form, provided that credit is given to IGU. This document contains strictly technical information to be distributed during the 27th World Gas Conference in Washington DC, USA, and has no commercial intent.

(total 126,000 m³). For the pre-treatment, there are aMDEA type AGRU and molecular sieve 3 bed type dehydration processes. Turbo expander type NGL extraction process is used to separate NGL from the feed gas. Therefore, Prelude is a huge floating facility, which has external dimensions of 488 m length, 74 m wide, 42 m depth and around 600,000 tons for fully ballasted case. Prelude has been designed and constructed to withstand category 5 cyclones. Lloyd's Register has checked the safety of the hull and topside including turret equipment. FMC Technologies has prepared the subsea production trees and manifolds, risers and subsea control systems, and SBM Offshore has manufactured the turret and mooring system¹⁵.

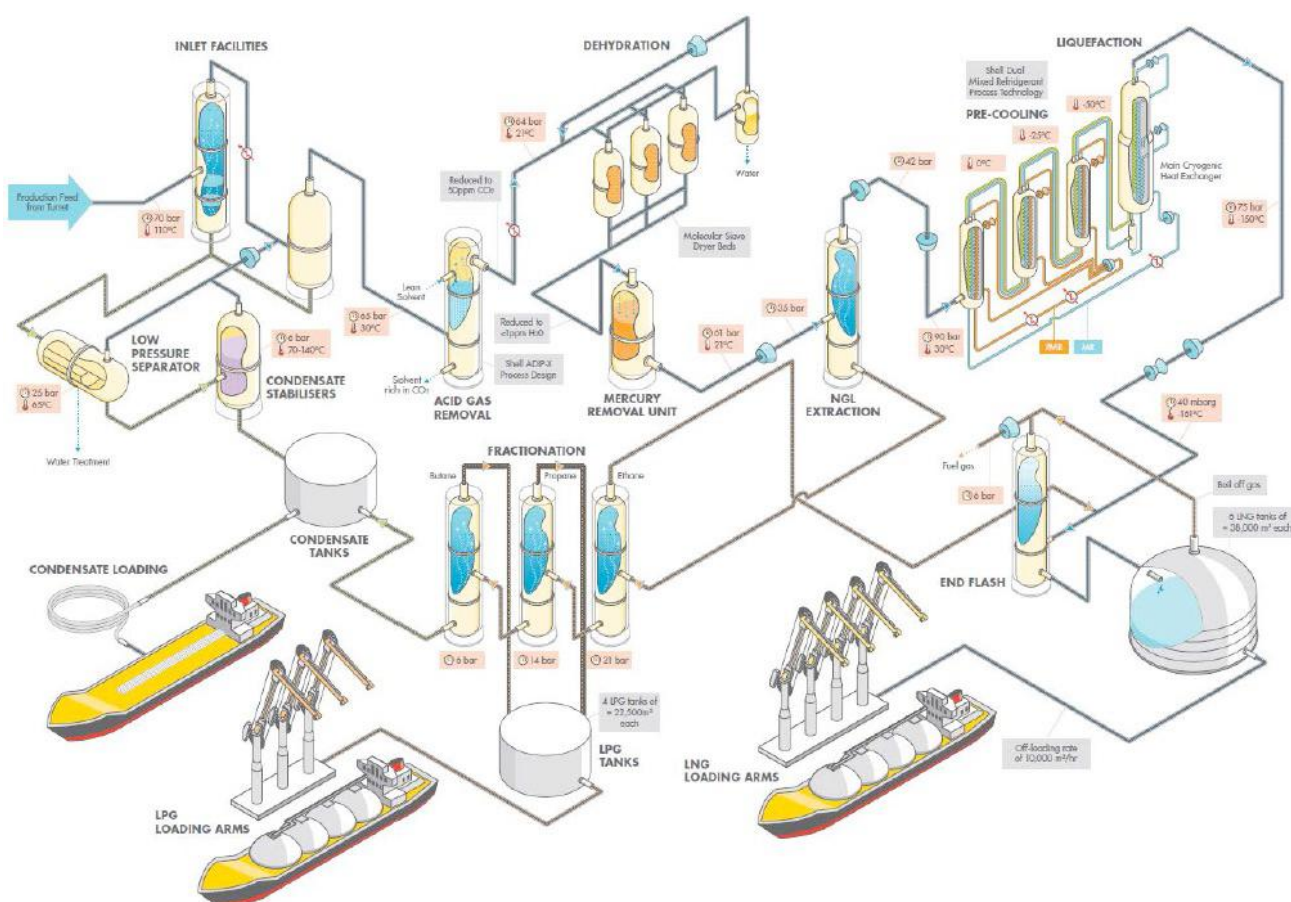

Air Products has supplied the MCHE LNG heat exchanger system. The control and monitoring technologies have been prepared by Emerson. FMC Technologies has manufactured the offshore loading arm systems. The refrigerant compressors are driven by steam turbines (GE Oil & Gas). In total, there are 7 steam boilers (Kawasaki Heavy Industries) on the topside and electric power is also generated from steam turbine generators (Mitsubishi Heavy Industries Compressor Corporation). The amount of cooling water for heat rejection from the process is about 50,000 m³/h of sea water from 150 m depth¹⁶.

¹⁵ Prelude FLNG Project, DOT conference presentation, 2012.

¹⁶ <http://www.offshore-technology.com/projects/shell-project/>

This publication is produced under the auspices of the International Gas Union (IGU) which holds the copyright. The publication must not be reproduced in whole or in part without the written permission of the IGU. However, irrespective of the above, established journals or periodicals shall be permitted to reproduce this publication, or part of it, abbreviated or edited form, provided that credit is given to IGU. This document contains strictly technical information to be distributed during the 27th World Gas Conference in Washington DC, USA, and has no commercial intent.

Prelude LNG-FPSO has been completely constructed in SHI shipyard South Korea. Prelude left SHI shipyard on June 29, 2017 and then arrived in North East Australia on July 25¹⁷. Prelude project had a plan for the hot commissioning of LNG and LPG within 2017. First LNG cargo is expected in 2018¹⁸.

Sakhalin II (onshore comparison case)



Sakhalin II is one of the world's largest integrated, export-oriented oil and gas projects, as well as Russia's first offshore gas project. Sakhalin Energy Investment Company Ltd., the project operator, is owned by Gazprom, Shell, Mitsui and Mitsubishi. The project infrastructure includes three offshore platforms, an onshore processing facility, 300 km of offshore pipelines and 1,600 km of onshore pipelines, an oil export terminal and a liquefied natural gas (LNG) plant¹⁹.

Sakhalin II project has unique features for the following perspectives

- Russia's first LNG plant: it was commissioned in 2009, it had been constructed since August 2003.
- Russia's first PSA (production sharing agreement)-based project, Gazprom and the Sakhalin Energy shareholders signed the Purchase and Sale Agreement, pursuant to which Gazprom acquired a 50 % stake plus 1 share in Sakhalin Energy
- The first offshore oil and gas producing platforms installed in Russia

There are several main players in this project. Sakhalin Energy Investment Company Ltd. (Sakhalin Energy), who is the Sakhalin II project operator, was established in April 1994. Sakhalin Energy shareholders are Gazprom Sakhalin Holdings B.V. (a subsidiary of Gazprom – 50 % plus one share), Shell Sakhalin Holdings B.V. (a subsidiary of Royal Dutch Shell plc. – 27.5 % minus one share), Mitsui Sakhalin Holdings B.V. (a subsidiary of Mitsui & Co., Ltd. – 12.5 %) and Diamond Gas Sakhalin B.V. (a subsidiary of Mitsubishi Corporation – 10 %). CTSD (Chiyoda Toyo Sakhalin Development Limited) was selected as EPCM (Engineering, Procurement and Construction Management) Contractor with Chiyoda for the LNG trains and Toyo for utilities, infrastructure and adjacent Oil Export Terminal²⁰.

¹⁷ <https://www.shell.com/about-us/major-projects/prelude-flng.html>

¹⁸ <http://www.ebn.co.kr/news/view/898759>

¹⁹ <http://www.gazprom.com/about/production/projects/lng/sakhalin2/>

²⁰ <http://www.sakhalinenergy.ru/en/index.wbp>

This publication is produced under the auspices of the International Gas Union (IGU) which holds the copyright. The publication must not be reproduced in whole or in part without the written permission of the IGU. However, irrespective of the above, established journals or periodicals shall be permitted to reproduce this publication, or part of it, abbreviated or edited form, provided that credit is given to IGU. This document contains strictly technical information to be distributed during the 27th World Gas Conference in Washington DC, USA, and has no commercial intent.

In June 2008 Sakhalin Energy signed Russia's largest project finance deal, securing a loan of USD 5.3 billion from the Japan Bank for International Cooperation and a consortium of international banks. Japan Bank for International Cooperation provided USD 3.7 billion of the funds. Contracts for the supply of LNG have been signed. Up to 60 % of the LNG from the project is exported to customers located in Japan, while the remaining volumes are exported to South Korea, Taiwan, China, Kuwait, the US and Thailand²¹.

The plant's design capacity is 4.8 MTPA for each of the two trains with feed gas quality of low nitrogen (<1 mol%) and carbon dioxide (<1 mol%) and LNG HHV at about 1090 Btu/scf (GPA). Gas inlet stations are provided to remove traces of dust and liquids. As gas pre-treatment facilities: CO₂ removal with Shell SULFINOL-D sour gas treating process; and dehydration by a 3-bed molecular sieve, followed by a mercury guard bed are configured.

The proprietary Shell DMR liquefaction technology with air cooling is applied. For each liquefaction train, two Linde coil wound exchangers (pre-cooling down to -50°C) and a Linde MCHE (liquefaction and sub-cooling down to -160°C) are installed in a 2x 50 % configuration. Two GE Frame 7 gas turbine drivers are provided for the cycles compressors. Shell DMR technology had been adopted for the first time in the world because of the cold climate in Sakhalin, i.e. much better operational flexibility in case of large ambient temperature variation between summer and winter than C3MR. Coil wound heat exchangers in the MR pre-cooling cycle are selected instead of kettle-type exchangers in C3MR process. Air-cooling is used instead of seawater cooling for cost, capacity and environmental performance. Winterization of equipment has been applied to enable maintenance work during winter, i.e. shelters with heating facilities, anti-icing facilities for air inlet system on air compressors and gas turbines, electrical heat tracing on piping, rotating equipment and even beneath the LNG storage tanks. Hot oil is selected as heating medium considering its freezing point below the minimum ambient temperature in Sakhalin. Cold weather protection for civil foundation stability such as thermally insulated piles and snow-clearing equipment is readily available on site. Two 100,000 m³ double-wall storage tanks with the inner tank made of 9 % nickel and the outer tank of two layers (9 % nickel steel/reinforced concrete) are also provided. Parallel start-up of the upstream gas supply via the new pipeline system was very challenging and became the critical path of the overall project schedule. After completion of most commissioning activities relying on imported LNG, several start-up activities for the first DMR start-up were taken²².

The LNG plant was commissioned in February 2009 and the first cargo from the plant to Japan was shipped in March 2009. The second train of the LNG plant started operations in May 2009. Overall construction work for the project was completed in 2009. More than 25,000 people worked at the project at the peak of its construction. The 100th LNG shipment from Prigorodnoye Complex was

²¹ <https://en.wikipedia.org/wiki/Sakhalin-II>

²² Sakhalin Energy's Initial Operating Experience from Simulation to Reality: Making the DMR Process work, Shell Global Solutions International, 2012-06-15, <http://www.shellglobalsolutions.com>

This publication is produced under the auspices of the International Gas Union (IGU) which holds the copyright. The publication must not be reproduced in whole or in part without the written permission of the IGU. However, irrespective of the above, established journals or periodicals shall be permitted to reproduce this publication, or part of it, abbreviated or edited form, provided that credit is given to IGU. This document contains strictly technical information to be distributed during the 27th World Gas Conference in Washington DC, USA, and has no commercial intent.

achieved in January 2010 and the 200th LNG cargo was delivered in October 2010. The LNG plant reached its full production capacity of 9.6 MTPA in 2010.

The Sakhalin II project has set new standards in social and environmental performance and transparency in Russia. The northeast coast of Sakhalin Island is rich with marine life and is a summer feeding area for the critically endangered Western Gray Whale (WGW). In 2005 the project accepted the recommendations of the Independent Scientific Review Panel (set up under the International Union for Conservation of Nature) and re-routed the offshore pipelines to avoid whale-feeding areas. In 2006, in cooperation with IUCN, the Western Gray Whales Advisory Panel was established to provide advice to minimize risks from oil and gas developments in whale habitats²³.

Comparison Prelude FLNG vs Sakhalin II

Sakhalin II Onshore LNG plant has been chosen as comparison of offshore project (Shell Prelude) and summarized by below table.

	Prelude FLNG	Sakhalin II
Production Capacity	3.6 MTPA (1.8 x 2 trains) 5.3 MTPA taking total liquid production	9.6 MTPA (4.8 x 2 trains) train of 5.4 MTPA to be added by 2021
EPC Schedule	About 7 yrs (May 2011 to 2Q 2017) plus another 1 yr for transportation/hook-up/commissioning/start-up is assumed	About 6 yrs (Aug 2003 to May 2009)
Sites / Construction sites	Prelude field, 475 km north-east of Broome, Browse Basin, Western Australia Geoje shipyard, Samsung Heavy Industry, South Korea	Prigorodnoye production complex, Sakhalin Island, Russia
Contractors (including shipyards)	Technip Samsung Consortium	CTSD (Chiyoda Toyo Sakhalin Development Limited)
Technology	Shell DMR liquefaction technology - 60 MW (rated) Steam Turbines for PMR cycle and MR cycle each - Seawater/Closed Cooling water	Shell DMR liquefaction technology - Two gas GE Fr7 turbine drivers for the pre-cool/liquefaction cycles - Air cooling
Drivers	Floating liquefied natural gas (FLNG) is a revolutionary technology that will allow Shell to access offshore gas fields that would otherwise be too costly or difficult to develop.	
Shareholders	Shell 67.5%, INPEX 17.5%, CPC 5%, KOGAS 10%	Gazprom 50% (plus one share), Shell 27.5% (minus one share), Mitsui 12.5%, Mitsubishi 10%

²³ <http://www.shell.com/about-us/major-projects/sakhalin/sakhalin-an-overview.html>

This publication is produced under the auspices of the International Gas Union (IGU) which holds the copyright. The publication must not be reproduced in whole or in part without the written permission of the IGU. However, irrespective of the above, established journals or periodicals shall be permitted to reproduce this publication, or part of it, abbreviated or edited form, provided that credit is given to IGU. This document contains strictly technical information to be distributed during the 27th World Gas Conference in Washington DC, USA, and has no commercial intent.

5.4.2 Petronas FLNG1 (Satu)

PFLNG1²⁴ (Satu) is the first operational LNG FPSO facility worldwide. This is a major achievement and deserves high respect in times of low LNG market prices. Designed to last up to 20 years without dry-docking, the 365-meter long PFLNG 1 is expected to be able to produce 1.2 MTPA LNG per year. The front-end engineering and design (FEED) of the facility was undertaken by Technip Daewoo Consortium (TDC), a joint-venture (JV) between Technip and Daewoo Shipbuilding & Marine Engineering (DSME). TDC received the FEED contract from Petronas Floating LNG 1 (Labuan), a subsidiary of PETRONAS, in December 2010 and was also responsible for the construction of the facility. FID was taken in March 2012.

Air Products signed an equipment and process license agreement for the project's use of Air Products' AP-N™ LNG process and equipment. The parts of the proprietary equipment have been built at different plants and assembled into modules. The coil wound heat exchangers and compressor-expanders have been built in Wilkes-Barre and Fogelsville plants in Pennsylvania, US, respectively. The economizer cold boxes have been built in Tanjung Langsat, Malaysia. Honeywell's wholly owned subsidiary UOP provided its UOP Amine Guard FS process to remove carbon dioxide and hydrogen sulfide from the LNG feed streams. GE Oil & Gas supplied gas turbine-driven compressor train technology, comprising four PGT25+G4 gas turbine generator systems, two PGT25+G4 gas turbine driven compressor units and two electric motor driven centrifugal compressors modules, all of which are used to cool the natural gas in the LNG FPSO.

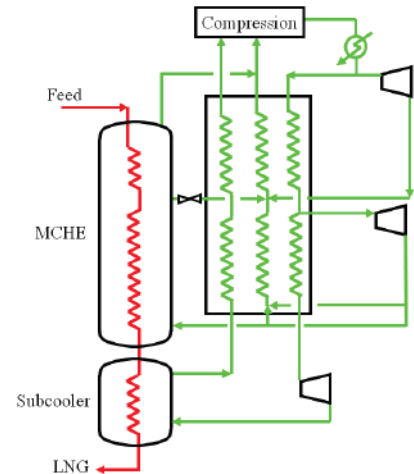

PFLNG1 reached its final stages of commissioning and startup with the introduction of gas from the KAKG-A central processing platform at the Kanowit gas field on November 14, 2016²⁵. LNG production started on December 5, 2016. Kanowit has been exporting gas to the Malaysia LNG plant at Bintulu. The intention is to test-produce PFLNG1 at an existing field for around five years. Once it is proven successful, PFLNG1 can easily be modified and mobilized for production in other fields. Apart from other economic drivers, somehow PFLNG1 was driven by a strategic decision from

²⁴ <https://www.petronasofficial.com/floating-lng/project>

²⁵ <http://www.petronas.com.my/media-relations/media-releases/Pages/article/FIRST-GAS-FOR-PETRONAS%E2%80%99-FIRST-FLOATING-LNG-FACILITY,-PFLNG-SATU.aspx>

This publication is produced under the auspices of the International Gas Union (IGU) which holds the copyright. The publication must not be reproduced in whole or in part without the written permission of the IGU. However, irrespective of the above, established journals or periodicals shall be permitted to reproduce this publication, or part of it, abbreviated or edited form, provided that credit is given to IGU. This document contains strictly technical information to be distributed during the 27th World Gas Conference in Washington DC, USA, and has no commercial intent.

Petronas to have a positioning in the emerging LNG FPSOs niche, gaining experience for developing gas resources that due to distance to shore and/or size were not that much economic through an onshore conventional LNG producing facility.

Stavanger/Risavika LNG (onshore comparison case)

The Risavika LNG plant²⁶, located in the harbour area of Stavanger/Norway has been started up in 2010 after three years of engineering and construction. Lean feed gas is available at elevated pressure (>100 bar) from the Karstø gas processing plant north of Stavanger. The plant (except the LNG tank shell) has been designed and built by Linde Engineering based on a turnkey lump sum contract. Pretreatment including mercury removal, sour gas scrubbing (aMDEA) and dehydration using molecular sieves is designed like in a world scale LNG plant. The optimized single mixed refrigerant (SMR) process LIMUM[®]3 has been selected due to its simplicity and efficiency. With 900 t/h liquefaction capacity this plant is a typical mid-scale LNG plant.



The three-bundle coil wound heat exchanger is manufactured by Linde Engineering fully in stainless steel (shell and bundles). The integrally geared mixed refrigeration cycle compressor has been supplied by

Siemens together with a variable speed electric motor (VSDS).

Originally, the plant has been invested by the Lyse Group, a Norwegian utility provider. Later, the plant has been acquired by the Finnish Gasum Oy via its Norwegian subsidiary Skangass. Most of the LNG product is sold in Scandinavia and around the Baltic Sea to mid-scale LNG import terminals like Lysekil and Nynäshamn/Sweden. Many ferries in the Baltic ECA²⁷ (emission control area) are operated with fuel originating from Risavika LNG. However, the local market is still not large enough to justify the installation of the second liquefaction train.

Comparison Petronas FLNG1 vs. Stavanger LNG

Mid-scale LNG plants must defend their business model against small scale plants, which serve a local retail market and world scale LNG plants, which supply energy over long distances.

²⁶ <https://www.skangas.com/supply-chain/terminals--plants/liquefaction-plant-risavika/>

²⁷ <https://www.dnvgl.com/news/imo-nox-tier-iii-requirements-to-take-effect-on-january-1st-2016-51970>

This publication is produced under the auspices of the International Gas Union (IGU) which holds the copyright. The publication must not be reproduced in whole or in part without the written permission of the IGU. However, irrespective of the above, established journals or periodicals shall be permitted to reproduce this publication, or part of it, abbreviated or edited form, provided that credit is given to IGU. This document contains strictly technical information to be distributed during the 27th World Gas Conference in Washington DC, USA, and has no commercial intent.

Risavika LNG originally was intended to supply energy to the Scandinavian and Baltic Sea market. Unfortunately, the ECA did not boost the business as expected, as fines for violating certain emissions are moderate so that the pressure to convert from heavy fuel oil to LNG in the shipping industry is still low. Thus, Risavika LNG nowadays is not only a liquefaction terminal, but also a trading hub with LNG supply e.g. from the Gate Terminal in Rotterdam. In 2015 Skangass announced that the first ever bunkering station for LNG in the Nordics is open and operating successfully. The new bunkering station fuels Fjord Line's cruise ferries, which are the first - and largest - in the world to use "single fuelled LNG engines," meaning that they are powered exclusively by LNG.

	PFLNG1²⁸ (Satu)	Stavanger/Risavika LNG²⁹
Owner	Petronas	Gasum/Skangass
Feed source	Kanowit Gas Field	Sales Gas from Karstø
Capacity	2x 1800 t/h	900 t/h
EPC Schedule	FID 3/2012 Start-up 12/2016	FID 06/2007 Start-up 08/2010
Storage tank	GTT No96, 177,000 m ³	Flat bottom, full containment 30,000 m ³
Liquefaction process	Nitrogen expander process AP-N TM	Single mixed refrigerant process LIMUM [®] 3
Main driver	2x GE PGT25+G4 2x 34 MW ISO	VSD electric motor
Energy consumption	> 370 kWh/t	< 290 kWh/t
Cooling medium	Sea water	Air

Loading arms are part of a well-known method of transferring cargo for large oil and LNG terminals. At Risavika LNG the first ever loading arm is in operation, which has been developed purely for bunkering. LNG ships have normally been bunkered via hose connections from a truck or a tank. In contrast to Risavika LNG, which implements proven equipment and technology, the Petronas floater 1 (PFLNG1) is a ground-breaking project. It did implement for the first-time natural gas liquefaction offshore in a commercial scale. The decision to rely on very safe and robust liquefaction technology underlines the endeavour to demonstrate the overall feasibility of FLNG without pushing factors like fuel efficiency to the limit. In addition, the early phase of testing the facility at fully developed production wells shows clearly a no-risk approach with the objective to qualify new technology under very controlled conditions. PFLNG1 should be understood as final step towards floating LNG with a standard capacity in the range of 3-6 MTPA.

²⁸ http://www.technip.com/sites/default/files/technip/fields/publications/attachments/petronas-flng-satu_march.pdf

²⁹ https://www.linde-engineering.com/internet.global.lindeengineering.global/en/images/LNG_3_3_e_11_150dpi_NB19_15617.pdf?v=4.0

This publication is produced under the auspices of the International Gas Union (IGU) which holds the copyright. The publication must not be reproduced in whole or in part without the written permission of the IGU. However, irrespective of the above, established journals or periodicals shall be permitted to reproduce this publication, or part of it, abbreviated or edited form, provided that credit is given to IGU. This document contains strictly technical information to be distributed during the 27th World Gas Conference in Washington DC, USA, and has no commercial intent.

5.5 Case studies LNG FPSO Near Shore

To illustrate the various facts and differentiators of LNG FPSOs two relevant Near Shore projects with different fabrication and construction concepts have been selected.

- Pacific Rubiales' small scale Caribbean FLNG is a new-built barge.
- Golar Hilli is a conversion of a Moss type LNG carrier.

5.5.1 Caribbean FLNG

Caribbean FLNG was stated to be the first of its kind, with commercial operations expected to start prior to Shell's and Petronas' larger offshore LNG FPSOs units. The overall project involved the construction of a pipeline between the La Creciente gas field and the Caribbean coast of Colombia, as well as the development of a liquefaction barge, the Caribbean FLNG (and a regasification unit, a mandate by the government to allow for potential LNG imports into Colombia as well).

Main Players

- Pacific Rubiales Energy (now Pacific E&P, PEP), who owned and operated La Creciente field.
- Exmar: owner and operator (BOO model) of the FLNG, per contract in 2012.
- Wison Offshore & Marine: EPCIC contractor to Exmar, engineered, designed and constructed the vessel from its shipyard in Nantong, China.

La Creciente field, discovered by Pacific Rubiales in 2006, was to be the main source of feed gas for the liquefaction project. The field is located in the La Creciente Block, situated in North Colombia near Cartagena. La Creciente started production in 2008.

The 2P gas reserves amount to 612 BCF. There are minimal condensates quantities associated with the field. Apart from La Creciente, there were a few prospects that were planned to provide feedstock for Caribbean FLNG in the longer term. Feed gas would be supplied through a new 88 km, 18" diameter pipeline between the gas field and the Colombian Atlantic Coast (to the port of Coveñas). Gas would be transported using the services of Promigas.

Wison was initially awarded an EPCIC contract to build an FLRSU (Floating liquefaction, regasification storage unit) in 2012 and began construction. However, in Q1 2014, Exmar and Pacific E&P announced a new development concept based on an FSU (floating storage unit) and a separate barge-based FLU (floating liquefaction Unit, with just a small storage buffer). The FLU unit is a non-propelled barge that will be able to convert 69.5 MMSCFD of natural gas into approx. 0.45 MTPA of LNG. LNG production facilities and process equipment are located on the topside deck.

The liquefaction unit uses PRICO single mixed refrigerant LNG technology from Black & Veatch. The barge is 144 m long, 32 m wide and 20 m deep, and has an operating draft of 5.4 m. The unit would be moored 3 km offshore Tolu, to a jetty in 15 m water depth. The structure has self-developed leg mooring that allows it to remain horizontally. 3 storage tanks weighing 395 t each and having a combined capacity of 16,100 m³ are installed on board. Additionally, 138,000 m³ are fitted at separate floating storage unit (FSU). The LNG storage tanks were provided by TGE.



A key requirement for the LNG FPSO is to be able to stay moored at the jetty for at least 15 years without the need to dry dock. The biggest barrier to this kind of extended dry-docking interval is the protection of the hull which includes the prevention of corrosion and the ability to effectively deal with biofouling.

The project was developed on a time charter basis (BOO), thus Pacific E&P had the rights to the offtake. Exmar was to fully own and operate the LNG FPSO unit and Pacific E&P had exclusive rights to liquefy gas through the facility for 15 years in exchange to a fee. Pacific E&P was responsible for marketing the output and in 2014 signed a sales arrangement with Gazprom Marketing & Trading: for 5 years for all the output of 0.5 MTPA, on FOB basis. The contract was annulled with the cancellation of the project in March 2016.

In 2012 Exmar signed an agreement with the IFC (International Finance Corporation) and China Export-Import Bank for a financing facility of up to USD 280 million for its liquefaction barge to be built and chartered to Pacific E&P. In 2014 it was reported that the IFC led with an initial USD 75 million investment and a wide group of other lenders provided USD 107 million. The IFC was financing the Colombian plant as part of a USD 2 billion investment in energy projects in Central America and the Caribbean basin over some years. The total project was financed with up to 80 % debt and 20 % equity. Later it was reported that Exmar, in 2015, signed a USD 198.4 million deal with Industrial and Commercial Bank of China (ICBC) for Caribbean FLNG.

From FID, taken in April 2012, the production was planned to begin in Q2 2015. Due to change in the original technical plan in 2013 in favour of a separate FSU to dock near the FLU the construction experienced certain delay and was fully concluded in Q2 2016. However, because of changed market conditions, in March 2016 partners decided to terminate the agreement.

This publication is produced under the auspices of the International Gas Union (IGU) which holds the copyright. The publication must not be reproduced in whole or in part without the written permission of the IGU. However, irrespective of the above, established journals or periodicals shall be permitted to reproduce this publication, or part of it, abbreviated or edited form, provided that credit is given to IGU. This document contains strictly technical information to be distributed during the 27th World Gas Conference in Washington DC, USA, and has no commercial intent.

Pacific Rubiales had quite strong upstream base with the field already in production and a potential upside of feedstock. The plant capacity was easier to execute compared to larger offshore LNG FPSO projects in construction at that time. The project also had a sales arrangement deal, although not long-term agreement, but was committed to a strong gas offtaker. Gazprom planned to supply Caribbean market or Central America.

Increased internal gas demand in Colombia resulted in country's preference to secure these volumes for potential gas shortages in the medium term. Furthermore, changed environment of low oil prices damaged Pacific E&P. In 2015 company's share price fell the most in five years amid concerns over lower oil prices and debt. Later, Pacific E&P announced to scale back on its spending. Because of the domestic gas market conditions, global low oil prices environment, deteriorating financial situation of Pacific E&P, it was uneconomic for the partners to continue developing the project. However, the Caribbean FLNG unit is already built, commissioned and ready for being deployed in another producing project. Exmar, the FLU owner, is actively marketing this capacity availability.

References³⁰

-
- ³⁰ <http://www.offshore-technology.com/projects/caribbean-flng-project/>
<http://bv.com/Projects/exmar-floating-lng-liquefaction-unit>
<http://www.lngworldnews.com/exmar-pep-cancel-caribbean-flng-deal/>
<http://worldmaritimeneeds.com/archives/189154/exmar-renegotiating-caribbean-flng-funding/>
<http://www.oedigital.com/oe-media/oe-videos/item/10530-caribbean-flng-time-lapse>
<http://www.safety4sea.com/exmar-chooses-ecospeed-to-coat-caribbean-flng/>
<http://fairplay.ihs.com/commerce/article/4263921/exmar-and-pacific-break-off-colombian-flng-deal>
<https://ihs.com/Energy/Products>
<http://www.gasprocessingnews.com/news/exmar-chooses-ecospeed-to-coat-hull-of-caribbean-flng-project.aspx>
<http://www.hellenicshippingnews.com/pacific-rubiales-cuts-2015-forecast-amid-oil-slump-debt-concern/>
<http://colombiareports.com/lng-plant-colombia-funded-world-bank/>
https://www.moodys.com/research/Moodys-downgrades-Pacific-Rubiales-ratings-to-Ba3-negative-outlook--PR_328114
<http://www.prnewswire.com/news-releases/pacific-rubiales-announces-us320-million-sale-of-interest-in-pacific-midstream-to-ifc-286078851.html>
<http://www.offshore-mag.com/articles/2016/03/online-exclusive-weak-market-sinks-flng-plans.html>
<http://www.lngworldshipping.com/news/view,smallscale-lng-supplement-a-new-era-of-floating-smallscale-lng-regasification-42669.htm>
<http://www.exmar.be/en/investors/news/icbc-provides-financing-chinas-biggest-export-project-belgium>

This publication is produced under the auspices of the International Gas Union (IGU) which holds the copyright. The publication must not be reproduced in whole or in part without the written permission of the IGU. However, irrespective of the above, established journals or periodicals shall be permitted to reproduce this publication, or part of it, abbreviated or edited form, provided that credit is given to IGU. This document contains strictly technical information to be distributed during the 27th World Gas Conference in Washington DC, USA, and has no commercial intent.

5.5.2 Golar Hilli

Golar LNG, Perenco and SNH have been developing an LNG FPSO export project located near shore off the coast of Cameroon situated in an area of benign sea conditions and utilizing Golar's floating liquefaction technology. The aim is to offer a low-cost, fast-track solution for stranded gas projects that are too small to justify a larger-scale LNG development, and for areas with surplus supply of pipeline gas that needs to be sent to new markets. The vessel was named Hilli Episeyo³¹ at a ceremony in Keppel Shipyard on July 2, 2017 being at its final leg towards completion in Singapore³²; and left Singapore for Cameroon in autumn 2017. Hilli Episeyo dispatched its inaugural cargo on 17 May 2018³³.

SNH (Société Nationale des Hydrocarbures) and Perenco are owners of the upstream joint venture³⁴. Gazprom's subsidiary, Gazprom marketing & trading Singapore pte Ltd (GM&TS), has signed an agreement to buy all liquefied natural gas (LNG) from Hilli Episeyo export.

Hilli Episeyo is the world's first converted LNG FPSO owned and operated by Golar Hilli Corp., a subsidiary of Golar LNG Ltd. EPC contract signed in June 2014 with Keppel for conversion of Hilli into an LNG FPSO. Keppel Shipyard was awarded a USD 735 million contract to convert an LNG carrier into the LNG FPSO for Golar Hilli Corp in 2014³⁵. In September 2014, the Hilli arrived at the Keppel Shipyard in Singapore where the all conversion-related construction services took place. It was expected to complete the conversion in 31 months.

Feed stock comes from a stranded gas reservoir containing 500 bcf of gas, located in the Sanaga South and Ebome fields, from offshore Kribi fields to feed the project. The Kribi field is in nearshore waters off Cameroon and is operated by Perenco and Cameroon state oil company SNH, which will be exported to global markets via the GoFLNG facility.

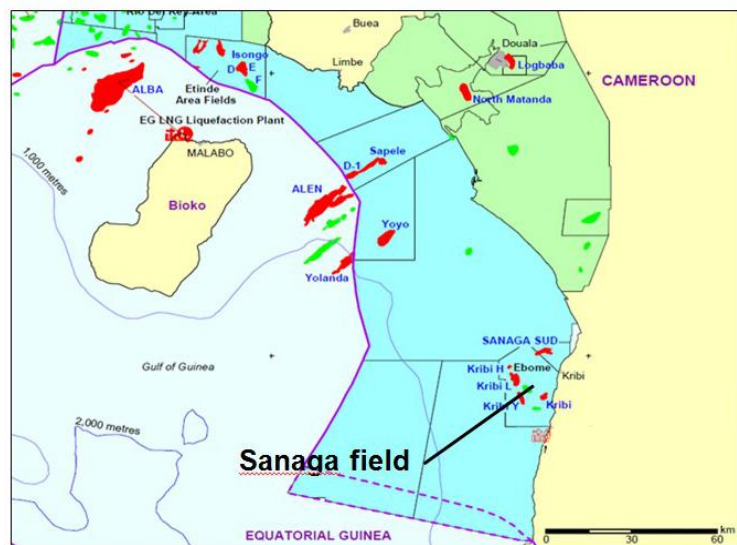

³¹ <http://www.oedigital.com/drilling/item/15707-keppel-to-deliver-hilli-episeyo>

³² <http://www.lngworldnews.com/golar-firms-cameroon-flng-deal-with-perenco/>

³³ http://www.lngworldshipping.com/news/view,cameroon-becomes-20th-lng-exporter-with-ihilli-episeyois-first-cargo_51864.htm

³⁴ <http://www.offshoreenergytoday.com/golar-signs-flng-deal-with-cameroon/>

³⁵ <http://www.businesstimes.com.sg/companies-markets/keppel-om-to-deliver-worlds-first-converted-flngv>

This publication is produced under the auspices of the International Gas Union (IGU) which holds the copyright. The publication must not be reproduced in whole or in part without the written permission of the IGU. However, irrespective of the above, established journals or periodicals shall be permitted to reproduce this publication, or part of it, abbreviated or edited form, provided that credit is given to IGU. This document contains strictly technical information to be distributed during the 27th World Gas Conference in Washington DC, USA, and has no commercial intent.

The vessel was converted from a 1975 built Moss LNG carrier with a storage capacity of 125,000 m³. Two 206.3 m long, 10.5 m wide sponsons were added on both sides of the hull to house the topside equipment comprising of pre-treatment systems and four-train vessel with a modularized design that would give the converted vessel a total capacity of about 2.4 MTPA.



Keppel has entered a topside sub-contract with EPCC, Black & Veatch as liquefaction technology provider. Mooring and berthing are adaptable to various mooring concepts including jetty, spread-mooring or SPM type systems and it is a side-by-side mooring. Berthing assisted by 2-3 tugs while Hilli is equipped with side-by-side offloading arms using industry standard maritized equipment and operating

procedures. Offloading feasible carriers up to 180,000 m³ with maximum rate of 10,000 m³/h. Four Marine Loading Arms (2x liquid, 1x vapour, 1x dual/spare). Vapor return handled by the LNG FPSO. Liquefaction process provided by Black and Veatch will employ its PRICO[®] liquefaction technology with a capacity of about 0.6 MTPA per train.

The vessel data are: 294 m length, 62.6 m breadth, storage capacity 125,000 m³, 37,000 tons of new steel and equipment added, 8,900 tons of added steel works including new sponsons, topside and mooring structures, 9,000 tons of process equipment installed, 1,800 km of cables pulled onboard.³⁶

Gazprom, Perenco, and SNH (Société Nationale des Hydrocarbures) signed a firm eight-year sale and purchase contract for LNG from GoFLNG Hilli Episeyo. The first phase enabled Golar to drawdown up to USD 700 million from the facility to fund the ongoing conversion cost, once Golar has spent USD 400 million of the conversion cost and the tolling contract with Perenco and SNH have been ratified by the Cameroon government. The second phase started upon the delivery of the converted GoFLNG Hilli from Keppel Shipyard, allowing for the drawdown of up to a further USD 260 million. The financing has a tenor of 10-years, a 15-year amortization profile and contemplates the eventual sale of GoFLNG Hilli to Golar LNG Partners. The expected cost of the financing during the conversion period is 6.25 %, while the long-term financing is projected to cost less than 6% on a fully swapped ten-year basis³⁷.

³⁶ http://www.marinelog.com/index.php?option=com_k2&view=item&id=26513:flng-conversion-nears-completion&Itemid=257

³⁷ <http://worldmaritimeneews.com/archives/167100/golar-lng-bags-financing-for-goflng-hilli/>

This publication is produced under the auspices of the International Gas Union (IGU) which holds the copyright. The publication must not be reproduced in whole or in part without the written permission of the IGU. However, irrespective of the above, established journals or periodicals shall be permitted to reproduce this publication, or part of it, abbreviated or edited form, provided that credit is given to IGU. This document contains strictly technical information to be distributed during the 27th World Gas Conference in Washington DC, USA, and has no commercial intent.



The project in Cameroon is expected to have flexible tolling structure, which correlates to Brent crude oil prices ranging from a floor of 60 USD/bbl to a cap of 102 USD/bbl. The Tolling Agreement also includes a tariff for a 3rd train operation in case additional gas volumes can be processed or production advanced.

The benefits of the LNG FPSO Project for the State are, but not limited to, revenues via the sale of natural gas, revenues in the form of taxes, profit oil and gas, special contribution by the foreign actors to the local development fund and for the training of Cameroonian nationals as stipulated by the Gas Code; the production of 30,000 tons per year of LPG for the local market, which will reduce the importation need of this product and as a consequence reduce the required subvention, employment of Cameroonian nationals, and the involvement of local companies in during the construction, installation and exploitation of the LNG FPSO Vessel and corresponding extension of the Gas Processing Facility.

For SNH, which has a mandate to manage the State's interest in the oil and gas sector, the benefits for the State are by mandate benefits for SNH. The direct benefits for SNH include, but not limited to, the transfer of knowledge in LNG project to SNH's staff, added incentives for foreign investors to invest in the oil and gas sector in Cameroon, revenues for SNH as a stake holder in the upstream association, the creation of jobs via the LPG production, which requires the construction of LPG storage spheres and the management of this site. For Perenco the main benefit is revenues via the sale of natural gas in the form of LNG.

Golar Hilli represents an outstanding industry initiative bringing off-shore liquefaction solutions to monetize previously unexploited or marginal natural gas accumulations. Commercial innovations and optimisations in the upstream, mid-stream and downstream value chain have been decisive elements leading to the LNG FPSO's Project's FID. The completion of this unique project could trigger further perspectives for similar developments in the region." Golar's GoFLNG business model reduces the resource holder's CAPEX and project execution risk, advance their cash flow and is flexible enough to develop "small-size" reserves.

5.6 Conversion vs. New-built

Comparing differentiators between conversion and new-built LNG FPSO projects is one of the first steps to prepare a meaningful choice. This requires a good understanding of the risks and rewards of each alternative. Weighing the benefits of a proven hull, the costs of refurbishment and the schedule implications against a new-built hull is a complex optimization procedure. There are numerous other factors to be considered in the quest for an optimal solution. The weather conditions in the field need to be carefully considered as do the field, gas solutions, environmental concerns and the regulatory framework. LNG FPSOs projects are applying various development concepts, each of which offers certain advantages.

Small to mid-scale LNG FPSOs can be delivered quickly with lower cost than onshore plants. Consequently, despite low oil price and oversupplied LNG market, LNG FPSO projects will have a smaller parcel size based on the conversion or near shore barge concepts. The schedule could be reduced if speculative units are built on a standard design functional basis and become available as proposed by Golar LNG³⁸ and Exmar. The standard design approach by the leasing companies enables possible reuse, reducing the sunk cost risk on a specific project. The option to lease from the LNG FPSO solution providers further improves the cash flow and offers an advantage to the smaller independent gas companies who do not have the capital available to build the LNG FPSO vessel. Whilst this approach is common on FPSOs, it is a 'first' for the LNG liquefaction market.

	Conversions	New-Built
Ownership	offer leasing opportunities for smaller operators or for saving upfront investments	offer leasing opportunities for smaller operators or for saving upfront investments
Customizing	compromise some design choices by existing LNG carrier design	can be designed to specific field needs and for re-usability at another field
Life time	limited by existing hardware	will achieve long design lives
Capacity	will be based on standardized modules	can be designed to a wide range of liquefaction capacities
Cost, schedule	require less capital cost, shorter engineering and construction schedules,	higher CAPEX may offer lower total cost of ownership
Metocean conditions	more suitable for more benign environments	more adaptable for harsh environment as built on purpose
Power generation	gas turbines for cycle compressors, existing power sources for other consumers	gas turbines (steam turbines as an option only for larger capacities)
LNG storage	use of existing spherical tanks or type C tanks	reinforced membrane tanks in two rows with central bulkhead or SPB tanks

³⁸ <http://www.tradewindnews.com/gas/1215855/golar-lng-poised-to-tow-veteran-gandria-in-for-flng-conversion>

This publication is produced under the auspices of the International Gas Union (IGU) which holds the copyright. The publication must not be reproduced in whole or in part without the written permission of the IGU. However, irrespective of the above, established journals or periodicals shall be permitted to reproduce this publication, or part of it, abbreviated or edited form, provided that credit is given to IGU. This document contains strictly technical information to be distributed during the 27th World Gas Conference in Washington DC, USA, and has no commercial intent.

6 Conclusions, Challenges and Outlook

The LNG industry has over the last decades built up experience with floating LNG concepts, and there are many success stories but also examples with less positive feedback. There is no such thing as a typical floating LNG project and many projects are basically prototype and one-off developments.

This is not because of the technology itself, as LNG vaporisation processes for FSRUs, and liquefaction processes for LNG FPSOs are well-known and applied throughout the LNG industry, either onshore or offshore. There are challenges, such as the location of the development, countries' energy policies, regulations, environmental impacts, business model flexibility, financing, overall LNG market trends and general reliability about such a "new" concept that influence the development of a floating LNG project, maybe more than the technology aspect.

The FSRUs have experienced a high momentum in the recent years because of the flexibility they provide for having shorter time-to-market solutions (with respect onshore regasification terminals) which have been very useful for bridge supply solutions and for peak shaving solutions or baseload supply; especially for newcomers to the LNG consumption. On the other hand, the LNG FPSOs have somehow experienced a lesser success in the last years, following the trend in the LNG industry in which few liquefaction FIDs have been taken in a short-term scenario, with depressed gas prices and oversupply. However, in a different scenario, with recovered demand growth and higher price signals, this kind of solutions could gain momentum for example for developing small-mid size stranded gas resources.

One key element on the decision-making process for going to a floating solution is "new-built" vs "conversion from an existing carrier": in the FSRUs the two ways have largely been employed whilst for the LNG FPSOs, also influenced for the lack of momentum for the general concept, the conversion has not been widely adopted (although one of the study cases presented in this report is related to a converted LNG FPSO). In general terms, it can be said that a conversion may lead to shorten construction schedule while the new-built has more flexibility for accommodating to the specifics of the required production.

As part of this report the case studies have indicated that each and every floating LNG project was one of its-kind and faced different challenges in different manners. However, for FSRUs some standardisation pattern can be observed.

6.1 LNG FSRUs

The argued flexibility, relatively short construction period and low CAPEX of FSRUs have been key for decision makers to choose in favour of floating solutions for new LNG import terminals in some specific cases. When a solution is required to be in place within a relatively short time frame, the decision to install an FSRU gains momentum. Furthermore, after a detailed cost analysis the CAPEX of a floating terminal may be lower than an onshore solution for small to mid-size terminals mainly. However, long view commercial considerations may change decision maker's mind in favour of a standard onshore terminal.

As mentioned an important factor that should be considered is the total cost of the facility or CAPEX. Generally speaking a standard FSRU built by an expert South Korean yard might be convenient in terms of cost (comparing the LNG tanks construction and regasification plant installation on board to an onshore LNG terminal). Anyhow, for comparison purposes, the cost of jetties and other infrastructures have to be included, which makes the comparison exercise more complex. On the other hand, the payback period of an onshore terminal might be longer.

It can be concluded that maintenance or operation of a FSRU might be more complex than an onshore terminal. However, there has not been any issue linked to the operation of FSRUs provided detailed risk analysis and procedures have been developed and implemented. Although FSRUs are generally considered fast track projects that are easily developed, there are some specific challenges to be taken into consideration. Most commonly the challenges are related to the novelty of the concept which is not worldwide accepted beforehand and needs some preliminary considerations from local regulators.

In fact, uncertainty in connection with regulations to apply in general and in particular about the environmental requirements to comply with, might have a significant impact in the development of the FSRU facility in some specific cases. Despite of what was described in section 4.1 (LNG FSRU Drivers), in some projects environmental impact reports are positively sanctioned but only after a long period of negotiations and discussions depending on the location of the receiving terminal and national laws. In some other cases, national regulations just do not exist, therefore the process of authorisation might be more complicated as a result of the lack of guidelines to be followed.

In connection with the above, it is a fact that many of the new FSRU terminals commissioned or still under discussion are located in countries which did not have access to LNG imports before; therefore, lack of regulations may impact the project schedule or materialization.

Maintenance and inspection of an FSRU may not be easy or feasible for long term planned regasification facilities and in particular local or international regulations may impose dry docking the ship to perform a periodic inspection of the underwater parts. Disruption of the regasification activities in case of dry docking would last for weeks if not for few months depending on the location of the docking facility. The maintenance and required inspection of the tanks from inside,



in accordance with the international regulations may also impact the regasification operation unless a specific inspection program is put in place.

There are some technical aspects to consider that as well are linked to the safe operation of the units. Approximately a decade ago, when the first STS LNG transfer operations with flexible hoses took place at open sea, the method and technology was at the early stage of the development. Even today, these STS operations are considered non-conventional and even though no leaks during transfer have been recorded the proper risk assessment is to be carried out to get the authorization from the local authorities.

Conversion projects might lead to additional challenges. Some of them would have limited storage capacity as the units available in the market do not necessarily fit with the required current trends. Membrane containment systems might be not suitably designed for intermediate filling levels and subject to being damaged in case of sloshing. Further there is a need for more often inspection of a second-hand LNG carrier. Consequently, the necessary ship's modifications may lead to the fact that a conversion is not necessarily cheaper than a new-built. On the other hand, some modern concepts of small non-propelled barge type FSRU (or FRU) may be economically feasible CAPEX wise but more expensive in case of redeployment (need for towing) and a bit riskier, because of the need to add additional storage capacity alongside and related mooring and transfer issues between the FSU and FSRU. All the above potential issues may impact near shore or open sea FSRU projects. Anyhow, with reference to offshore FSRU projects, additional technical issues may occur for instance regarding mooring or station keeping which would make more difficult the LNG unloading operations or gas offloading.

Other commercial issues have to be considered as the FSRU model is slightly changing in the last years. Leasing or charter price for a 170,000 m³ FSRU may easily be over 100,000 USD/day for a 5 years contract making a bit less attractive the first business model originated in the middle of the 2000s. Gas importers and trading companies are taking steps progressively to own the FSRU as well, instead of time chartering the unit. This may lead to a completely new concept where for example national gas import companies order these types of units directly to the shipyard.

In connection with the above, commercial considerations have to be discussed in detail to decide about the business model and the type of terminal as cost comparison between an onshore terminal and an equivalent capacity FSRU is not a straight forward calculation and will depend on technical factors linked to location, regulations, weather conditions, or complexity of the terminal among others.

On the other hand, the flexibility of the FSRU ship concept to be also used as a trading ship might be put in risk as the LNG carrier market is currently under pressure due to the significant availability of ship and new deliveries to come. Anyhow, it is expected that the market will rebalance and charter rates for a modern LNG carrier rise.

6.2 LNG FPSOs

One of the main drivers for LNG FPSO was the cost inflation of large onshore LNG liquefaction facilities in at the end of 2000s beginning of 2010s. At that time this LNG FPSOs concept was a trending one in the agenda of many companies in the LNG industry (for infrastructures providers: shipping, EPC, technologists and for the Oil&gas Companies) as it might lead to optimized costs by itself (building in a shipyard) advantages but also potentially making economically viable turning small-medium size gas resources that were stranded if monetized by means of conventional “large” onshore liquefaction plants. However, as this trend now moved downwards among other reasons, because of the loose of momentum for new liquefaction projects, in general terms, few FID taken (onshore/offshore) in the years after that.

Some expectations were to unlock smaller fields, access remote fields, reduce environmental footprint, deliver projects faster, put projects in a safe pair of hands, achieve peace of mind from security worriers, mitigate political risk, access other financing options (the fact of a liquefaction on a ship provides with the possibility of accessing a time charter business model in which the shipowner makes the upfront investment and the “user” satisfies a fee)

Some of these reasons and or drivers now have changed to potential challenges.

- Unlocking smaller fields was a niche market, but nowadays bigger onshore fields are found and the requirement to unlock the smaller ones is economically less appealing.
- Access to remote fields was another reason for LNG FPSOs, but now this has become more of a challenge, since larger onshore discoveries allow easier access to gas.
- Reducing the environmental footprint and potentially relocating and re-deploying assets again at other fields poses the challenge that field compositions are drastically different and that the installed liquefaction technology and gas treating are not suitable requiring significant revamps of the LNG FPSO.
- Faster delivery of projects was certainly an advantage for those fields with long distances to shore, resulting in long subsea pipelines, slug catchers and significant dredging requirements. However, easier producible fields have been found and this advantage is becoming less of a benefit for floating liquefaction solutions.
- Putting projects in safe and controlled construction environment is a fair objective. Modular structures in shipyards with a controlled environment and workforce have always been an advantage over site construction where a dedicated workforce needs to be employed. However, more and more modular designs are used for onshore facilities, e.g. the process barge for Hammerfest LNG. So, the question is whether this previous advantage for floating remains.
- Security worries are not only an issue for onshore facilities, LNG carriers and floating liquefaction facilities can also suffer from piracy and open sea attacks. Therefore, this is not a true reason to elect floating developments over onshore developments.

- 
- Mitigating political risks is likewise challenging for onshore and offshore projects. As virtually all known gas fields belong to a certain country there is no no-man's-land without politics.
 - Financing of large LNG FPSOs is still not within reach for traditional lease companies. Beyond certain size/investment, it is challenging for shipowner companies to make all the upfront investment.

However, the near shore LNG FPSOs concept is a kind of LNG FPSOs which in general terms would be less challenging in terms of operations (usually on a harbour or moored in calm waters by sea shore) and in terms of investments (hull design, lack of required turret, and others) however it might be more limited in terms of the accessible gas resources (not suitable for open sea harsh conditions) that might more easily find out a niche in an LNG market framework in which much more additional LNG needs to be produced assuming the current trend of increasing oil prices.

In this sense, the last LNG FPSO in taking FID has been, precisely, a near shore LNG FPSO (converted) which shows that after a somehow “depressed” new liquefaction projects panorama in the recent years, with the new perspectives on the market the LNG FPSO's can have their niche.

In a nutshell, FLNG FPSOs may remain niche solutions for the near future with a sweet spot for standardised near shore applications of moderate size.

7 References and Acknowledgements

Key contributors to the report:

- Jorge Gómez de la Fuente, Leader (Repsol, Spain)
- Sander Lemmers, Sub-Leader (Vopak LNG, The Netherlands)
- Heinz Bauer (Linde Engineering, Germany)
- Carlos Guerrero (Bureau Veritas, France)

Team members:

- Yutasart Promban (PTT pcl., Thailand)
- Sanggyu Lee (Korea Gas Co., Korea)
- Jin Sang Park (Hyundai Heavy Industries, Korea)
- Patcharapa Chanthick (PTT pcl., Thailand)
- Kadda Bouchaala Reguiegue (HYPROC Shipping Co./Sonatrach, Algeria)
- Achille Nga Mvogo (Compagnie Nationale des Hydrocarbures, Cameroon)
- Shahrokh Zandieh Vakili (NIGC, Iran)
- Kiil Nam (Hyundai Heavy Industries, Korea)
- Houari Rayah (Sonatrach, Algeria)
- Mekahli Khadidja (HYPROC Shipping Co., Algeria) Khiter Abdelkader (Sonatrach, Algeria)

Bibliographic references of main used sources:

1. IGU Report 2017
2. Oxford Energy Institute
3. Platts
4. Cedigaz Medium and Long Term Natural Gas Outlook 2017
5. Poten & Partners “New LNG trading models and market conditions”
6. Timera Energy: “LNG glut: what’s happening?”, March 2017

8 Glossary of Terms

BOG = Boil-Off Gas
BOO = Build Own and Operate
CAPEX = Capital Expenditures
COMAH = Control of major accident hazards
SCV = Submerged Combustion Vaporiser
CCR = Central Control Room
CCS = Cargo Containment System
DCS = Distributed Control System
EPC = Engineering, Procurement and Construction
EPCC = Engineering, Procurement Construction and Commissioning
ESD = Emergency Shutdown System
EN = European Norm
FEED = Front-End Engineering and Design
FGS = Fire and Gas System
FID = Final Investment Decision
FOB = Free On Board
FSO = Floating storage and offloading facility
FPSO = Floating production, storage and offloading facility
FSRU = Floating Storage and Regasification Unit
FSU = Floating Storage Unit
FRU = Floating Regasification Unit
HAZOP = Hazard and Operability Study
HSE = Health Safety and Environment
IFV = Intermediate Fluid Vaporiser
IGC = International Gas Code
IMO = International Maritime Organisation
IMS = Integrated Management System
ISO = International Standardisation Organisation
ISPS = International Ship and Port Facility Security Code
JMB = Jetty Monitoring Building
LER = Local Equipment Room
LNG = Liquefied Natural Gas
LNG FPSO = Floating LNG production, storage and offloading
MARPOL = International Convention for the Prevention of Pollution from Ships
MARVS = Maximum allowable relief valve setting
MCR = Main Control Room
NFPA = National Fire Protection Association
NG = Natural Gas
NTS = National Transmission System (UK)

This publication is produced under the auspices of the International Gas Union (IGU) which holds the copyright. The publication must not be reproduced in whole or in part without the written permission of the IGU. However, irrespective of the above, established journals or periodicals shall be permitted to reproduce this publication, or part of it, abbreviated or edited form, provided that credit is given to IGU. This document contains strictly technical information to be distributed during the 27th World Gas Conference in Washington DC, USA, and has no commercial intent.



NO_x = Nitrogen Oxides
OPEX = Operating Expenditures
O&G = Oil & Gas
ORV = Open Rack Vaporiser
PMC = Project Management Consultant
QRH = Quick Release Hook
RINA = REGISTRO ITALIANO NAVALE
Seveso Directive= Technological Disaster Risk Reduction
SIGTTO = Society of International Gas Tanker and Terminal Operators
S&T = Shell and Tube
SOLAS = Save Our Lives At Sea
SO_x / SOX = Sulphur Oxides
STS = Ship to Ship

SPA = Sales and Purchase Agreement
USD = United States Dollars

MMSCFD = million cubic feet per day
MMBtu = million British thermal units
MTPA = million tonnes per annum
nm = nautical miles



27th WORLD GAS CONFERENCE
WASHINGTON DC

JUNE 25-29
2018



HOST ASSOCIATION



PROUDLY SUPPORTED BY

