



CODE OF PRACTICE - VOLUME TWO - TRAIN SYSTEM [CP2]		
TRANSADELAIDE INFRASTRUCTURE SERVICES		
PART 10: TRACK SUPPORT SYSTEMS		DOC. NO. CP-TS-960
Issue: 3	Date: 22/09/08	Page: 1 of 27

TRACK AND CIVIL INFRASTRUCTURE

CODE OF PRACTICE

VOLUME TWO - TRAIN SYSTEM [CP2]

TRACK SUPPORT SYSTEMS



CODE OF PRACTICE - VOLUME TWO - TRAIN SYSTEM [CP2] TRANSADELAIDE INFRASTRUCTURE SERVICES		
PART 10: TRACK SUPPORT SYSTEMS		DOC. NO. CP-TS-960
Issue: 3	Date: 22/09/08	Page: 2 of 27

TABLE OF CONTENTS

1.0	PURPOSE AND SCOPE	4
1.1	PURPOSE.....	4
1.2	PRINCIPLES.....	4
1.3	SCOPE	4
1.4	REFERENCES.....	4
2.0	TRACK CONFIGURATION DESIGN	6
2.1	TRACK SUPPORT SYSTEMS.....	6
2.2	AXLE LOADS AND SPEEDS	6
2.3	TRACK CONFIGURATIONS (BROAD GAUGE)	6
2.4	TRACK CONFIGURATIONS (MIXED GAUGE)	7
3.0	DESIGN OF SLEEPER FASTENING SYSTEMS, RAILS, SLEEPERS AND FASTENINGS	8
3.1	DESIGN OF SLEEPER FASTENING SYSTEMS FOR BROAD GAUGE TRACKS	8
3.2	DESIGN OF SLEEPER FASTENING SYSTEMS FOR MIXED GAUGE TRACKS	9
3.3	MANUFACTURE AND INSTALLATION OF RAILS, RAIL JOINTS AND RAIL ASSEMBLIES	9
3.4	MANUFACTURE AND INSTALLATION OF SLEEPERS AND FASTENINGS.....	10
3.5	TRANSITION BETWEEN DIFFERENT TRACK SUPPORT SYSTEMS	12
3.6	NON-CONFORMING CONFIGURATIONS	13
4.0	BALLAST	14
4.1	BALLAST MATERIAL.....	14
4.2	BALLAST PROFILE	14
5.0	ADELAIDE STATION CONCRETE SLAB TRACK.....	16
5.1	GENERAL.....	16
5.2	TRACK CONSTRUCTION	16
5.3	RAIL FASTENINGS	16
5.4	MONITORING THE CONCRETE SUB-STRUCTURE.....	16
5.5	MONITORING RAILS AND RAIL FASTENINGS.....	16
6.0	MONITORING AND MAINTENANCE OF SLEEPERS AND FASTENINGS	17
6.1	INSPECTION, ASSESSMENT AND MAINTENANCE ACTIONS	17
6.2	DEFINITION OF INEFFECTIVE SLEEPERS	17
6.3	INEFFECTIVE SLEEPERS – MAINTENANCE ACTION	18
6.4	MISSING SLEEPERS – MAINTENANCE ACTION	19
6.5	DIAGRAMS SHOWING RESPONSES TO SLEEPER CONDITION.....	20
7.0	MONITORING AND MAINTENANCE OF FORMATION AND BALLAST	22
7.1	INSPECTION, ASSESSMENT AND MAINTENANCE ACTIONS	22
7.2	FORMATION AND BALLAST DEFECTS AND CONDITIONS.....	22



CODE OF PRACTICE - VOLUME TWO - TRAIN SYSTEM [CP2] TRANSADELAIDE INFRASTRUCTURE SERVICES		
PART 10: TRACK SUPPORT SYSTEMS		DOC. NO. CP-TS-960
Issue: 3	Date: 22/09/08	Page: 3 of 27

7.3	BALLAST PROFILE DEFICIENCIES	23
7.4	PUMPING	25
7.5	UNCONSOLIDATED BALLAST	25
7.6	EXCESS BALLAST	26
8.0	DOCUMENTATION	27
8.1	TRACK CONFIGURATION RECORD	27
8.2	INSPECTION REPORTS	27



CODE OF PRACTICE - VOLUME TWO - TRAIN SYSTEM [CP2] TRANSADELAIDE INFRASTRUCTURE SERVICES		
PART 10: TRACK SUPPORT SYSTEMS		DOC. NO. CP-TS-960
Issue: 3	Date: 22/09/08	Page: 4 of 27

1.0 PURPOSE AND SCOPE

1.1 PURPOSE

The purpose of this part is to set standards to ensure that track support systems are safe and fit for purpose.

1.2 PRINCIPLES

This part complies with the principles set out in the “Code of Practice for the Defined Interstate Rail Network”, volume 4, part 2, sections 2 and 4.

1.3 SCOPE

This part specifies general procedures for the design/rating, construction, monitoring and maintenance of:

- a) Sleepers;
- b) Points & crossings bearers (timbers);
- c) plain track sleeper plates;
- d) points and crossings bearer plates;
- e) trackspikes i.e. dogspikes, spring fastening spikes and screw spikes;
- f) resilient rail clips;
- g) insulation pads and rail insulators;
- h) rail anchors; and
- i) formation and ballast.

This part provides for mixed gauge track as well as broad gauge and standard gauge tracks.

1.4 REFERENCES

1.4.1 Australian Standards

AS 1085.3 Railway permanent way material Part 3: Sleeper plates

AS 1085.8 Railway permanent way material Part 8: Dogspikes

AS 1085.9 Railway permanent way material Part 9: Rolled steel clip fastening sleeper plates

AS 1085.10 Railway permanent way material Part 10: Rail anchors

AS 1085.13 Railway permanent way material Part 13: Spring fastening spikes for sleeper plates

AS 1085.14 Railway permanent way material Part 14: Prestressed concrete sleepers

AS 1085.16 Railway permanent way material Part 16: Cast steel sleeper plates

AS 1085.17 Railway permanent way material Part 17: Steel sleepers

AS 2758.7 Aggregates and rock for engineering purposes Part 7: Railway ballast

AS 3818.1 Timber - Heavy structural products - Visually graded Part 1: General requirements

AS 3818.2 Timber - Heavy structural products - Visually graded Part 2: Railway track timbers



CODE OF PRACTICE - VOLUME TWO - TRAIN SYSTEM [CP2] TRANSADELAIDE INFRASTRUCTURE SERVICES		
PART 10: TRACK SUPPORT SYSTEMS		DOC. NO. CP-TS-960
Issue: 3	Date: 22/09/08	Page: 5 of 27

AS 4799 Installation of underground utility services and pipelines within railway boundaries

1.4.2 Industry codes of practice

- a) Code of Practice for the Defined Interstate Rail Network, volume 4 (Track, Civil and Electrical Infrastructure), part 2 (Infrastructure Principles), sections 2 (Sleepers and fastenings) and 4 (Ballast).

1.4.3 TransAdelaide documents

a) CP2

- CP-TS-952: Part 2, Structure and application
- CP-TS-953: Part 3, Infrastructure management and principles
- CP-TS-956: Part 6, Track geometry
- CP-TS-957: Part 7, Structures
- CP-TS-959: Part 9, Earthworks
- CP-TS-961: Part 11, Rails and rail joints
- CP-TS-962: Part 12, Guard/check rails, buffer stops and derails
- CP-TS-963: Part 13, Points and crossings
- CP-TS-964: Part 14, Rail stress control

b) TransAdelaide/Infrastructure Services Procedures

- QP-IS-501: Document and Data Control
- CPRD/PRC/046: Records Management

1.4.4 TransAdelaide drawings

- 304-A3-83-1650: Design standard: track anchor patterns for C.W.R.
- 304-A4-80-367: Design standard: spiking patterns on curves

Note: The following drawing is not referred to in this document but action needs to be taken as shown:

304-A3-83-917: Design standard: ballast cross-sections

TO BE REVISED IN ACCORDANCE WITH INCREASED BALLAST DEPTH VIDE TABLE 3.1



CODE OF PRACTICE - VOLUME TWO - TRAIN SYSTEM [CP2] TRANSADELAIDE INFRASTRUCTURE SERVICES		
PART 10: TRACK SUPPORT SYSTEMS		DOC. NO. CP-TS-960
Issue: 3	Date: 22/09/08	Page: 6 of 27

2.0 TRACK CONFIGURATION DESIGN

2.1 TRACK SUPPORT SYSTEMS

- a) This section describes the various track configuration systems for broad gauge, standard gauge and mixed gauge track.
- b) Components used on TransAdelaide ballasted rail tracks are described in section 3.0.
- c) Formation and ballast are described in section 4.0.
- d) Concrete slab track used in Adelaide Railway Station is described in section 5.0.

2.2 AXLE LOADS AND SPEEDS

Rail tracks shall be designed for the axle loads and speeds shown in CP-TS-952 (Structure and application).

2.3 TRACK CONFIGURATIONS (BROAD GAUGE)

The track configurations to be used on TransAdelaide broad gauge rail tracks shall comply with table 2.1, except where rail lengths are varied to suit the position of insulated joints or are subject to other influences:

Table 2.1: Track configurations for broad gauge tracks

Rail type		Length of rails	Sleepers	Joints	Fastening system	For fastening systems refer to table 3.1, line:-
1	Jointed and short welded rail (S.W.R.)	12-35m	Timber	Square	Trackspikes	1
			Timber	Square	Resilient fastenings	2
			Timber	Staggered	Resilient fastenings	2
			Steel	Staggered	Resilient fastenings	3
2	Long welded rail (L.W.R.)	35-75m	Timber	Square	Trackspikes	1
			Timber	Square	Resilient fastenings	2
			Steel	Square [see note 1]	Resilient fastenings	3
3	Continuously Welded Rail (CWR)	> 75m	Timber	Nil	Trackspikes	1
			Timber	Nil	Resilient fastenings	2
			Steel note [2]	Nil	Resilient fastenings	3
			Concrete [see notes 2 and 3]	Nil	Resilient fastenings	4

Notes:

- [1] On curves of less than 400m radius, welded rails 35 to 75m in length on steel sleepers shall be laid with staggered joints.
- [2] Continuously welded rail laid on concrete or steel sleepers is the preferred configuration for new work on tangents or curves > 1 000m radius;



CODE OF PRACTICE - VOLUME TWO - TRAIN SYSTEM [CP2] TRANSADELAIDE INFRASTRUCTURE SERVICES		
PART 10: TRACK SUPPORT SYSTEMS		DOC. NO. CP-TS-960
Issue: 3	Date: 22/09/08	Page: 7 of 27

[3] Continuously welded rail laid on concrete sleepers is the preferred configuration for new work on curves $\leq 1\ 000\text{m}$ radius.

2.4 TRACK CONFIGURATIONS (MIXED GAUGE)

The track configurations to be used on TransAdelaide mixed gauge rail tracks shall comply with table 2.2, except where rail lengths are varied to suit the position of insulated joints or are subject to other influences:

Table 2.2: Track configurations for mixed gauge tracks (see also note [1])

	Rail Type [see note 2]			Sleepers	Joints	Fastening system
	Common rail	Standard gauge rail	Broad gauge rail			
1	L.W.R	L.W.R.	S.W.R.	Timber	Staggered	Trackspikes
2	C.W.R.	S.W.R.	C.W.R.	Timber	In one rail only	Trackspikes
3	S.W.R.	S.W.R	S.W.R.	Timber	Staggered	Trackspikes
4	C.W.R.	C.W.R.	C.W.R.	Concrete	None	Resilient fastenings

Notes:

- [1] Continuously welded rail laid on concrete sleepers is the preferred configuration for new work on all mixed gauge track;
- [2] S.W.R. = Jointed or short welded rail; length of rails 12m-35m;
L.W.R. = Long welded rail; length of rails 35m-75m;
C.W.R. = Continuously welded rail: length of rails > 75m.



CODE OF PRACTICE - VOLUME TWO - TRAIN SYSTEM [CP2] TRANSADELAIDE INFRASTRUCTURE SERVICES		
PART 10: TRACK SUPPORT SYSTEMS		DOC. NO. CP-TS-960
Issue: 3	Date: 22/09/08	Page: 8 of 27

3.0 DESIGN OF SLEEPER FASTENING SYSTEMS, RAILS, SLEEPERS AND FASTENINGS

3.1 DESIGN OF SLEEPER FASTENING SYSTEMS FOR BROAD GAUGE TRACKS

For broad gauge tracks, the sleeper fastenings and fittings for the various track configurations shall comprise compatible individual components in accordance with table 3.1:

Table 3.1: Fastening systems for broad gauge tracks

General track system configuration	Fastening components	No. per sleeper	Refer to table 3.7; line:
1. Timber sleepers & bearers with trackspikes and rail anchors [see note 1 & 6]	Sleeper plates	2 no.	1
	Trackspikes	[see note 2]	2,3 or 4
	Rail anchors	[see note 3]	10
2. Timber sleepers & bearers with spring fastening spikes or screw spikes (plate fixing); resilient fastenings (rail fixing)	Sleeper plates	2 no.	1
	Spring fastening spikes	4 No.	2
	Lock-in shoulders ("F & G"s)	[see note 4]	5
	Resilient rail clips	4 No.	6
3. Steel sleepers & bearers with resilient fastenings [see note 5]	Lock-in shoulders	[see note 4]	5
	Resilient rail clips	4 No.	6
	Insulated pads	2 No.	7
	Rail insulators ("biscuits")	4 No.	8
4. Concrete sleepers & bearers with resilient Fastenings	Lock-in shoulders	[see note 4]	5
	Resilient rail clips	4 No.	6
	Rail insulators ("biscuits")	4 No.	8
	Rail pads	2 No.	7

Notes:

- [1] Sleepers using resilient rail clips i.e. "F and G"s are not to be randomly mixed with sleepers using trackspikes and rail anchors but must strictly only be used on a face or substituted for box anchored sleepers (as defined in note 3).
- [2] Normally 4 no. but the number of dogspikes or spring fastening spikes may be varied in accordance with drg 304-A4-80-367.
- [3] Timber sleepers only - The minimum number of anchors used on CWR shall be in accordance with drg 304-A3-83-1650. On other configurations (i.e. where rail lengths are 75m or less) the following rule shall apply to the minimum number of anchors required:
 - a) Determine the number of sleepers per rail length;
 - b) Divide the number of sleepers by 4;
 - c) Round up this figure to the next highest even number;
 - d) This answer shall then be the number of sleepers to be box anchored (half one side and half the other side of the joint) on each alternate sleeper, starting with the second sleeper from the joint.



CODE OF PRACTICE - VOLUME TWO - TRAIN SYSTEM [CP2] TRANSADELAIDE INFRASTRUCTURE SERVICES		
PART 10: TRACK SUPPORT SYSTEMS		DOC. NO. CP-TS-960
Issue: 3	Date: 22/09/08	Page: 9 of 27

EXAMPLE:

- a) If the rail lengths are 12m, the number of sleepers = 18 No.
 - b) Divide by 4 = 4.5.
 - c) Round up to next even number = 6 No. (i.e. 3 No. each side of the joint).
 - d) Therefore: box anchor the 2nd, 4th and 6th sleeper each side of every joint.
- [4] Lock-in shoulders are to be used with proprietary resilient rail clips as required, i.e. the number of lock-in shoulders shall be the same number as the resilient rail clips when used.
- [5] On tangent track, steel sleepers shall only be interspersed 1 in 4 or 1 in 2 between timber sleepers. Otherwise steel sleepers must be laid on a face including on any curve
- [6] Concrete sleepers shall be laid on a face
- [7] Pinus Radiata (creosote) sleepers may remain in track as a non conforming configuration but are not permitted in curves less than 1000mR and must be spiked in accordance with drawing 304-A4-80-367.

3.2 DESIGN OF SLEEPER FASTENING SYSTEMS FOR MIXED GAUGE TRACKS

For mixed gauge track, the sleeper fastenings and fittings for the various track configurations shall comprise compatible individual components in accordance with table 3.2:

Table 3.2: Fastening systems for mixed gauge tracks

General track system configuration	Fastening components	No. per sleeper	Refer to table 3.7; line:
1. Timber sleepers & bearers with trackspikes and rail Anchors	Sleeper plates	2 no.	1
	Trackspikes	[see note 1]	2,3 or 4
	Rail anchors	[see note 2]	10
2. Concrete sleepers & bearers with resilient fastenings	Lock-in shoulders	[see note 3]	5
	Resilient rail clips	5 No.	6
	Rail insulators ("biscuits")	6 No.	8
	Rail pads	3 No.	7

Notes:

- [1] Normally 6 no. but the number of dogspikes may be varied in accordance with drg 304-A4-80-367.
- [2] Timber sleepers only - The minimum number of anchors used on CWR shall be in accordance with drg 304-A3-83-1650. On other configurations (i.e. where rail lengths are 75m or less) see note [3] of table 3.1
- [3] Lock-in shoulders are to be used with proprietary resilient rail clips as required, i.e. the number of lock-in shoulders shall be the same number as the resilient rail clips when used.

3.3 MANUFACTURE AND INSTALLATION OF RAILS, RAIL JOINTS AND RAIL ASSEMBLIES

3.3.1 Rails, rail joints and rail assemblies

For details of:



CODE OF PRACTICE - VOLUME TWO - TRAIN SYSTEM [CP2] TRANSADELAIDE INFRASTRUCTURE SERVICES		
PART 10: TRACK SUPPORT SYSTEMS		DOC. NO. CP-TS-960
Issue: 3	Date: 22/09/08	Page: 10 of 27

- a) rail and rail joints refer to CP-TS-961(Rails and rail joints);
- b) rail assemblies for points and crossings refer to CP-TS-963 (Points and crossings);

3.3.2 Rail cant (inclination)

Rails in plain track shall preferably be laid with an inward 1 in 20 cant (inclination). Rails may also be laid standing vertically e.g. in concrete slab track where the rail is encased or in points and crossings.

Transition between vertical and inclined rail shall take place over seven sleepers with the rotation of the rail progressing as shown in Table 3.3. The transition shall desirably occur 10 sleepers away from the toe of switch and the last long bearer of the turnout or the edge of the slab.

Table 3.3: Transition of rail cant (inclination)

Sleeper No.	Rail Cant
Sleeper 0	Vertical rail
Sleepers 1 and 2	inclined 1 in 80
Sleepers 3 and 4	inclined 1 in 40
Sleepers 5 and 6	inclined 1 in 30
Sleeper 7	Inclined 1 in 20 (normal rail cant)

Where additional turnouts, diamonds or other sections of track requiring vertical rail exist within 100m then consideration shall be given to maintaining vertical rail through the full length to reduce the number of rail inclination transitions. The extent of vertical rail shall be shown on the drawings where this occurs.

The transition sleepers shall be marked with rail inclination.

Rail section changes shall not take place within the areas of rail inclination change. Rail inclination change shall not coincide with transition curves.

Figure 3.1 presents the requirements for rail cant (inclination) transition graphically.

3.4 MANUFACTURE AND INSTALLATION OF SLEEPERS AND FASTENINGS

Tables 3.4, 3.5, 3.6 and 3.7 prescribe for each type of sleeper, the requirements for its manufacture, materials and material testing, design or specification, component testing, compliance and installation:

Table 3.4: Component manufacture and installation – all sleepers

Sleeper type	Manufacture shall comply with the requirements of:	Nominal sleeper sizes
1. Timber (see note 1)	AS 3818.1 & AS 3818.2	260 x 130 x 2 600
2. Steel	AS 1085.17	
3. Concrete (see note 2)	AS 1085.14 [see also note]	

Note 1: Timber sleepers shall be fitted with end plates

Note 2: Concrete sleepers for mixed gauge track or for special uses shall be manufactured in accordance with the drawings shown in table 3.5:



CODE OF PRACTICE - VOLUME TWO - TRAIN SYSTEM [CP2] TRANSADELAIDE INFRASTRUCTURE SERVICES		
PART 10: TRACK SUPPORT SYSTEMS		DOC. NO. CP-TS-960
Issue: 3	Date: 22/09/08	Page: 11 of 27

Table 3.5: Component manufacture and installation – special concrete sleepers

Drawing No.	Title
327.A3.03.040	Broad Gauge Sleeper with Check Rails Design Spec. SLD 225-22
327.A3.03.041	Pedestrian Gauge Convertible Sleeper (Broad/Standard)
327.A3.03.042	Gauge Convertible Sleeper (Broad/Standard) Design Spec. SLD 225-22

Table 3.6: Sleeper spacing (in mm)

Sleeper Type	Current	Spot re-Sleepering	Reconstruction and New works				Points & crossings
			Plain track	IRJs	Level crossings	Pedestrian crossings [see note]	
1. Timber	760	as existing	670	See note 4	600	See note 1	As per bearer & timbering diagrams
2. Steel	760	as existing	670		N/A		
3. Concrete	670	as existing	670		600		

Notes for table 3.6:

- [1] Spacing for pedestrian crossings shall be determined in accordance with pedestrian crossing type design.
- [2] Tolerance on sleeper spacing for new works shall be +/- 10mm, minimum 1493 sleepers per kilometer.
- [3] Tolerance on sleeper skew for new works shall be +/- 10mm measured at gauge face
- [4] Sleeper spacing at IRJs reduced to 600mm for concrete sleepers and 515mm for other sleeper types to provide support to joint. Refer to CP - TS - 961 clause 7.4.5

Table 3.7: Component manufacture and installation - fastenings and fittings

Component	Manufacture shall comply with the requirements of:	Installation shall be in accordance with
1. Sleeper plates see notes [1] to [4]	AS 1085.3, AS 1085.9 or AS 1085.16 as applicable to type of system used	See note [5]
2. Spring fastening spikes	AS 1085.13	See note [5] or drg. 304-A4-80-367 (for curved track only)
3. Screw spikes	See note [2]	See note [5] or drg. 304-A4-80-367 (for curved track only)
4. Dogspikes	AS 1085.8	See note [5] or drg. 304-A4-80-367 (for curved track only)
5. Lock-in shoulders	See note [2]	See note [5]
6. Resilient rail clips	AS 1085.14 (concrete) or AS 1085.17 (steel), for timber see note [2]	See note [5]
7. Rail/Insulation pads	See note [2]	See note [5]



CODE OF PRACTICE - VOLUME TWO - TRAIN SYSTEM [CP2] TRANSADELAIDE INFRASTRUCTURE SERVICES		
PART 10: TRACK SUPPORT SYSTEMS		DOC. NO. CP-TS-960
Issue: 3	Date: 22/09/08	Page: 12 of 27

8. Rail insulators (“biscuits”)	See note [2]	See note [5]
9. Rail spacers	See note [2]	See note [5]
10. Rail anchors	AS 1085.10	See table 3.1, notes [2] and [3]

Notes:

- [1] Sleeper plates shall include the following:
 - a) Sleeper plates with a nominal rail cant of 1 in 20 towards the centre of the track or level plates for use in turnouts and some level crossings.
 - b) Sleeper plates for use with dogspikes, spring fastening spikes or screw spikes.
- [2] Sleeper plates shall be used for all timber re-sleepering.
- [3] In points and crossings, acceptable fittings include strap plates and crossing plates for use with resilient rail fastenings.
- [4] For mixed gauge track on timber sleepers, special sleeper plates to drawing no. xxx xx xx xxxx shall be used under the dual rail side.
- [5] Acceptable proprietary fittings are to be manufactured and installed in accordance with drawings and specifications approved by TransAdelaide and supplied by the manufacturer or his agent.

3.5 TRANSITION BETWEEN DIFFERENT TRACK SUPPORT SYSTEMS

3.5.1 Stiffness transitions

At locations where the track support system changes, such as on the approach embedded rail level crossings, the design shall provide for a controlled change in stiffness of the track. This controlled change in stiffness shall be provided by a reduction in sleeper spacing in conjunction with increased stiffness of the capping layer.

Transition in sleeper spacing shall be provided in accordance with section 3.5.2.

Track stiffness transition shall be provided as detailed in table 3.8.

Table 3.8 Track Stiffness transition requirements

Transition Type	Transition Length [1]	Length / Material / Depth	Sleeper spacing	Other Transition Requirements
Ballast deck bridge	5m [2]	Normal	600mm	Approach slab [2]
Embedded rail	20m	10m /Capping/ 300mm	670mm	
		10m /3% CTCR [4]/ 200mm over Capping/ 200mm	600mm	

Notes for table 3.8

- [1] Transition for this length at each interface to and from open ballasted track.
- [2] Transition to ballast deck bridges is achieved through approach slabs. Approach slab length may vary to suit the design. Refer Part 4 Structures for further details
- [3] Table 3.8 assumes adjacent ballasted track has 150mm minimum thickness capping layer.



CODE OF PRACTICE - VOLUME TWO - TRAIN SYSTEM [CP2] TRANSADELAIDE INFRASTRUCTURE SERVICES		
PART 10: TRACK SUPPORT SYSTEMS		DOC. NO. CP-TS-960
Issue: 3	Date: 22/09/08	Page: 13 of 27

[4] 3% CTCR – as per DTEI Specification for SIDNoBinder3 using PM2/30 base material

3.5.2 Sleeper Transition

Where a transition occurs between a timber sleepers section of track and a concrete sleepers section, a minimum of 10 new 150 mm deep timber sleepers spaced at 600 mm with resilient fastenings shall be used adjacent to the concrete sleepers.

There shall be no transitions allowed from concrete sleepers to steel sleepers.

Sleeper transitions shall not be located over a curve, including transitions, bridge approaches and level crossings. Preferably sleeper transitions should be at least 10 m from a curve, bridge approaches and level crossings.

No rail section change may occur within sleeper transition zones.

3.6 NON-CONFORMING CONFIGURATIONS

Although this part prescribes standard track support configurations and components to be used on TransAdelaide tracks, where it is necessary to deviate from these prescribed standards, the suitability of the non-conforming configurations or components shall be analyzed in accordance with CP-TS-953 (Infrastructure management and principles).



CODE OF PRACTICE - VOLUME TWO - TRAIN SYSTEM [CP2] TRANSADELAIDE INFRASTRUCTURE SERVICES		
PART 10: TRACK SUPPORT SYSTEMS		DOC. NO. CP-TS-960
Issue: 3	Date: 22/09/08	Page: 14 of 27

4.0 BALLAST

4.1 BALLAST MATERIAL

The manufacture, materials and material testing, design or specification, testing and compliance of ballast shall comply with the requirements of AS 2758.7.

All ballast for new mainline work shall be Class N 60mm nominal size.

Ballast for renewal work where steel sleepers are to be maintained shall be Class N, 60mm Steel Sleeper grading.

Rock types and source shall be approved prior to ordering.

4.2 BALLAST PROFILE

Ballast profiles shall be installed and ultimately finished in accordance with table 4.1 and figure 4.1:

Table 4.1: Ballast profiles

Sleeper type	Minimum ballast depth from sleeper soffit [see note 1]	Maximum shoulder slope	Sleeper spacing	Minimum ballast shoulder width from sleeper end [see note 2]
Timber	250mm	1 in 1.5	760mm	400mm
			670mm	350mm
Steel	250mm	1 in 1.5	760mm	350mm
			670mm	300mm
Concrete	250mm	1 in 1.5	670mm	300mm

Notes for table 4.1 and figure 4.1 on next page:

- [1] The depth of ballast is measured vertically under the rail seat.
- [2] The shoulder width specified for steel sleepers is measured from the extreme end of the sleeper, not the visible end when the track is fully ballasted.

CODE OF PRACTICE - VOLUME TWO - TRAIN SYSTEM [CP2] TRANSADELAIDE INFRASTRUCTURE SERVICES	
PART 10: TRACK SUPPORT SYSTEMS	DOC. NO. CP-TS-960
Issue: 3	Date: 22/09/08 Page: 15 of 27

**Figure 4.1: Ballast profile for double track
CROSS-SECTION THROUGH TRACK**

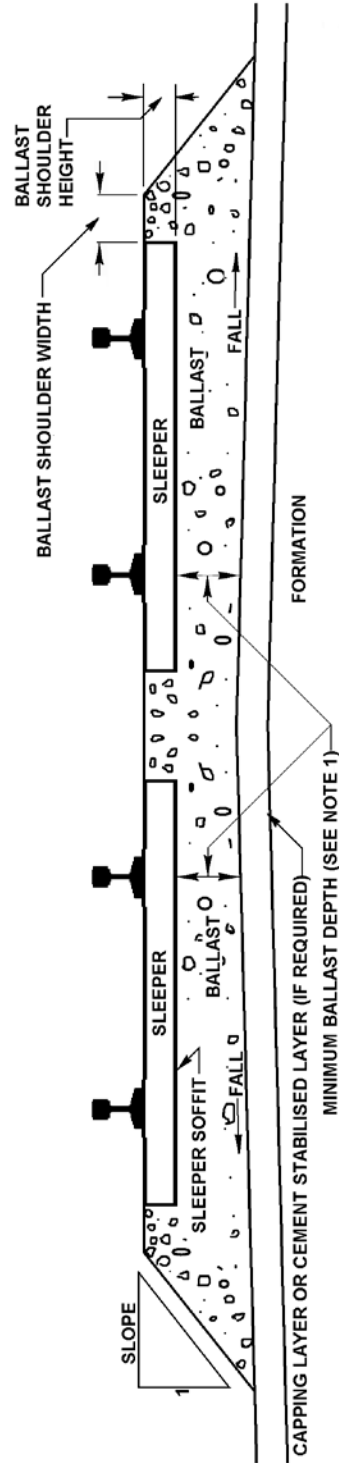

CROSS-SECTION OF DRAIN IN CESS IN CUTTING

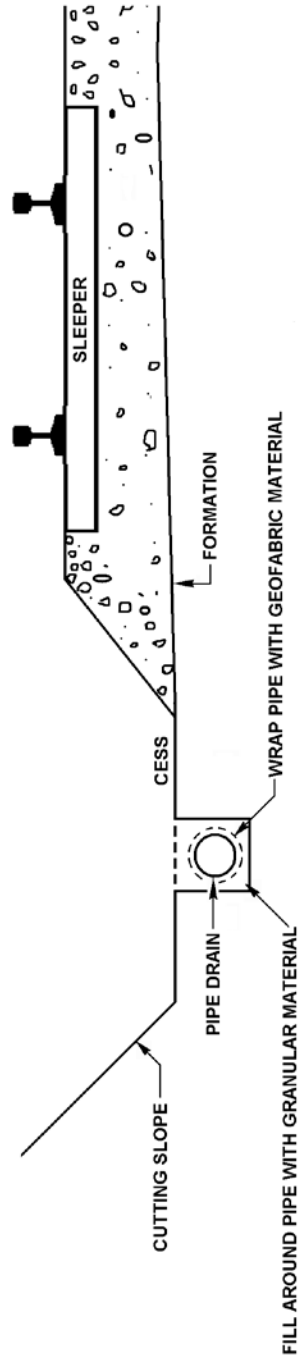

CODE OF PRACTICE - VOLUME TWO - TRAIN SYSTEM [CP2]		
TRANSADELAIDE INFRASTRUCTURE SERVICES		
PART 10: TRACK SUPPORT SYSTEMS	DOC. NO. CP-TS-960	
Issue: 3	Date: 22/09/08	Page: 16 of 27

5.0 ADELAIDE STATION CONCRETE SLAB TRACK

5.1 GENERAL

The nine platform tracks in Adelaide Railway Station partly use a non-standard form of track construction, which is designed to reduce the transmission of vibrations into the buildings above. These vibrations are generated by trains entering the platforms.

5.2 TRACK CONSTRUCTION

The track construction consists of precast concrete slabs supported on an in-situ concrete foundation. Neoprene pads are used between the foundation and the "floating" slabs as shown in figure 5.1:

Figure 5.1: Slab track construction

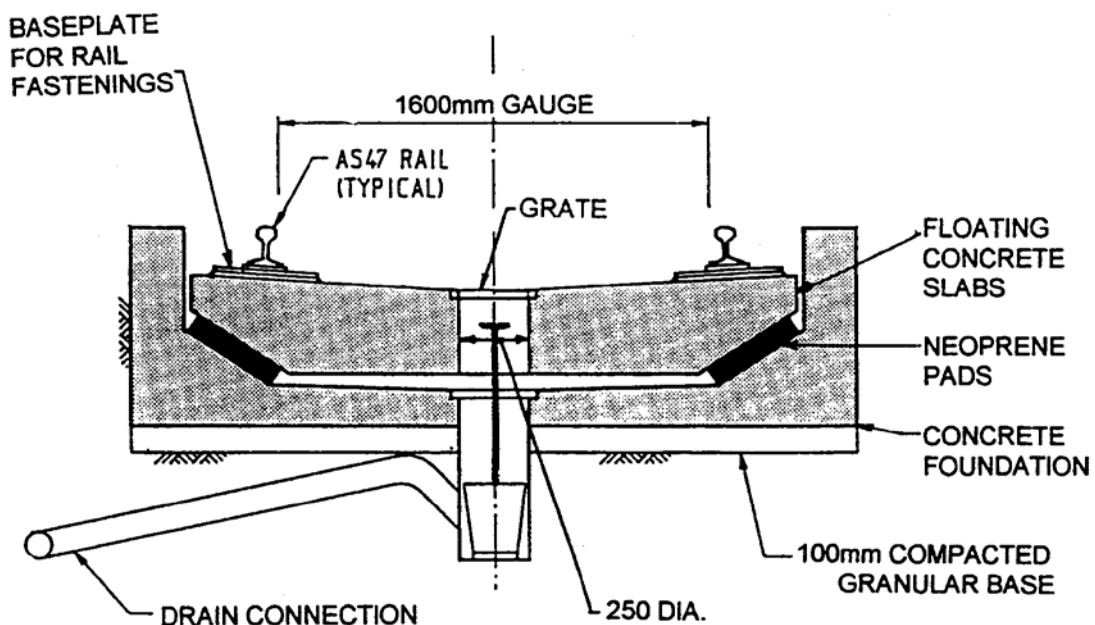

5.3 RAIL FASTENINGS

The rails are supported on flat sleeper plates and held in place with Pandrol clips.

5.4 MONITORING THE CONCRETE SUB-STRUCTURE

The concrete sub-structure is to be considered as a structure and shall be monitored in accordance with CP-TS-957 (Structures).

5.5 MONITORING RAILS AND RAIL FASTENINGS

Rail and rail joints shall be monitored in accordance with CP-TS-961 (Rails and rail joints). Rail fastenings shall be monitored in accordance with this part.



CODE OF PRACTICE - VOLUME TWO - TRAIN SYSTEM [CP2] TRANSADELAIDE INFRASTRUCTURE SERVICES		
PART 10: TRACK SUPPORT SYSTEMS		DOC. NO. CP-TS-960
Issue: 3	Date: 22/09/08	Page: 17 of 27

6.0 MONITORING AND MAINTENANCE OF SLEEPERS AND FASTENINGS

6.1 INSPECTION, ASSESSMENT AND MAINTENANCE ACTIONS

This section prescribes the requirements for inspection and response to sleeper and fastening assembly conditions. For the purposes of this section, “sleepers” shall include the following.

- a) Sleepers designed and manufactured from timber, steel or concrete in accordance with section 3.0;
- b) Points and crossing bearers. Refer to CP-TS-963 (Points and crossings) for bearers in critical areas of points and crossings; and
- c) Bridge timbers.

Fastening assembly condition for guard rails and continuous check rails [see CP-TS-962 (Guard/check rails, buffer stops and derails)] should be assessed in accordance with this section.

On mixed gauge track, where any degradation in one gauge requires different maintenance action to that required on the other gauge, any restrictions or responses shall be as for the worst case.

Table 6.1: Inspection of sleepers and fastening systems

Type of inspection	Specific actions or conditions to observe
Scheduled inspections	
Walking inspections	<ol style="list-style-type: none"> a) Identify visually, and report, obvious sleeper and fastening conditions which indicate degradation. b) Intervals between walking inspections shall not exceed 31 days.
General inspections	<ol style="list-style-type: none"> a) Ineffective sleepers as defined in sub-section 6.2 shall be identified and the number of ineffective sleepers per half kilometre reported. b) To be carried out visually in a manner and at an interval appropriate to the sleeper and fastening type, condition, rates of deterioration and other local and seasonal factors, however shall be at intervals not greater than 1 year for timber sleepers track or 2 years for concrete and steel sleepers track
Detailed inspections	An inspection of a particular component for a specific defect arising from the walking or general inspection, e.g. length of cracks in steel or concrete sleepers and shall include reporting and marking of sleepers as appropriate.
Unscheduled inspections	To be undertaken following a defined event affecting the track or a report from a TransAdelaide worker, Traffic Operator or a member of the public.
Assessment and method of assessment	The assessment of sleeper and fastening assembly condition and response criteria shall be in accordance with sub-sections 6.3, 6.4 and 6.5. Sub-section 6.5 shows the assessments in diagram form.

6.2 DEFINITION OF INEFFECTIVE SLEEPERS

This sub-section defines the meaning of “ineffective sleepers”, “ineffective bearers” and “ineffective bridge timbers.” These assessments and responses relate primarily but not exclusively to timber sleepers.



CODE OF PRACTICE - VOLUME TWO - TRAIN SYSTEM [CP2] TRANSADELAIDE INFRASTRUCTURE SERVICES		
PART 10: TRACK SUPPORT SYSTEMS		DOC. NO. CP-TS-960
Issue: 3	Date: 22/09/08	Page: 19 of 27

- [2] If two clusters of consecutive ineffective sleepers or fastening assemblies are not separated by a cluster of at least an equal number of consecutive effective sleepers and fastening assemblies, the effective sleepers shall be considered to be ineffective (eg. 3 ineffective followed by 2 effective followed by 2 ineffective shall be considered as one cluster of 7 ineffective, whilst 3 ineffective followed by 3 effective followed by 2 ineffective shall be considered as one cluster of 3 ineffective as the worst case).

6.4 MISSING SLEEPERS – MAINTENANCE ACTION

The actions proposed in this sub-section are based on the sleeper spacing being in accordance with table 3.2 under “current.” For conditions on sleeper maintenance activities, particularly re-sleeping on a face, refer to CPTS-964 Part 14 Rail Stress Control, Section 6.

The maximum permissible speeds for consecutive missing sleepers in an isolated location i.e. all gauge holding and bearing lost are shown in table 6.3:

Table 6.3: Maximum permissible speed responses at isolated locations

No. of consecutive missing sleepers	Action to be taken
1 [see notes 1 and 2]	No action
2 [see note 1]	Pilot or repair
>2 [see note 1]	Stop all train movements or immediate repair

Notes on table 6.3:

- [1] Missing sleepers do not include sleepers removed during re-sleeping except as described in notes [3] and [4]
- [2] If two clusters of missing sleepers are not separated by a cluster of sleepers with at least an equal number plus one of consecutive effective sleepers and fastening assemblies then the effective sleepers shall be considered to be missing (eg. 2 missing followed by 2 effective followed by 2 missing shall be considered as one cluster of 6 missing, whilst 2 missing followed by 3 effective followed by 1 missing shall be considered as one cluster of 2 missing as the worst case).
- [3] For re-sleeping on a face only. Alternate single sleepers may be removed from the track while resleeping under traffic, provided:
- i) a speed restriction of 20km/h for passenger trains and 15km/h for freight trains is imposed while sleepers are out of the track;
 - ii) the gang is present for all train movements and track maintenance workers inspect the track for safety after each train movement; and
 - iii) the track is fully restored before the gang leaves the site.
- [4] For spot re-sleeping only. Up to two adjacent sleepers may be removed under traffic at a time provided no other sleepers are out of track. A speed limit of 20km/h is to apply. The gang must be present for all train movements.
- [5] The criteria in CP-TS-956 (Track geometry) also apply, i.e. where missing sleepers or fastening assemblies result in track geometry irregularities.

CODE OF PRACTICE - VOLUME TWO - TRAIN SYSTEM [CP2] TRANSADELAIDE INFRASTRUCTURE SERVICES		
PART 10: TRACK SUPPORT SYSTEMS		DOC. NO. CP-TS-960
Issue: 3	Date: 22/09/08	Page: 20 of 27

6.5 DIAGRAMS SHOWING RESPONSES TO SLEEPER CONDITION

Diagram 6.1: Responses to ineffective sleepers (see table 6.2)

a) One sleeper ineffective, minimum of one effective sleeper either side

RESPONSE = No action

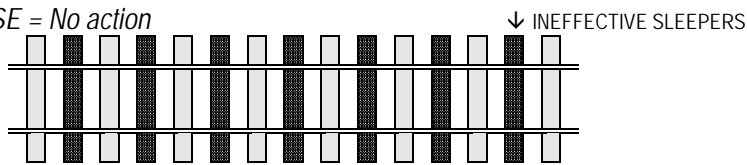

b) Two sleepers ineffective, minimum of two effective sleepers either side

RESPONSE = No action

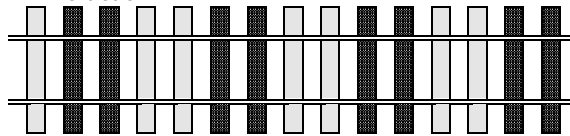

c) Three sleepers ineffective, minimum of three effective sleepers either side

RESPONSE = Impose a 50km/h speed limit or immediate repair

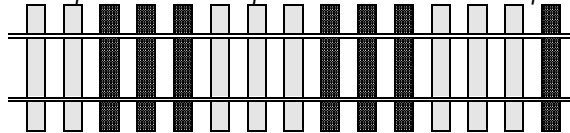

d) Four sleepers ineffective, minimum of four effective sleepers either side

*RESPONSE = Impose a 30km/h speed limit on tangent track or
20km/h on 600m radius curves or less; or immediate repair*

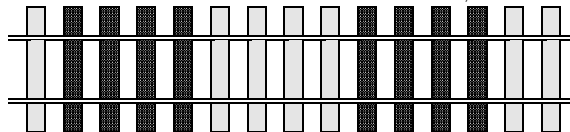

e) More than four sleepers ineffective

RESPONSE = Impose a 10km/h speed limit with piloting; or immediate repair

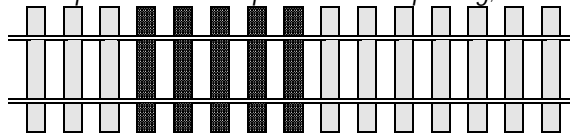
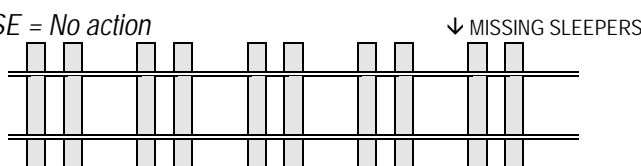

Diagram 6.2: Responses to missing sleepers (see table 6.3)

a) One sleeper missing, minimum of two effective sleepers either side

RESPONSE = No action





CODE OF PRACTICE - VOLUME TWO - TRAIN SYSTEM [CP2] TRANSADELAIDE INFRASTRUCTURE SERVICES		
PART 10: TRACK SUPPORT SYSTEMS		DOC. NO. CP-TS-960
Issue: 3	Date: 22/09/08	Page: 21 of 27

b) Two sleepers missing, minimum of three effective sleepers either side

RESPONSE = Impose a 10km/h speed limit with piloting; or immediate repair

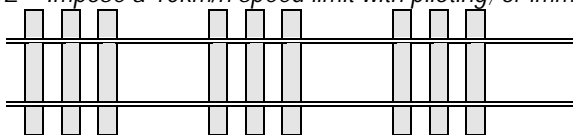

c) If conditions are worse than in (b), *RESPONSE = Stop all train movements or immediate repair*

Diagram 6.3: Permissible sleepers removed for re-sleeping (see table 6.3)

a) For spot resleeping, two adjacent sleepers may be removed together if no other sleepers are out of track

RESPONSE = Impose a 20km/h speed limit; gang to be present for all train movements

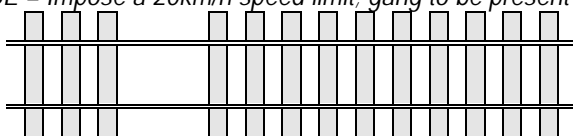

b) For resleeping on a face, for each sleeper taken out there shall be one effective sleeper either side

RESPONSE = Impose a 20km/h speed limit while work in progress

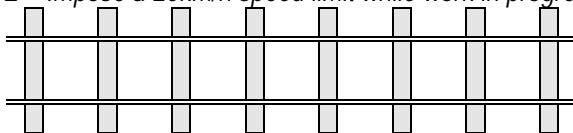



CODE OF PRACTICE - VOLUME TWO - TRAIN SYSTEM [CP2] TRANSADELAIDE INFRASTRUCTURE SERVICES		
PART 10: TRACK SUPPORT SYSTEMS		DOC. NO. CP-TS-960
Issue: 3	Date: 22/09/08	Page: 22 of 27

7.0 MONITORING AND MAINTENANCE OF FORMATION AND BALLAST

7.1 INSPECTION, ASSESSMENT AND MAINTENANCE ACTIONS

Inspections shall include the specific conditions shown in table 7.1:

Table 7.1: Inspection, assessment and maintenance actions

Type of inspection	Specific actions or conditions to observe
Scheduled inspections	
Walking inspections	<p>a) Identify visually and report formation, track drainage and ballast defects and conditions that may affect track stability. This includes ballast profile deficiencies, which may reduce track lateral resistance under temperature induced rail stresses. The conditions shown in sub-section 7.2 and any other defects affecting track support and stability are to be identified and reported.</p> <p>b) Intervals between walking inspections shall not exceed 31 days</p>
Unscheduled inspections	To be justified and undertaken in accordance with “unscheduled inspections” as defined in CP-TS-953 (Infrastructure management and principles).
Assessment, method of assessment, response and maintenance action	<p>a) Degradation of ballast shoulders shall be considered on the basis of the cross-sectional area of ballast shoulder remaining and providing resistance to lateral movement. Table 7.2 shows for various conditions of the ballast shoulder the maximum restricted speed to be imposed.</p> <p>b) Restrictions shall be imposed when the ballast condition in the table 7.2 extends over a length equal to or greater than 10m.</p> <p>c) If the condition of the ballast profile is sub-standard and cannot be rectified immediately, the operating speed shown in table 7.2 shall be compared to the existing speed limit and if less, then a temporary speed restriction shall be imposed no higher than the value shown in table 7.2. Table 7.2 shows for each type of sleeper (timber, steel or concrete) and for different heights and widths of shoulder ballast, the speed limit corresponding to that condition.</p> <p>d) Excess ballast, as defined in clause 7.6, shall not incur a speed restriction but action shall be taken to restore the profile shown in table 4.1 prior to the next inspection.</p> <p>e) The assessment of formation and ballast condition shall be in accordance with sub-section 7.3</p>

7.2 FORMATION AND BALLAST DEFECTS AND CONDITIONS

Ballast defects and conditions that may affect track stability include the following:

- a) track sections with inadequate ballast profile;
- b) track sections where the ballast profile may foul the operation of infrastructure, eg signals or switches, or rolling stock;
- c) mud holes or wet spots that may affect the deterioration rate of the track condition including pumping sleepers;



CODE OF PRACTICE - VOLUME TWO - TRAIN SYSTEM [CP2] TRANSADELAIDE INFRASTRUCTURE SERVICES		
PART 10: TRACK SUPPORT SYSTEMS		DOC. NO. CP-TS-960
Issue: 3	Date: 22/09/08	Page: 23 of 27

- d) indications of poor sleeper support by ballast, eg cracking of sleepers and bearers, excessive vertical sleeper movement;
- e) sleeper skewing, lack of crib ballast, heaped ballast or gaps between sleepers indicating longitudinal track movement;
- f) heaped ballast or gaps at sleeper ends indicating lateral track movement; or a migration of ballast away from the track;
- g) accelerated loss of track geometry, (eg following wet or dry weather) that may indicate poor ballast quality;
- h) evidence of excessive track vibration (eg powdered or rounded ballast);
- i) areas and extent of fouled ballast or poor ballast drainage that have resulted or may result in wet spots or mud holes in wet weather;
- j) heaving of soil adjacent to the track which may indicate sub-soil failure. Cesses are higher than the formation under the sleepers and ballast. Cesses must always be lower than the formation level below the ballast, and should be lowered where they have been raised by silt or heave of the earthworks;
- k) location and extent of narrow formation, that is formation that is too narrow to maintain the design ballast profile;
- l) water pockets caused by subsidence of the track and formation under the combined action of traffic and water;
- m) slips in cuttings or on embankments occur mostly in clay weakened by the presence of excess water;
- n) shrinkage cracks in the formation need to be filled in during dry weather;
- o) ditches and open channels are to be kept clean and silt removed to another location where it can not re-enter the drains;
- p) where drains have been provided down the sides of embankments, these should be checked for condition;
- q) open jointed pipe drains – The filling over the pipes should be clear of non-granular material that may prevent the free passage of water. Pipes and pipe sockets should be unobstructed. Catchpits should be free of silt and covers in good order;
- r) any obstacles, which may interfere with track drainage;
- s) location and extent of substantial weed growth;
- t) other defects affecting track stability.

7.3 BALLAST PROFILE DEFICIENCIES

- a) Where the ballast profile is assessed to be deficient, it may be necessary to either restore the ballast section immediately or impose a temporary speed restriction.
- b) Table 7.2 shows for each type of sleeper (timber, steel or concrete), the maximum permissible speed for different degrees of deficiency. Figure 7.1 defines the terms used in table 7.2.

Table 7.2: For each sleeper type the permissible speed (in kilometres per hour) for different combinations of shoulder width and depth are as shown below (note: Speeds applicable on curves $\leq 400\text{m}$ radius are shown in brackets):

TIMBER SLEEPERS (Sleeper depth = 130mm)
--



CODE OF PRACTICE - VOLUME TWO - TRAIN SYSTEM [CP2] TRANSADELAIDE INFRASTRUCTURE SERVICES		
PART 10: TRACK SUPPORT SYSTEMS		DOC. NO. CP-TS-960
Issue: 3	Date: 22/09/08	Page: 24 of 27

Distance from top of ballast to top of sleeper	Shoulder width				
	0mm	100mm	200mm	300mm	400mm
0mm	Normal speed				
30mm					
100mm	20 (10*)	40 (10*)		40 (20)	
130mm	10*				

STEEL SLEEPERS (Sleeper depth = 96mm)					
Distance from top of ballast to top of sleeper	Shoulder width				
	0mm	80mm	230mm	300mm	
0mm	Normal speed				
30mm	Normal (40)				
70mm	40 (10*)	65 (10*)	Normal speed (20)		
96mm	20 (10*)				

CONCRETE SLEEPERS (Sleeper depth = 256mm)					
Distance from top of ballast to top of sleeper	Shoulder width				
	0mm	80mm	230mm	300mm	
0mm	Normal				
60mm	speed				
190mm	65 (40)				
256mm	40 (20)				

*Note: Where a speed limit of 10km/h applies all train movements are to be piloted until the track is brought up to a standard where a higher speed limit is applicable.

CODE OF PRACTICE - VOLUME TWO - TRAIN SYSTEM [CP2] TRANSADELAIDE INFRASTRUCTURE SERVICES		
PART 10: TRACK SUPPORT SYSTEMS		DOC. NO. CP-TS-960
Issue: 3	Date: 22/09/08	Page: 25 of 27

Figure 7.1: Definition of terms used in table 7.2

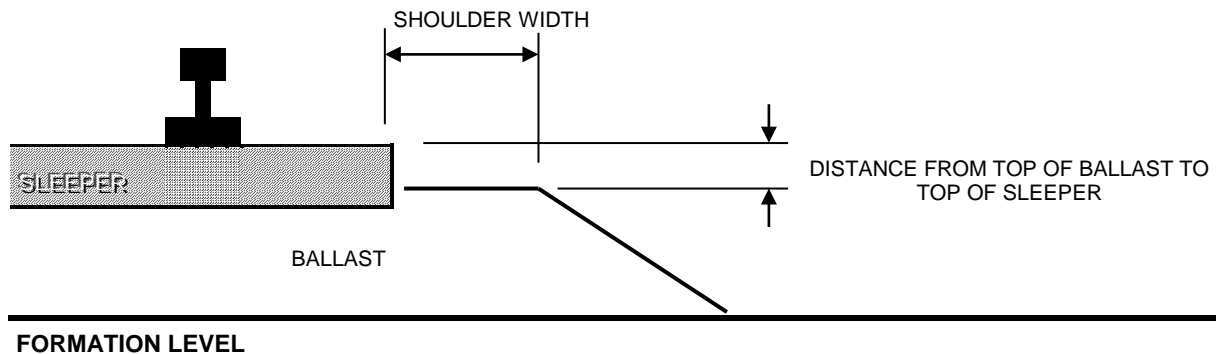

7.4 PUMPING

Excessive vertical movement of a sleeper i.e. greater than 25mm, generally revealed by the presence of mud or slurry, is a condition defined as “pumping.” Track geometry criteria is generally affected by pumping. The method of detection is visual and follow up inspections are to be made once pumping is detected. Action to be taken in response to this condition is shown in table 7.3:

Table 7.3: Track pumping (all sleeper types); maximum speed limits

Track pumping:	Action required
over 3 or less consecutive sleepers	No action
over 3 to 10 consecutive sleepers	Impose speed limit of 60km/h or repair
over more than 10 consecutive sleepers	Impose speed limit of 40km/h or repair

7.5 UNCONSOLIDATED BALLAST

Unconsolidated ballast results from the tamping and ballast renewal processes and may increase the possibility of track instability with temperature variations if ballast is not consolidated under traffic or by other means (i.e. mechanical ballast stabilization, crib and shoulder compaction).

Where, during any 7 day period, tamping or ballast renewal extends over a section of track exceeding 10m in length, speed restrictions due to unconsolidated ballast shall be imposed as follows:

- a) Tamping with minimum lift < 25mm: no speed restriction required;
- b) Tamping with lift \geq 25mm and < 75mm: a 40km/h speed restriction for 3 week days [see note 1] under traffic, after which the track condition is to be re-assessed and restriction lifted or extended;
- c) Tamping with lift \geq 75mm or major track reconditioning with complete ballast renewal:
 - i. For timber and steel sleepers: a 25km/h speed restriction for 7 week days [see note 1] under traffic;
 - ii. For concrete sleepers: a 40km/h speed restriction for 3 week days [see note 1] under traffic; after which the track condition is to be re-assessed and restriction lifted or extended.



CODE OF PRACTICE - VOLUME TWO - TRAIN SYSTEM [CP2] TRANSADELAIDE INFRASTRUCTURE SERVICES		
PART 10: TRACK SUPPORT SYSTEMS		DOC. NO. CP-TS-960
Issue: 3	Date: 22/09/08	Page: 26 of 27

Note [1]: in clauses (b) and (c), a Saturday, Sunday or Public Holiday shall be considered as equal to half a week day.

- d) Restrictions on lifting and other precautions to be taken during hot weather are specified in CP-TS-964 (Rail stress control).

7.6 EXCESS BALLAST

Excess ballast shall be defined as ballast above the profile shown in table 4.1, which has not been put there for some approved purpose (e.g. construction road, access road, etc.). Where excess ballast inhibits effective inspection of sleepers and fastenings it shall be recorded as a defect and shall either (1) be removed prior to the next inspection, or (2) a detailed inspection and assessment shall be carried out to determine the condition of the track.



CODE OF PRACTICE - VOLUME TWO - TRAIN SYSTEM [CP2] TRANSADELAIDE INFRASTRUCTURE SERVICES		
PART 10: TRACK SUPPORT SYSTEMS		DOC. NO. CP-TS-960
Issue: 3	Date: 22/09/08	Page: 27 of 27

8.0 DOCUMENTATION

8.1 TRACK CONFIGURATION RECORD

The Track Configuration Record shall schedule the various track configurations on TransAdelaide's tracks in accordance with QP-IS-501 (Document and Data Control). The Track Configuration Record shall also record data as specified in CP-TS-961 (Rails and rail joints). *RECORD TO BE DEVELOPED*

8.2 INSPECTION REPORTS

All inspection reports shall be maintained in accordance with CPRD/PRC/046 Records Management.