

PRODUCT MANUAL

THE MAJOR & THE GENERAL
**ARROWQUIP ARMY
SERIES**

MAJ-V2 | GEN-V2



MARCH 2026

1-877-275-6075
cs@arrowquip.com
arrowquip.com



WARNING

PLEASE FOLLOW ALL SAFETY INSTRUCTIONS PROVIDED IN THIS MANUAL BEFORE OPERATION.

ARROWQUIP DOES NOT ACCEPT RESPONSIBILITY FOR ANY ACCIDENTS OR INJURY WHEN THIS SAFETY MANUAL HAS NOT BEEN READ IN FULL AND KEPT WITH THE PRODUCT AT ALL TIMES.

OPERATORS OF THIS PRODUCT TAKE AND ACCEPT RESPONSIBILITY FOR ANY HARM OR INJURY TO THE ANIMAL OR OPERATOR WHEN IT PERTAINS TO HOW THE EQUIPMENT IS USED AND MAINTAINED.

Please keep this manual for frequent reference and to pass on to new users or owners.

CONTENTS

SAFETY GUARANTEE	6
SAFETY PRECAUTIONS	7
RISK ASSESSMENT	8
HEAVY-DUTY HYDRAULIC SQUEEZE CHUTE OVERVIEW	9
THE GENERAL SPECIFICATIONS.....	9
THE MAJOR SPECIFICATIONS.....	10
SWING ARM SPECIFICATIONS.....	11
ARMY SERIES HYDRAULIC SQUEEZE CHUTE ASSEMBLY	13
CONSIDERATIONS.....	13
CONNECTING TO HYDRAULIC POWER.....	16
HYDRAULIC POWER UNITS.....	18
POWER PACK FLOW CONTROL.....	19
POWER PACK PRESSURE RELIEF.....	20
OPERATING THE ARMY SERIES HYDRAULIC CATTLE CHUTE	21
ELECTRIC POWER PACK RUN-UP AND SHUTDOWN.....	21
GAS POWER PACK RUN-UP & SHUTDOWN.....	21
TRACTOR HOOKUP RUN-UP & SHUTDOWN.....	22
HOW TO USE CHUTE CONTROLS.....	23
POWER FAILURE.....	24
RECOMMENDED MAINTENANCE	25
MAINTENANCE SAFETY.....	25
REGULAR MAINTENANCE.....	25
HYDRAULIC MAINTENANCE.....	28
THE MAJOR QUICK COUPLER CROSS REFERENCE.....	29
TROUBLESHOOTING GUIDE	30
WARRANTY	32
ADD-ONS & INSTALLATION INSTRUCTIONS	33
ARMY HYDRAULIC JACK KIT.....	34
ARMY HYDRAULIC WHEEL KIT.....	54
HYDRAULIC NECK EXTENDERS.....	63
THE GENERAL POWER BEYOND KIT.....	80
THE MAJOR POWER BEYOND KIT.....	90
HEAD GATE SHOULDER CUSHIONS.....	99
CALF RESTRAINER BAR.....	101
STERNUM BAR.....	103
WHEEL KIT [75WK].....	105

SAFETY GUARANTEE

Arrowquip is committed to creating safe cattle management experiences. With this commitment to safety, in the event any purchaser of Arrowquip equipment is **physically injured while operating the equipment AND requires medical treatment**, Arrowquip will provide a **full refund** of the equipment purchase price and the purchaser will be allowed to keep the equipment. Equipment must be warranty-registered, and the purchaser must read and practice the contents and recommended maintenance and procedures outlined herein to be eligible.

Arrowquip also commits to repair or replace any part of the equipment that is defective, malfunctions or otherwise falls under normal use and inside the equipment's warranty terms. If the equipment requires replacement, it shall be replaced with an identical model or a newer model of the equipment. For further details, visit arrowquip.com/promise.

SAFETY PRECAUTIONS



WARNING:

Read below before operation.

Ensure the operator understands the contents of this manual before using the cattle squeeze chute.

1. **DO NOT** wear loose-fitting clothing.
2. Ensure the equipment is on a firm, level, dry surface that is free of rocks and other trip hazards.
3. **DO NOT** enter the vet cage until the animal is secured in the head gate.
4. **DO NOT** stand in front of the head gate while operator is moving the cattle through the squeeze chute.
5. **DO NOT ALLOW CHILDREN UNDER THE AGE OF 18 NEAR AN OPERATING MACHINE.**
6. Follow safe cattle handling procedures in other areas of the yard so that cattle are more docile.
7. **DO NOT** make any modifications to Arrowquip equipment. Non-factory modifications to the equipment can reduce the safety for the operator and livestock.
8. **DO NOT** operate hydraulics while operators are working with the cattle in the chute or are touching the chute. Reaching out or into the chute while hydraulics are in operation can result in serious injury.
9. Please ensure that all hydraulic hoses and electrical leads are out of the way and safely positioned before moving cattle or using the chute.
10. Keep a distance of more than an arm's length from the hydraulic chute while hydraulics are in operation.

RISK ASSESSMENT

Conduct a risk assessment on procedures regarding the operation of an Arrowquip hydraulic squeeze chute, establishing a safe work procedure.

1. Ensure all users of the equipment have been inducted and comply with safe working procedure.
2. Please ensure that there are NO large or hazardous objects inside the equipment that may cause injury to the animal or operator or may cause the equipment to malfunction.
3. Ensure that access gates are closed securely before running cattle through the chute.
4. Make sure that your equipment has been cleared of **ALL** livestock after use.
5. Make sure all moving components are secured before installing transport kits for applicable units.
6. Some chemicals and medicines can damage powder coat. Take all precautions and wash after use.
7. Please ensure that the hydraulic chute is secured on firm ground.
8. Please ensure that all hydraulics work properly before putting cattle through the chute.
9. Please make sure that all hydraulic hoses are properly secured to the hydraulic pump or tractor.
10. Ensure that the hydraulic controls are functioning properly.
11. If hydraulics do not function properly when testing the equipment, **DO NOT** put cattle through the chute.

HEAVY-DUTY HYDRAULIC SQUEEZE CHUTE OVERVIEW

THE GENERAL SPECIFICATIONS

PRODUCT CODE	GEN-V2
OIL TYPE	AW22
MAX FLOW RATE	45.4LPM / 12 GPM
RECOMMENDED OPERATING PRESSURE	6894kPa/1000PSI
MAX OPERATING PRESSURE	8273kPa / 1200PSI
WEIGHT	4,200 lbs / 1,905 kg

DIMENSIONS

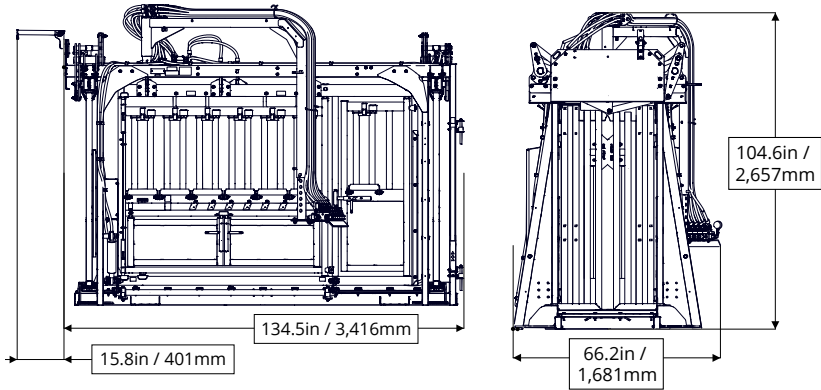

*THE GENERAL SHOWN WITH OPTIONAL TOOL HANGER.

THE MAJOR SPECIFICATIONS

PRODUCT CODE	MAJ-V2
OIL TYPE	AW22
MAX FLOW RATE	45.4LPM / 12 GPM
RECOMMENDED OPERATING PRESSURE	6894kPa/1000PSI
MAX OPERATING PRESSURE	8273kPa / 1200PSI
WEIGHT	3,900 lbs / 1,769 kg

DIMENSIONS

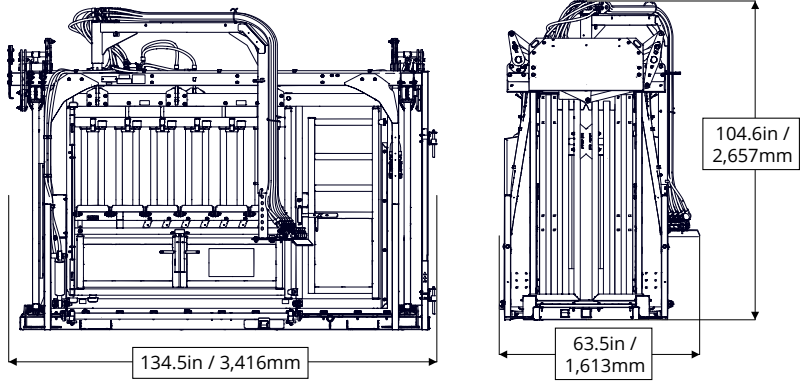

SWING ARM SPECIFICATIONS

SWING ARM CLEARANCE

For swing arm to have full range of travel approximately 4.5' of clearance is needed from the chute frame side, and 4' of clearance needed from the front of the chute.

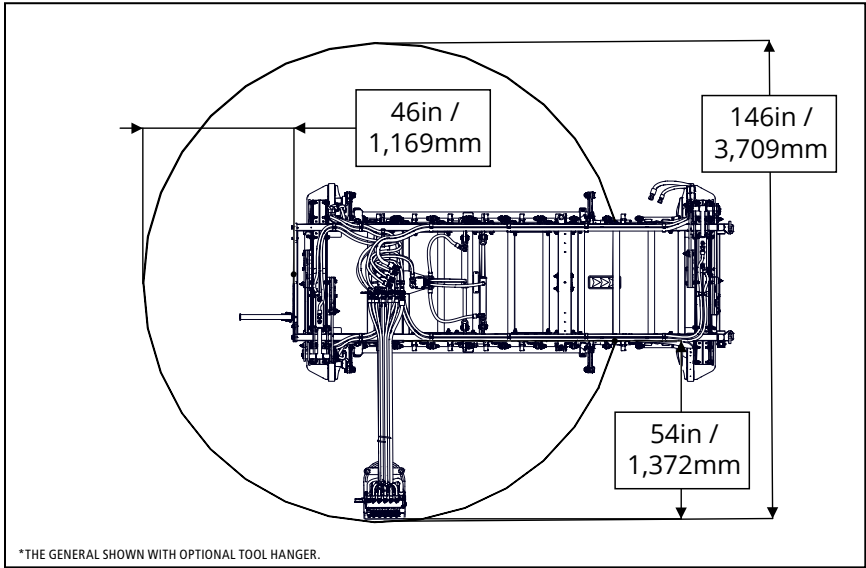

The Army Series swing arms includes 180° of swivel and 12" of height adjustment for valve bank controls.

Swivel adjustment can be made by firmly grasping valve bank plate and rotating. If you are having difficulty adjusting or position is not holding, loosen or tighten the swivel adjustment bolt as necessary.

SWING ARM ADJUSTMENT

Swing arm height can be adjusted with the following steps.

1. Using 3/4" wrench, loosen tensioning bolt.

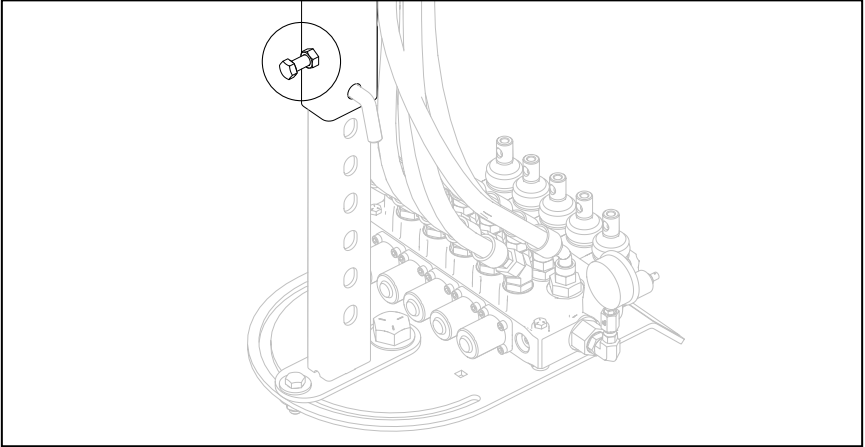

NOTE: Ensure valve plate is well supported when proceeding to step 2. Assembly weight is approximately 50lbs. It is recommended to have a second person help support the plate during adjustment.

2. Remove adjustment pin and move control plate to desired height. Reinsert the pin.

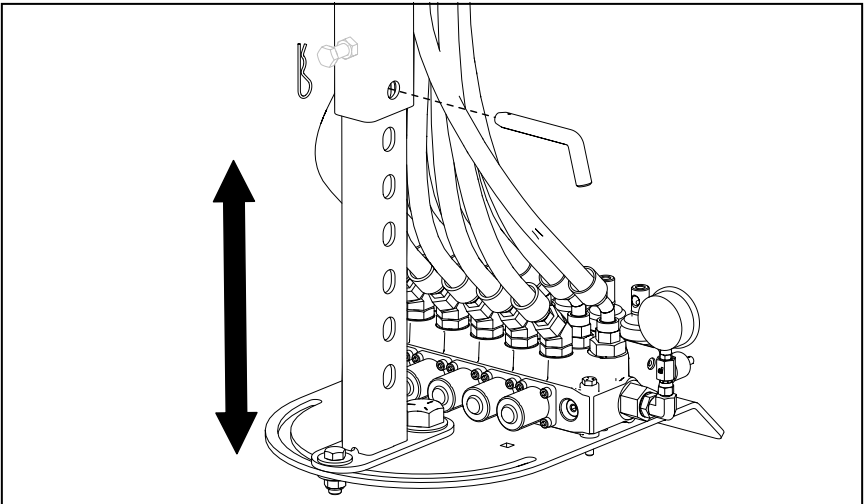

3. Tensioning bolt can now be fastened to tighten control arm connection.

ARMY SERIES HYDRAULIC SQUEEZE CHUTE ASSEMBLY

CONSIDERATIONS

Your Army Series Hydraulic Squeeze Chute can be moved with a loader by lifting from the squeeze frame through the bolt on shipping brackets. Arrowquip recommends removing the 4X shipping brackets from the squeeze frame once the chute has been transported to its working location and will not be moved with a loader afterward.

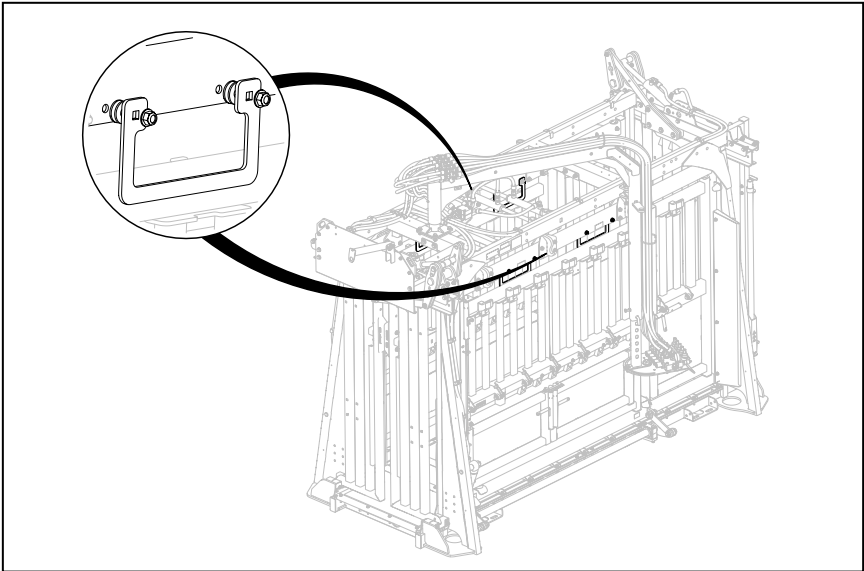

It is recommended to install your Army Series Hydraulic chute on level, solid ground for correct operation. When creating a working area for your chute installation, whether it be packed earth or poured concrete, consider the following:

- The size of the pad or working area should be large enough to use the full swing arm travel.
- How will the height of your working area affect the alley leadup to the chute?
- Will you be installing load bars? This will affect connection heights.
- Is there room in your working area to use the emergency exits off the sides of the chute?
- Will you need the ability to draft animals to different pens after the chute?
- Do you have access to power?
- How easy is access for manure cleanout?

Dual width panel clips are provided on the rear of all Arrowquip Chutes and can be pinned to the leadup with the provided 1/2" panel pins. The width and heights of the connections are shown below:

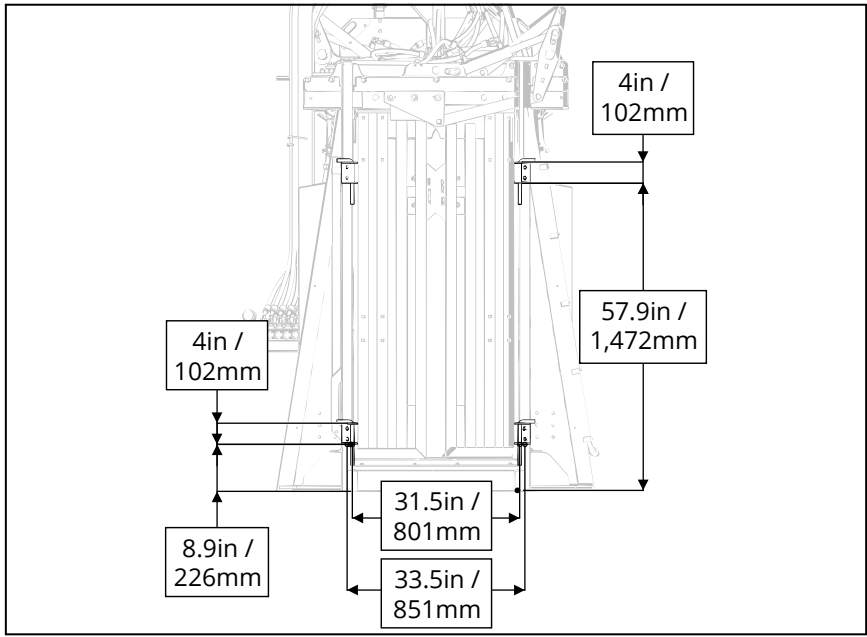

MOUNTING & LOAD BARS

The unit comes equipped with mount brackets for permanent installation to the ground and are designed to work with most well-known brands of load bars such as Tru-Test and Gallagher. Mounting dimensions are below:

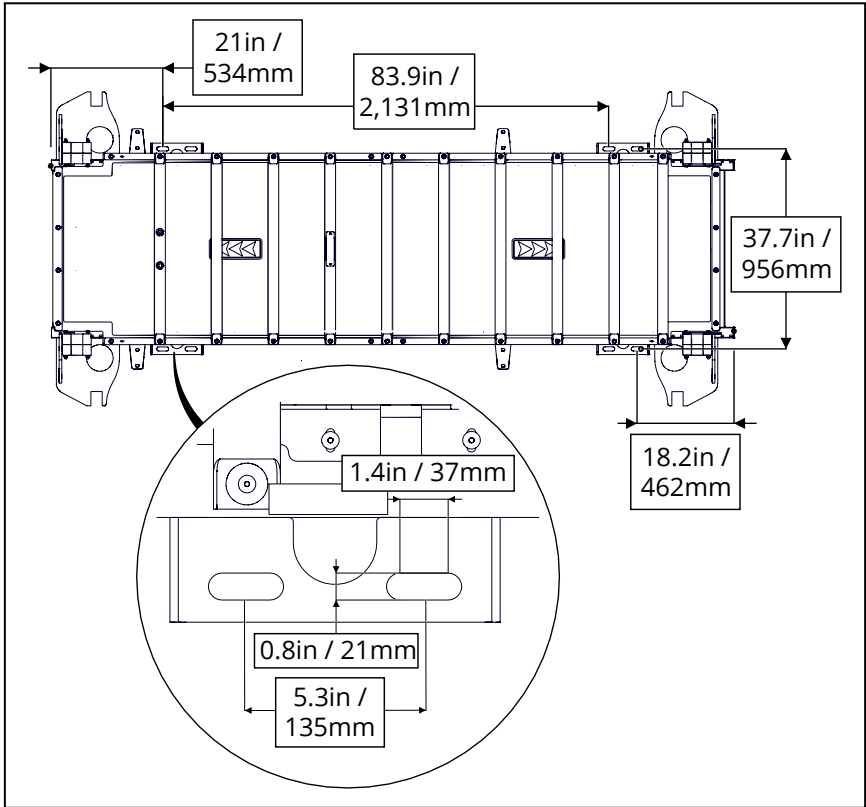

CONNECTING TO HYDRAULIC POWER

Arrowquip Army Series Hydraulic Chutes require a hydraulic power source. The chute comes with two 40ft ground lines to create a hydraulic circuit and allow the power unit to be placed a distance from the chute.

- The pressure line is marked with **RED** tape.
- The tank line is marked with **YELLOW** tape.

The hookup of each chute is different.

NOTE: Tractor hydraulics have higher flow than what is required by Arrowquip hydraulic chutes and can be damaged if connected directly to a tractor. Some tractors come equipped with flow controls but typically will not drop lower than the maximum chute flow rate of 12GPM. **Never connect the chute directly to tractor hydraulics.**

THE GENERAL

Since The General is a stationary chute, it comes with groundlines pre-plumbed to the chute through a JIC connection, with the correct connectors on the end for Arrowquip Hydraulic Power Packs. The hoses are routed to the ground from factory but hold downs can be removed to run the hoses above the chute instead of along the ground.

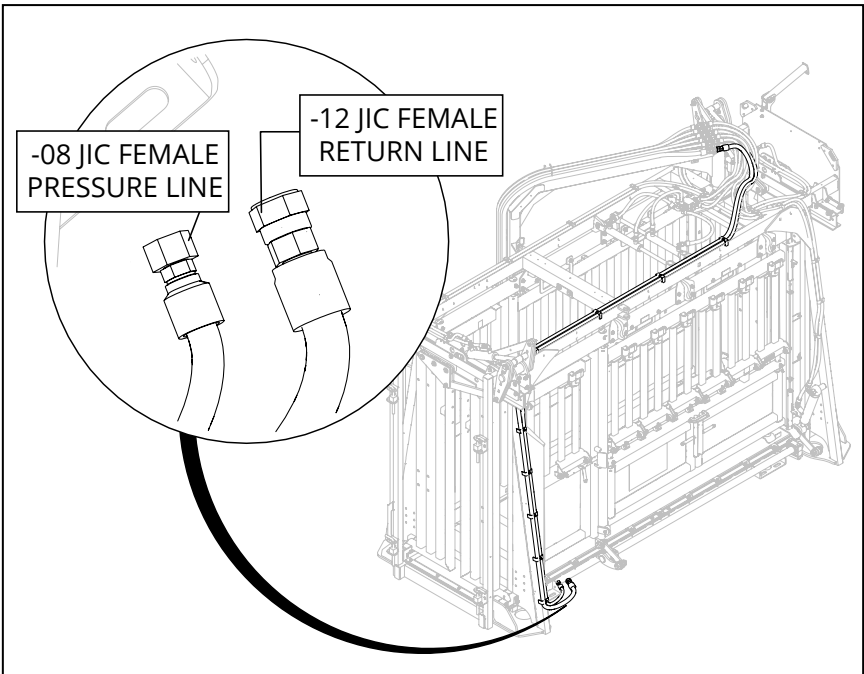

THE MAJOR

The Major is powered through groundlines that hookup to 1/2" quick couplers that are located on the side of the chute at the rear.

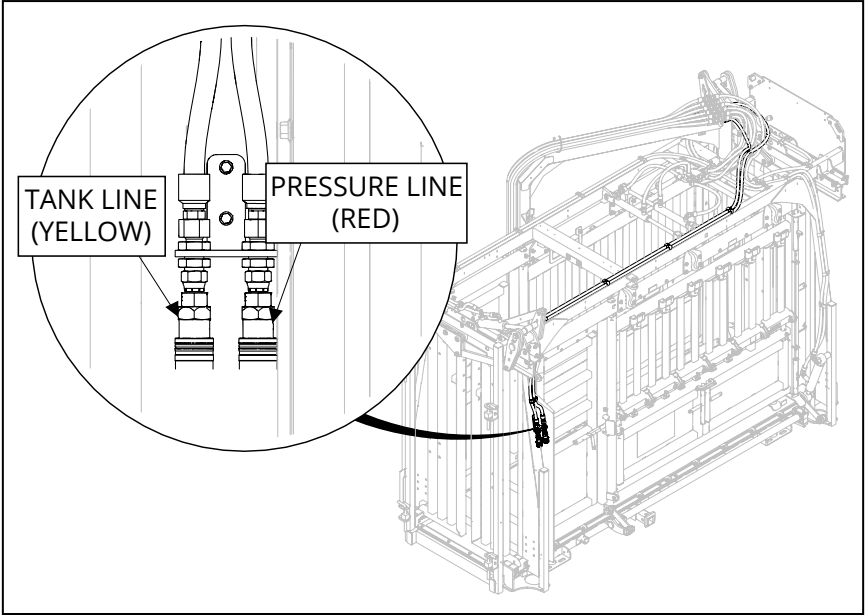

HYDRAULIC POWER UNITS

Arrowquip provides multiple powerpack options for the Army Series depending on your use case.

For more detailed information concerning the Power Pack models below please refer to the Power Pack manual.



Scan the QR code or visit arrowquip.com/resources/owners-hub.

SMART CODE	FULL DESCRIPTION	PART NUMBER (PN)	USE CASE
HPP-1E75-LF	7.5HP SINGLE PHASE ELECTRIC LOW-FLOW POWER PACK	2033202	THE MAJOR
HPP-3E75-LF	7.5HP THREE PHASE ELECTRIC LOW-FLOW POWER PACK	2033214	THE MAJOR
HPP-1E75-HF	7.5HP SINGLE PHASE ELECTRIC HIGH-FLOW POWER PACK	2033210	THE GENERAL THE MAJOR
HPP-3E75-HF	7.5HP THREE PHASE ELECTRIC HIGH-FLOW POWER PACK	2033211	THE GENERAL THE MAJOR
HPP-G10-LF	10HP GAS POWER PACK	2033153	THE MAJOR
GEN-TH	TRACTOR HOOK UP	9000429	THE GENERAL* THE MAJOR* *INTENDED FOR BACKUP USE ONLY

POWER PACK FLOW CONTROL

Arrowquip built Power Packs are equipped with a Walvoil SD4 spool valve that serves to redirect fluid flow and protect the system from over pressurizing.

The switch on the top of the spool valve has two settings:

- When the switch lever is in the **horizontal position** the system is in **Neutral/Recirculation mode**.
- When the switch is **flipped upward** the system is in **Active/Powered mode**.

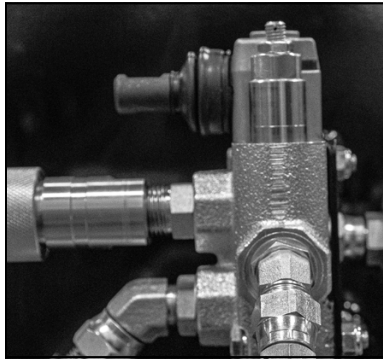

NEUTRAL/RECIRCULATION MODE directs fluid through the oil filter and back to the tank, even if the Power Pack is hooked up to a chute. This mode allows you to start up the Power Pack with virtually no load, decreasing wear and tear on the motor or engine. This mode is also used to pre-heat the oil on colder days before running the chute up.

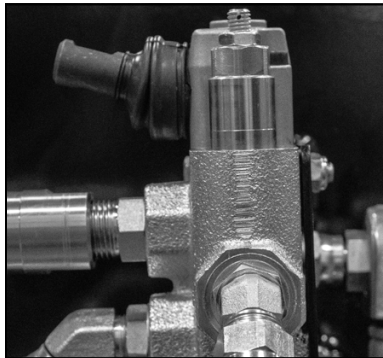

ACTIVE/POWERED MODE directs fluid out of the top 1/2" quick connect to the equipment being powered then returns to the Power Pack via the 3/4" quick connect, where it is filtered before being dumped to tank.

POWER PACK PRESSURE RELIEF

The pressure relief valve redirects fluid back to the tank when the system pressure rises above a factory set pressure of 1200PSI. This protects the system from over pressurizing if the unit is put into Active/Powered mode without being connected to a chute.

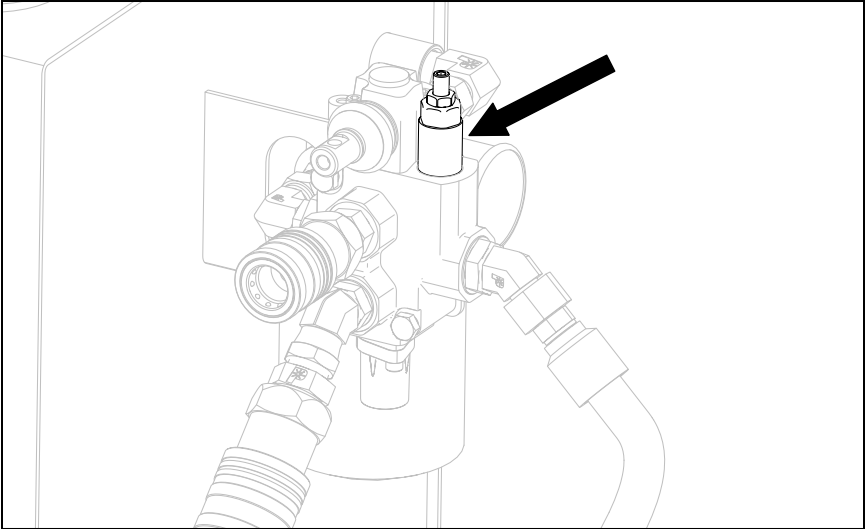

WARNING:

Do not adjust the pressure relief, as it is set to keep animals safe inside Arrowquip products. If the Power Pack's maximum pressure needs to be changed, please contact Arrowquip's Client Care team.

OPERATING THE ARMY SERIES HYDRAULIC CATTLE CHUTE

When hooked up to hydraulic power source and flow is engaged to the chute, it is normal to read a pressure on the gauge without touching the chute. The pressure should read in the range of 200-500PSI. From the factory, the pressure relief in the valve bank is set to 900PSI. Do not adjust the pressure above this setting.

NOTE: Increasing pressure relief will not increase the speed of the chute functions.

ELECTRIC POWER PACK RUN-UP AND SHUTDOWN

NOTE: To avoid premature motor wear always ensure that the Power Pack is in Recirculation mode before starting.

1. Plug in Power Pack.
2. Ensure pressure and return hoses are hooked up correctly.
3. Flip Power Pack into powered mode.
4. After cattle working session is complete, flip Power Pack back to Recirculation mode.
5. Un-plug Power Pack.

GAS POWER PACK RUN-UP & SHUTDOWN

NOTE: If you're using your Power Pack on hard-packed ground or concrete, it's best to engage the kickstand to keep it from moving due to vibration.

1. Ensure Flow Control is set to Recirculation mode
2. Engage choke, fully engage throttle, pull to start.
3. Let engine warm up, it should be running smooth with no choke applied.
4. Ensure pressure and return hoses are hooked up correctly.
5. Flip Power Pack into Powered mode.
6. After cattle working session is complete, flip Power Pack back to Recirculation mode, throttle down engine to idle and let cool for 2-5 mins.
7. Shutdown engine by positioning throttle all the way down.

TRACTOR HOOKUP RUN-UP & SHUTDOWN

The full procedure should be followed whenever connecting to a new tractor to set optimal flow rate. Below are the hookup locations:

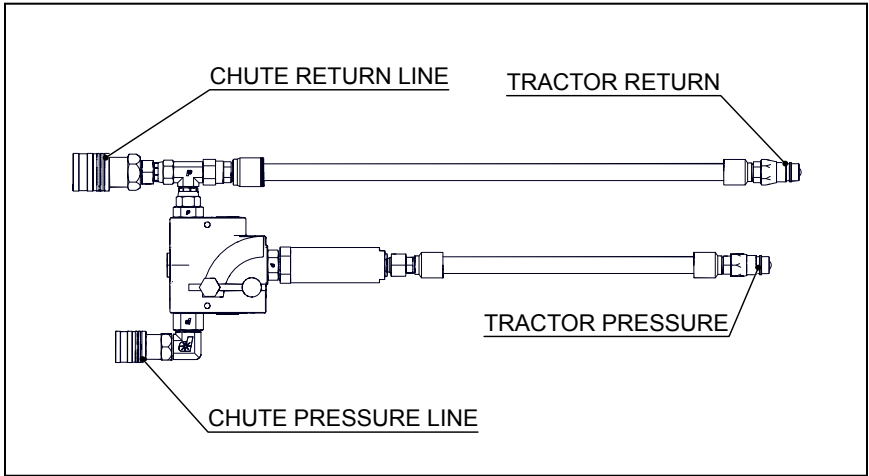

1. Before connecting to equipment ensure flow control is set to zero flow as shown.

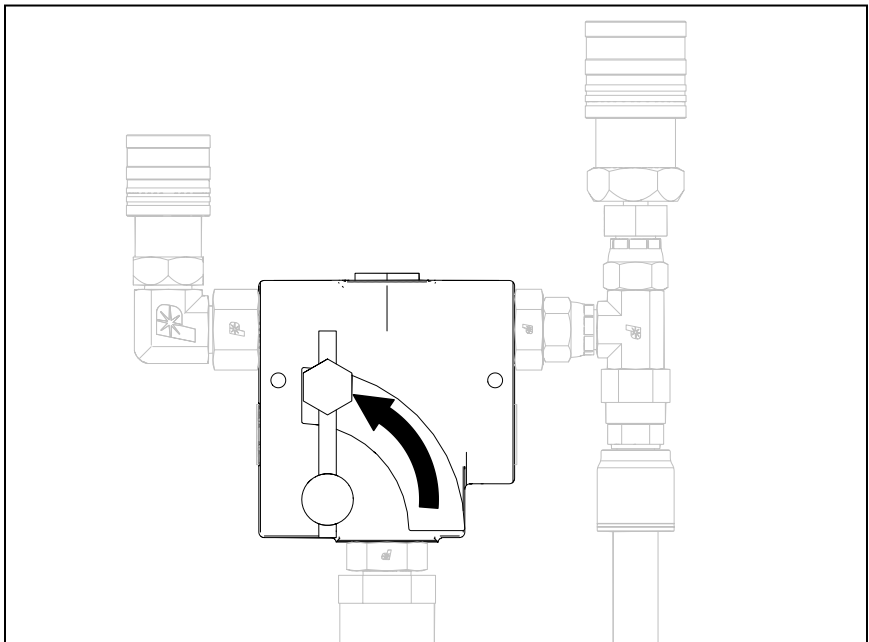

2. Ensure male and female couplers on adapter are clean and free of debris.
3. Connect tractor adapter to pressure and tank lines on the tractor and ground lines.
4. Engage hydraulics with tractor.
5. Now you can increase the flow control from 0-1 and test the head gate function (lever furthest to left). It will likely be sluggish at this setting. Gradually increasing flow setting and testing head gate open/close speed. The target speed for the closing head gate is around 0.5s.
6. Once optimal setting is found, turn down thumbscrew to lock position.
7. When working session concludes, disengage tractor hydraulics, disconnect flow control from tractor. Groundlines can remain connected for next session.

HOW TO USE CHUTE CONTROLS

The controls on Army Series chutes are set up intuitively, where pulling on the lever will open a function and pushing on the lever will close the function. Functions are labeled with infographic decal below valve bank.

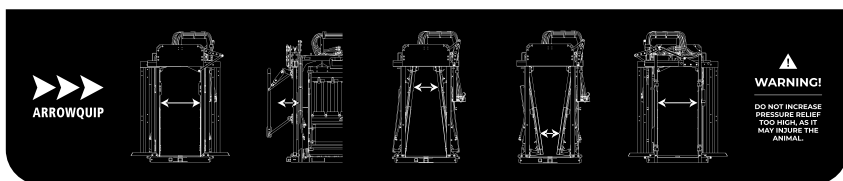

ENSURE ALL CHUTE FUNCTIONS AND ADD-ONS ARE WORKING PROPERLY BEFORE OPERATING.

1. Ensure the head gate, tail gate, and all access points are closed before the animal enters the chute.
2. Set head gate having it slightly more than the neck size of the animal.
3. Set the squeeze
 - a. Set top squeeze according to size and age of animal you are working:
 - i. If closed too much: larger animals will balk.
 - ii. If open to wide: smaller animals may attempt to turn around.
 - b. Start with the bottom completely open to allow the animal to have a wide steady stance.
4. Open tail gate for the animal to enter the squeeze chute.
5. Close tail gate.
6. When animal is in the correct position, quickly close the head gate securely on the animal's neck.
7. Once caught in the head gate, the side squeeze and neck extenders can be engaged to further restrain movement as required.
 - a. If neck extenders are slipping past the animal's ears, push head gate function again before extending neck extenders.

8. If needing to enter the chute to work behind the animal, it is highly recommended to put the included rump bar behind the animal for added safety.



CONFIRM ANIMAL IS SECURELY HELD BEFORE CARRYING OUT ANY HUSBANDRY WORK.

POWER FAILURE

If you should experience a loss of power while you have an animal in the chute, please follow the instructions below:

1. Operate the hydraulic levers to allow fluid to flow out of the cylinders and release the pressure on the animal.
2. With the levers engaged, pull on the Head Gate Door / Squeeze Panel to open the door if necessary.
3. Check to make sure the animal is free of any injury.
4. Release the animal from the chute.
5. Review the cause for power failure and troubleshoot to restore power.

RECOMMENDED MAINTENANCE

All Arrowquip products are made with precision parts to require minimal maintenance. However, regular maintenance will keep your equipment running smoothly and safely.

MAINTENANCE SAFETY

1. Ensure the area is clear of bystanders, especially children, when doing any maintenance or repair on the hydraulic squeeze chute.
2. Keep all body parts, including hair, hands, feet, etc., away from the machine when hydraulics are in operation.
3. Before carrying out any maintenance on the squeeze chute, please ensure there are no livestock in the chute.
4. **DO NOT** repair the chute or go into the chute when hydraulics are in operation. This can result in injury to the worker. Unplug the motor before performing any necessary repairs or inspection.

REGULAR MAINTENANCE

DAILY

- Inspect the entire unit. Ensure all moving components are free of debris and function properly.
- Clean bottom head gate door track and chute floor.
- Ensure area under torsion tube linkages on both sides of the unit are clear of manure to allow full squeeze travel.

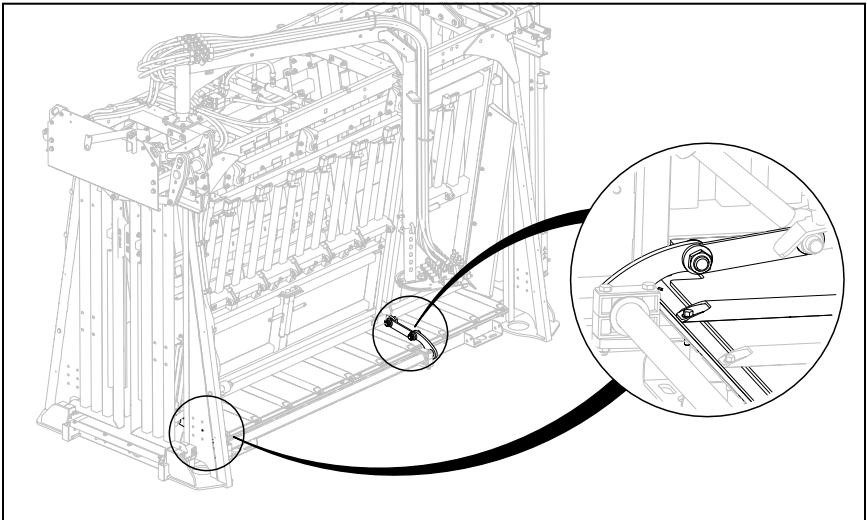

- Inspect rubber shoulder cushions for excessive wear. If material is torn exposing retaining strip and screw heads cushions should be replaced.

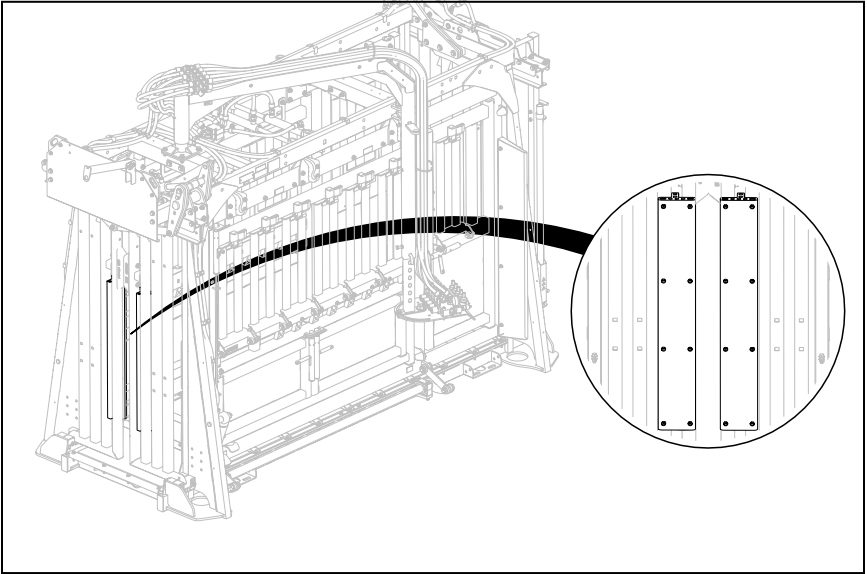

- Ensure HG track is not dry. If dry, lubricate all track surfaces along the length of head gate and tail gate. We suggest WD-40, but any oil-based lubricant will work.

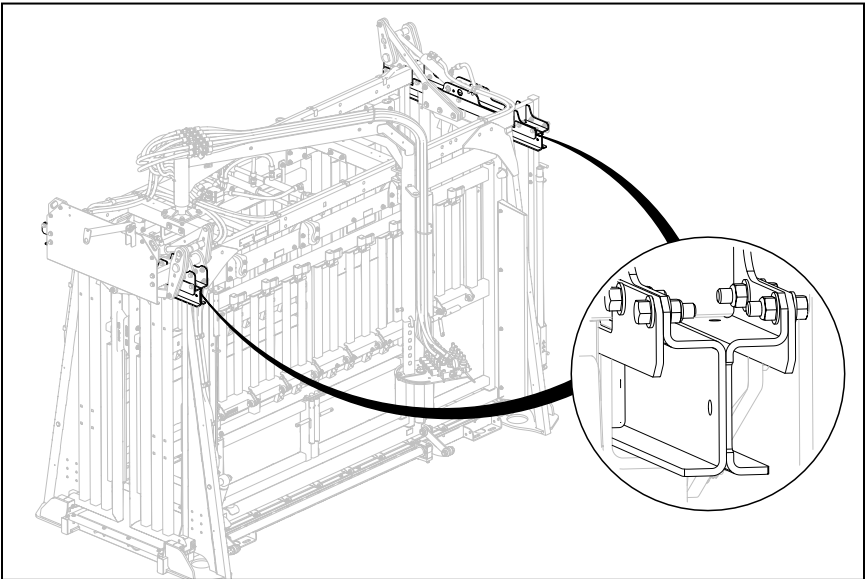

PER 1000 HEAD OR ANNUALLY

- Grease cylinders, head gate, tail gate and swing arm pivots through provided grease zerk (15 Places).

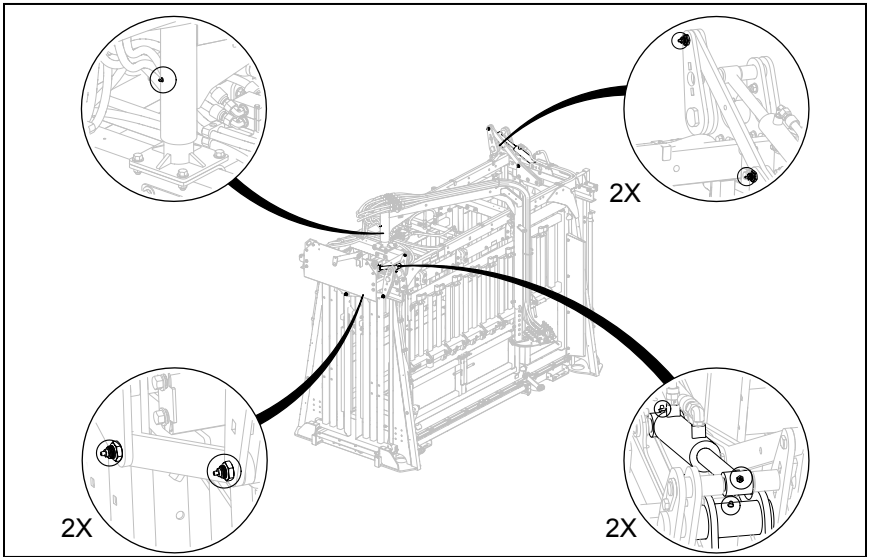

- Lubricate slam latches, door hinges, pillow blocks and non-greaseable cylinders with WD-40 (42 places).

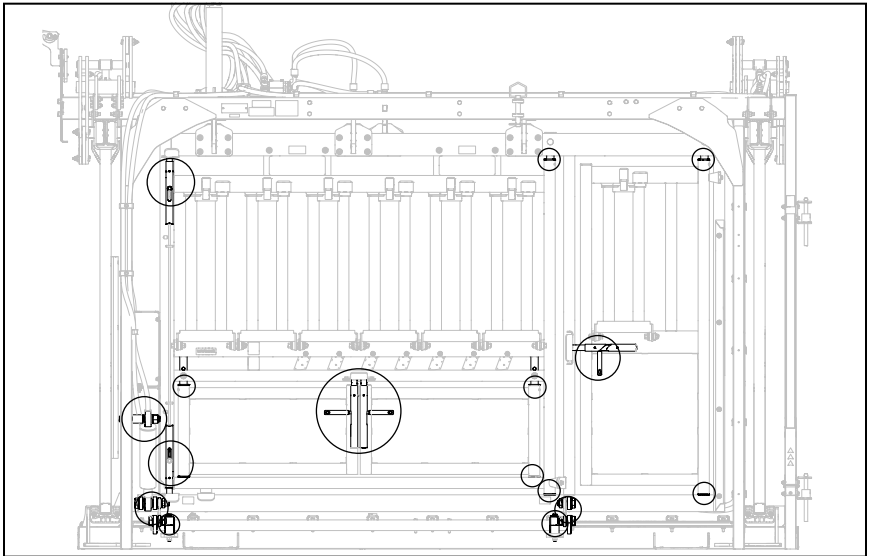

HYDRAULIC MAINTENANCE

Arrowquip Powerpacks and hydraulic chutes are shipped from factory with ISO 22 AW hydraulic oil to be able to function in hot and very cold climates. Depending on your location this oil may not be available. Depending on how cold it gets in your region or if your working facility is heated, you can consider using the following oils.

HYDRAULIC OIL STANDARD	MINIMUM OPERATING TEMPERATURE
ISO 32 AW	-10C / 14F
ISO 46 AW	0C / 32F
ISO 68 AW	8C / 46F

Replace the hydraulic oil after 2,000 hours of run time, or sooner if needed. If the oil is beginning to become cloudy or muddy, your system might have water contamination. Replace oil as soon as possible as it can cause critical damage to the Power Pack and chute components.

THE MAJOR QUICK COUPLER CROSS REFERENCE

Quick couplers have a designated lifespan and in time seals inside may fail resulting in a leak. If you need to replace either the female coupler on your chute or the male coupler on your ground line, you can refer to the brand cross reference below. This will ensure you can find the coupler you need locally.

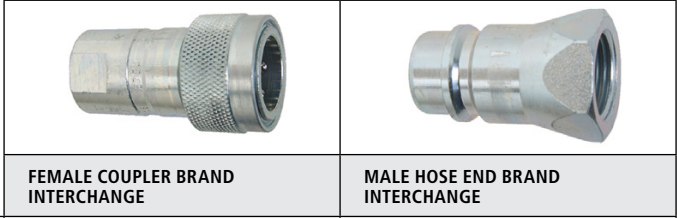

BRAND	PART NUMBER (PN)	PART NUMBER (PN)
PULSAR	C401-08	C404-08
PERFECTING	4AGF4-PV	AG4FOF4-PV
AEROQUIP	N/A	N/A
DNP	NS-08-08-C-NPT	NS-08-08-N-SAE
FASTER	NS12NPTF	N/A
HANSEN	N/A	N/A
HOLMBURY	DINB12-F-08N	DINB12-MS-08S
PARKER	4050-4P	8010-15
SAFEWAY	S25-4	S71-4P
SNAP-TITE	61C-8-8-F	N/A
STUCCHI	F IRV 12 NPT	N/A

TROUBLESHOOTING GUIDE

If you have a problem with your Army Series Hydraulic Squeeze Chute please consider the following tips or call Client Care at 1-877-275-6075.

ISSUE: Left and right-bottom squeeze functions are out of sync, or bottom squeeze appears to be drifting..

1. Run the bottom squeeze function all the way out.

NOTE: Cylinders must be completely retracted for Rephasing to occur.

2. Continue to hold the control for 1-2 minutes as this will allow the cylinders to re-phase and push any trapped air out of the system.

ISSUE: Neck extender out of sync.

1. Extend the neck extender function fully so both cylinders are fully retracted.
2. Continue to hold the control for 1-2 minutes as this will allow the cylinders to re-phase and push any trapped air out of the system.
3. Ensure there is nothing impeding the travel of the neck extender.

ISSUE: Animals can pull their heads through neck extenders.

1. Ensure neck extender mounts are slotted. Ensure the mounts are pushed towards the inside of the chute.

ISSUE: Cannot get quick connects to seat.

1. Relieve pressure in permanently mounted lines:
 - a. Insert a punch into the center of the female couplers on the chute and apply pressure. The inner poppet should depress and relieve the pressure in the line.
2. Relieve pressure in the ground lines running to the power pack:
 - a. Hit the end of the male coupler against a hard flat surface. This will depress the poppet relieving the pressure in the line.
3. If the weather is below -10C/14F than female couplers may require heating to move and seat correctly.

ISSUE: Power pack is running but no pressure at chute, or chute controls work incorrectly.

1. Check Hydraulic oil level in power pack reservoir.
2. Check that the power pack is in powered mode.
3. Remove plastic shield from bellhousing on power pack and inspect jaw couplings, replace if necessary.
4. Check that power pack groundlines are connected to the chute.
5. Ensure pressure and return lines are connected correctly at the chute. Try swapping the lines.

6. If issue persists reach out to Client Care.

ISSUE: Gas engine power pack will not start

1. If colder than -18C or 0F engine may not start and need to be warmed first.
2. Check fuel in tank.
3. Check oil level.
 - a. The Vanguard 300 comes with a low oil sensor that will not allow the sparkplug to fire.
4. Check sparkplug.
 - a. If sparkplug is coated in fuel or fowled, it may need to be cleaned or have excess fuel burnt off.
 - b. Excess fuel in cylinder may also need to be removed. With fuel off pull over engine, ensuring no persons or animals are near the sparkplug port as excess fuel will dissipate through here.
5. For a full guide to troubleshooting small engines:



WARRANTY

Your product must be registered to claim warranty, and to ensure that Arrowquip has the required information to contact you in the event of a product or part recall. Any owner who fails to register their product warranty with Arrowquip through their Authorized Arrowquip Dealer voluntarily voids their warranty.

Arrowquip will repair or replace products or parts of a product that prove defective due to manufacturer defect during the Warranty Period, at their sole discretion. This excludes defects resulting from normal wear and tear or product misuse.

NOTE: Any modification, in any fashion, to any Arrowquip equipment immediately voids the product warranty. This includes the parts contained therein.

E.g. If a modification is made to the squeeze mechanism in a squeeze chute, and the sternum bar is bent afterwards, warranty for the damaged part, the sternum bar, contained in the modified equipment, the squeeze chute, is void. In addition, any remaining warranty for the squeeze chute and other parts contained therein, including, but not limited to, the head gate, locking system, Arrowlock or Powerlock system, and rollers, is null and void.

IDENTIFICATION

Smartcodes are shorthand forms for Arrowquip products to quickly determine which product you have. The smartcode and serial number can be found in the location shown.

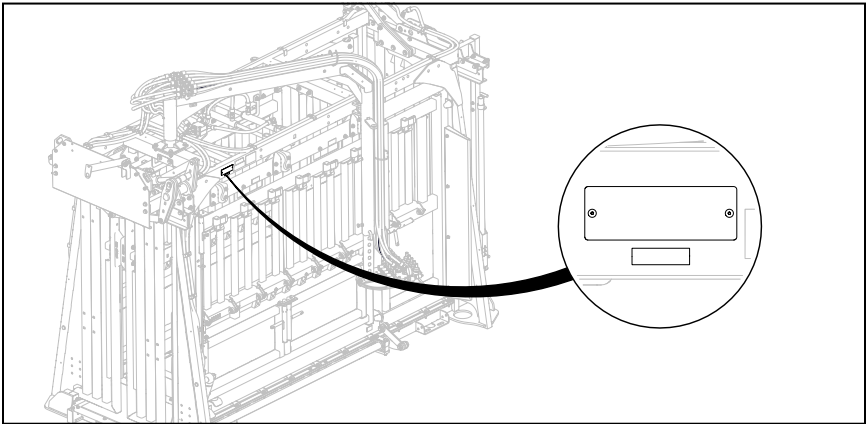

REGISTER FOR WARRANTY NOW:

ONLINE: arrowquip.com/product-registration

PHONE: 1-877-275-6075 | **EMAIL:** cs@arrowquip.com

ADD-ONS & INSTALLATION INSTRUCTIONS

The Army Series Hydraulic Squeeze Chute is available with the following options to meet the needs of your operation. While options are typically ordered from the factory, if your chute does not come equipped with what you need, please contact Arrowquip Sales for the option that suits your needs below.

<p>ARMY HYDRAULIC JACK KIT INSTALL INSTRUCTIONS PAGE 34</p>	<p>ARMY HYDRAULIC WHEEL KIT INSTALL INSTRUCTIONS PAGE 54</p>	<p>HYDRAULIC NECK EXTENDERS INSTALL INSTRUCTIONS PAGE 63</p>
<p>THE GENERAL POWER BEYOND KIT INSTALL INSTRUCTIONS PAGE 80</p> <ul style="list-style-type: none"> • Adds 5 more hydraulic controls for hydraulics in your system 	<p>THE MAJOR POWER BEYOND KIT INSTALL INSTRUCTIONS PAGE 90</p> <ul style="list-style-type: none"> • Adds 5 more hydraulic controls for hydraulics in your system 	<p>ARMY TOOL HANGER*</p>
<p>HEAD GATE SHOULDER CUSHIONS INSTALL INSTRUCTIONS PAGE 99</p> <ul style="list-style-type: none"> • Comes standard 	<p>CALF RESTRAINER BAR INSTALL INSTRUCTIONS PAGE 101</p>	<p>STERNUM BAR INSTALL INSTRUCTIONS PAGE 103</p>
<p>WHEEL KIT [75WK] INSTALL INSTRUCTIONS PAGE 105</p>		





*Install instructions not included

ARMY HYDRAULIC JACK KIT

REQUIREMENTS:

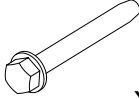
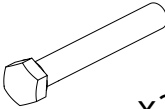
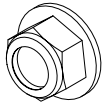
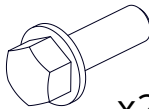
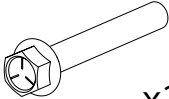
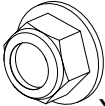
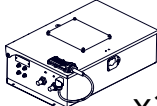
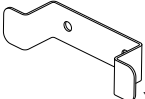
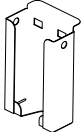
- 2 people
- 12Volt battery charger (with AGM/Deep cycle mode)
- 6L of 22AW oil
 - If 22AW is unavailable in your area, request the lightest hydraulic oil your supplier carries.
- Ladder
- Lifting device
- Wrenches or Sockets
 - 2 x 9/16"
 - 2 x 3/4"
 - 2 x 11/16"
 - 1-1/2"

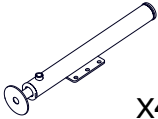
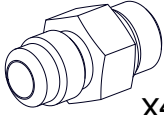
USER ASSEMBLY PARTS LIST

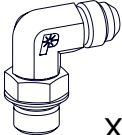
7003213 THRD-CUT BOLT Z 1/4-20X2" TFL  x9	7003183 BOLT-HH-0.375- 16-2.75-Z-5  x2	7003178 NUT-FNYL-0.375- 16-Z-5  x2	7003004 BOLT-FLG-0.5-13- 1.5-Z-5-FT  x24
7003070 BOLT-FLG-0.5-13- 3.5-Z-5-FT  x2	7003177 NUT-FNYL-0.5- 13-Z-5  x26	2011754 GEN HJ BOX ASSY  x1	2037789 JACK BOX CORD WRAP - BLK  x1
2004313 PORTABLE JACK PENDANT HOLDER  x1	2017004 1/4 INCH HOSE CLIP  x24	2010734 GENERAL HYD JACKS WELDING  x4	9000004 06-06 M ORB-JIC CONNECTOR  x4
9000719 06-06 M F JIC 45° ELBOW  x4	9000005 06-06 M ORB-JIC 90° ELBOW  x4	9000984 ARMY JACK REAR CAP HOSE x2	9000985 ARMY JACK REAR ROD HOSE x2
		9000982 ARMY FRONT JACK CAP HOSE x2	9000983 ARMY FRONT JACK ROD HOSE x2

OPERATING THE HYDRAULIC JACKS:

Refer to this guide to ensure safe operation of the Hydraulic Jacks.

- Arrowquip hydraulic jacks are run with a 4-button pendant with symbols: F↑, F↓, R↑, R↓.
- "F" for Front, "R" for Rear, and the "↑↓" arrows indicate which direction the foot of the jack will travel.
 - Ex. pressing F↓ will move the foot of the front jack down, lifting the front of the unit.
- When lifting or lowering the unit, alternate between front and rear jacks to maximize stability. Difference between rear and front chute height should not exceed 8".
- Only lift the unit when on firm level ground.
- Never raise the unit more than necessary to put on tires.
- If left and right sides are not lifting evenly do not continue lifting unit.
 - This indicates that the jack box battery is low and needs to be charged before unit will lift evenly.

If you have any questions, please contact Client Care at 1-877-275-6075 for assistance.

INSTALLATION:

NOTE:

- The instructions below show the Army Hydraulic Jack kit being installed on a second-generation The Major Hydraulic Chute. The process for installation is the same for all other compatible chutes.
- Swing arm has been removed from views for clearer visuals.
- Chute will need to have hydraulic power as functions will need to be used occasionally to allow installation access. Install four Head Sweep Door Mounts (2002835) with 1/2" x 3" long carriage bolt (7002295) and 1/2" nuts (7003177) in the provided holes. Note orientation of Head Sweep Mount and hardware installation direction.

1. Install Jack Pendant Mount (2004313) as shown using 3/8" x 2.75" hex head bolts (7003183) and nuts (7003178).

NOTE: plugs in the frame will need to be removed and can be discarded.

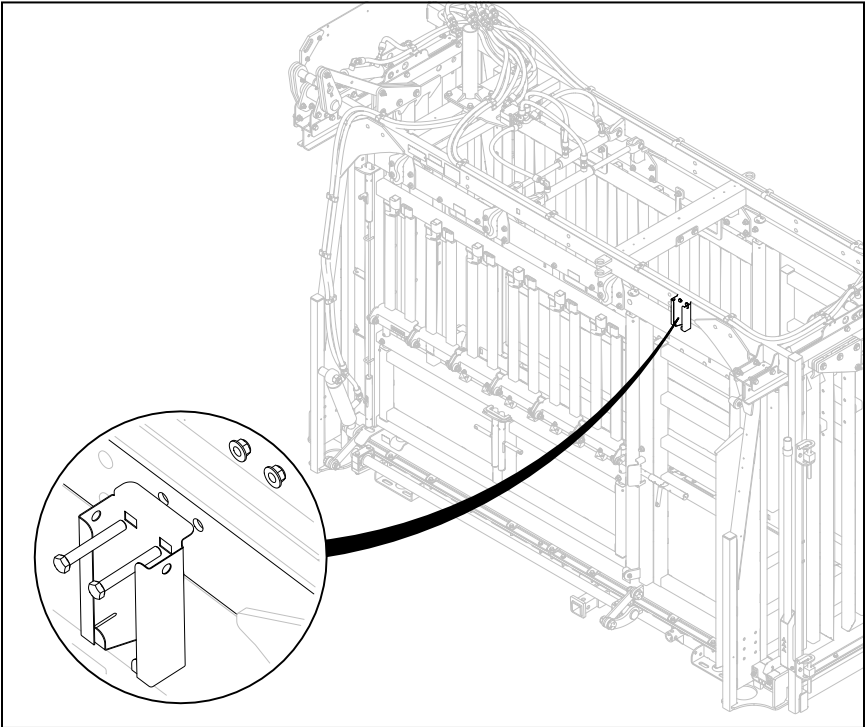

2. Install cord wrap bracket (2037789) as shown using 1/2" x 3.5" flange head bolts (7003070) and nuts (7003177).

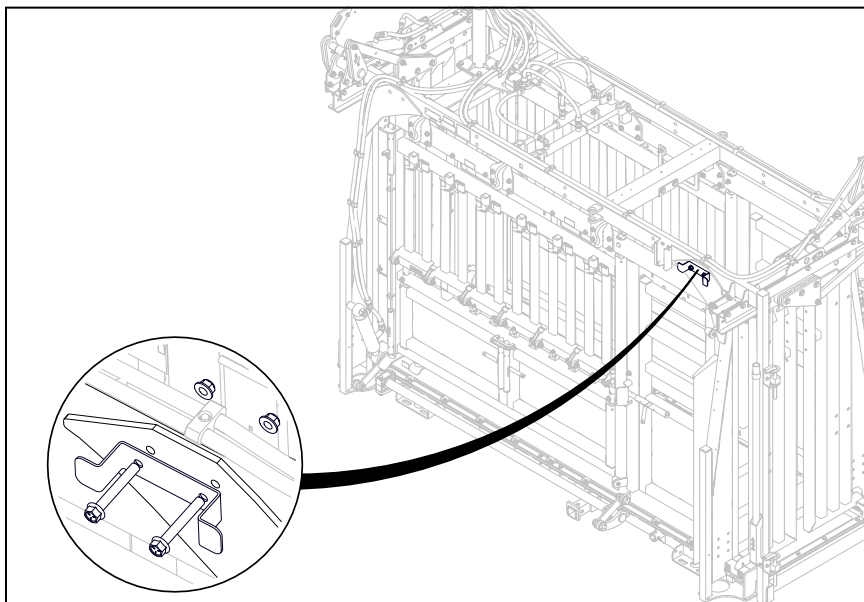

3. Prepare chute for jack box installation.
- a. Remove self-tapping bolts and hose clips holding preinstalled hoses to frame rail.

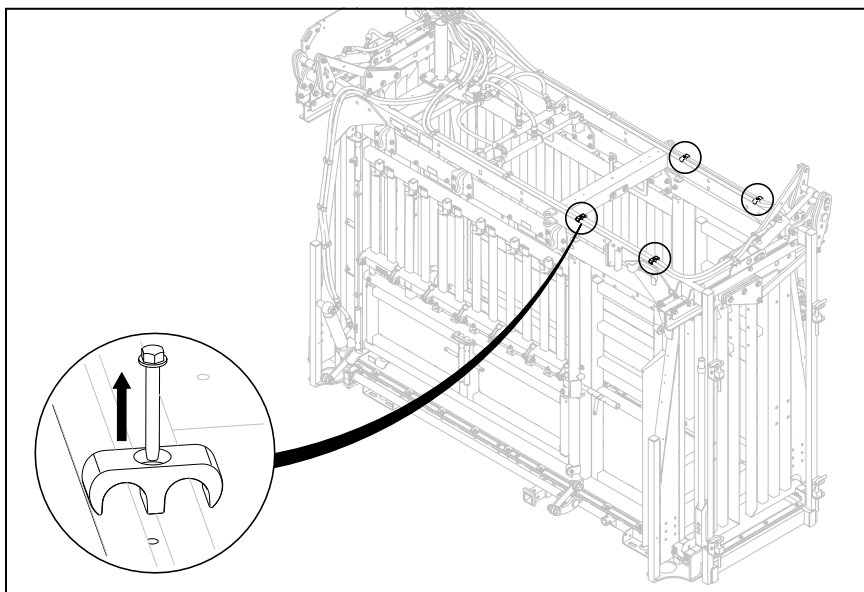

- b. Pull hoses aside to expose top of frame rail.
- c. Remove preinstalled 3/8 hardware. Set aside for later step.

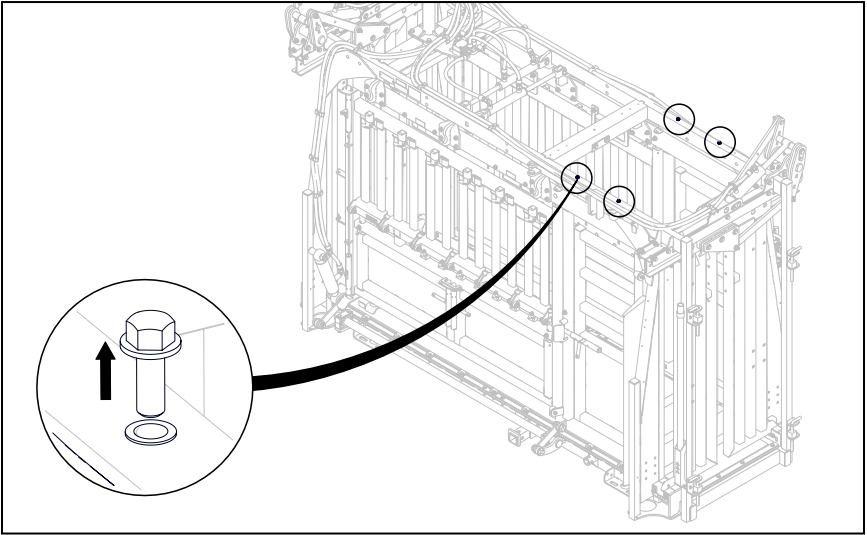

NOTE: The jack box weighs over 120lbs and it is strongly recommended to use a lifting device to install.

- 4. Using a lifting device move jack box assembly (2011754) into position with the latch facing the back of the chute as shown. Hoses will not reach if the jack box is installed in the wrong orientation.

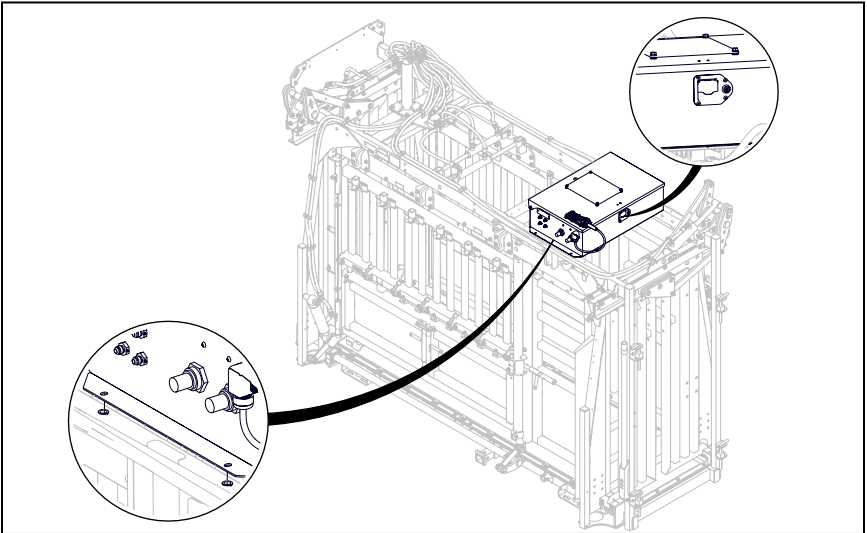

5. Install hardware removed in step 3c to rigidly mount jack box.
6. Sub-assemble the four jacks (2010734).
 - a. Install ORB-JIC straight fitting (9000004) in the top port of the jacks.

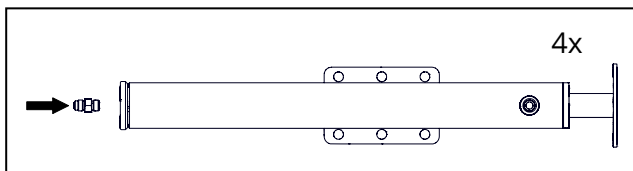

- b. Install ORB-JIC 90° fitting (9000005) and M F JIC 45° fitting (9000719) as shown.

- i. Below shows the orientation for front left and rear right jacks.

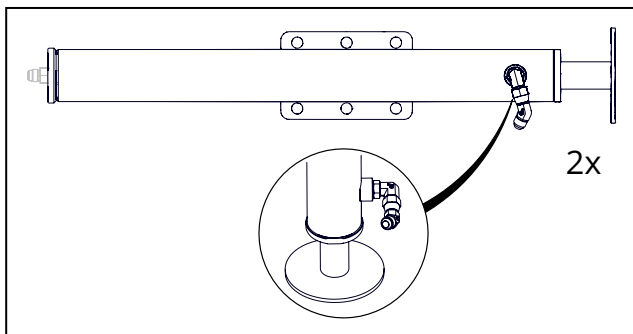

- ii. Below shows the orientation for front right and rear left jacks.

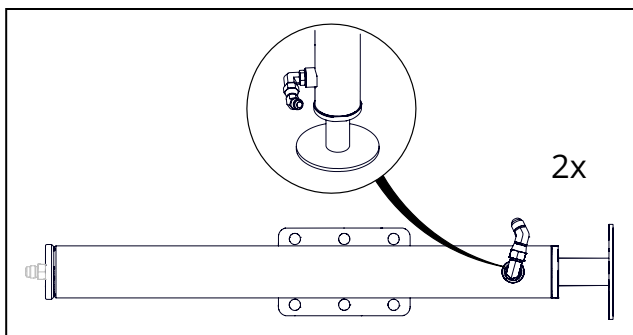

c. Jacks can be placed at the four corners of the chute for later.

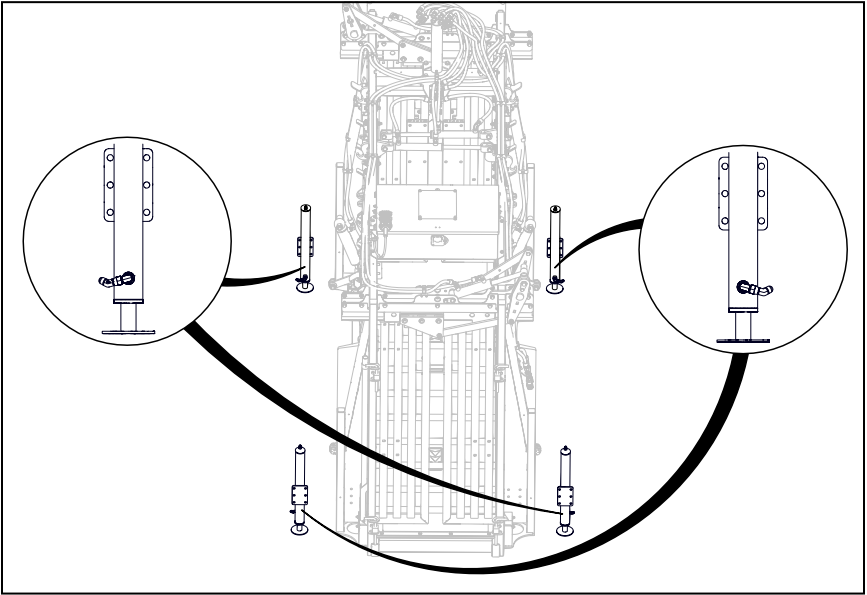

7. Route rear hoses.

a. Connect the 90° crimp end of hose (9000984) to the bottom rear port on the jack box in the orientation shown.

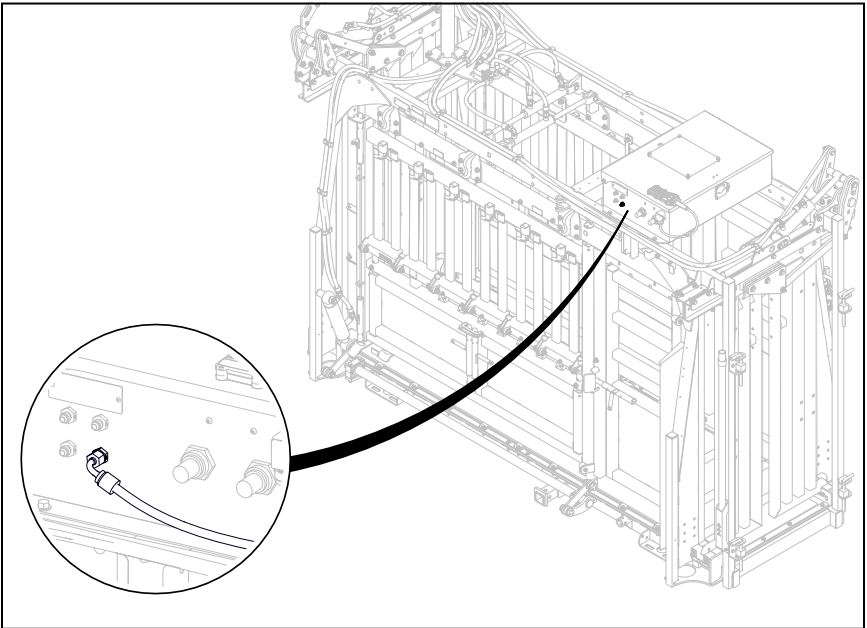

- b. Connect the 90° crimp end of hose (9000985) to the top rear port on the jack box in the orientation shown.

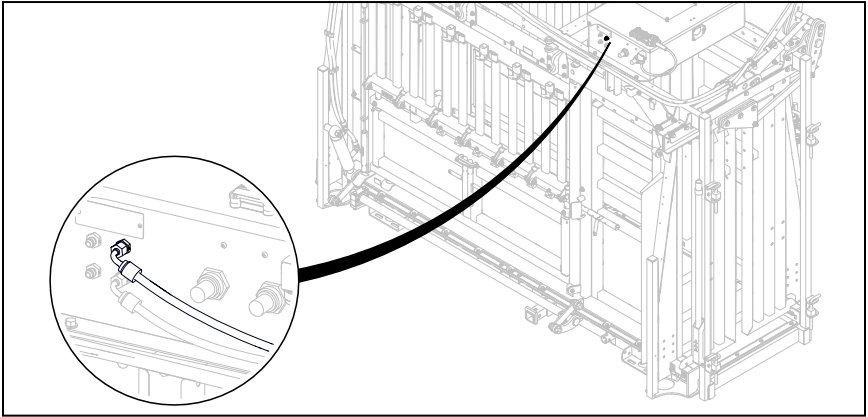

- c. Use hose clip (2017004) and 1/4" thread cutting bolt (7003213) to begin routing hoses as shown. Re-use preinstalled thread cutting bolts where applicable.

NOTE:

- Tighten enough to hold the hose but loose enough that you can adjust the amount of slack in the hose.
- Number of pre-installed thread cutting bolts will differ on the offside rear frame of chute due to ground lines being routed down the frame from factory.

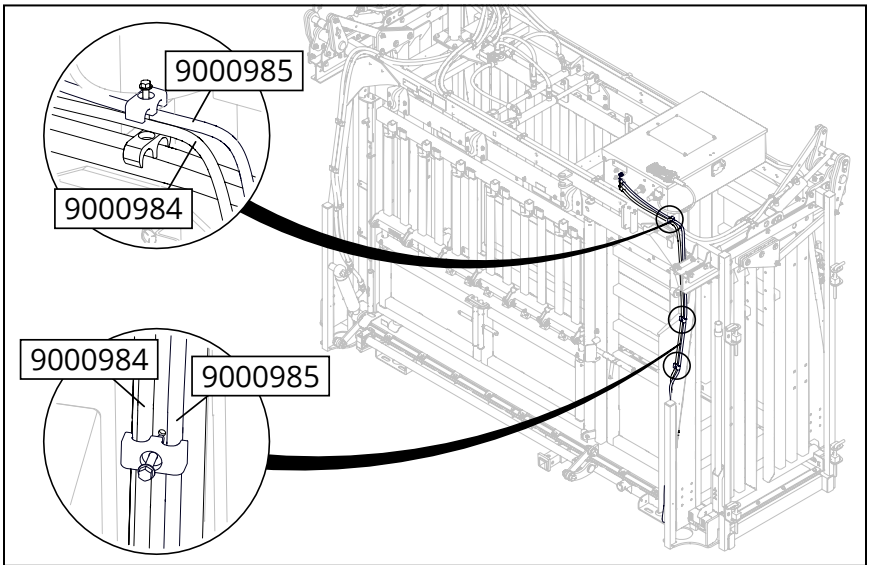

- d. Connect jack hose (9000984) to the cap side of the hydraulic jack and connect jack hose (9000985) to the rod side of the hydraulic jack, leave loose for bleeding (step 9).

NOTE: The cap side is the sealed, fixed end of the cylinder. The rod side is where the rod extends out.

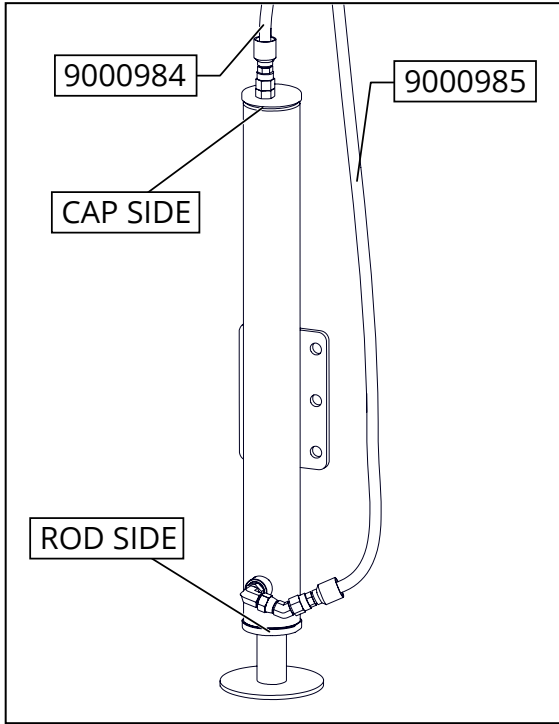

- e. Repeat on opposite side.
- f. Jacks can be set aside, unmounted, at rear of chute until bleeding step.

8. Route front hoses.

- a. Connect the 90° crimp end of army front jack cap hose (9000982) to the bottom front port on the jack box in the orientation shown.

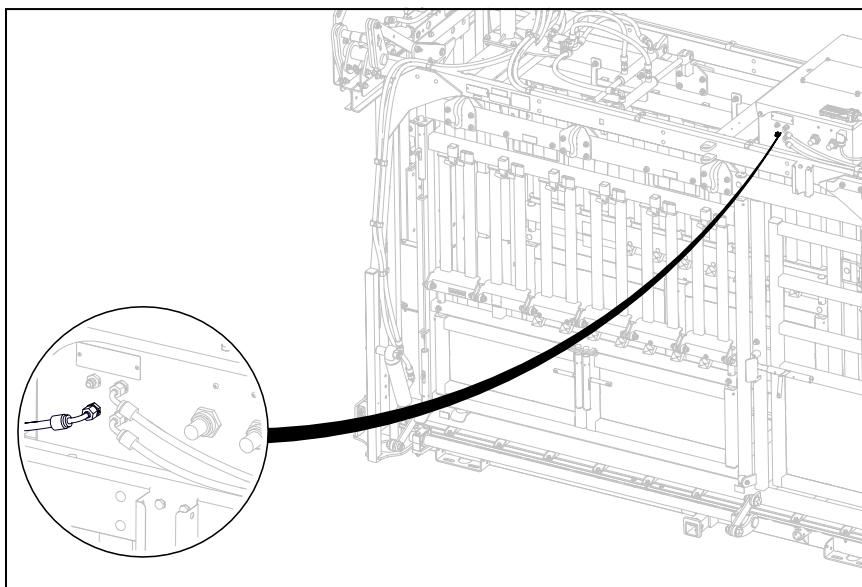

- b. Connect the 90° crimp end of army front jack rod hose (9000983) to the top front port on the jack box in the orientation shown.

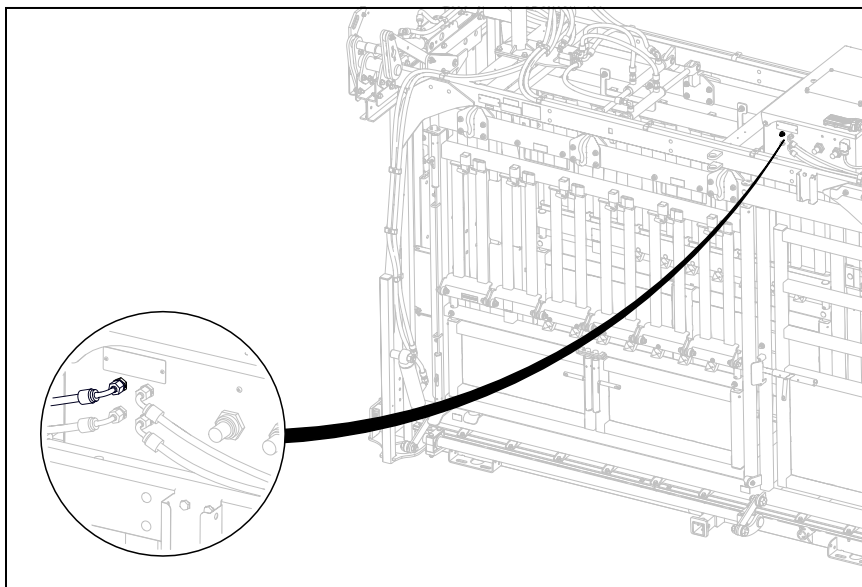

- c. Begin routing hoses, as shown, using hose clip (2017004) and preinstalled 1/4" thread cutting bolt (7003213) on top frame.

NOTE: Tighten enough to hold the hose but loose enough that you can adjust the amount of slack in the hose.

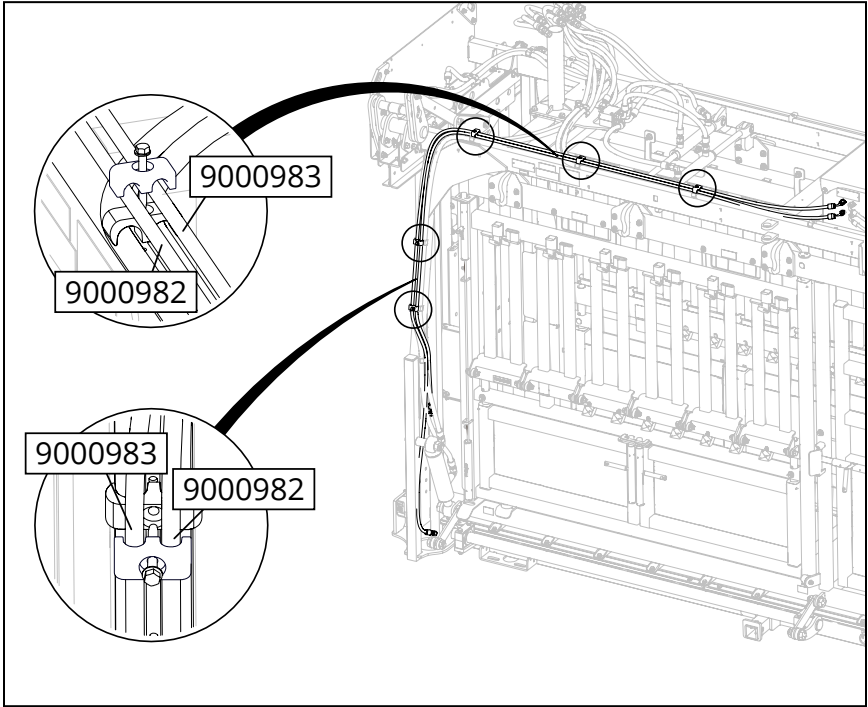

- d. Connect jack cap hose (9000982) to the cap side of the hydraulic jack and connect jack rod hose (9000983) to the rod side of the hydraulic jack, leave loose for bleeding.

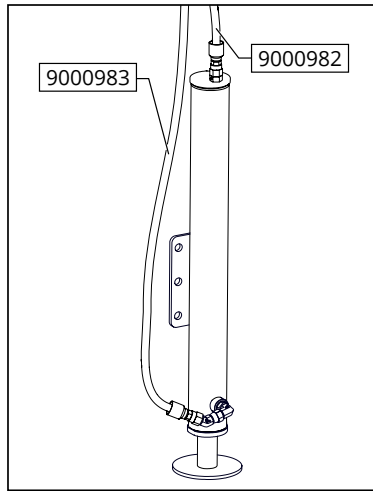

- e. Repeat on opposite side.
f. Jacks can be set aside, unmounted, at the front of chute until bleeding step.
9. Bleed hydraulic circuit

NOTE: This step will require two people. One to cycle the jacks and tighten the fittings, the other to stabilize the jacks as they are cycled up and down. Before filling reservoir make sure area around jack box is clean and there is no chance of contaminants entering the system.

- a. Fill reservoir in the Jack box with hydraulic oil.

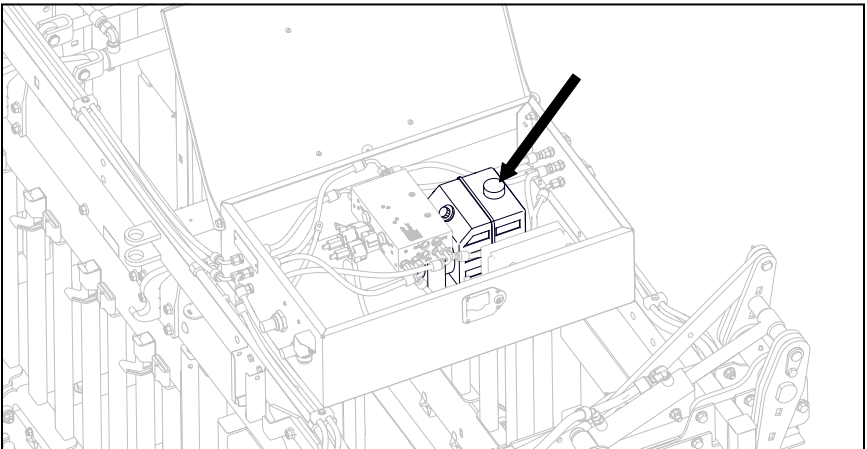

- b. Set battery charger to AGM/Deepcycle mode and 2amps. Connect the charger to the lugs on the side of the jack box.

NOTE: The jacks will be cycled many times and it is important to keep the battery topped up.

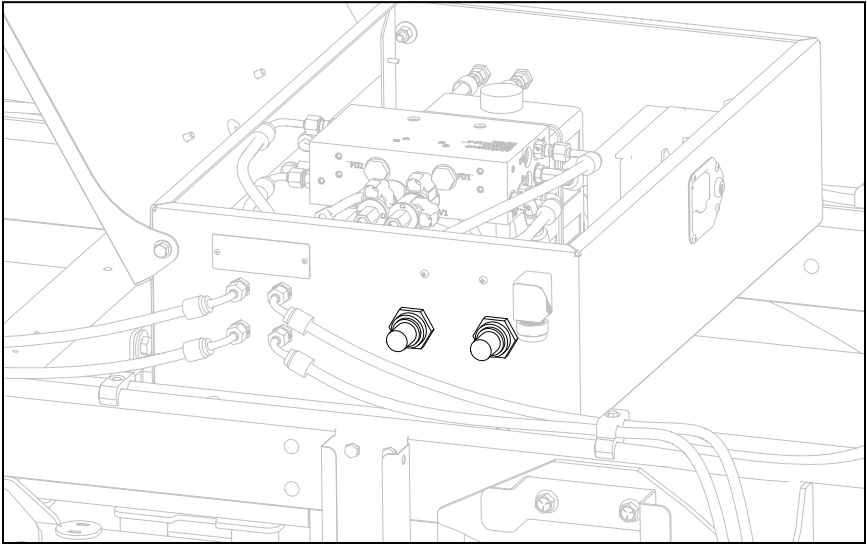

- c. Unravel pendant chord to give as much travel as possible.
- d. Front Jacks.
 - i. With top and bottom connections loose, press F↓ on the pendant until oil begins to come out of the cap side (top) of both jacks.
 - ii. Tighten cap side connection.
 - iii. Press F↓ on the pendant until both front jacks are completely extended.
 - iv. Press F↑ until hydraulic oil starts to come out of the rod side (bottom) connections of both jacks.
 - v. Rod side connection can now be tightened.
 - vi. Press F↑ until jack is completely retracted.
 - vii. Now that you have used the jacks, turn the battery charger from 2amps to 10amps.
 - viii. Extend jacks a few inches and apply weight to each jack. If the jack feels spongy, extend fully, retract fully then check again. Continue till jack feels firm as this will mean all the air has been evacuated.
 - ix. Refill reservoir in jack box.
- e. Rear Jacks.
 - i. Repeat bleeding procedure from the front jacks with rear jacks. Use buttons R↓ and R↑ on the pendant.

- f. Fill reservoir in jack box to fill line and tighten cap.
- g. Now that we have completed cycling the jacks, turn the battery charger from 10amps to 2amps. Leave until battery is fully charged.
- h. Pendant cable can be wrapped around pre-installed bracket and pendant can be placed in holder as shown.

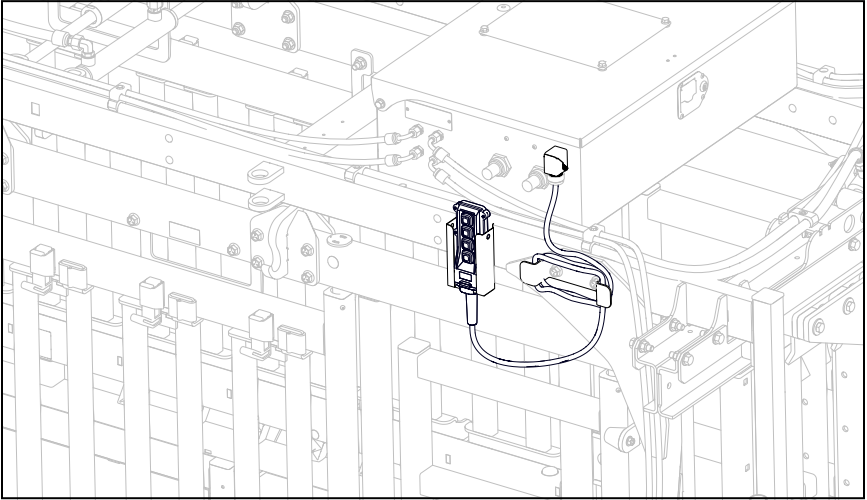

10. With top squeeze completely open, move the bottom squeeze inward about 1" to make the following steps easier.

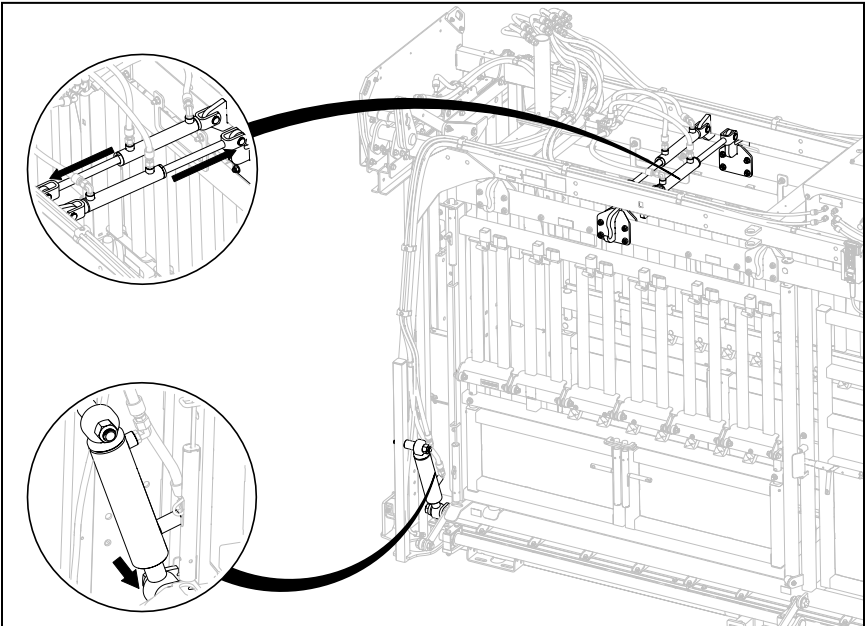

11. Remove the nut that holds the cap end of the bottom squeeze cylinder to the squeeze pivot point.

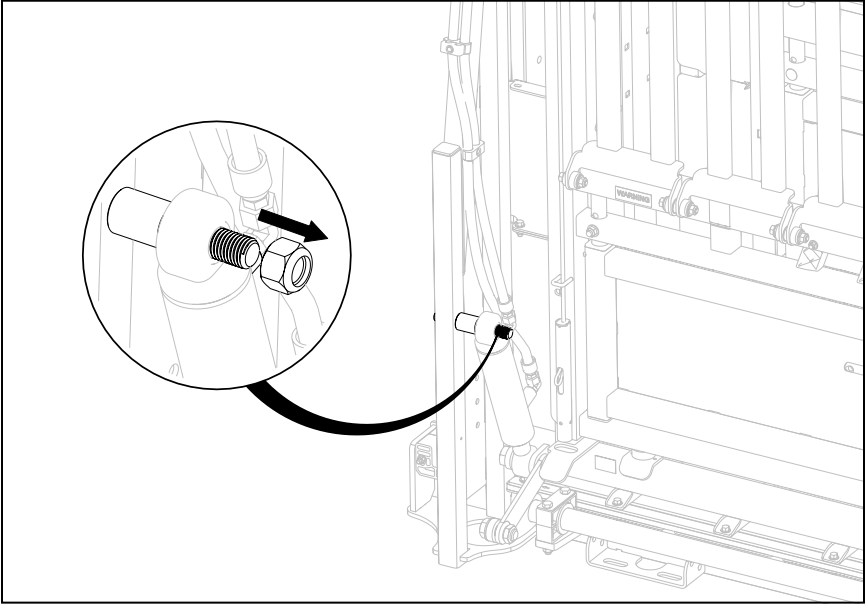

12. Remove hoses from bottom hose clip. This will allow enough space to install the jack.

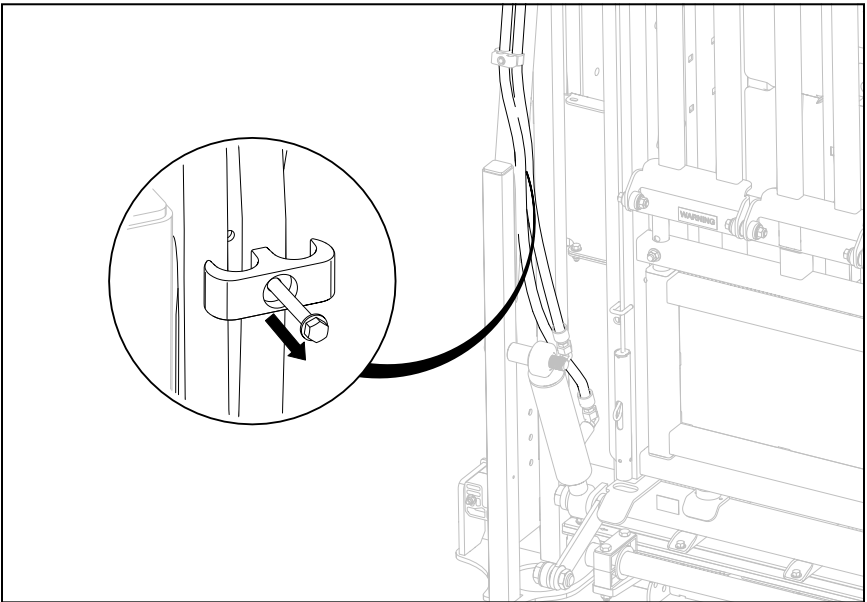

13. Remove cylinder from the squeeze pivot.

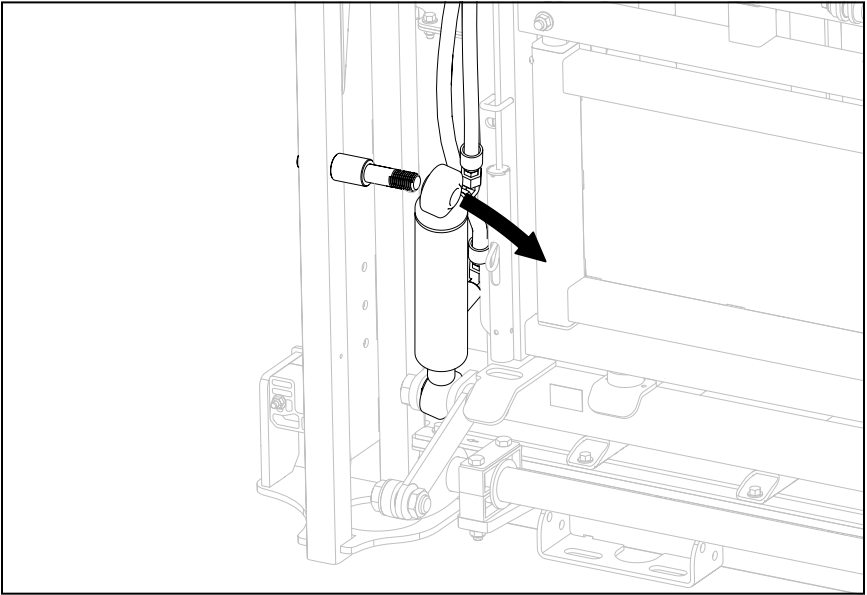

14. Install front jack as shown and fasten with 1/2" x 1.5" long flange head bolt (7003004) and nut (7003177).

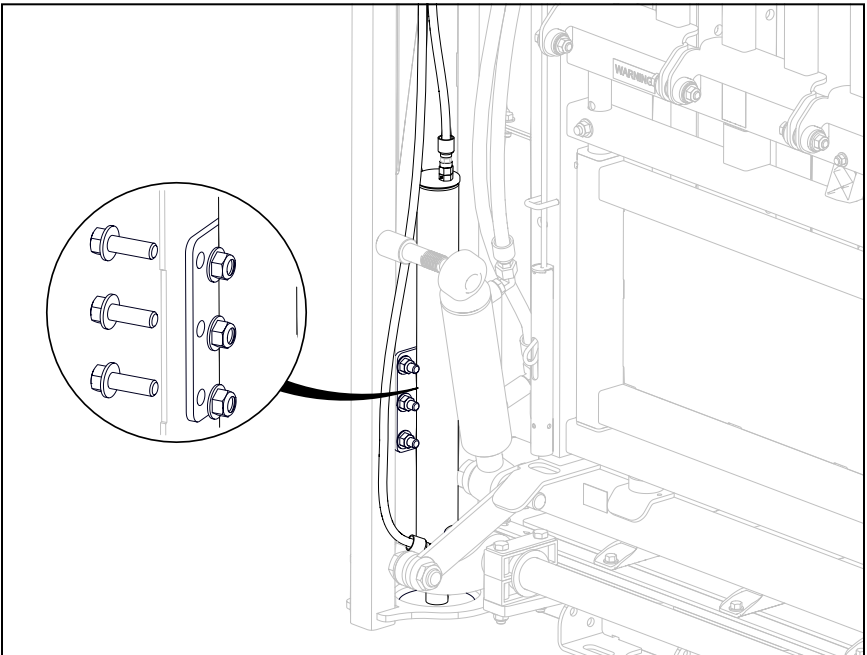

15. Reinstall squeeze cylinder on squeeze pivot and tighten nuts.

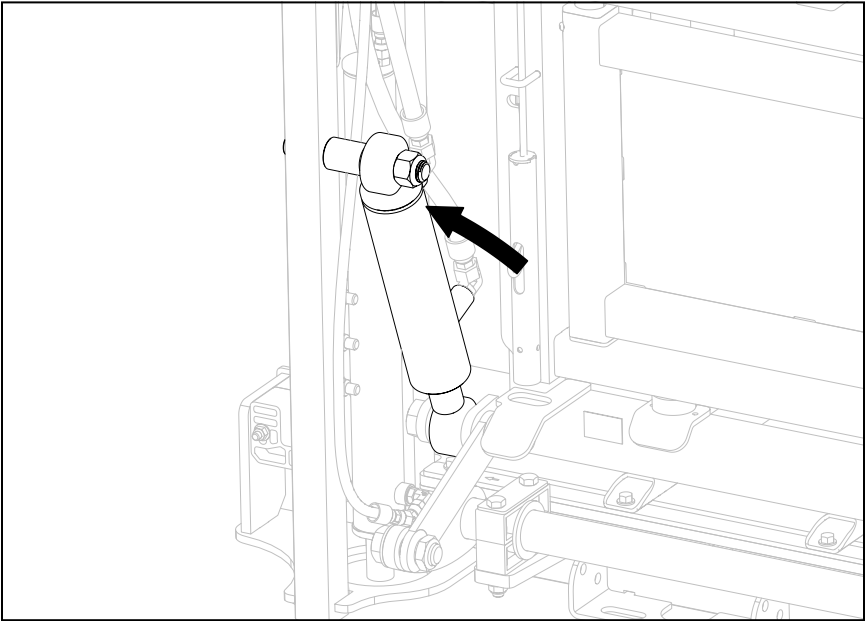

16. Install bottom hose clip (2017004) with 1/4" thread cutting bolt (7003213).

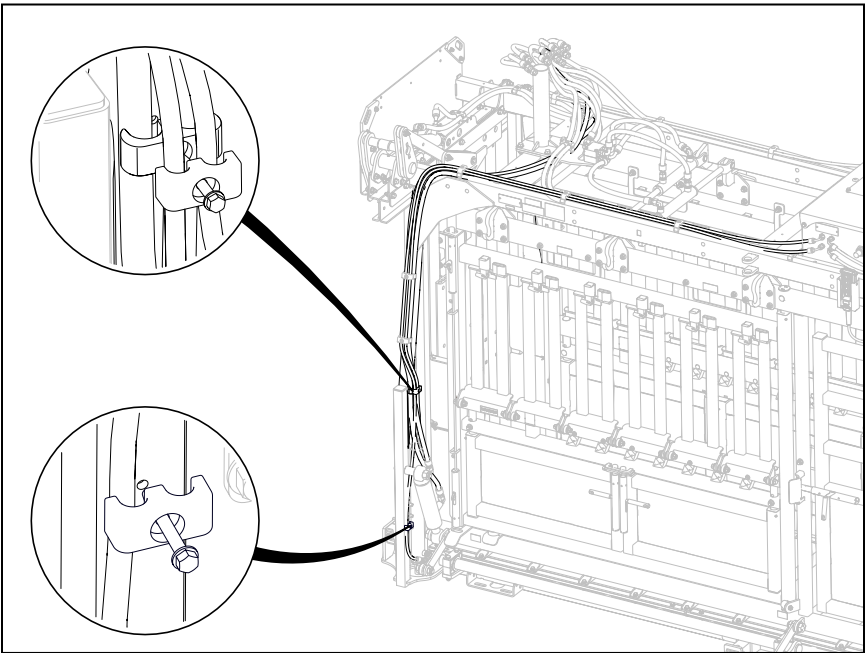

17. Repeat steps 11-16 on opposite side.

18. Move the bottom and top squeezes all the way in to provide access to the rear mount points.

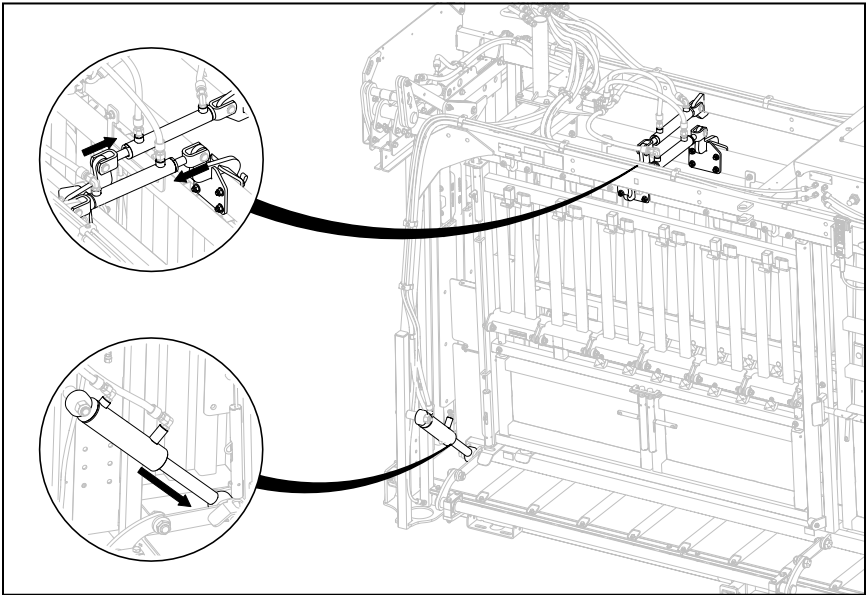

19. Install the rear jack as shown and fasten with 1/2" x 1.5" long flange head bolt (7003004) and nut (7003177). Repeat on opposite side.

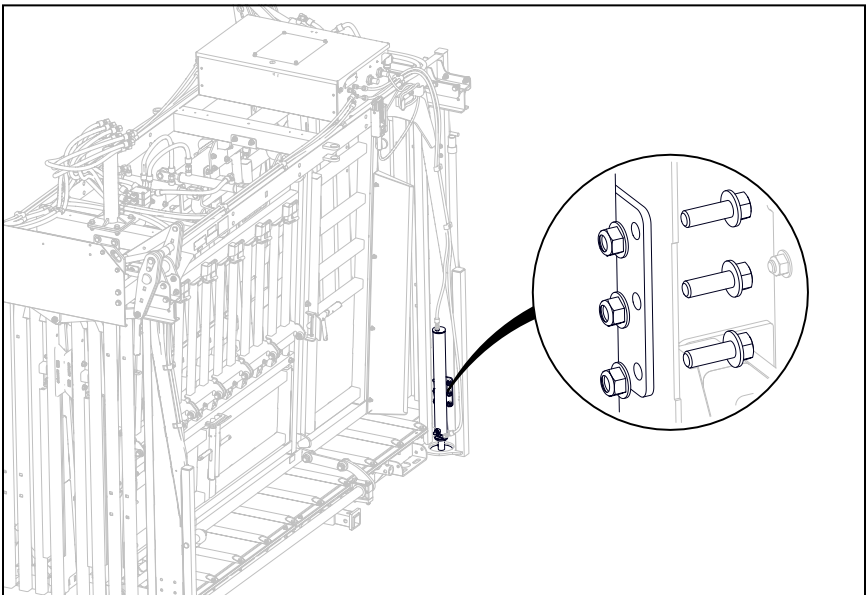

20. Bottom hose clip (2017004) can be installed with 1/4" thread cutting bolt (7003213) as shown on both sides.

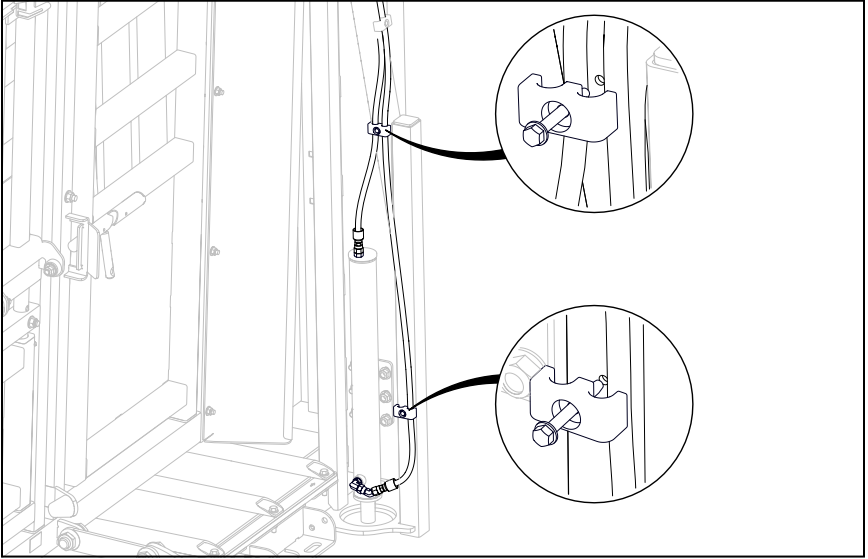

21. Move the slack in the hoses to ensure that excess hose length will not get caught on chute functions, block outs, head gate tracks and front bottom squeeze. Test all chute functions to ensure that no moving parts touch the hoses. When satisfied, hose clips can be tightened so hoses remain in place.

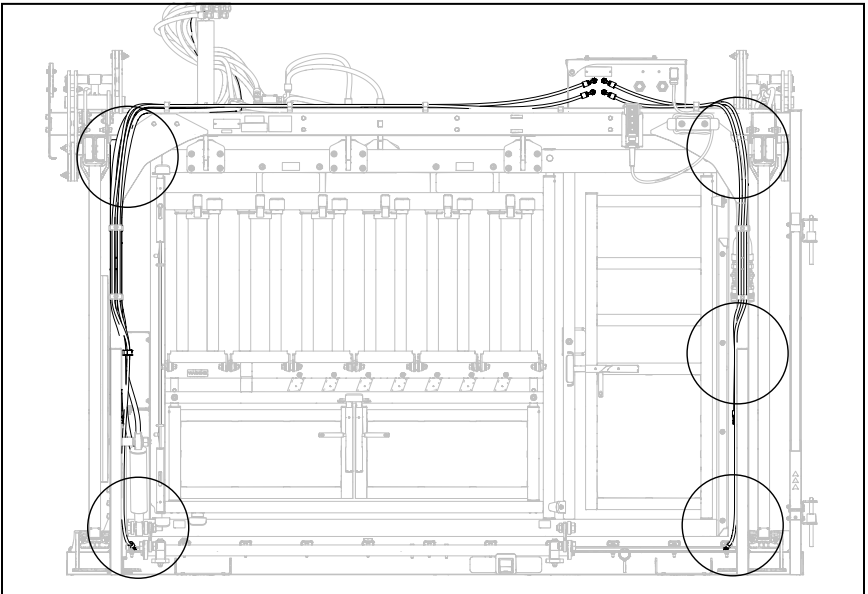

HYDRAULIC JACK MAINTENANCE

Keeping the battery charged in this system is important. If the left and right jacks are not lifting evenly this is a sign that the battery is low and must be charged with a 12V AGM/ Deep cycle battery charger.

The hydraulic jack box has a solar panel to maintain the battery charge. If the chute is kept in a low light area, consider buying a battery maintainer and leaving it permanently connected to the lugs on the jack box.

ARMY HYDRAULIC WHEEL KIT

NOTE: If your unit does not have the hydraulic jacks and jack box installed from factory refer to "**ARMY HYDRAULIC JACKS**" section for field installation instructions of the jacks.

OPERATING THE HYDRAULIC JACKS:

Refer to this guide to ensure safe operation of the Hydraulic Jacks.

- Arrowquip hydraulic jacks are run with a 4-button pendant with symbols: F↑, F↓, R↑, R↓.
- "F" for Front, "R" for Rear, and the "↑↓" arrows indicate which direction the foot of the jack will travel.
 - Ex. pressing F↓ will move the foot of the front jack down, lifting the front of the unit.
- When lifting or lowering the unit, alternate between front and rear jacks to maximize stability. Difference between rear and front chute height should not exceed 8".
- Only lift the unit when on firm level ground.
- Never raise the unit more than necessary to put on tires.
- If left and right sides are not lifting evenly do not continue lifting unit.
 - This indicates that the jack box battery is low and needs to be charged before unit will lift evenly.

If you have any questions, please contact Client Care at 1-877-275-6075 for assistance.

INSTALLATION:



THE CHUTE MUST BE FLAT ON THE GROUND BEFORE PROCEEDING.

1. Using the pendant control, lift the front of the chute 6"-8"

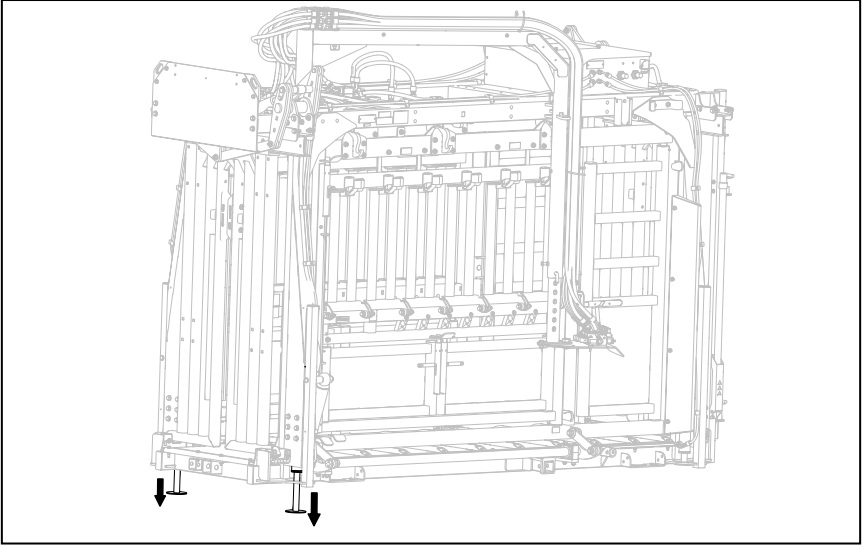

2. Lift the rear of the chute up 12"-16".

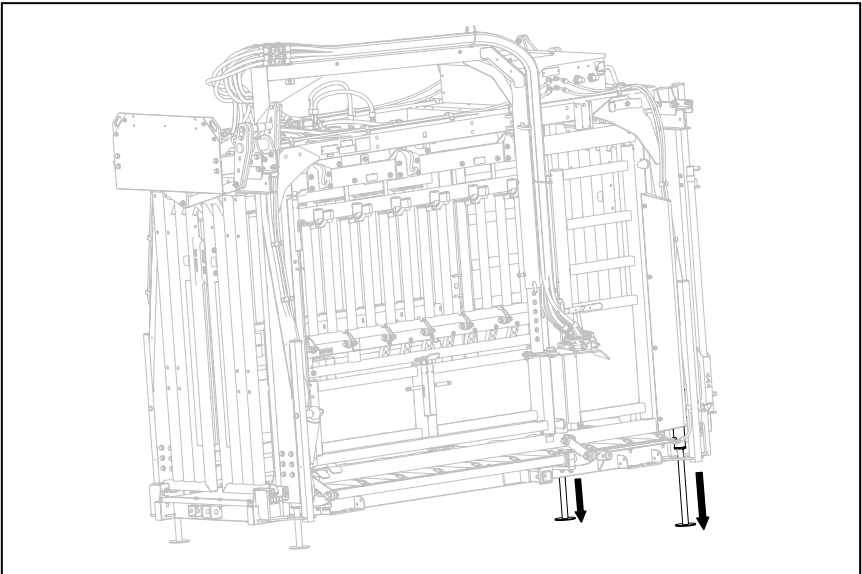

3. Continue to alternate lifting front and rear of the chute until it is high enough to install the wheels.
4. Install wheels in orientation shown and secure with transport pin.

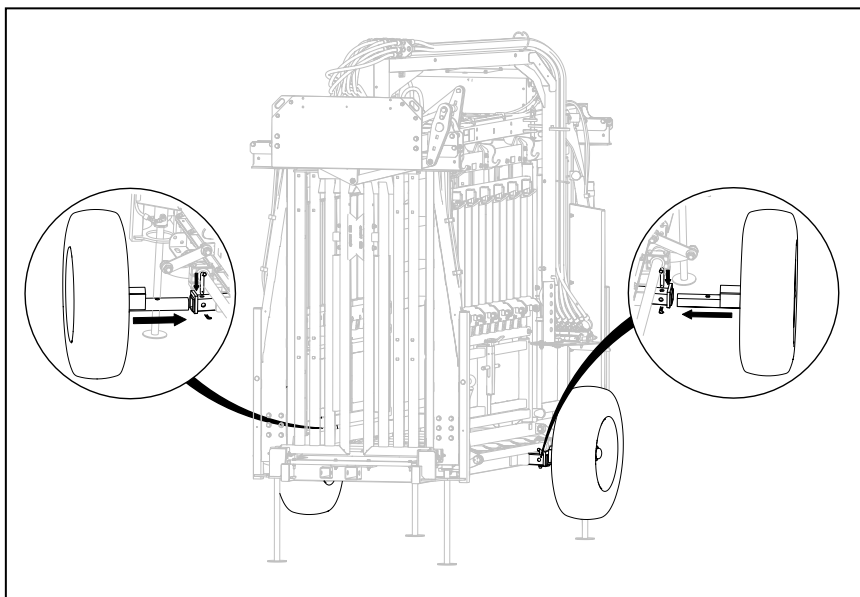

5. Install hitch.

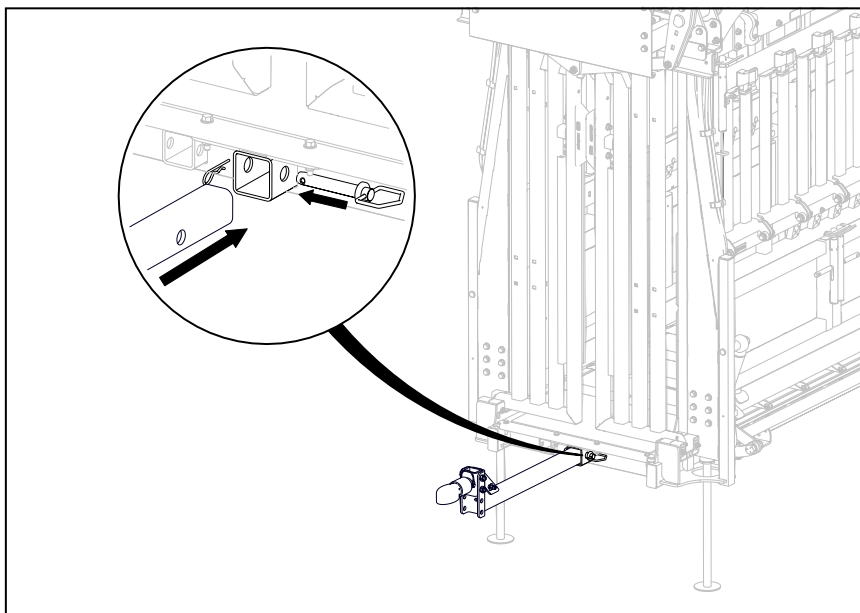

6. Use hydraulic jack controls to position hitch to attach to towing vehicle.

NOTE: Ensure safety chains provided have been attached to the unit.

7. Starting with the rear set, completely retract both sets of jacks.

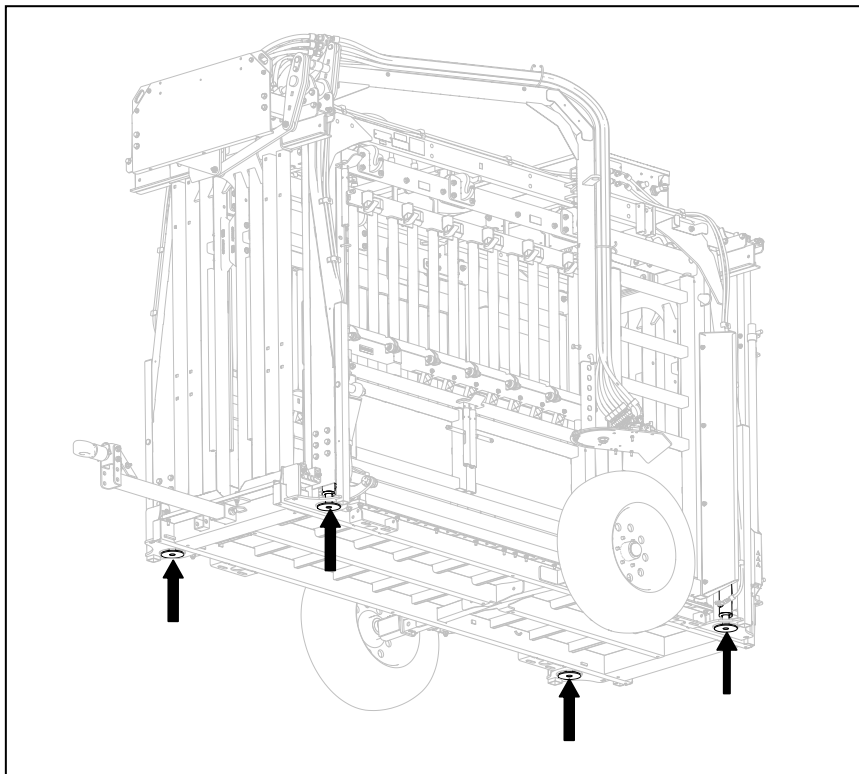

YOUR CHUTE IS NOW READY FOR TRANSPORT.

SAFETY CHECK:



- Jacks are retracted completely.
- Swing arm is pinned in transport position.
- All doors and gates are shut.
- Tires are in good condition.

MAXIMUM SPEED: 50 KPH / 30 MPH

REMOVAL:



ENSURE YOU ARE DISCONNECTING THE CHUTE ON FIRM, LEVEL GROUND BEFORE PROCEEDING.

1. Extend rear jacks until the feet touch the ground.

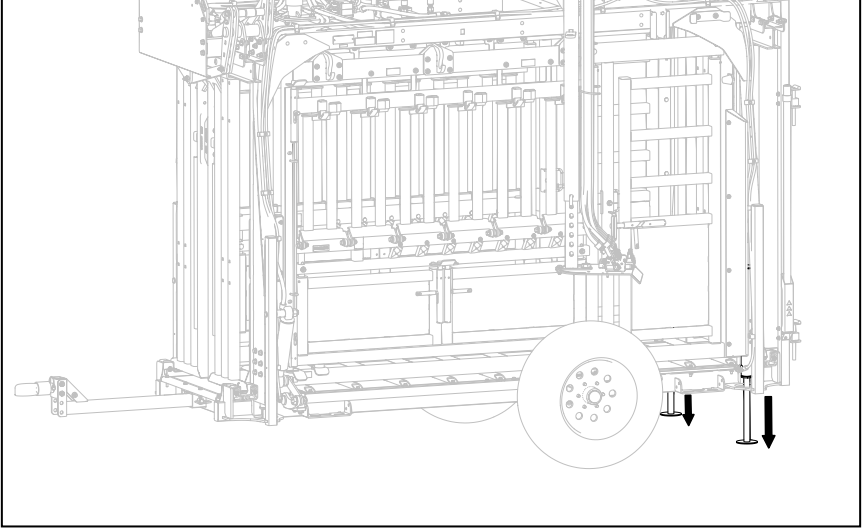

2. Extend front jacks until hitch is free from the towing vehicle and disconnect.

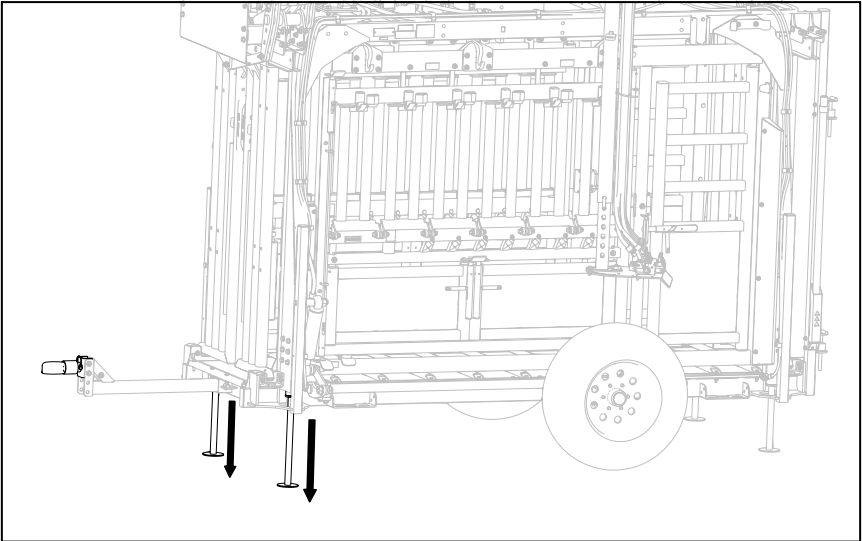

3. Continue to alternate between extending the front and rear jacks until the tires are clear of the ground.
4. Remove hitch and set aside.

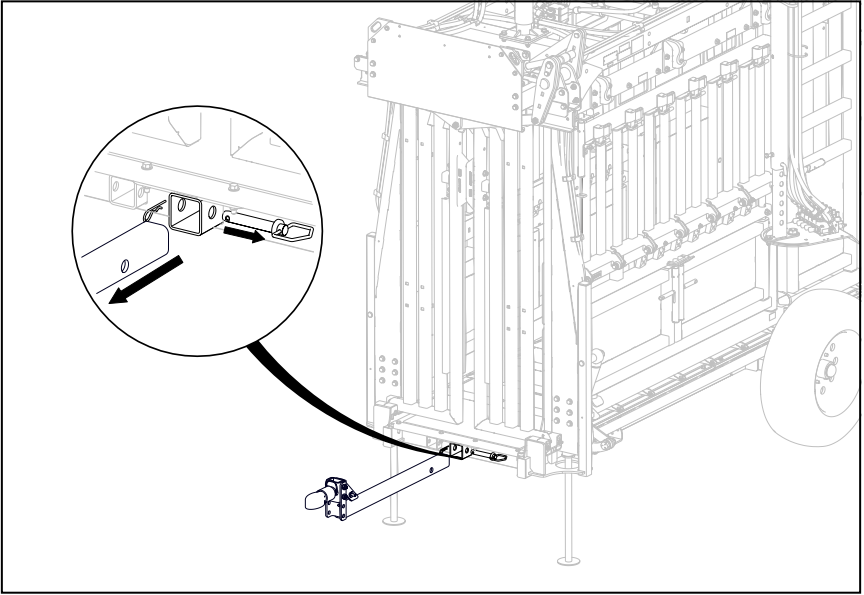

5. Remove wheels and set aside.

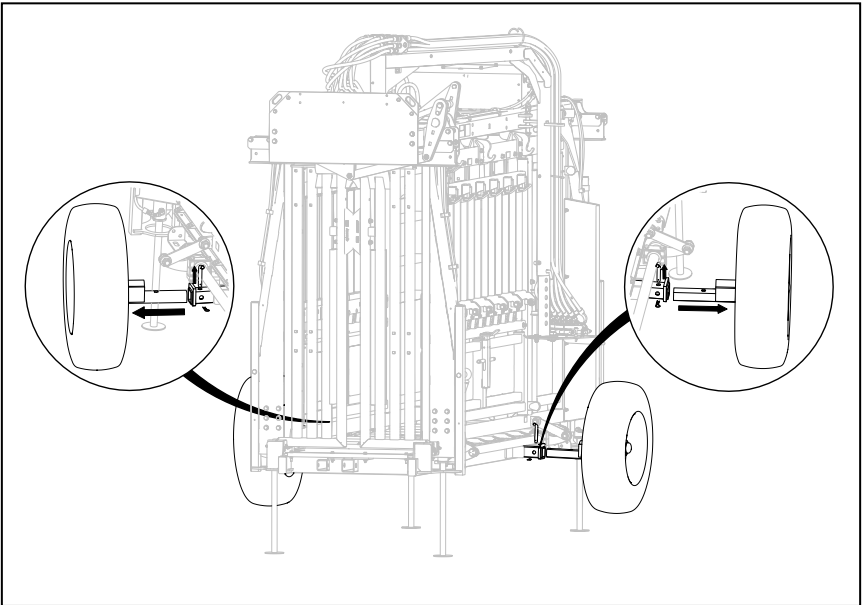

6. Alternating between front and rear, retract the jacks until completely retracted and chute is resting flat on the ground.

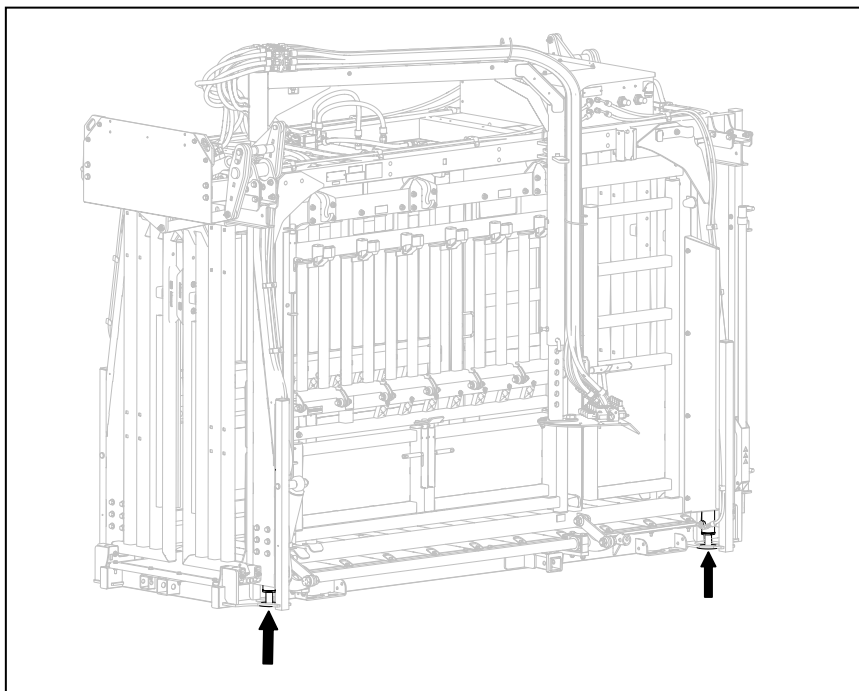

SAFETY CHECK:



- Ensure chute is stable.
- Inspect for damages due to transport.
- Head gate and squeeze mechanisms are functioning properly.
- All latches on doors, gates, and panels are functioning properly.
- When applicable, all add-ons are properly installed and functioning.

WHEEL MAINTENANCE

Hydraulic Jacks:

The following can be checked between 10 uses or bi-annually.

- Check that hydraulic oil in reservoir is up to the fill line on the tank.
 - Ensure surrounding area is clean when topping up hydraulic oil to ensure contaminants do not get added to the system.
 - Ensuring hydraulic oil is at fill line prevents condensation from entering the system which can be catastrophic.
 - The unit requires 6L of 22 AW Hydraulic oil
 - If this oil cannot be found, use the lightest hydraulic oil available in your area.
- Check that fittings on jacks are tight and not leaking.
- Clean solar panel to ensure peak performance.

Battery:

Specs:

- Size: U1
- Type: AGM, Sealed Lead Acid
- Capacity: 35Ah
- Voltage: 12V

A low battery can cause syncing issues between left and right jacks causing unstable lifting scenarios.

- The jack box is equipped with external positive and negative lugs for charging or running jacks off a vehicle in emergency situations.

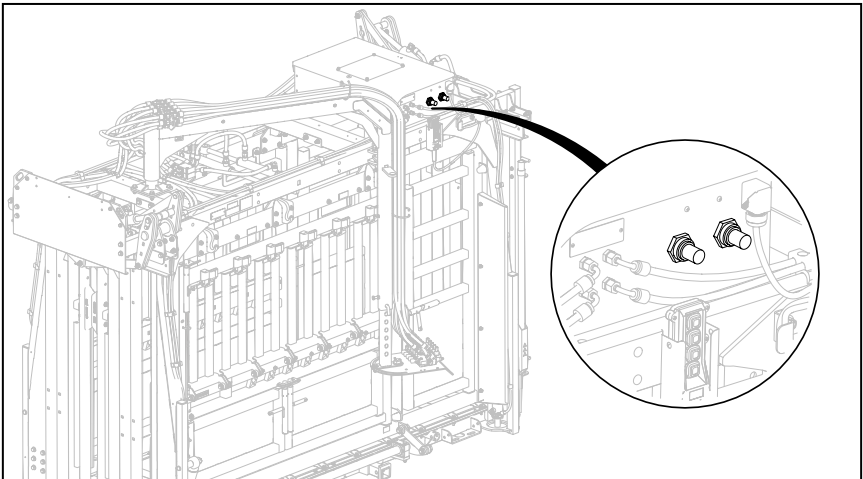

- Use a 12Volt charger set to AGM/Deepcycle mode to charge jack battery.

Tire Pressure:

The pressure in the tires from factory will be around 80 PSI.

For an improved towing feel reduce air pressure to recommended value depending on the product:

- **ARROWLOCK AND POWERLOCK CHUTES:** 40 PSI
- **ARMY SERIES CHUTES:** 50 PSI

Torque:

Lug nuts should be tightened to 120 ft. Lbs.

A torque wrench is recommended to make sure fasteners are tightened properly.

Be sure to use only fasteners matched to the cone angle of your wheel – usually 60° or 90°.

To properly attach wheels:

1. Start all bolts or nuts by hand to prevent cross-threading.
2. Spin lug nuts all the way down until rim is seated against the wheel hub. Tighten lug nuts to 120 ft. lbs. in cross sequence as shown below.









3. Torque the wheel nuts/bolts before first road use and after each wheel removal. Check and re-torque after 50 miles. Check periodically thereafter.

HYDRAULIC NECK EXTENDERS

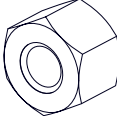
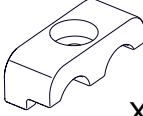
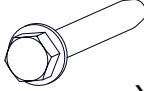
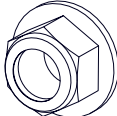
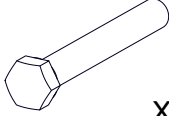
REQUIREMENTS:

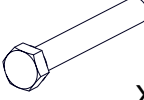
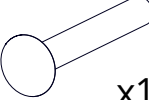
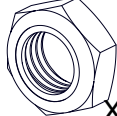
- 2 people
- 2 x Punch or Prybar
- Wrenches/Sockets:
 - 2 x 7/16"
 - 1/2"
 - 2 x 9/16"
 - 2 x 3/4"
 - 7/8"
 - 11/16"
 - 2 x 1-1/2"

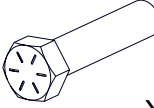
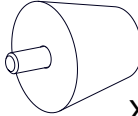
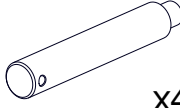
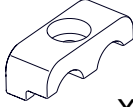
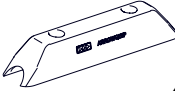
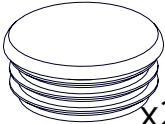
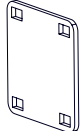
USER ASSEMBLY PARTS LIST

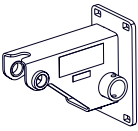
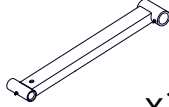
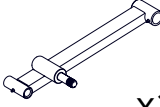
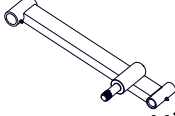
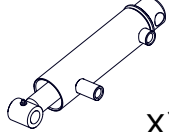
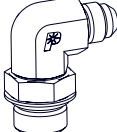
7002102 NUT-NYL-0.25-20-Z-5  x3	7003006 BOLT-HH-0.250-20-1.75-Z-5-FT  x3	7003213 THRD-CUT BOLT Z 1/4-20X2" TFL  x2	7003178 NUT-FNYL-0.375-16-Z-5  x4
7003183 BOLT-HH-0.375-16-2.75-Z-5  x4	7003177 NUT-FNYL-0.5-13-Z-5  x24	7002286 BOLT-HH-0.5-13-3.5-Z-5  x8	7002100 BOLT-CAR-0.5-13-3.5-Z-5-FT  x16
7002871 NUT-NYLLP-1-8-Z-2  x12	7002803 SPRING WASHER Z 1"  x4	7002813 BOLT-HH-1-8-4.5-Z-8  x2	7002810 NE PIVOT PIN  x2
2011377 NE PIVOT PIN  x4	2017006 3/8 INCH DOUBLE HOSE CLIP  x10	2017711 14" NECK YOKE  x4	2030381 RND PLASTIC CAP 1.49"-1.58" ID  x2
2025604 NECK EXTENDER CLAMP PLATE  x2	2037543 ARMY-NEV2 TOP BACK PLATE BLK  x2	2037538 ARMY-NEV2 BOTTOM MOUNT - BLK  x2	2037544 ARMY-NEV2 TOP MNT LH - BLK  x1
2037546 ARMY-NEV2 TOP MNT RH - BLK  x1	2036331 NECK EXTENDER BOTTOM LINK WA  x2	2036332 NE CYL LINKAGE WA LH  x1	2036334 NE CYL LINKAGE WA RH  x1
2037547 ARMY-NEV2 POST W/A - BLK  x2	9000870 MASTER RPHAS CYL 2.5 X 6 ST  x1	9000869 SLAVE RPHAS CYL 2 X 6 ST  x1	9000232 08-06 M ORB-JIC 90 ELBOW  x4
9000911 ARMY NE MASTER/SLAVE CYL HOSE x1	9000912 ARMY NE MASTER CYL HOSE x1	9000913 ARMY NE SLAVE CYL HOSE x1	

INSTALLATION:

NOTE: Instructions are shown on an Army Series General. The process is the same for all compatible chutes.

1. Identify and sort right- and left-hand components.
 - a. Neck Extender top mounts are not reversible, when laid on the ground the left and right top mounts can be identified as seen below.

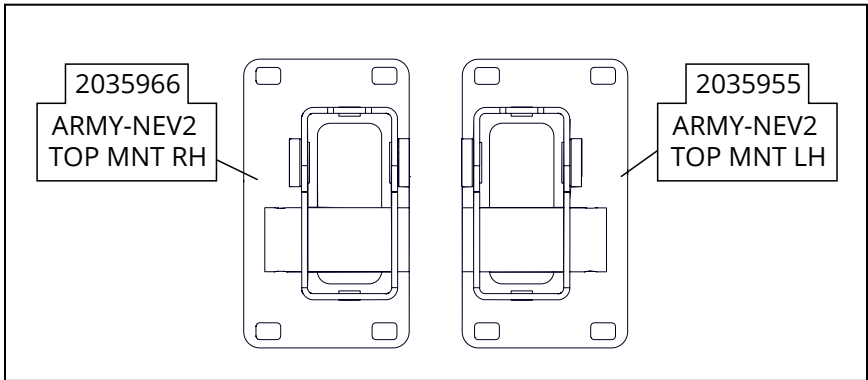

- b. When laid on the ground side by side, the right- and left-hand linkages can be identified as shown below.

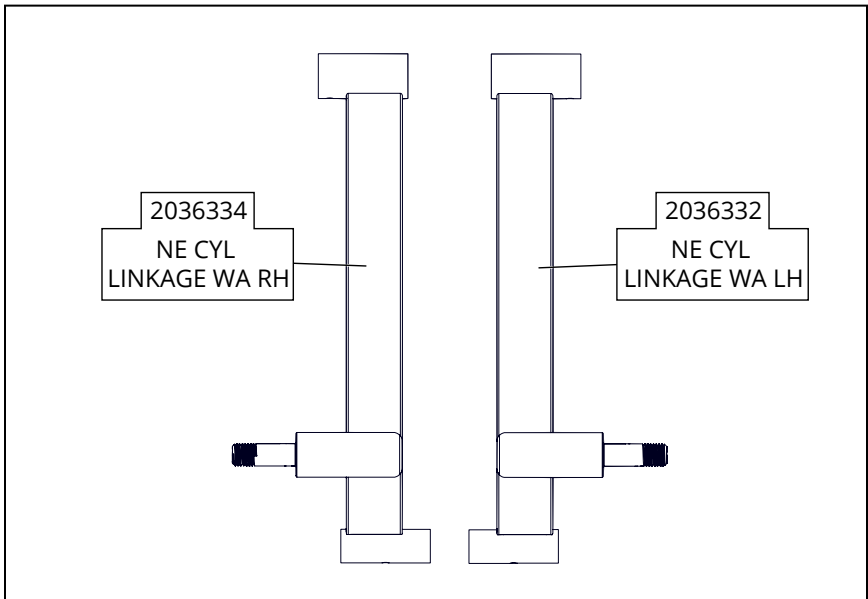

2. With head gate doors closed, install top clamp plates (2035957) and bottom clamp plates (2025604) with 1/2" x 3.5" carriage head bolts (7002100) on the backside of the doors in the four locations shown.

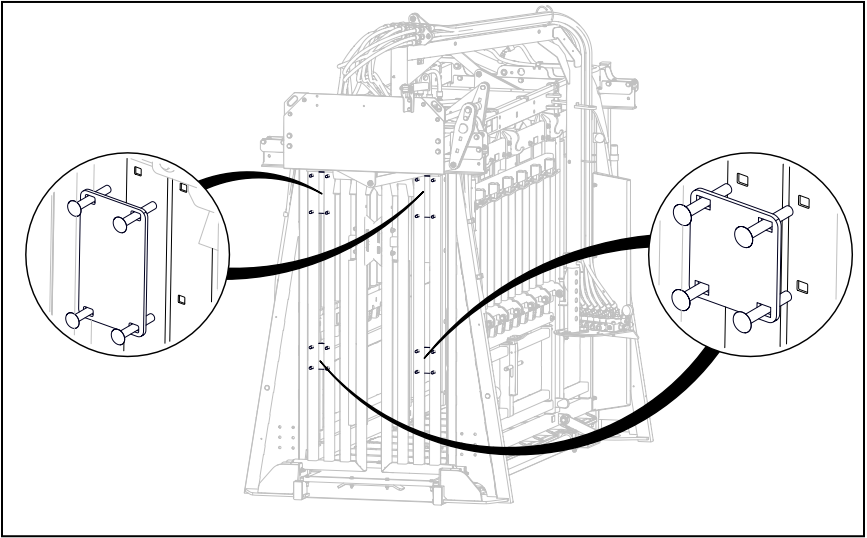

3. With head gate doors open, install neck extender bottom mounts (2037538) in bottom location as shown and fasten with 1/2" nut (7003177).

NOTE: Do not tighten all the way as this will make further assembly easier.

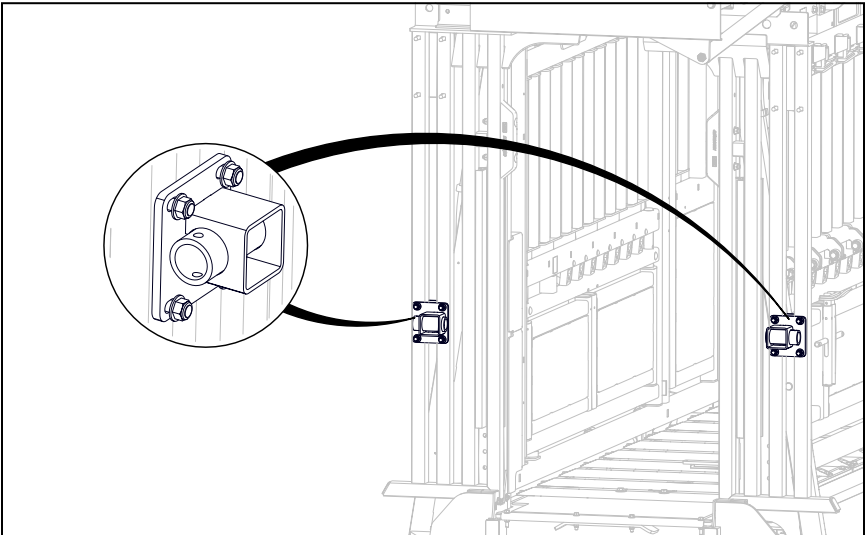

4. Install neck extender top mounts. Use part (2037544) on the LH door and part (2037546) on the RH door. Fasten with 1/2" nuts (7003177).

NOTE: Do not tighten all the way.

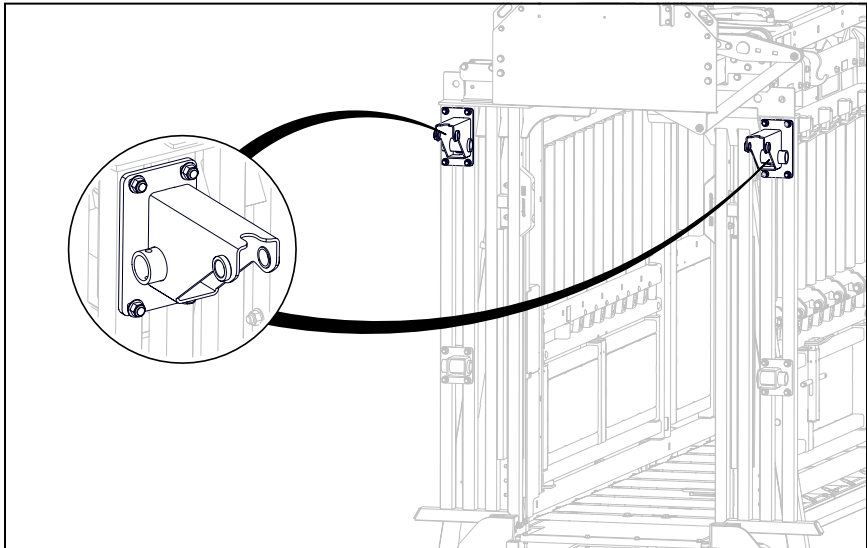

5. Install the neck extender pivot pins (2011377) into the four neck extender mounts as shown. Fasten with 3/8" x 2.75" long bolt (7003183) and nut (7003178).

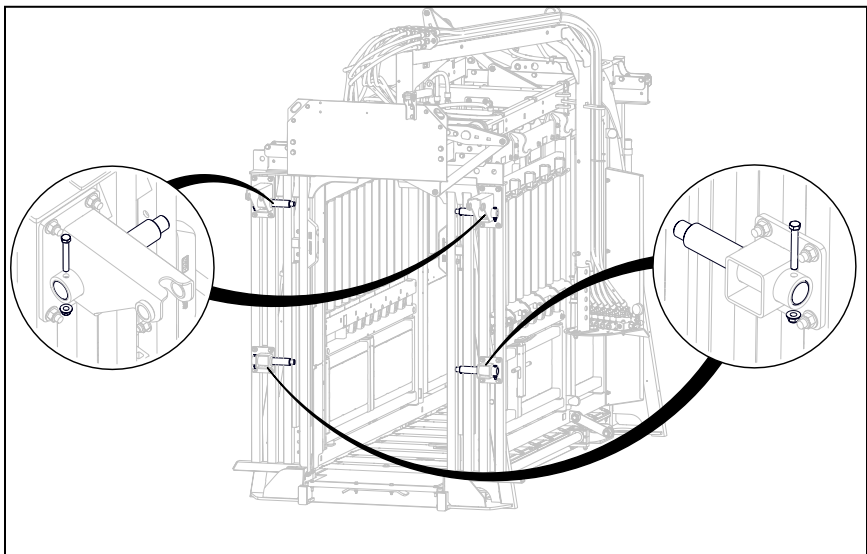

6. Install rubber bumpers (7002810) into threaded nutsert in both bottom linkages (2036331).

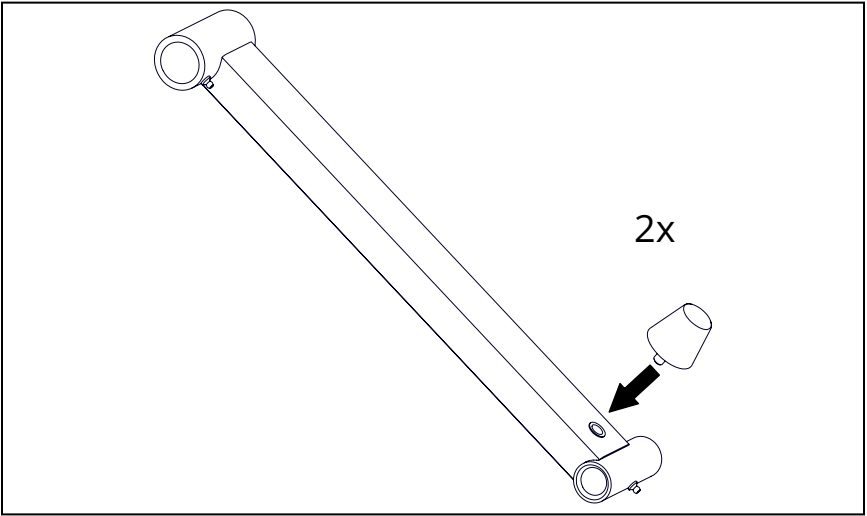

7. With the rubber bumper facing towards the door, install the bottom linkage as shown and install spring washer (7002803) and 1" nut (7002871) by hand. Do not tighten. Repeat on opposite door.

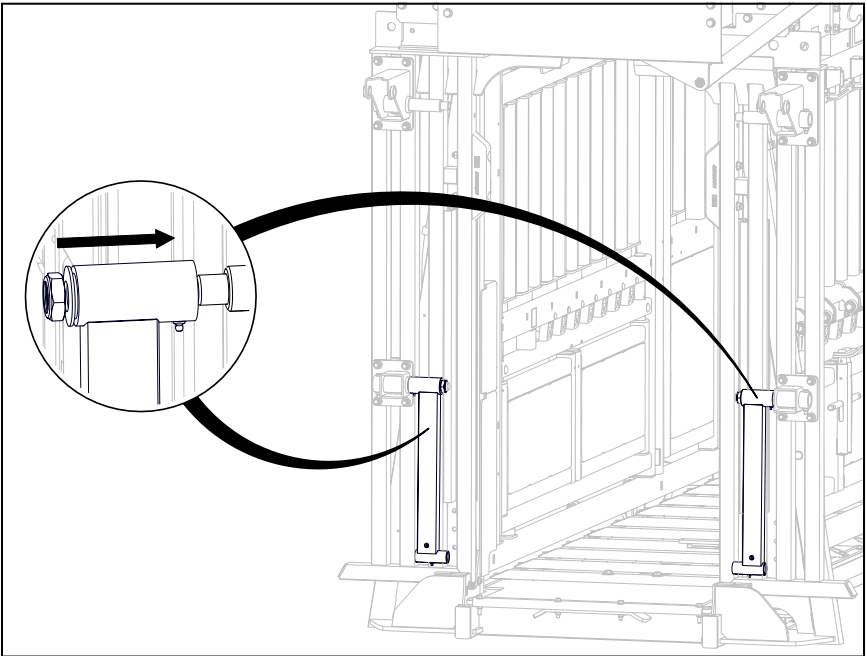

8. Install LH top linkage (2036332) as shown. Install spring washer (7002803) and 1" nut (7002871) by hand. Spring washer should have convex side facing out. Repeat on opposite door with RH Linkage (2036334).

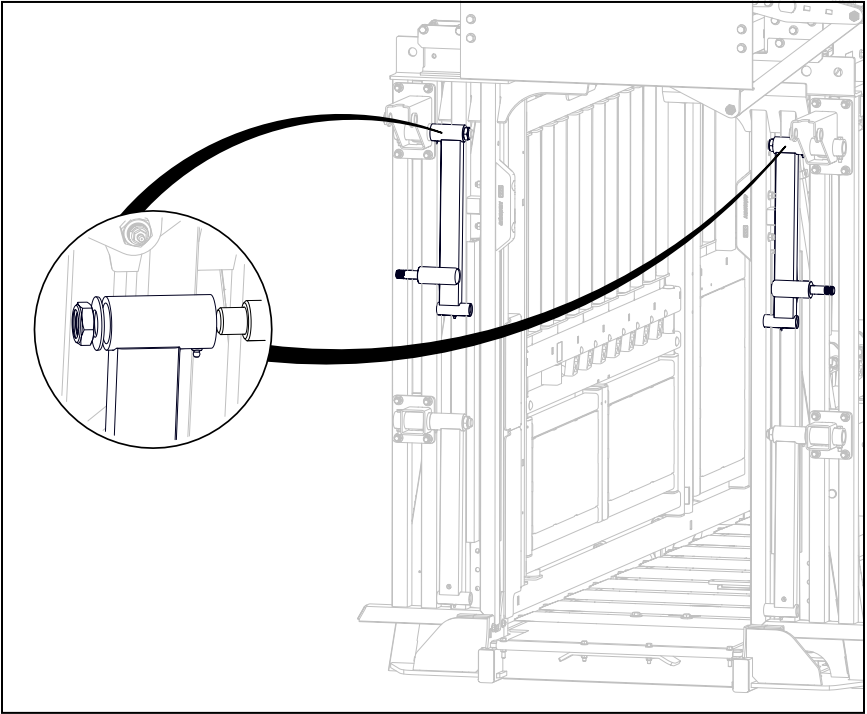

9. Sub-assemble neck extender posts by installing the following to weldments (2037547).
- a. Install tube cap (2030381).

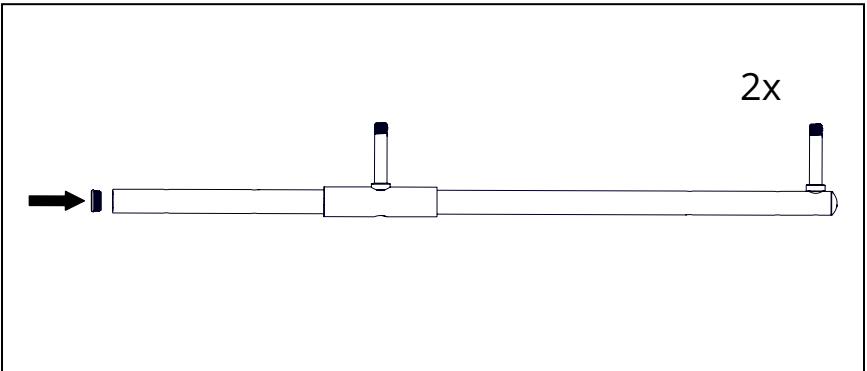

- b. Install top and bottom neck yokes (2017711) with 1/2" x 3.5" long bolt (7002286) and nut (7003177).

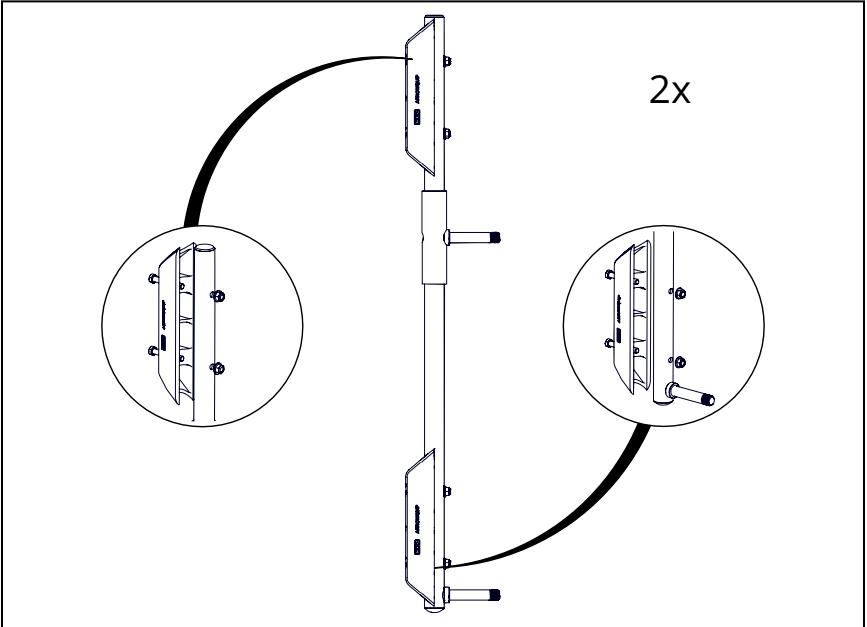

10. Install sub-assembled neck extender post into top and bottom linkages. Fasten with 1" nuts (7002871) by hand.

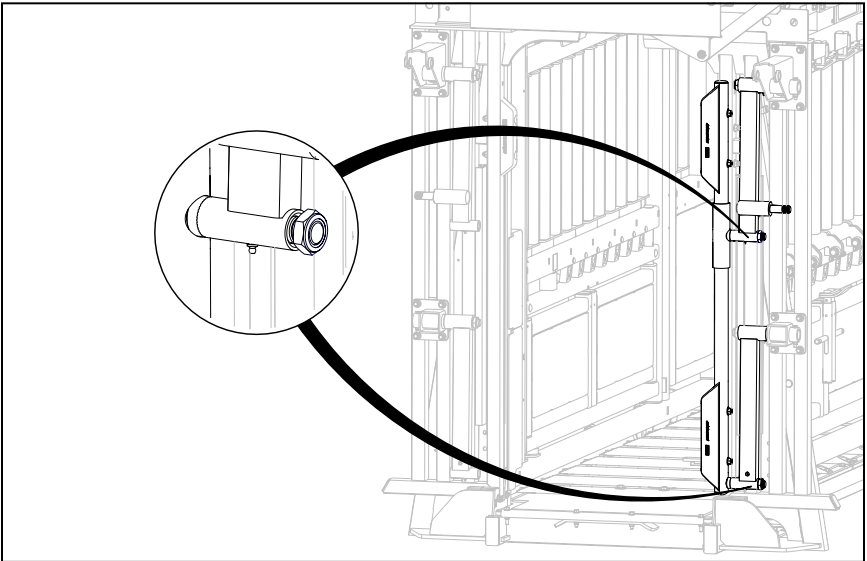

11. Remove factory plugs from cylinders (9000870) and (9000869). Using a punch or prybar to stick the tools through the rod and cap end. With a helper, pull the cylinder into its extended position. Note: Oil may come out of the ports.

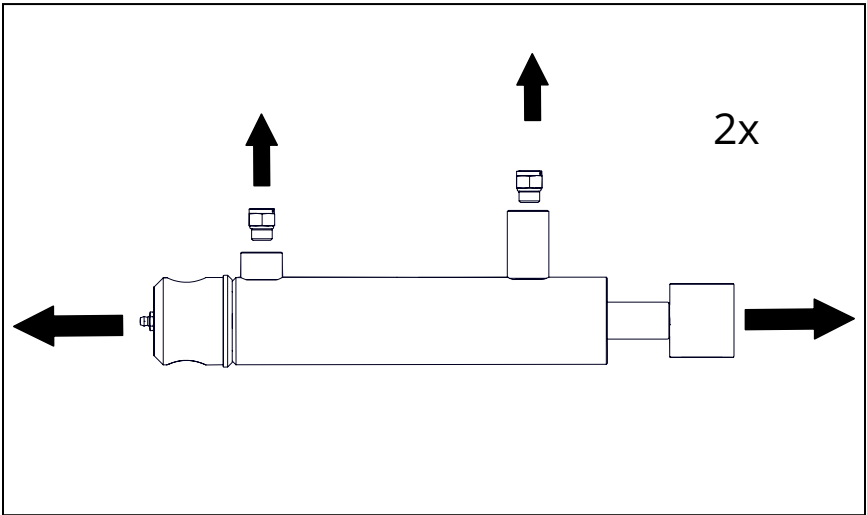

12. Install rod end of Master Cylinder (9000870) onto the **LHS** linkage as shown. Hand fasten with 1" nut (7002871).

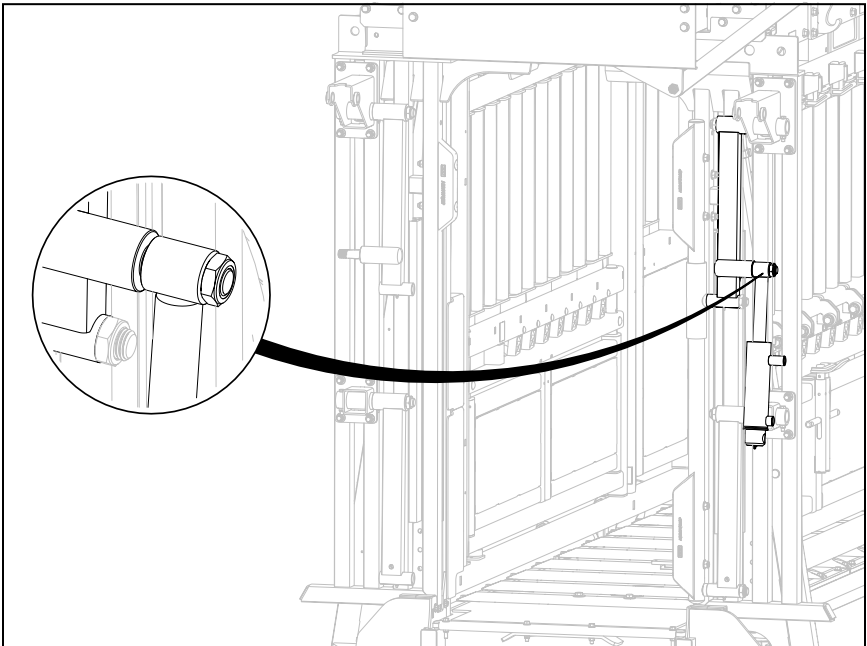

13. Rotate cylinder upward and fasten cap side to top neck extender mount using 1" x 4.5" bolt (7002813) and nut (7002871).

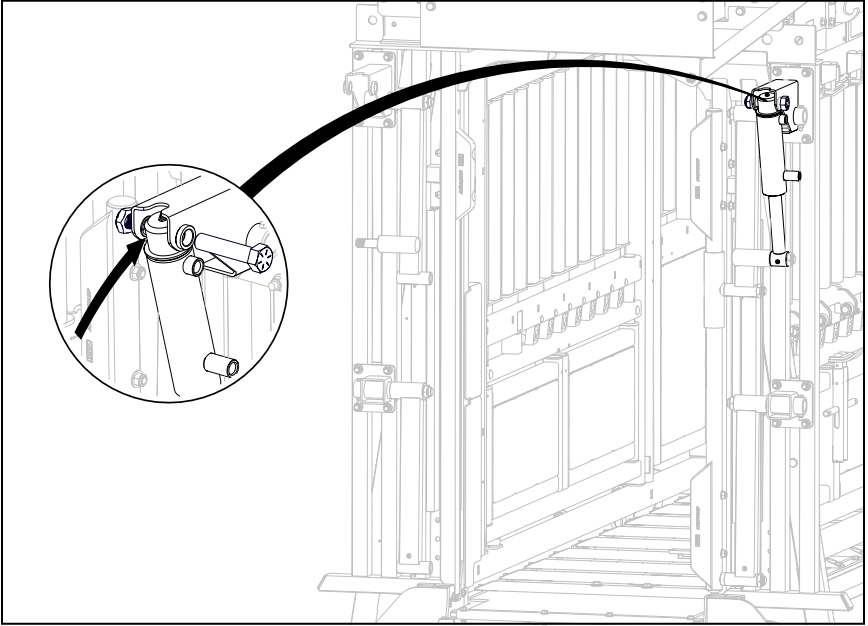

14. Repeat steps 10-13 for RHS with slave cylinder (9000869).

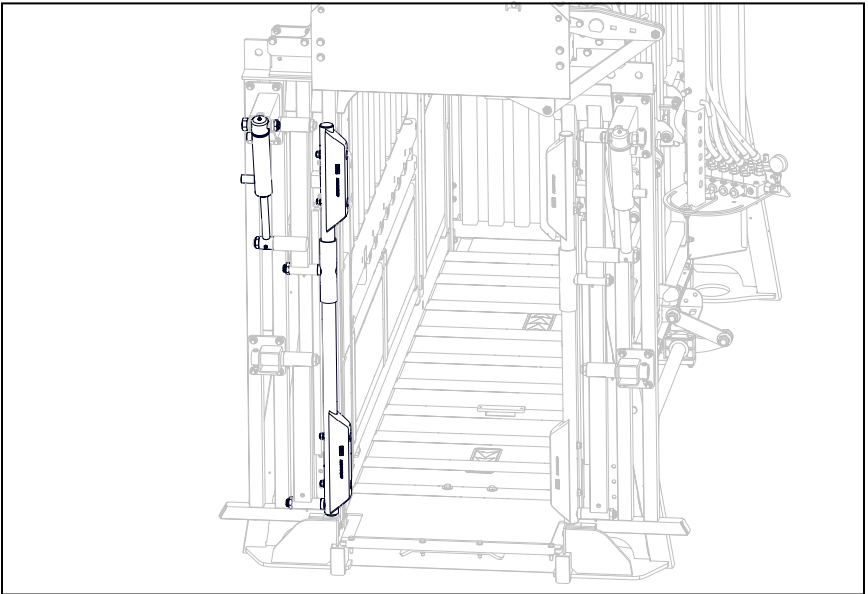

15. Now that all the mechanical components are completely assembled, all ten 1" nuts can be tightened.

NOTE: Do not overtighten joints so Neck Extenders can still pivot.

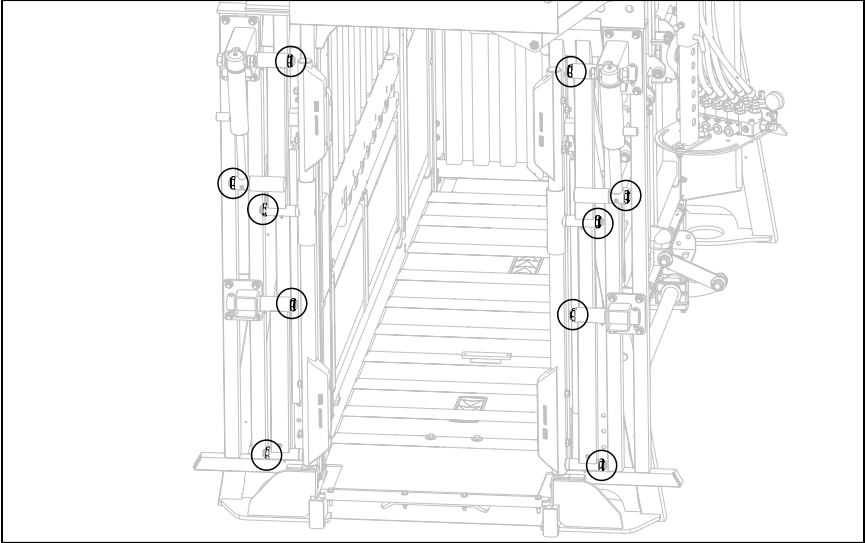

16. Neck extender mounts are slotted. For best neck extender performance: ensure that both top and bottom mounts are pushed towards the center of the chute when tightening the hardware. Neck extender mount hardware can be tightened in 16 places.

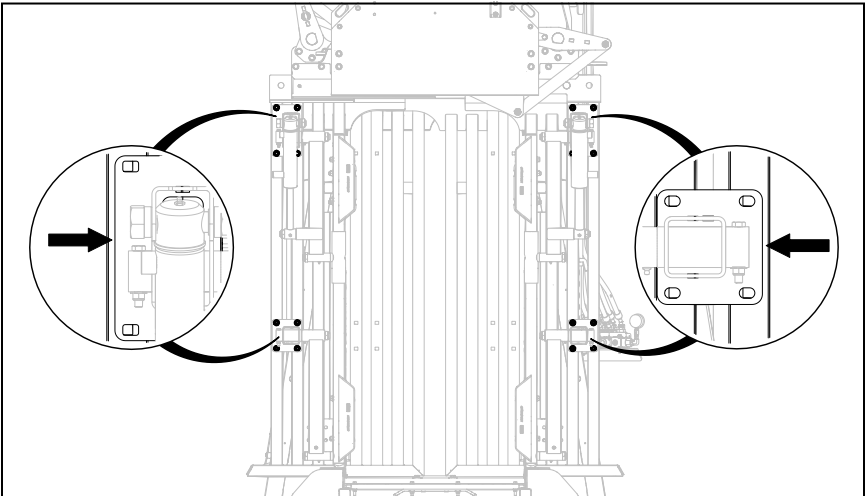

17. With head gate doors brought in, install fittings (9000232) into the neck extender cylinder and lock them in the orientation shown.

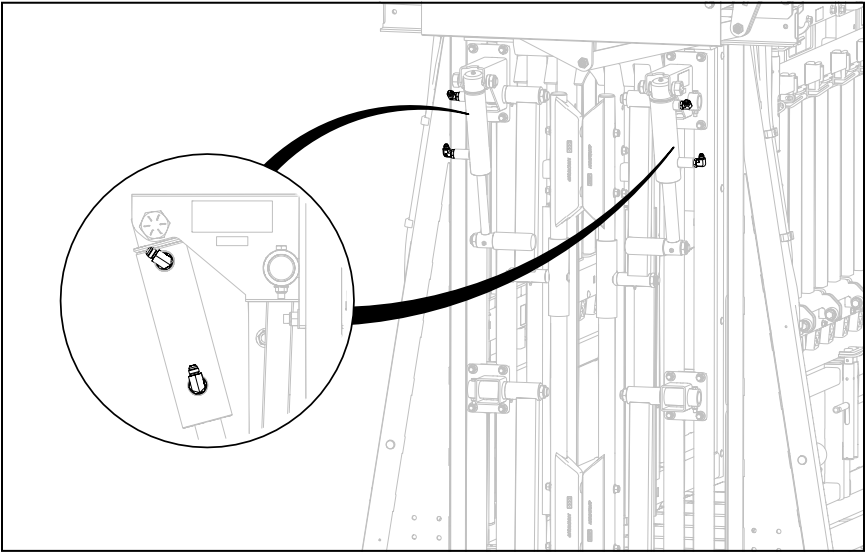

- 18.
- a. Connect hose (9000911) to the rod side of the LH master cylinder.
 - b. Route through head gate shield.
 - c. Then connect to the bore side of the RH slave cylinder.

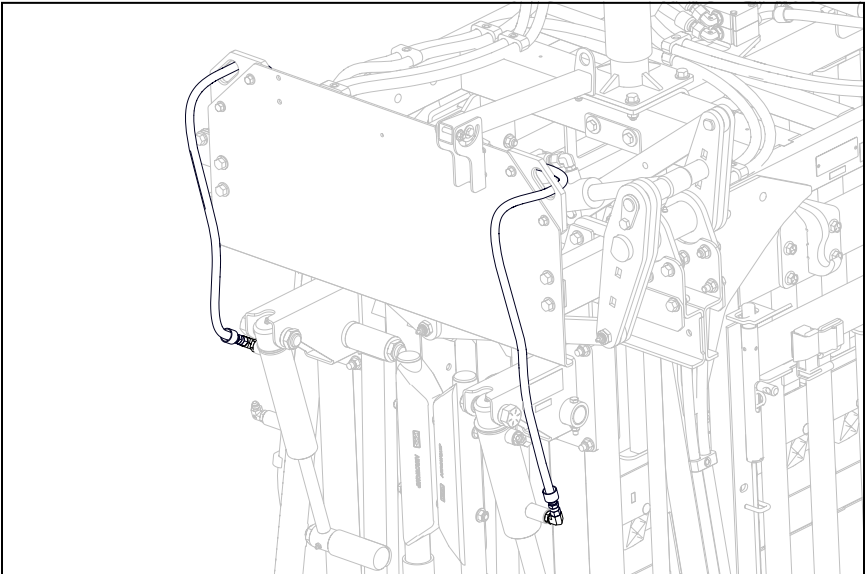

19. Remove caps from auxiliary functions on bulkhead.

NOTE: Some oil may come out of the bulkhead connections.

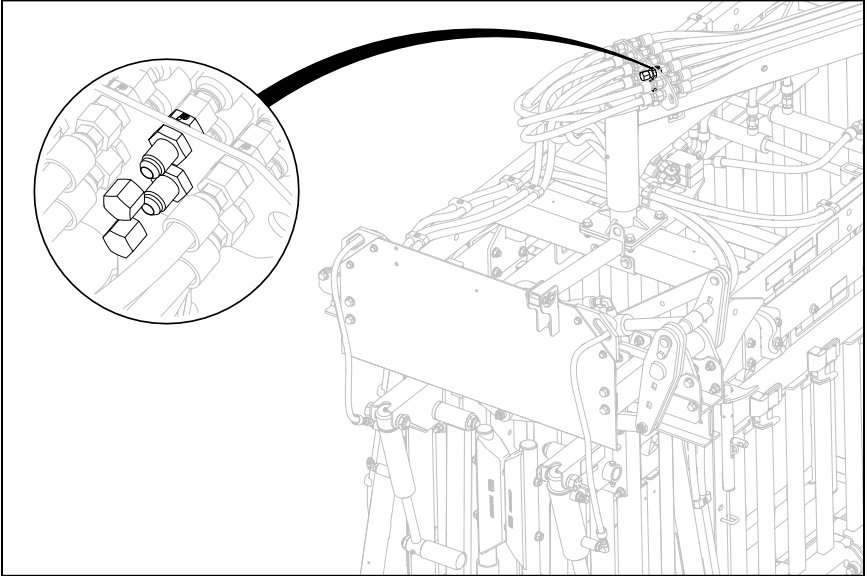

20. Connect hose (9000912) to the bottom auxiliary function and hose (9000913) to the top function.

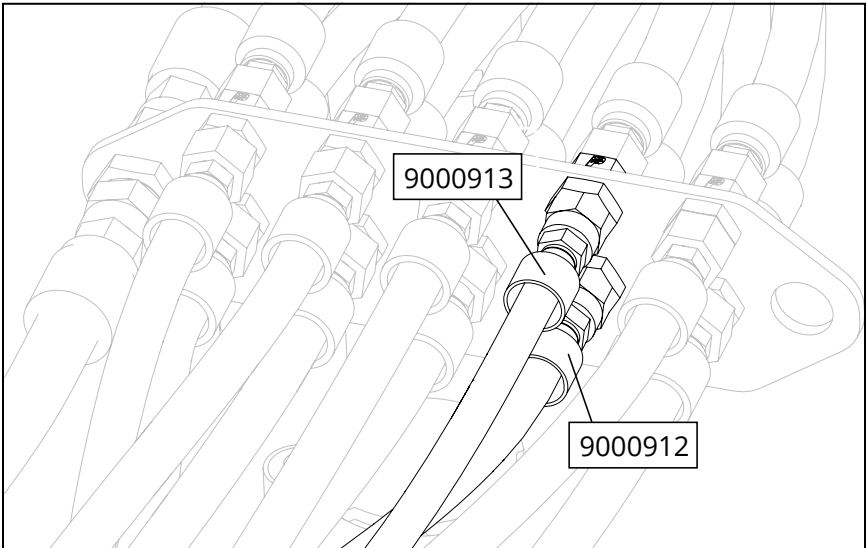

21. Route hoses along chute with hose clips (2017006) as shown. Fasten to frame with thread cutting bolt (7003213). Tighten enough so hoses do not come out of clips but not leave loose enough for hoses to move back and forth freely.

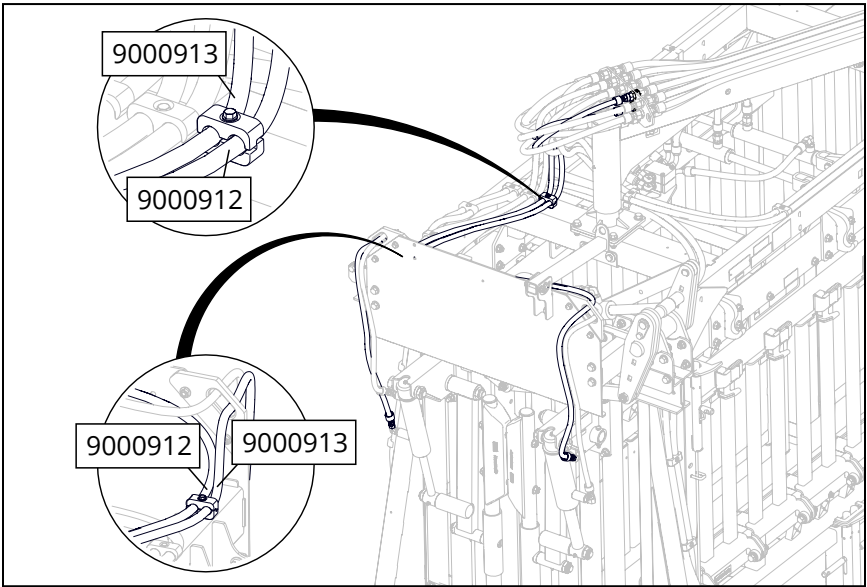

22. Route hose (9000912) along the back of the shield to LHS of chute and bore side of the LH master cylinder.

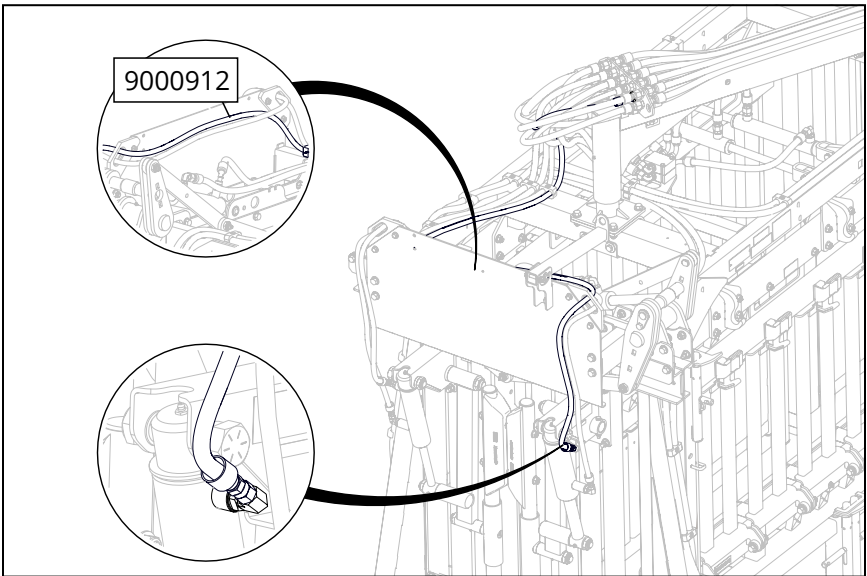

23. Route hose (9000913) to the rod side of the RHS slave cylinder.

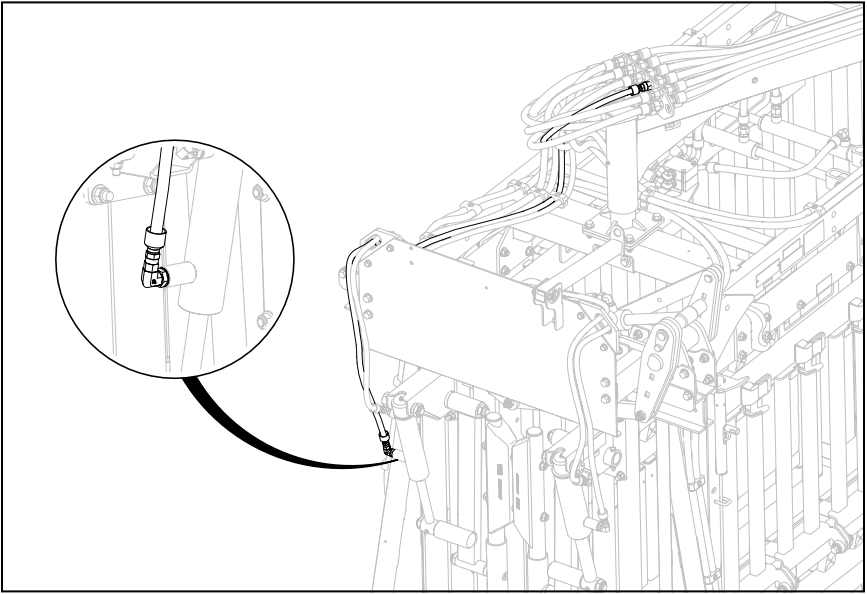

24. Secure routed hoses together using hose clips (2017006), 1/4" x 1.75" long bolt (7002319) and nut (7002102) where shown. Leave loose enough to slide hoses through clips.

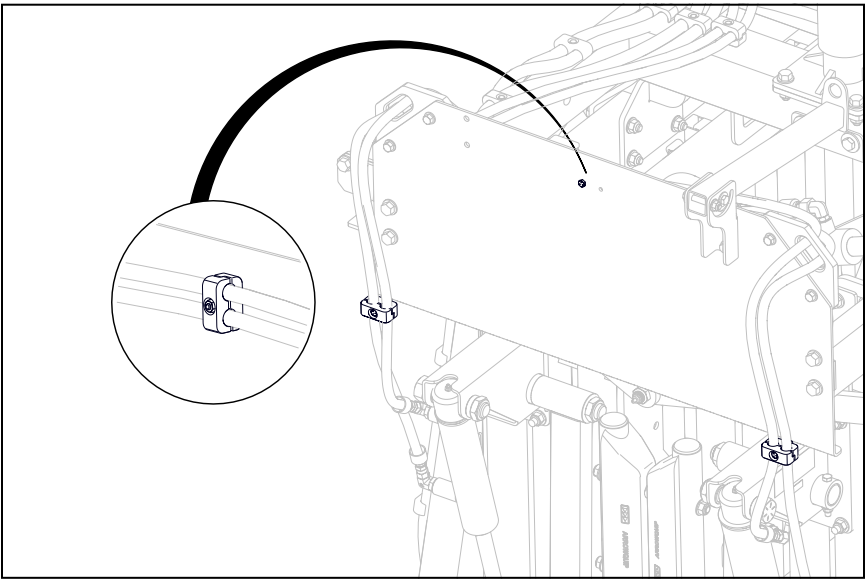

25. Adjust the hoses in front of the shield to ensure there is enough slack so they do not pull too tight when opening or closing the head gate doors. Once you have confirmed the hoses move freely through the full range of motion, tighten down all 5 sets of hose clips to secure them.

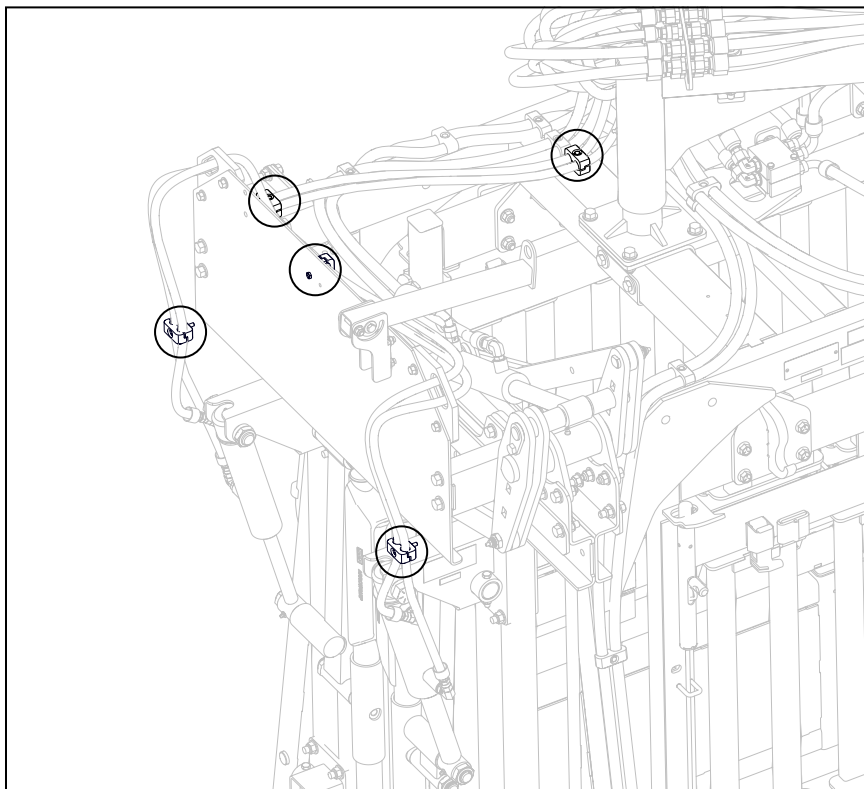

26. Neck extenders are now ready to fill with oil. This can be done by retracting the neck extenders towards the head gate, pulling the control on the spool valve control towards you. Hold the control for 30-60 seconds as oil will need time to work through the rephasing ports.
27. Extend the neck extenders all the way out. If they do not move in sync there is still air in the system. Repeat step 26 until neck extenders move in unison. Neck extenders are ready for use.

NOTE: Clean spilled oil off rubber floor as soon as possible. Prolonged exposure to hydraulic oil can cause rubber mats to swell.

REGULAR MAINTENANCE

1. Grease Cylinders and linkage pivots through provided zerks every 1000 Head or Annually (12 places).

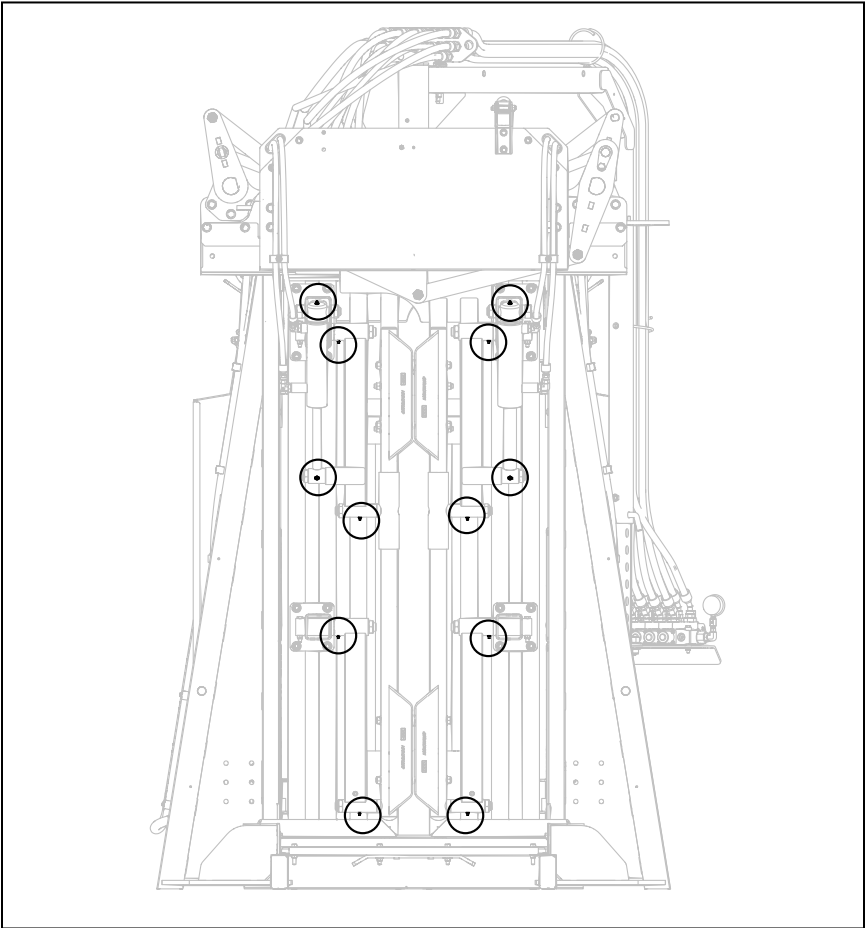





THE GENERAL POWER BEYOND KIT

NOTE: These instructions are only to install the 5 extra functions to the main hydraulic circuit of the SD11. It is the responsibility of the user for making hoses and plumbing the auxiliary functions to the power beyond valve bank.

REQUIREMENTS:

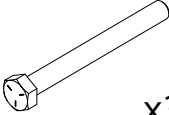
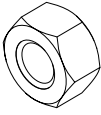
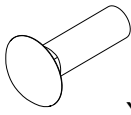
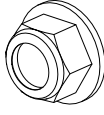
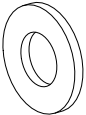
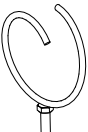
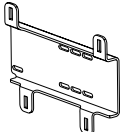
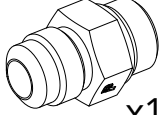
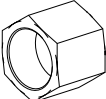
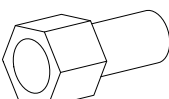
- Oil cleanup supplies
- 12mm Allen key
- Wrenches/Sockets
 - 2 x 1/2"
 - 2 x 9/16"
 - 2 x 3/4"
 - 2 x 11/16"
 - 13/16"
 - 2 x 7/8"
 - 2 x 1-1/16"
 - 1-1/4"

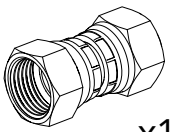
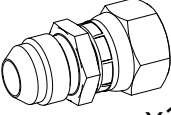
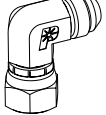
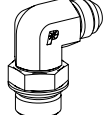
USER ASSEMBLY PARTS LIST

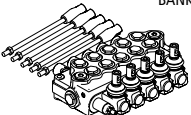
<p>7002981 BOLT-HH-0.3125-18-3-Z5</p>  <p>x3</p>	<p>7002320 NUT-NYL-0.3125-18-Z5</p>  <p>x3</p>	<p>7002076 BOLT-CAR-0.375-16-1.25-Z5-FIT</p>  <p>x3</p>	<p>7003178 NUT-FNYL-0.375-16-Z5</p>  <p>x3</p>
<p>7002357 WASHER-0.375-0.875-0.064-ZPS</p>  <p>x3</p>	<p>2004255 HOSE RING WELDING</p>  <p>x3</p>	<p>2037579 ARMY POWER BEYOND PLATE - GRN</p>  <p>x1</p>	<p>9000211 08-08 M ORB-JIC CONNECTOR</p>  <p>x11</p>
<p>9000584 -08 JIC CAP</p>  <p>x10</p>	<p>9000609 SAE10 POWER BEYOND SLEEVE</p>  <p>x1</p>	<p>9000209 08-08 M M ORB-JIC 90° ELBOW</p>  <p>x1</p>	<p>9000837 08-08 F-F JIC SWIVEL</p>  <p>x1</p>
<p>9000733 08-08 M F JIC-JIC CONNECTOR</p>  <p>x1</p>	<p>9000724 08-08 M F JIC 90° ELBOW</p>  <p>x1</p>	<p>9000767 10-08 M M ORB-JIC 90° ELBOW</p>  <p>x1</p>	<p>9000757 12-08 M M ORB-JIC 90° ELBOW</p>  <p>x1</p>
<p>9000542 WALVOIL SD5 5 VALVE BANK</p>  <p>x1</p>	<p>9000990 ARMY POWER BEYOND HOSE</p> <p>x1</p>		

INSTALLATION:



ENSURE THE CHUTE HAS BEEN PHYSICALLY DISCONNECTED FROM THE HYDRAULIC POWER SOURCE BEFORE BEGINNING INSTALLATION. THIS CAN PREVENT ACCIDENTAL START UP AND LIMIT THE AMOUNT OF OIL LOST FROM THE CHUTE DURING INSTALLATION.

1. Install hose guide rings (2004255) into pre-installed rivnuts in the swing arm.

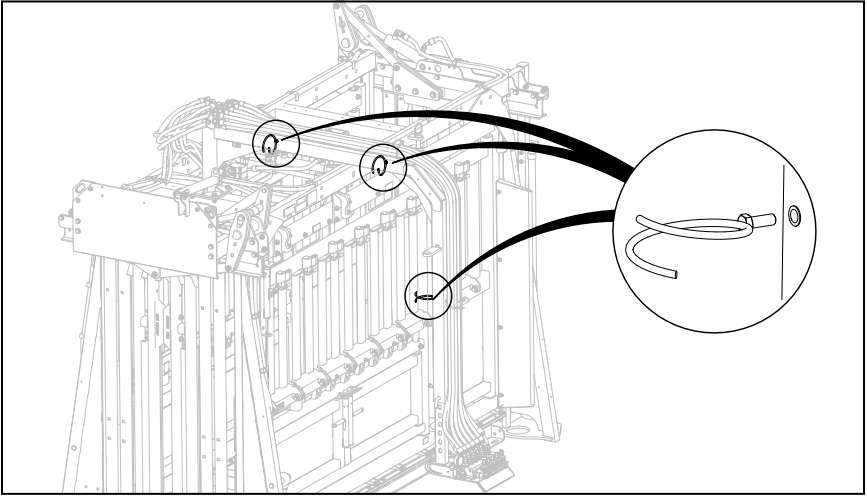

2. Remove all factory installed plastic plugs from power beyond spool valve (9000542). Valve will come with handles in the box. These can be set aside to be installed later.

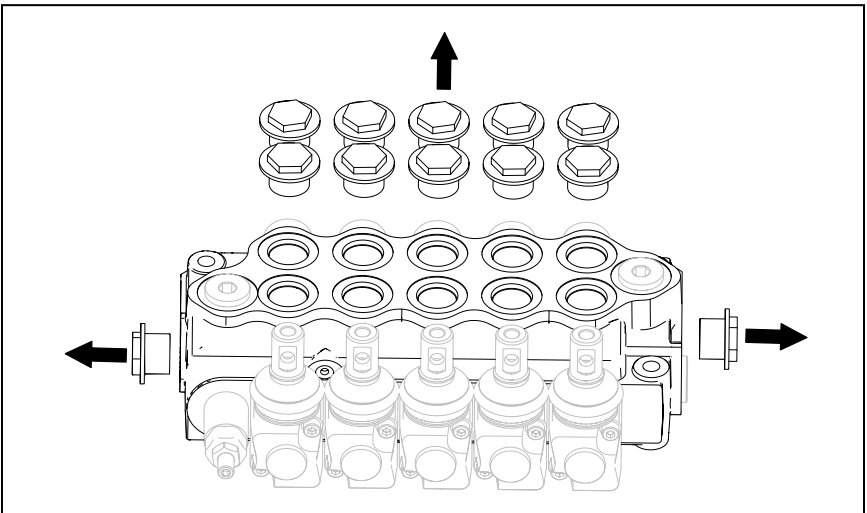

3. Install the -08 ORB-JIC connectors (9000211) and -08 JIC cap (9000584) to the 10 function ports on valve.

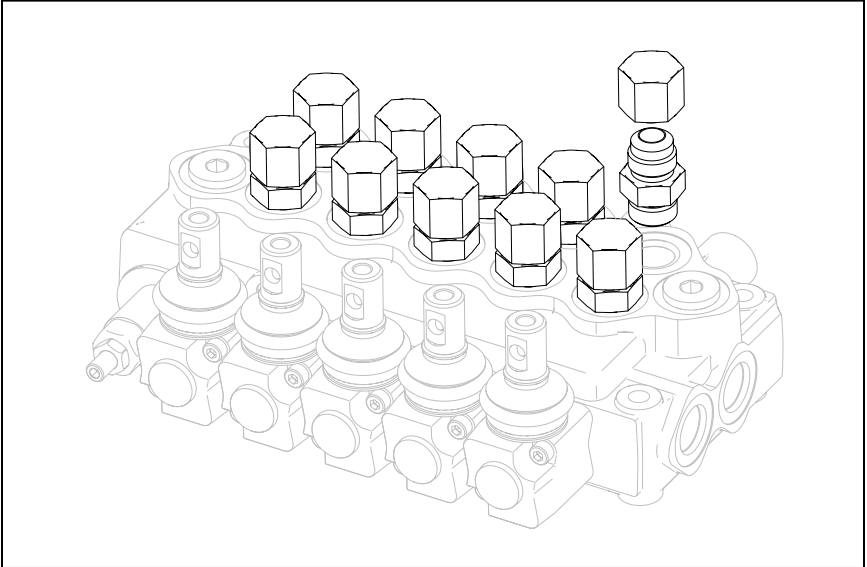

4. Install -08 ORB-JIC 90° elbow (9000209) and -08 ORB-JIC connector (9000211) on the side ports of the valve in the orientations shown. Do not tighten jam nut on elbow fitting as angle may need to be adjusted.

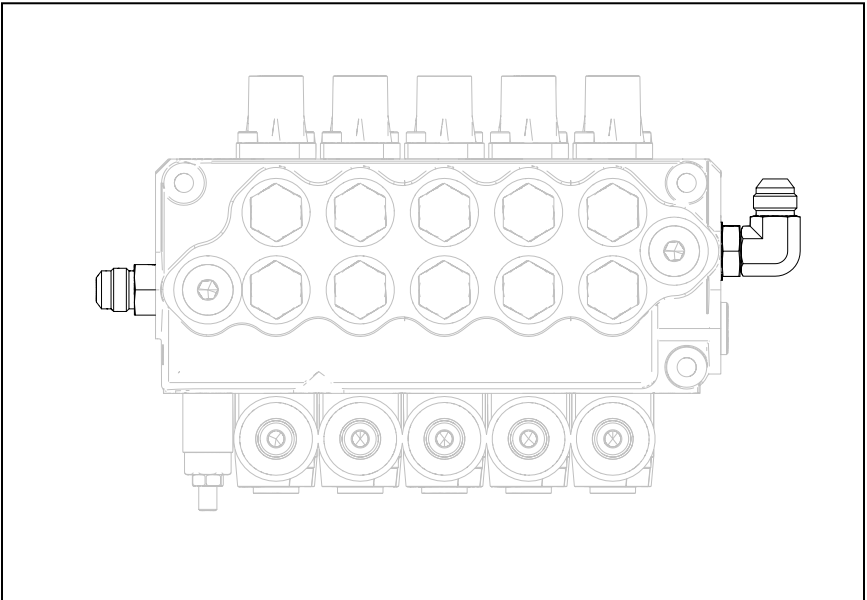

5. Mount sub-assembled valve bank to the power beyond plate (2037579) with 5/16" x 3" long hex head bolt (7002981), washer (7002357), and nut (7002320). Leave hardware loose enough to shift the valve bank in the slots of the plate.

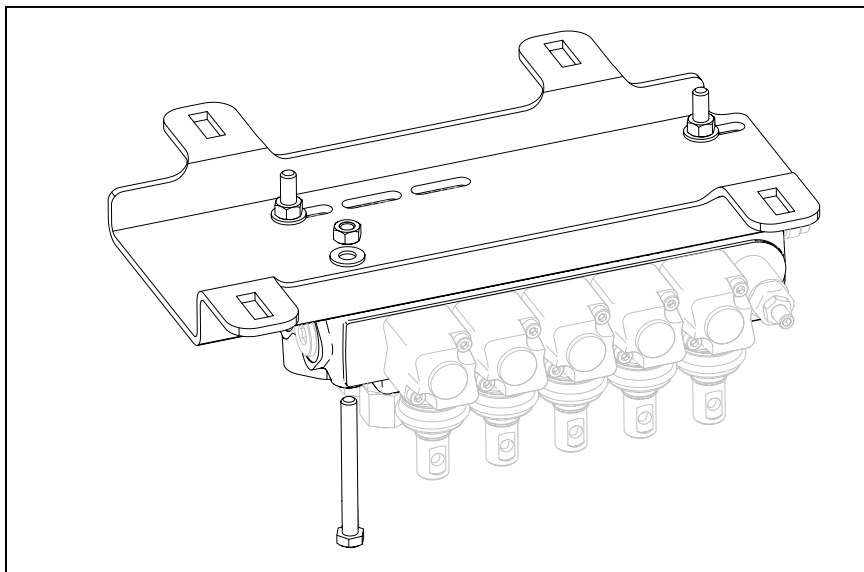

6. Remove all three bolts holding main chute valve bank to valve plate on the swing arm.

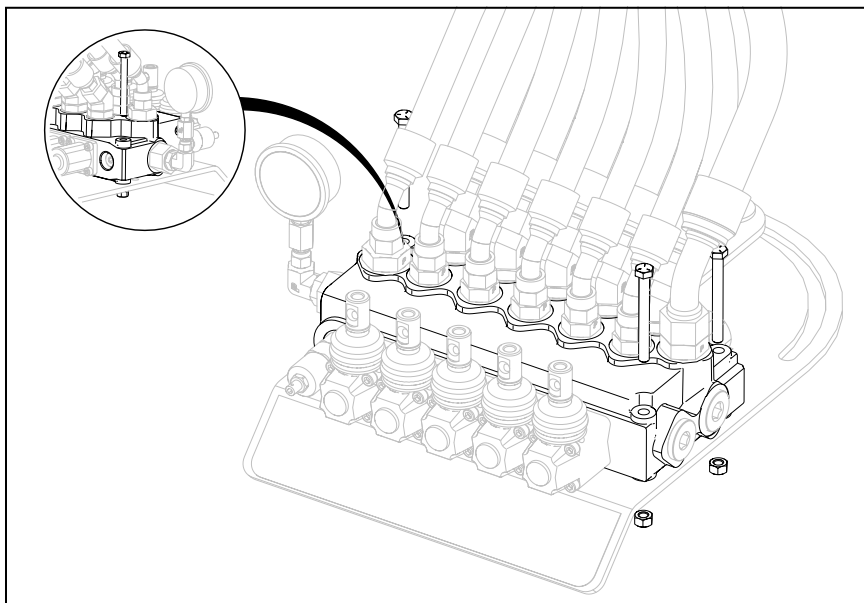

7. Shift main valve bank to the right to uncover the carriage hole in corner of mount plate. Install 3/8" x 1.25" long carriage head bolt (7002076) as shown.

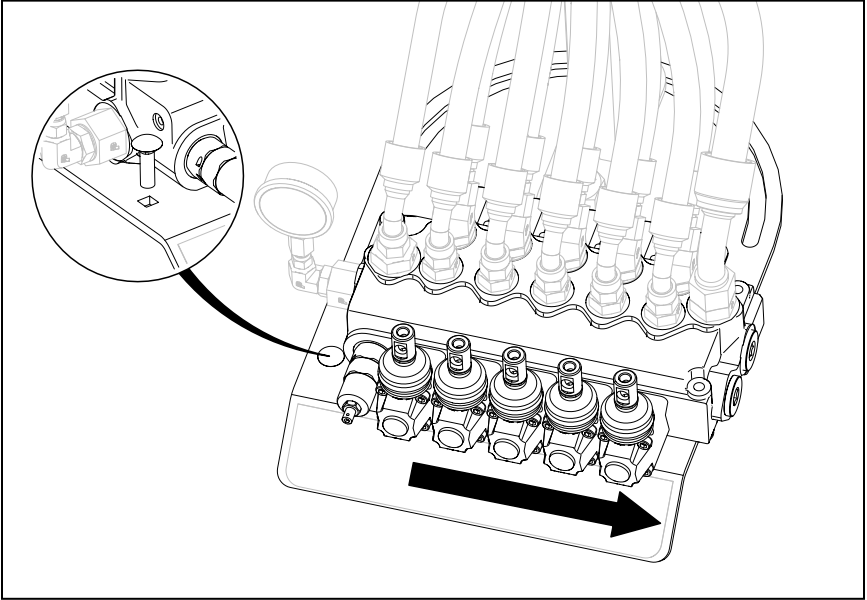

8. Main valve bank can be shifted back to original position, and rear bolts can be installed and tightened.

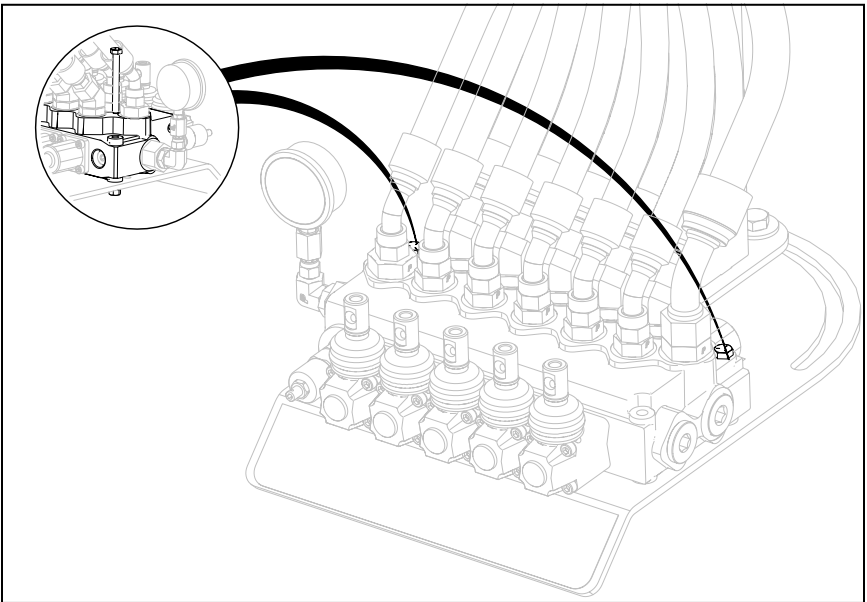

9. Use 3/8" x 1.25" long carriage head bolt (7002076), nut (7003178), and leftover hardware removed in Step 6 to mount sub-assembled power beyond plate. Leave loose enough so plate can still be shifted in the slots.

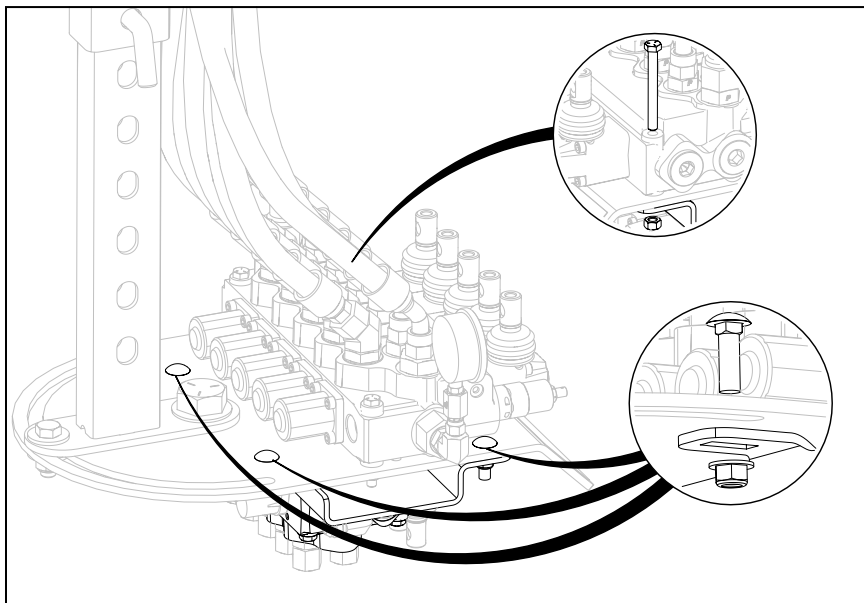

THE NEXT STEP WILL OPEN THE HYDRAULICS OF THE MAIN VALVE BANK. BE READY WITH SUPPLIES TO CONTAIN OIL THAT WILL LEAK FROM THE SYSTEM.

10. Remove plugs on right hand side of main valve bank.

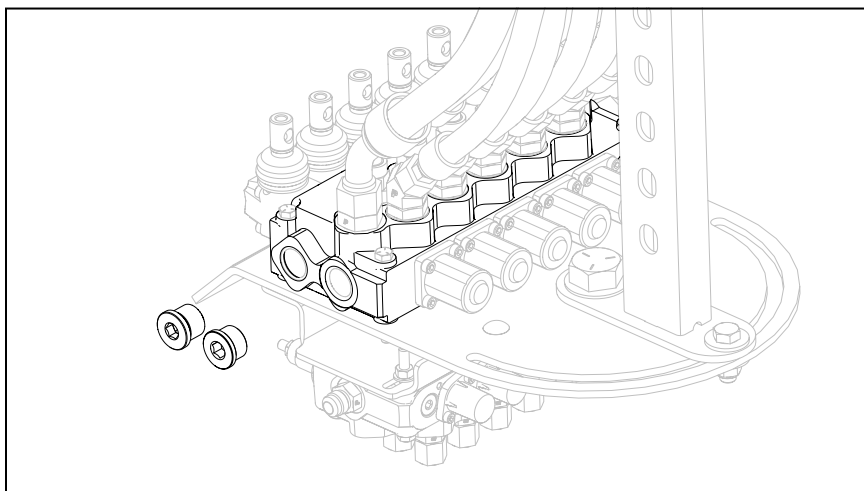

11. Install 12-08 ORB-JIC 90° Elbow (9000757) in orientation shown.

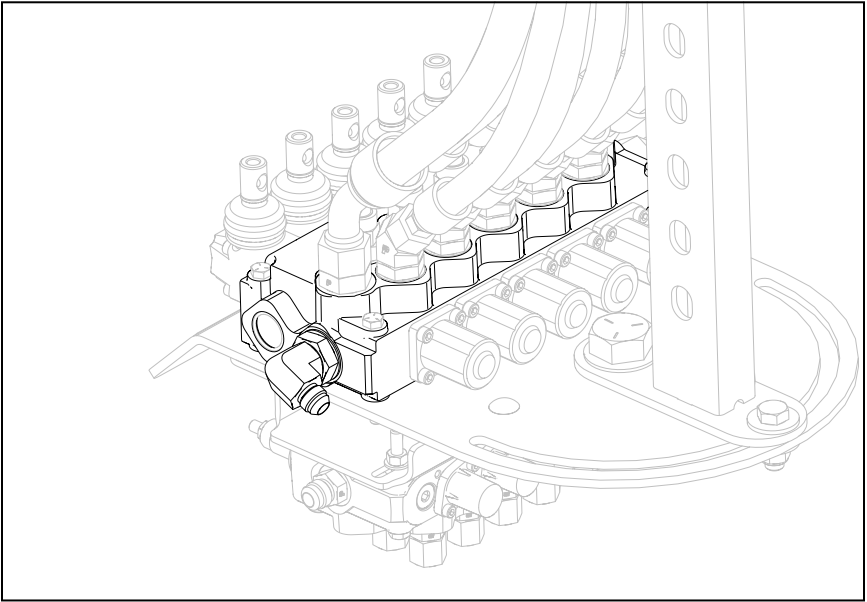

12. Install power beyond sleeve (9000609) and elbow 10-08 ORB-JIC 90° Elbow (9000767) in side port as shown.

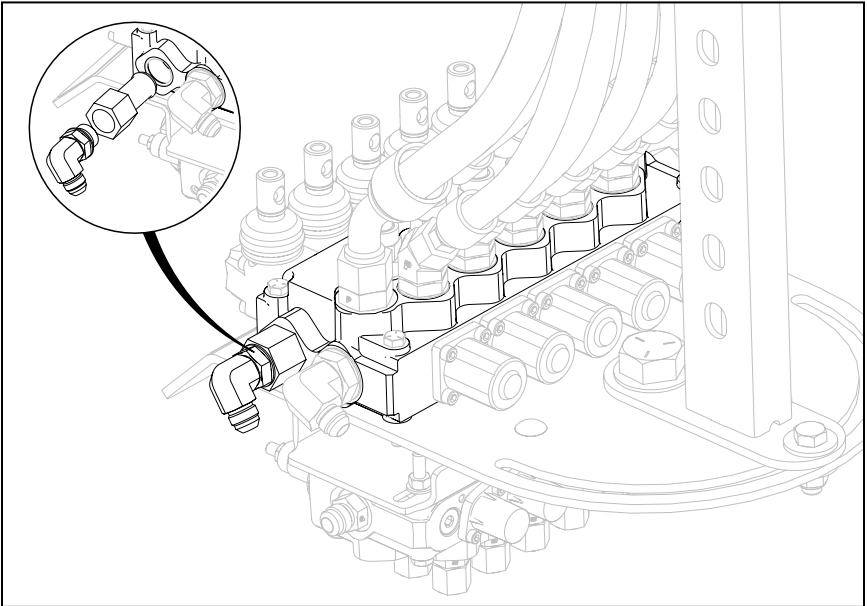

13. The two valve banks can now be joined using -08 Swivel Connectors (9000837) and (9000733) plus -08 M F JIC 90° Elbow (9000724).

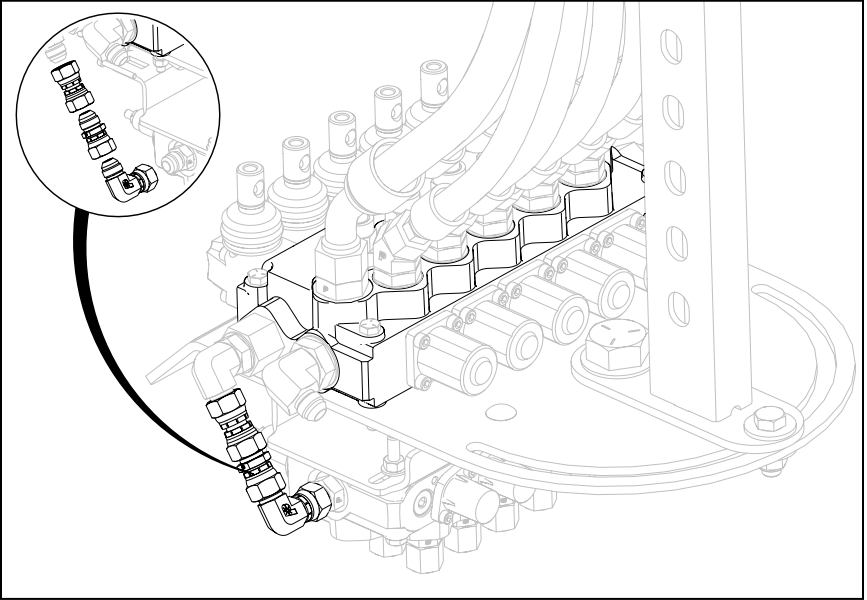

14. All three elbow fittings can be locked in their orientations.

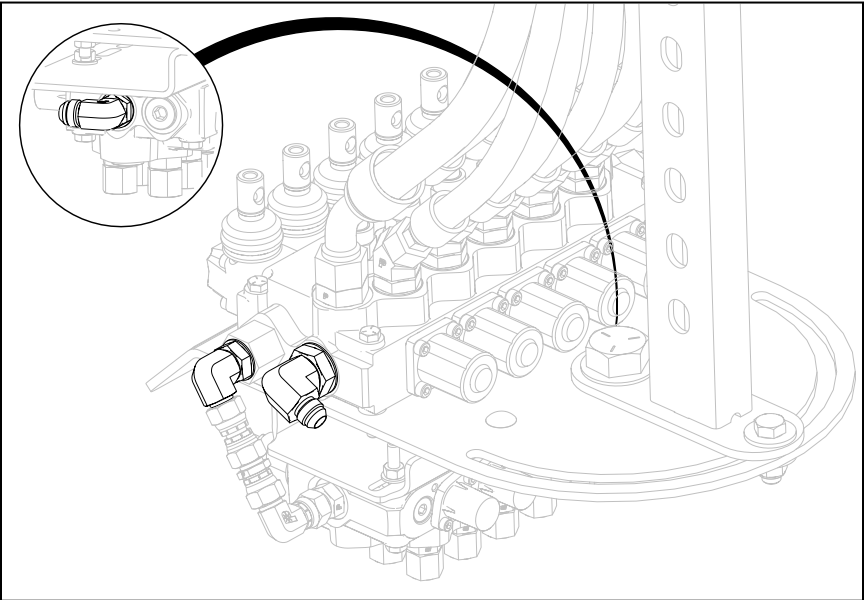

15. Tighten all hardware holding valve banks

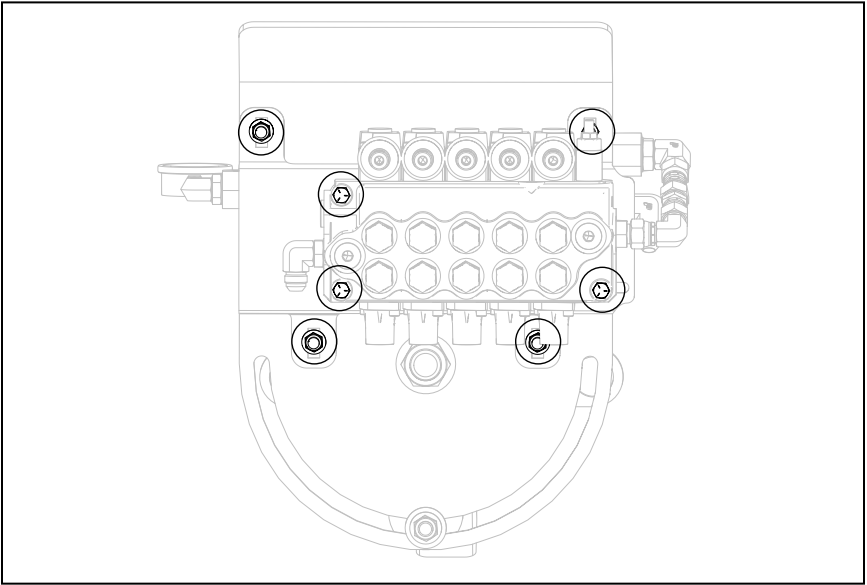

16. Install hose (9000990) to connect tank lines of valve banks.

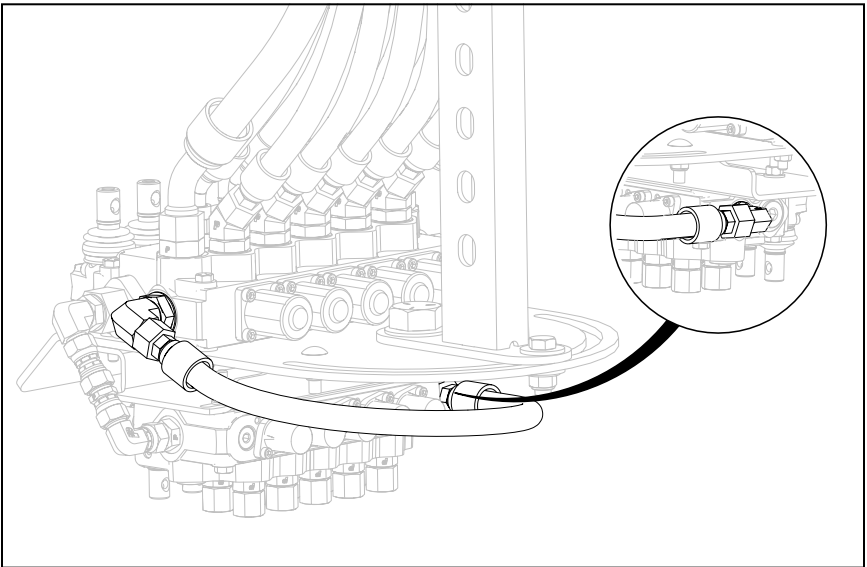

The 5 power beyond functions are now plumbed to the main hydraulic circuit and can be connected to your auxiliary functions.



THE MAJOR POWER BEYOND KIT

NOTE: These instructions are only to install the 5 extra functions to the main hydraulic circuit of the SD5. It is the responsibility of the user for making hoses and plumbing the auxiliary functions to the power beyond valve bank.

REQUIREMENTS:

- Oil cleanup supplies
- Allen Keys
 - 6mm
 - 8mm
- Wrenches/Sockets
 - 2 x 1/2"
 - 2 x 9/16"
 - 2 x 3/4"
 - 2 x 11/16"
 - 13/16"
 - 2 x 7/8"
 - 2 x 1-1/16"

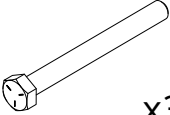
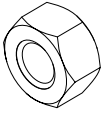
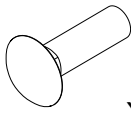
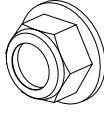
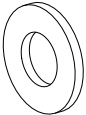
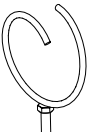
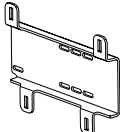
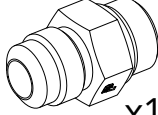
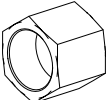
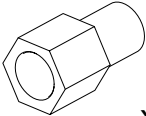
USER ASSEMBLY PARTS LIST

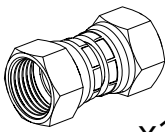
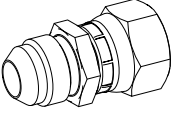
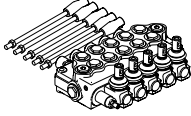
<p>7002981 BOLT-HH-0.3125-18-3-Z5</p>  <p>x3</p>	<p>7002320 NUT-NYL-0.3125-18-Z5</p>  <p>x3</p>	<p>7002076 BOLT-CAR-0.375-16-1.25-Z5-FT</p>  <p>x3</p>	<p>7003178 NUT-FNYL-0.375-16-Z5</p>  <p>x3</p>
<p>7002357 WASHER-0.375-0.875-0.064-ZPS</p>  <p>x3</p>	<p>2004255 HOSE RING WELDING</p>  <p>x3</p>	<p>2037579 ARMY POWER BEYOND PLATE - GRN</p>  <p>x1</p>	<p>9000211 08-08 M ORB-JIC CONNECTOR</p>  <p>x10</p>
<p>9000584 -08 JIC CAP</p>  <p>x10</p>	<p>9000608 SAE8 POWER BEYOND SLEEVE</p>  <p>x1</p>	<p>9000209 08-08 M M ORB-JIC 90° ELBOW</p>  <p>x4</p>	<p>9000837 08-08 F-F JIC SWIVEL</p>  <p>x1</p>
<p>9000733 08-08 M F JIC-JIC CONNECTOR</p>  <p>x1</p>	<p>9000542 WALVOIL SD5 5 VALVE BANK</p>  <p>x1</p>	<p>9000990 ARMY POWER BEYOND HOSE</p> <p>x1</p>	

INSTALLATION:



ENSURE THE CHUTE HAS BEEN PHYSICALLY DISCONNECTED FROM THE HYDRAULIC POWER SOURCE BEFORE BEGINNING INSTALLATION. THIS CAN PREVENT ACCIDENTAL START UP AND LIMIT THE AMOUNT OF OIL LOST FROM THE CHUTE DURING INSTALLATION.

1. Install hose guide rings (2004255) into pre-installed rivnuts in the swing arm.

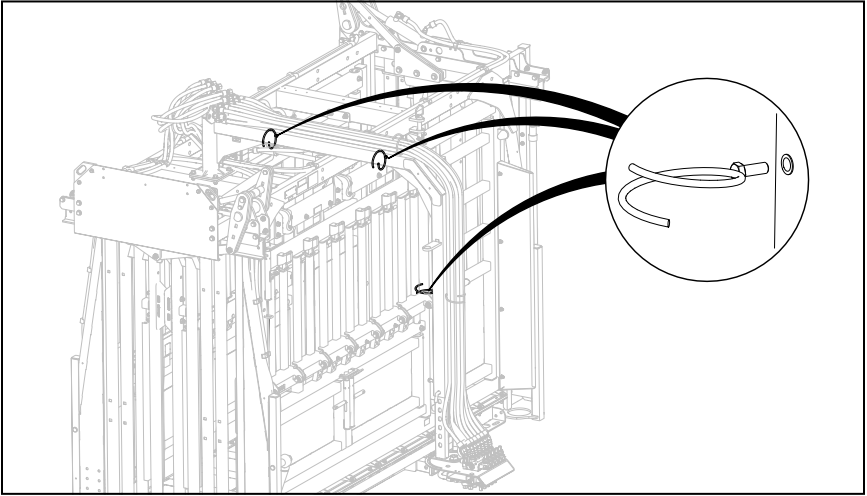

2. Remove all factory installed plastic plugs from power beyond spool valve (9000542). Valve will come with handles in the box. These can be set aside to be installed later.

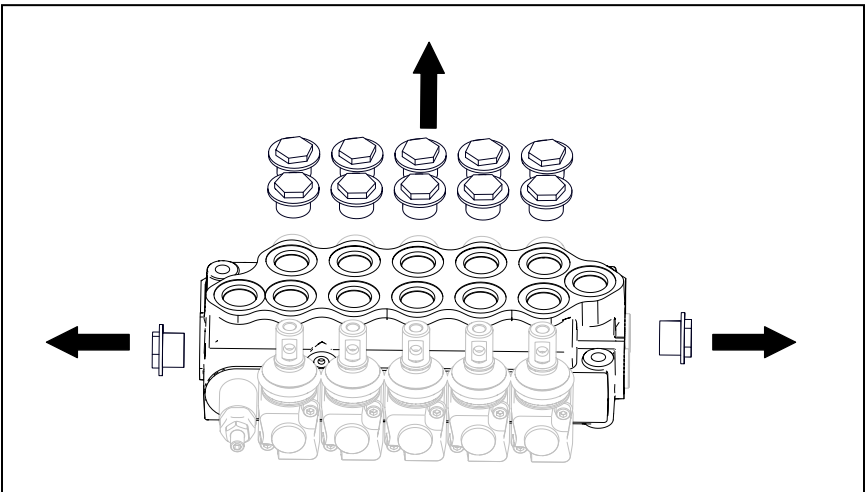

3. Install the -08 ORB-JIC connectors (9000211) and -08 JIC cap (9000584) to the 10 function ports on valve.

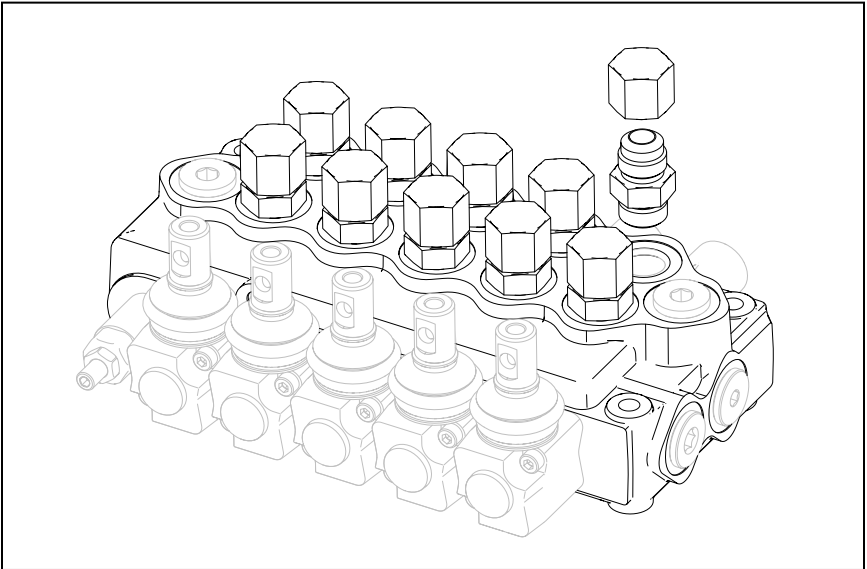

4. Install -08 ORB-JIC 90° elbows (9000209) on the side ports of the valve in the orientations shown. Do not tighten jam nut as angle may need to be adjusted.

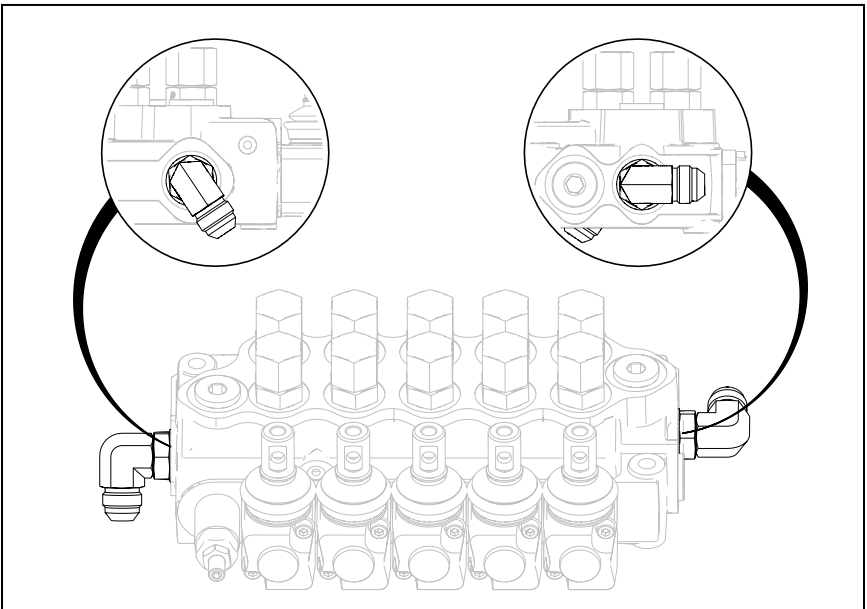

5. Mount sub-assembled valve bank to the power beyond plate (2037579) with 5/16" x 3" long hex head bolt (7002981), washer (7002357), and nut (7002320). Leave hardware loose enough to shift the valve bank in the slots of the plate.

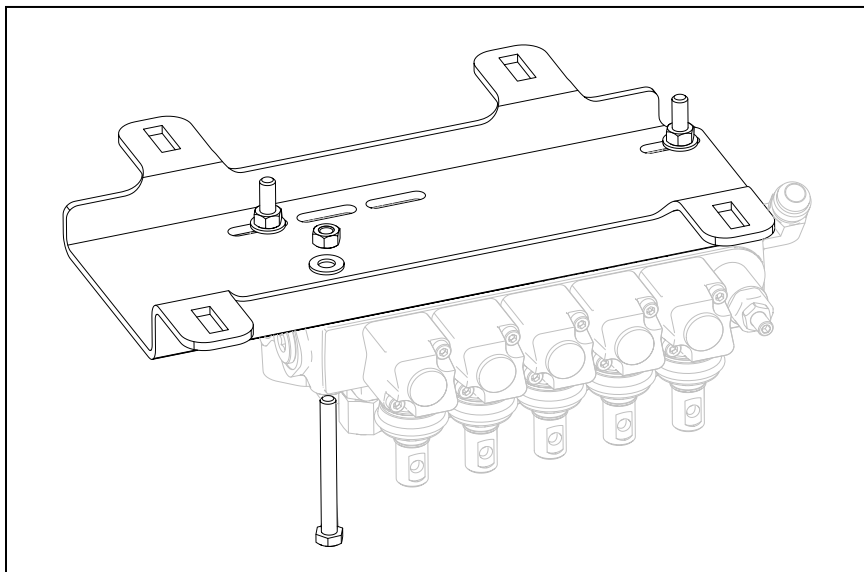

6. Remove bolt holding bottom right corner of main chute valve bank and set aside.

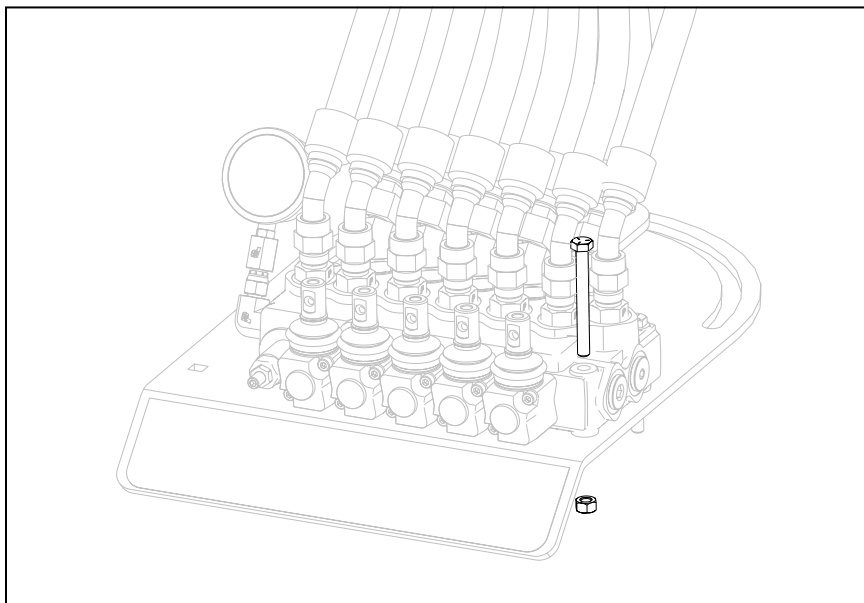

7. Mount sub-assembled power beyond plate using 3/8" x 1.25" long carriage head bolt (7002076), nut (7003178), and hardware removed in previous step. Leave loose enough so plate can still be shifted in the slots.

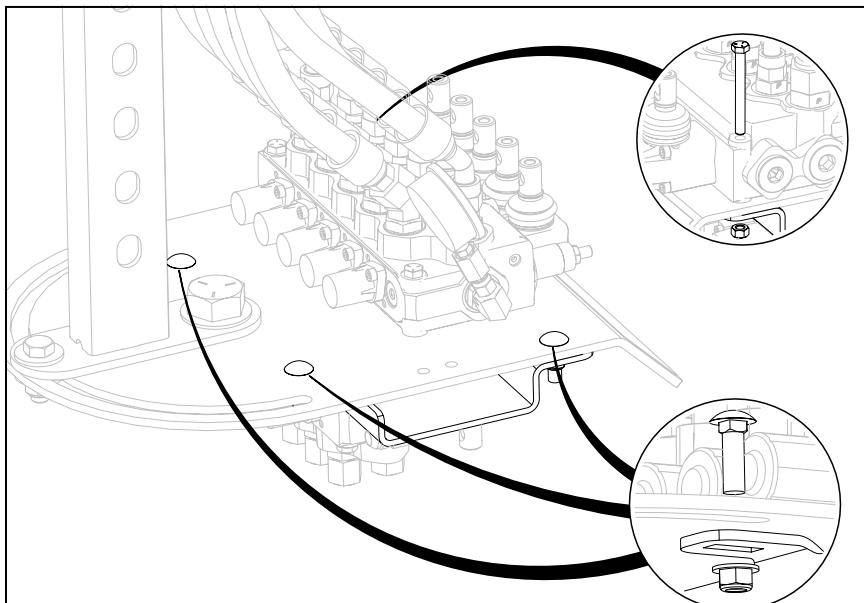

THE NEXT STEP WILL OPEN THE HYDRAULICS OF THE MAIN VALVE BANK. BE READY WITH SUPPLIES TO CONTAIN OIL THAT WILL LEAK FROM THE SYSTEM.

8. Remove plugs on right hand side of main valve bank.

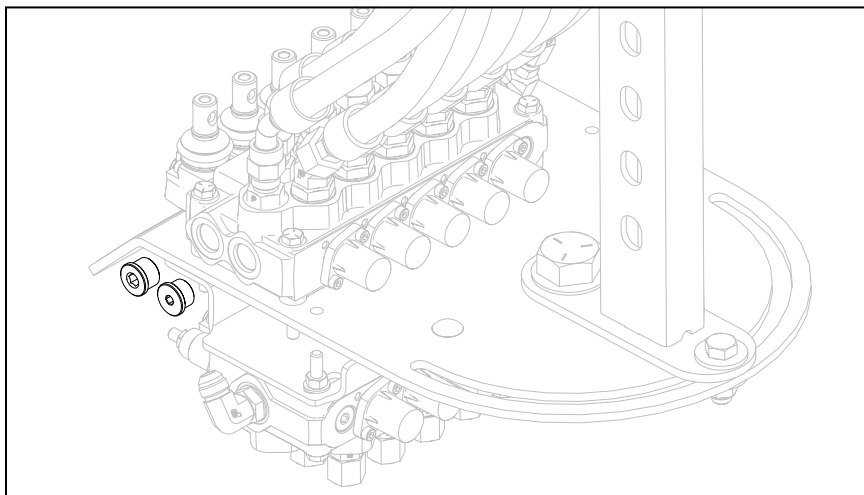

9. Install -08 ORB-JIC 90° Elbow (9000209) in orientation shown.

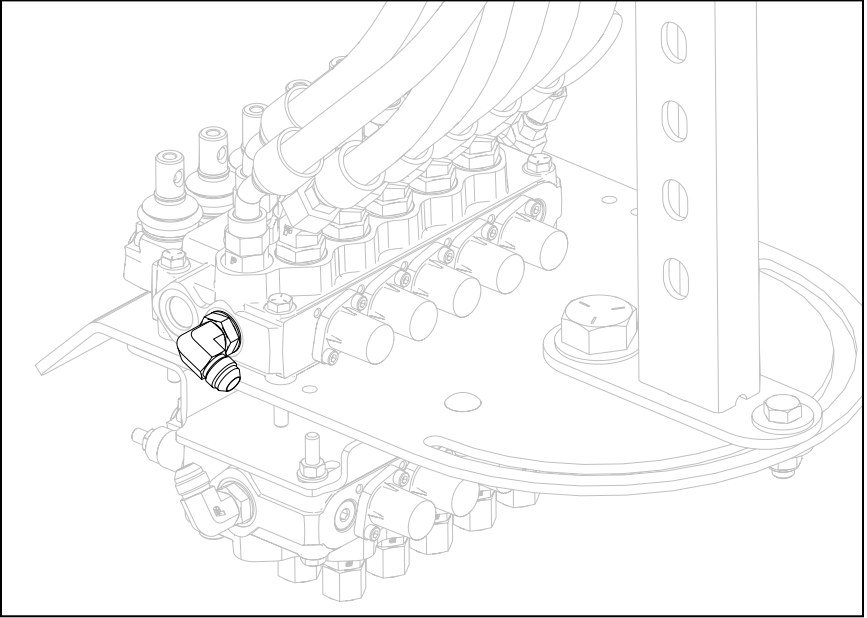

10. Install power beyond sleeve (9000608) and elbow (9000209) in the side port as shown.

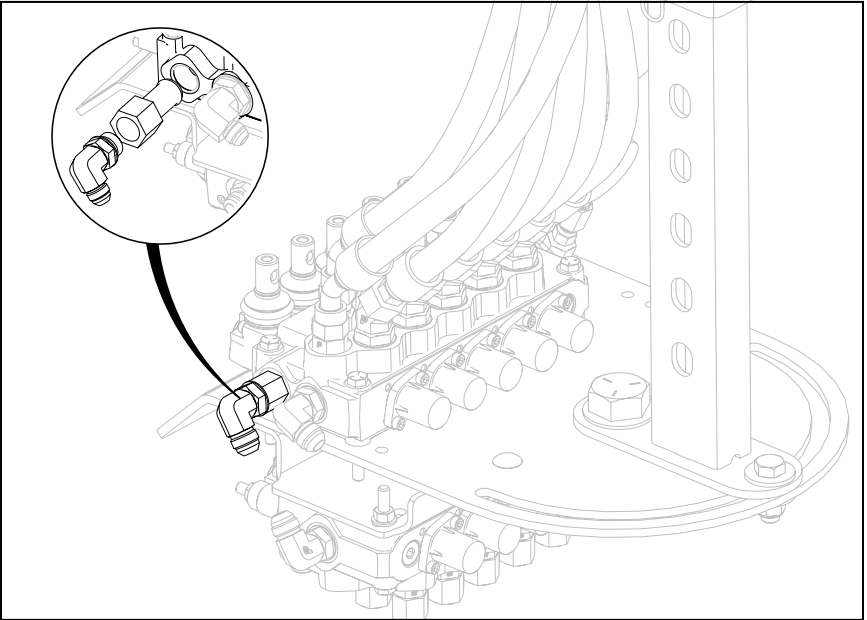

11. The two valve banks can now be joined using swivel connectors (9000837) and (9000733).

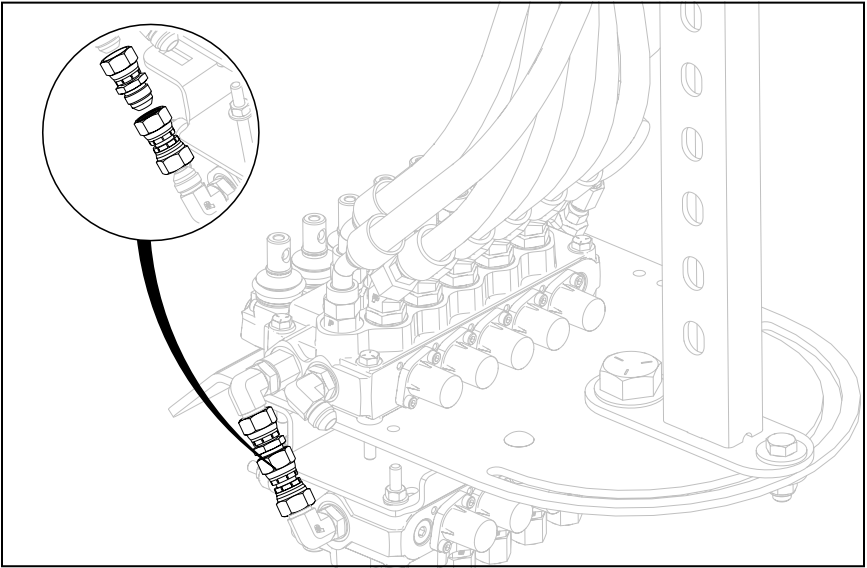

12. All four elbow fittings can be locked in their orientations.

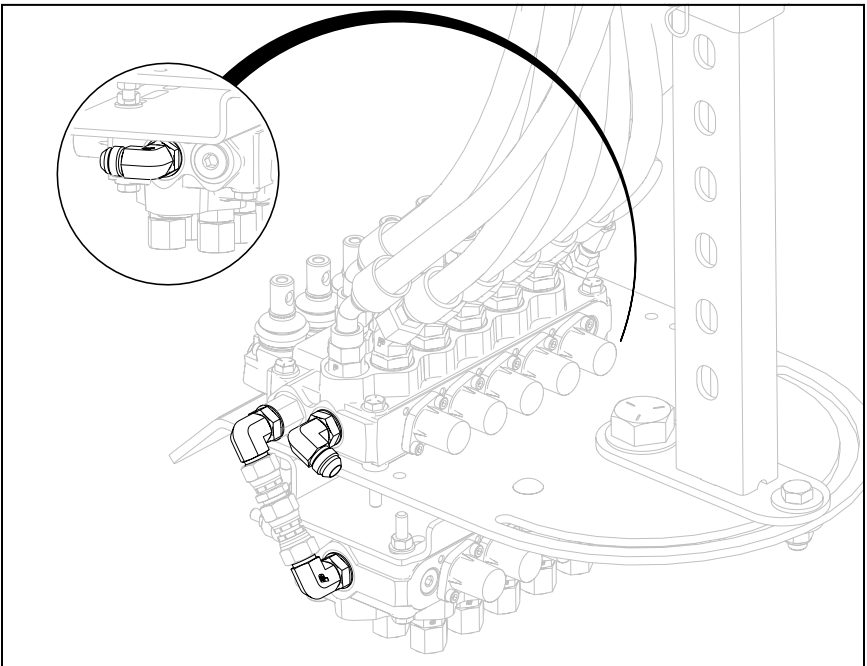

13. Tighten all hardware holding valve banks.

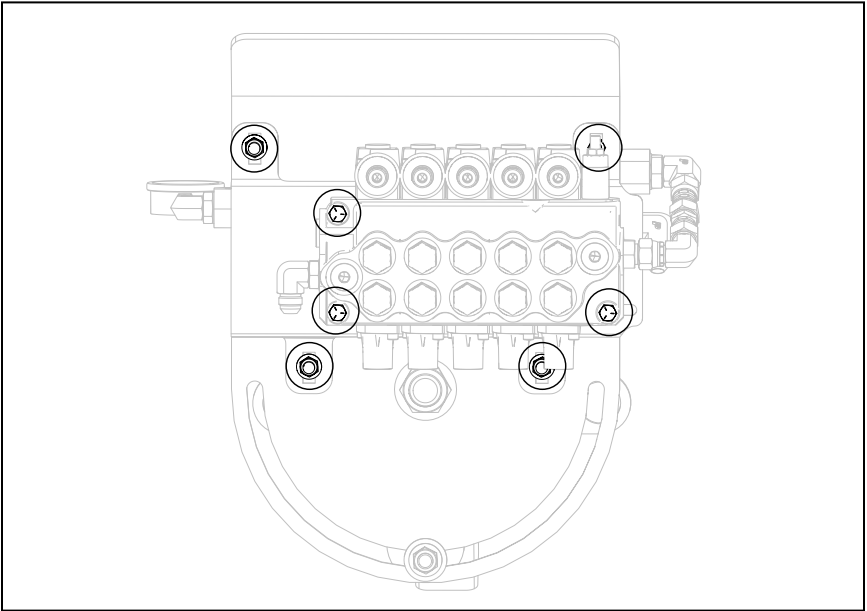

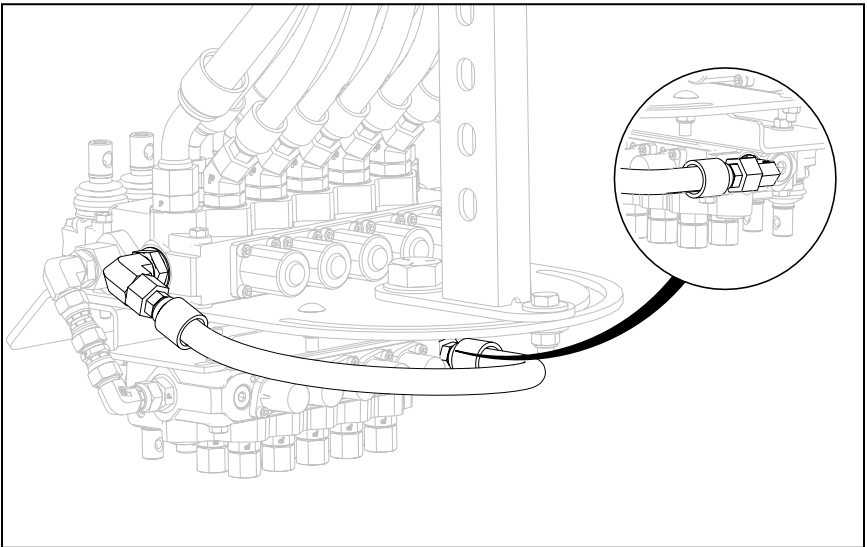

14. Install hose (9000990) to connect tank lines of valve banks.



The 5 power beyond functions are now plumbed to the main hydraulic circuit and can be connected to your auxiliary functions.

HEAD GATE SHOULDER CUSHIONS

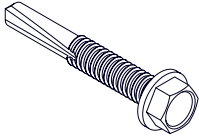
PARTS LIST:

7002969 #12X1-1/2" SELF TAPPING SCREW  x16	2013732 SHOULDER CUSHION STRIP  x4	2013729 SHOULDER CUSHION  x2
---	--	--

REQUIREMENTS:

- 2 People or 1 x Clamp
- 5/16" Socket

INSTALLATION:

NOTE: The below instructions show the HG-C Shoulder Cushion Kit being installed on a Powerlock 1075 Series Chute. The process for installation is the same for all other compatible chutes.

1. Insert Shoulder Cushion Strips (2013732) into Shoulder Cushions (2013729) until holes are aligned.

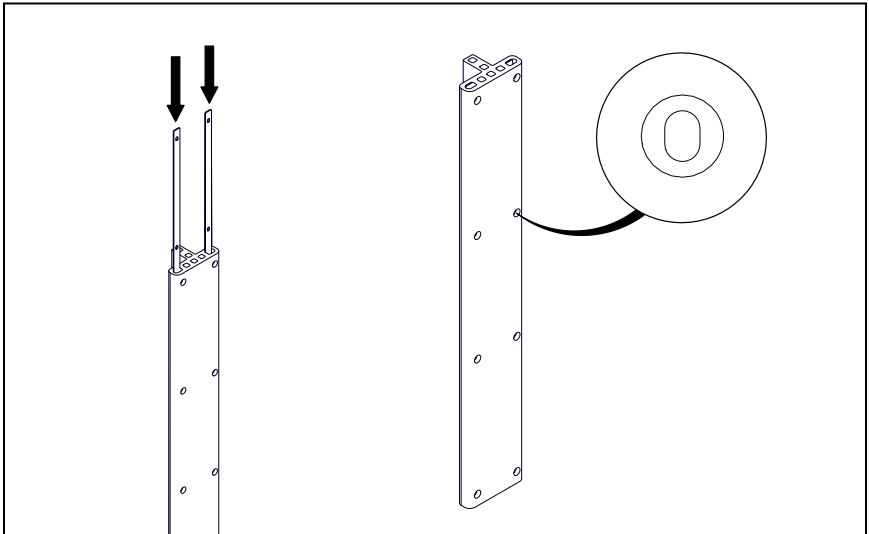

2. Using a clamp or a helper position the Shoulder Cushion as shown.
 - a. The bottom should be 11.25" from the floor.
 - b. The rib should be oriented to rest against outer tube so it is supported.

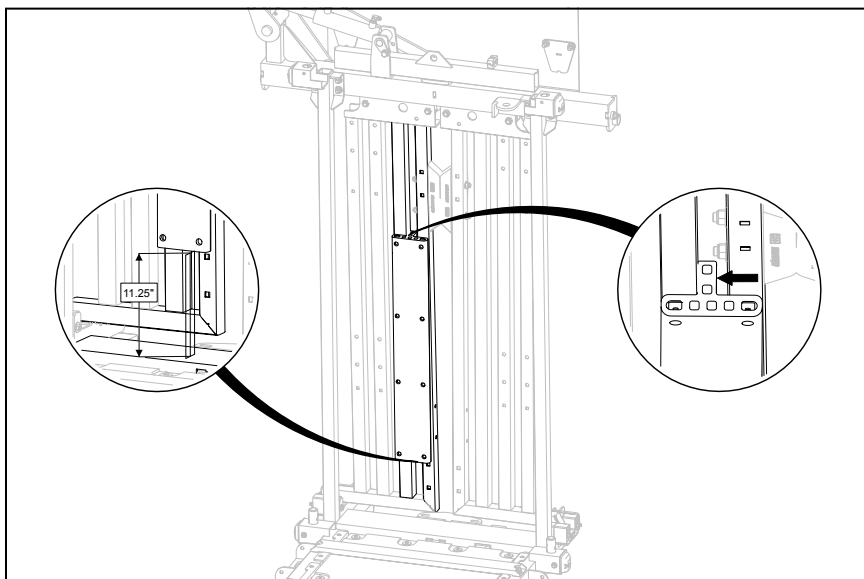

3. Use the self-tapping screws to secure the Shoulder Cushions to the Head Gate. Once secured, your Shoulder Cushions are ready for use.

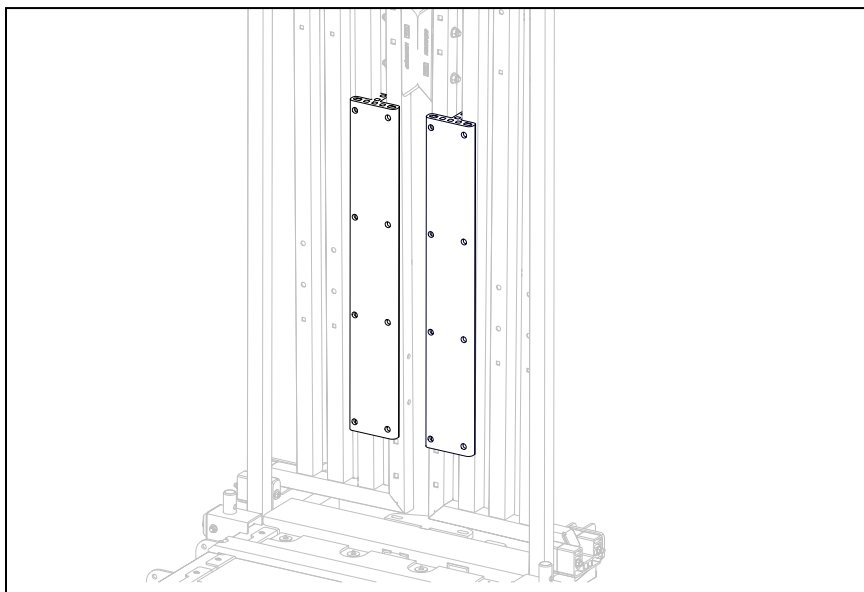

CALF RESTRAINER BAR

INSTALLATION

NOTE: The below instructions show the CFLR-88 Calf Restrainer Bar being installed on an 8800LV. The process for installation is the same for all other compatible chutes.

NOTE: Fork targets bolted to squeeze will need to be removed.

1. Open the emergency exit doors.

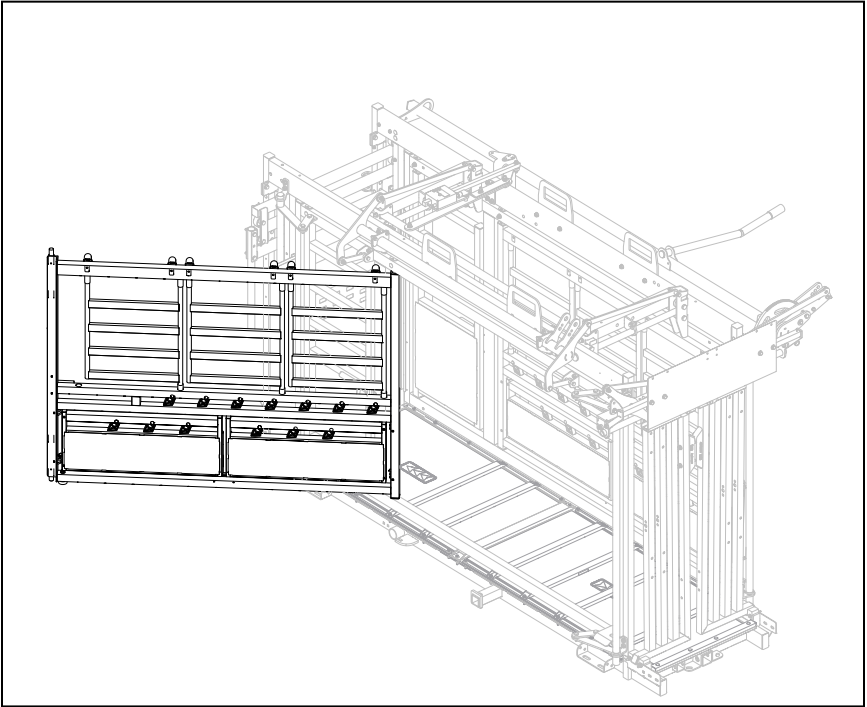

2. Insert Restrainer Bar so that top and bottom brackets are resting on squeeze frame tubes.

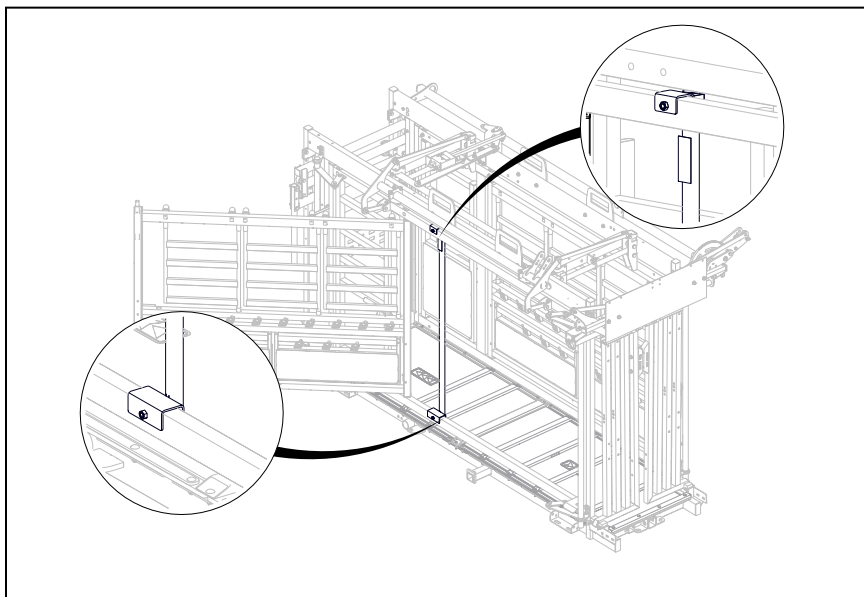

3. Adjust Calf Restrainer Bar to desired position and tighten knobs.

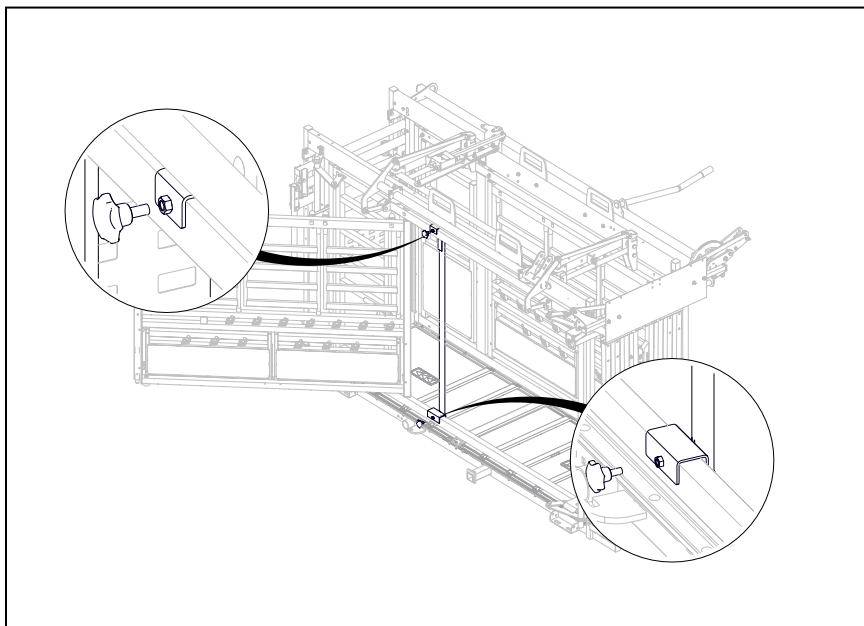

STERNUM BAR

REQUIREMENTS:

- 3/4" Wrench or Socket

INSTALLATION:

NOTE: The below instructions show the man-stbr sheeted sternum bar being installed on an 8800lv. The process for installation is the same for all other compatible chutes.

1. Remove stock bolts from front hold-down.

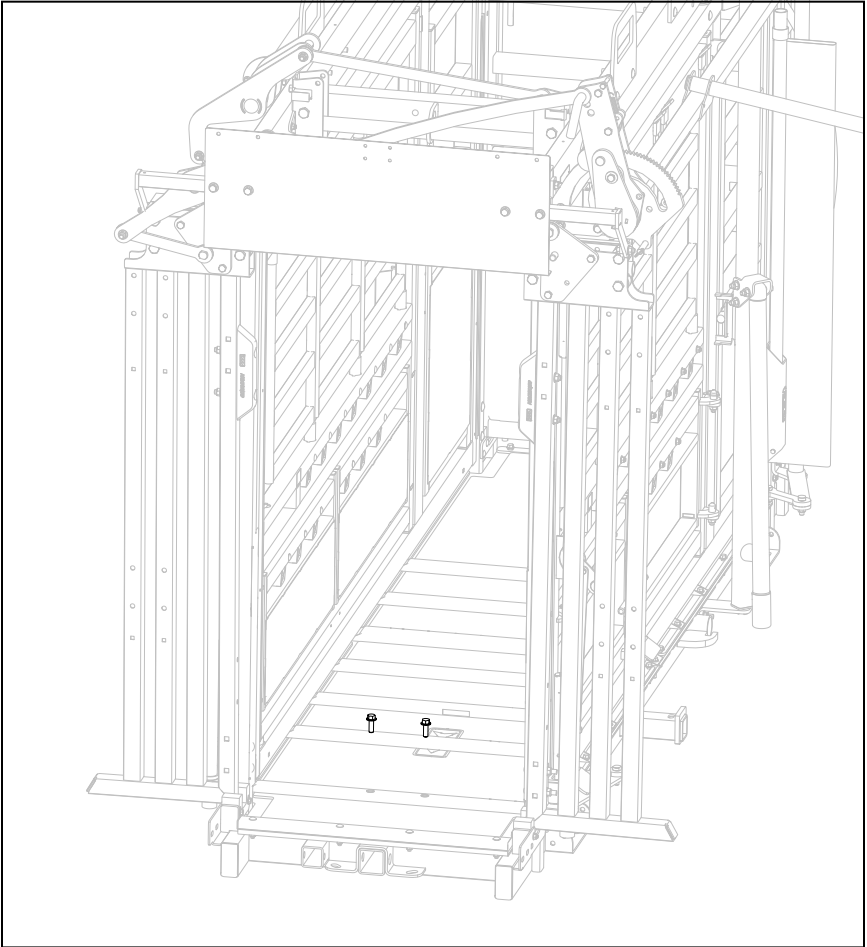

2. Remove stock bolts from front hold-down.

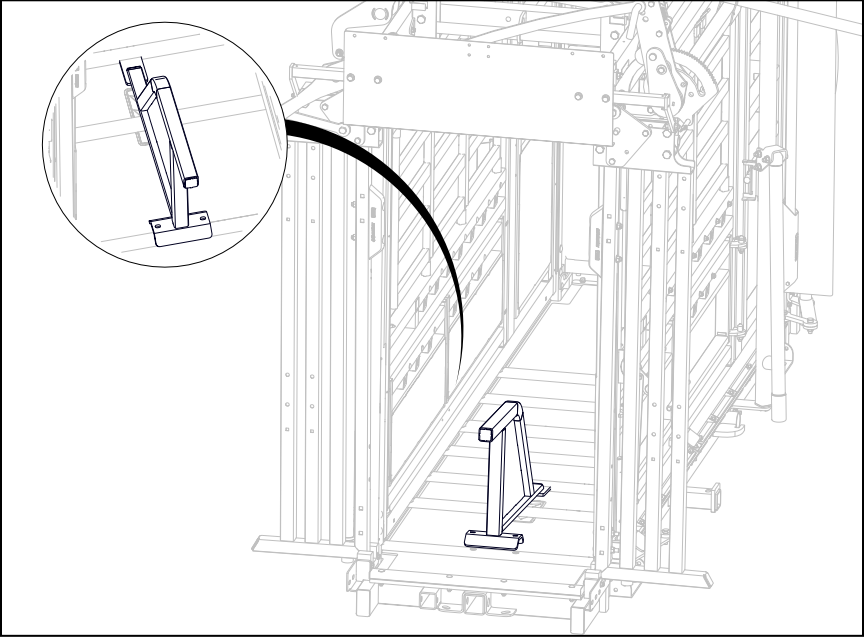

3. Fasten sternum bar front to front plate using provided 1/2" hardware.

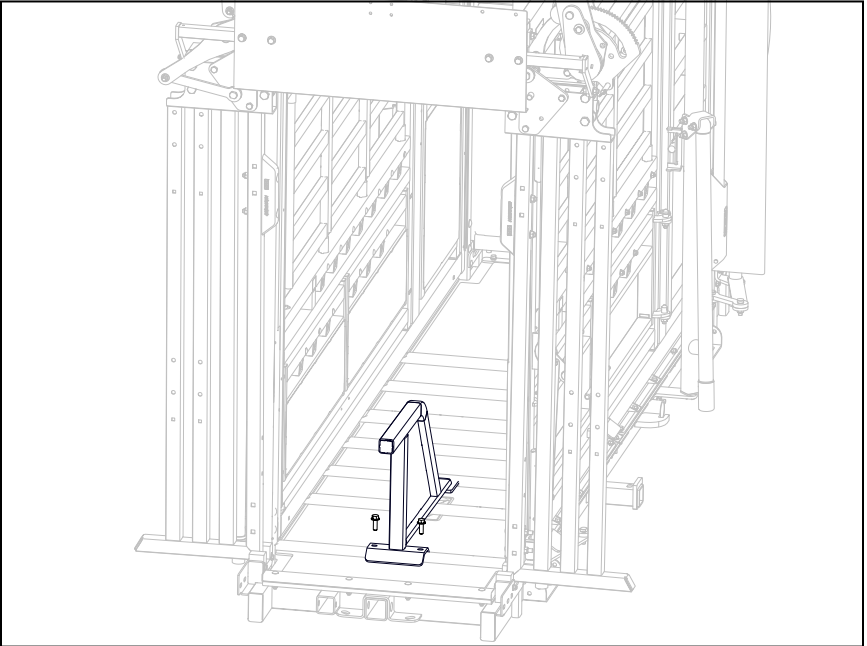

WHEEL KIT [75WK]

REQUIREMENTS:

- (Optional for jacks) Drill with 1/2" deep socket

JACK OPERATION:

Arrowquip Jacks have a removable handle allowing you to quickly run the jacks up and down with a drill instead of manually cranking the jack. It is important to use a deep socket that extends past lynch pin hole on the jack handle to prevent damage.

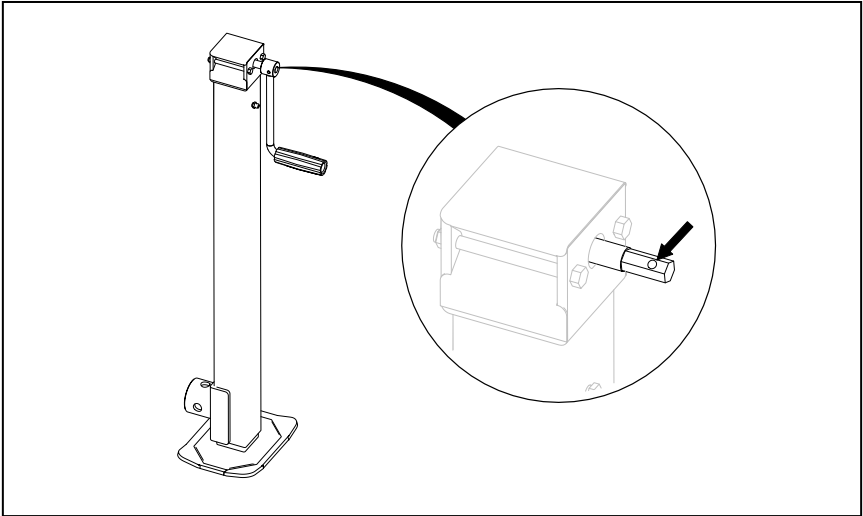

WARNING:

Never use an impact driver! An impact driver will damage jack internals.

Turning the jack clockwise will extend the jack, while turning the jack counterclockwise will retract the jack.

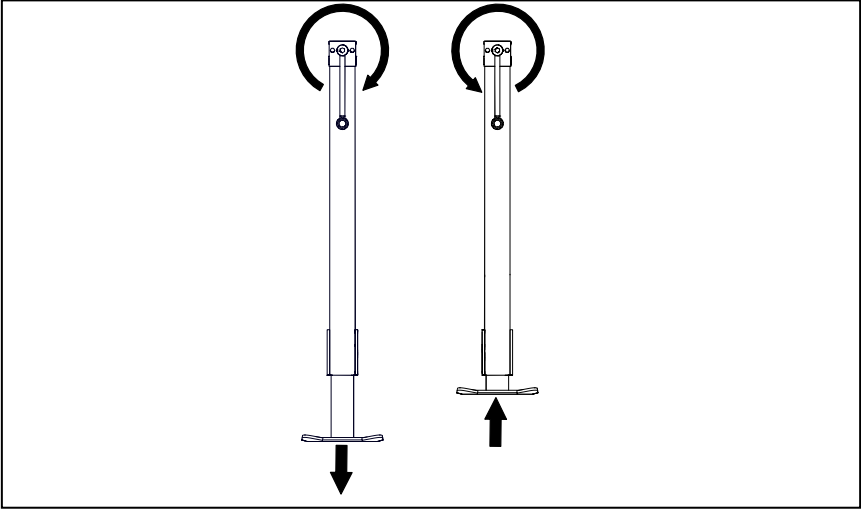

INSTALLATION:



THE CHUTE MUST BE FLAT ON THE GROUND BEFORE PROCEEDING.

NOTE: The below instructions show the 75WK Wheel Kit being installed on a Powerlock 1075 Series Chute. The process for installation is the same for all other compatible chutes.

1. Mount the jack adaptor to the front of the chute.

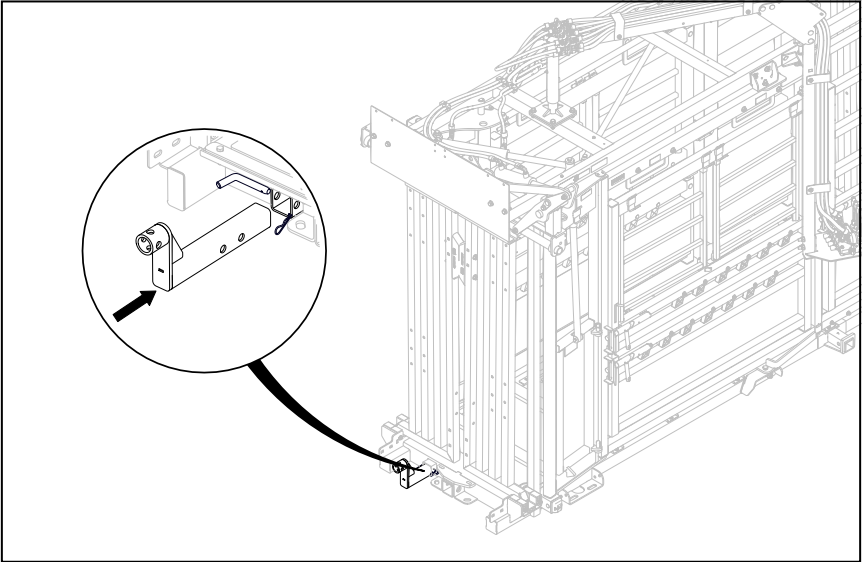

2. Install both jacks on the mounts located on each side near the rear of the chute. Secure jacks to chute with attached pin.

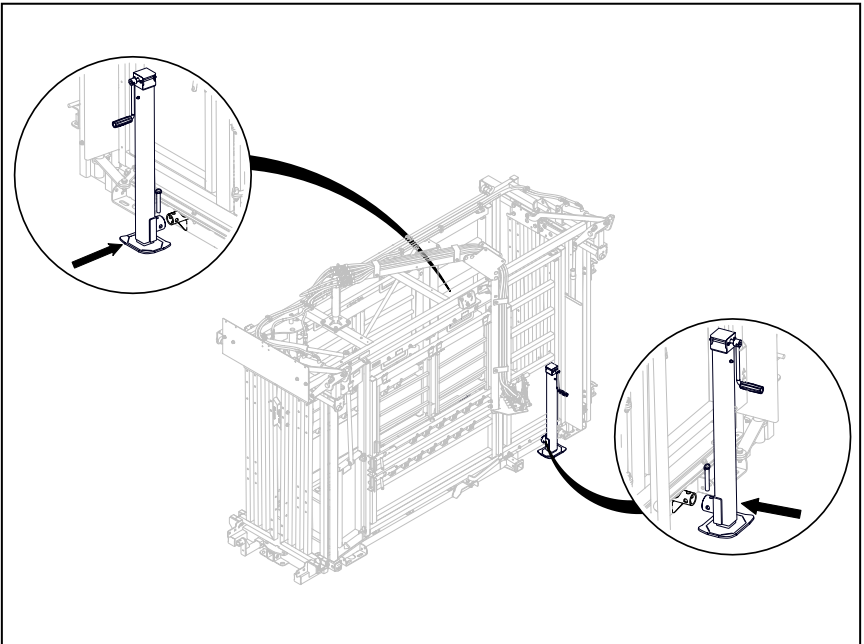

3. Use the jack to raise one side of the unit approx. 6" off the ground.

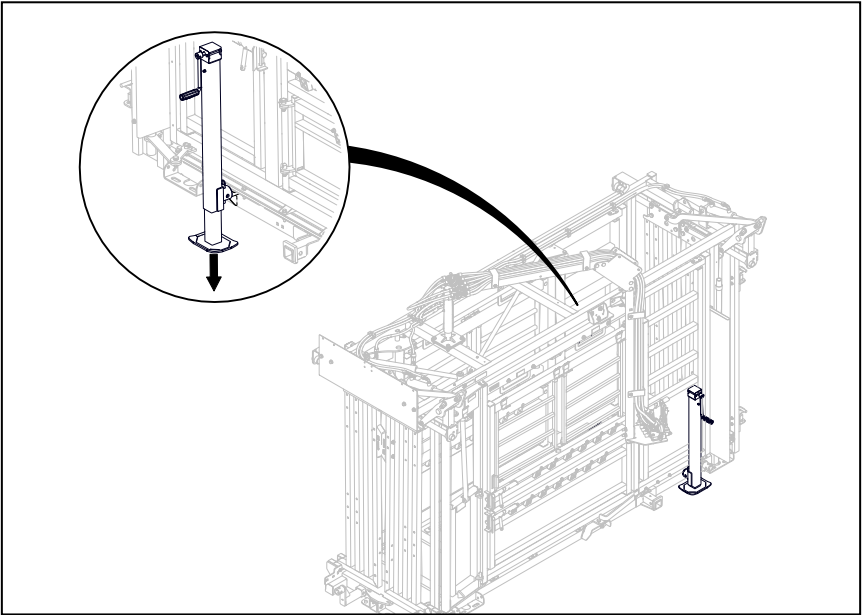

4. Raise the opposite side of the unit enough to install the wheel.

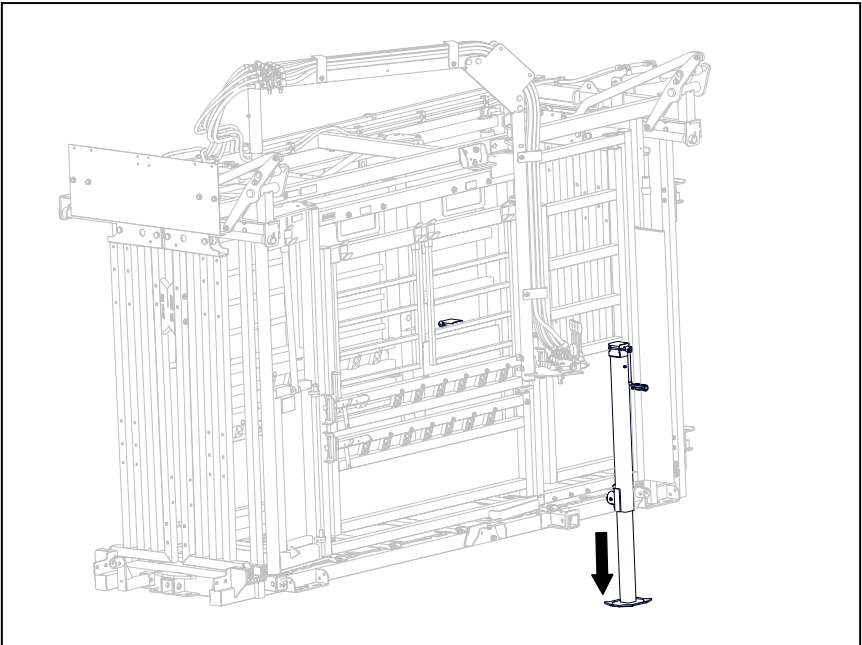

5. Install the wheel and secure with transport pins.

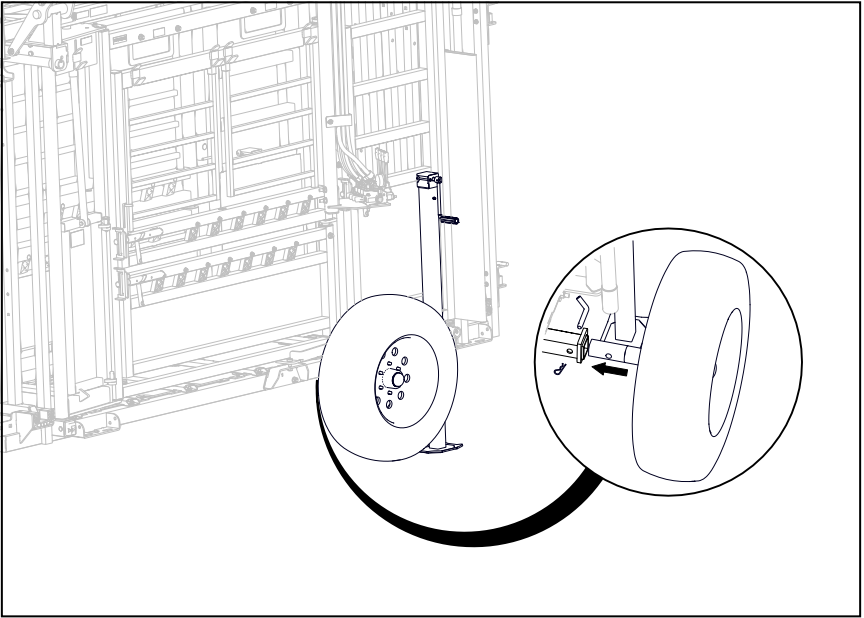

6. Raise the opposite side of the unit enough to install the other wheel.

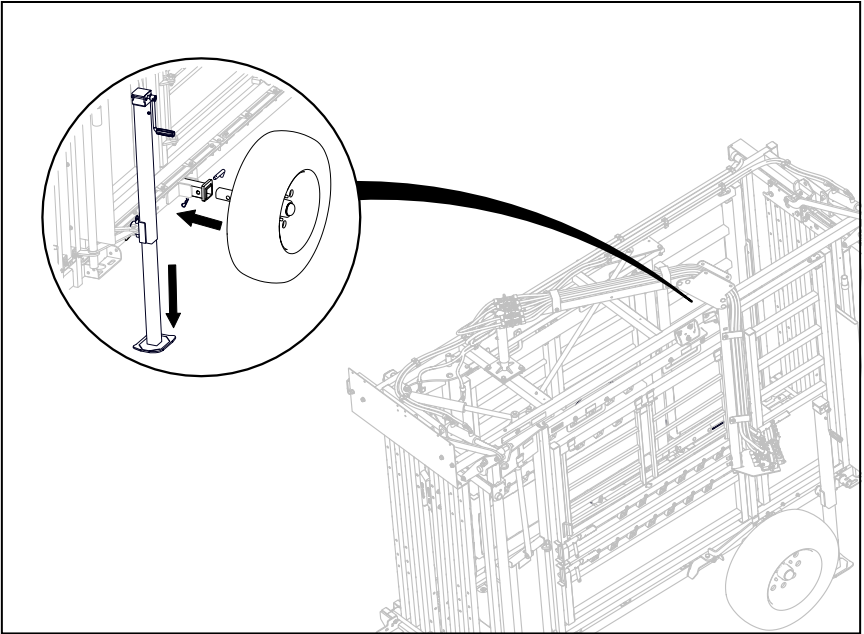

9. Use the front jack to raise the chute off the ground enough to install the hitch.

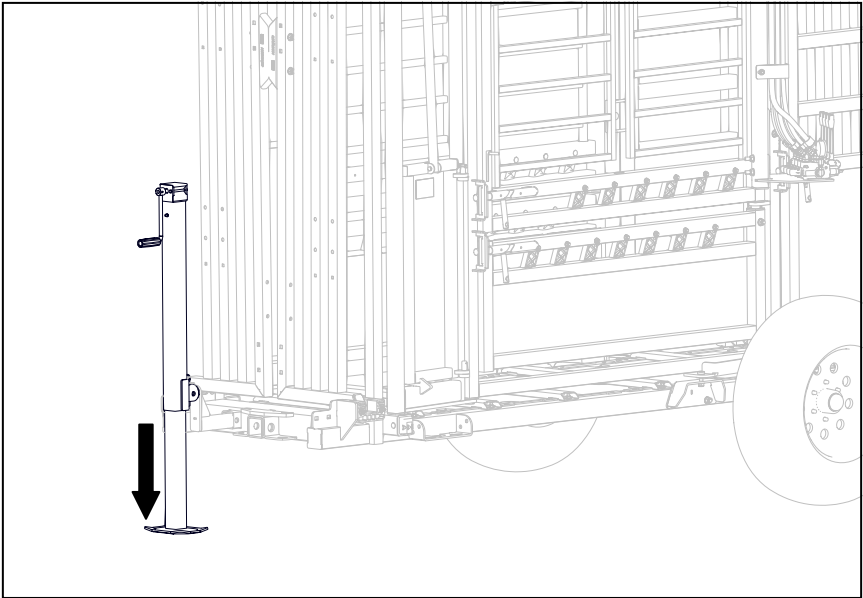

10. Install the hitch and secure with the pin.

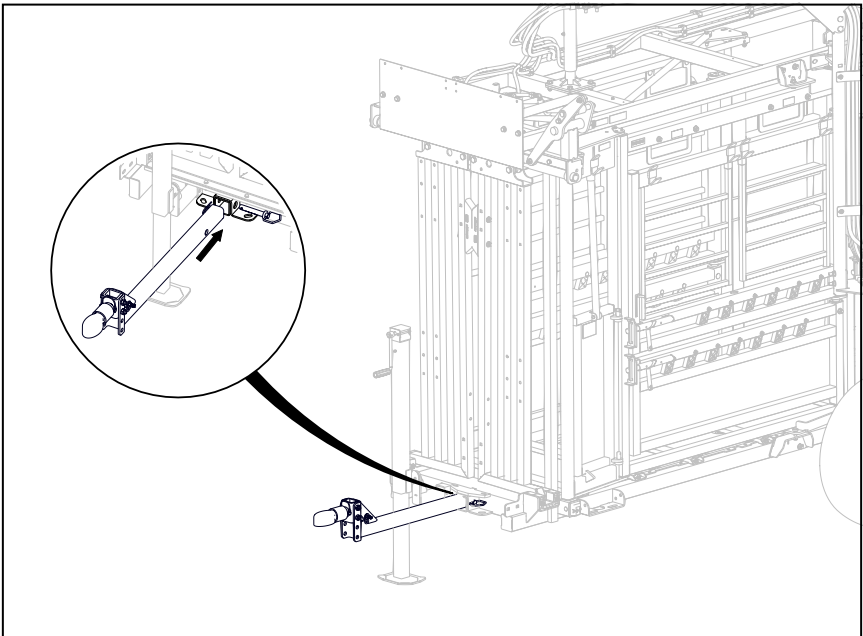

11. Attach the unit to the towing vehicle. Adjust the jack to move hitch to the proper position for the vehicle, if necessary.

NOTE: ENSURE SAFETY CHAINS PROVIDED HAVE BEEN ATTACHED TO THE UNIT.

12. Retract the front jack foot completely.

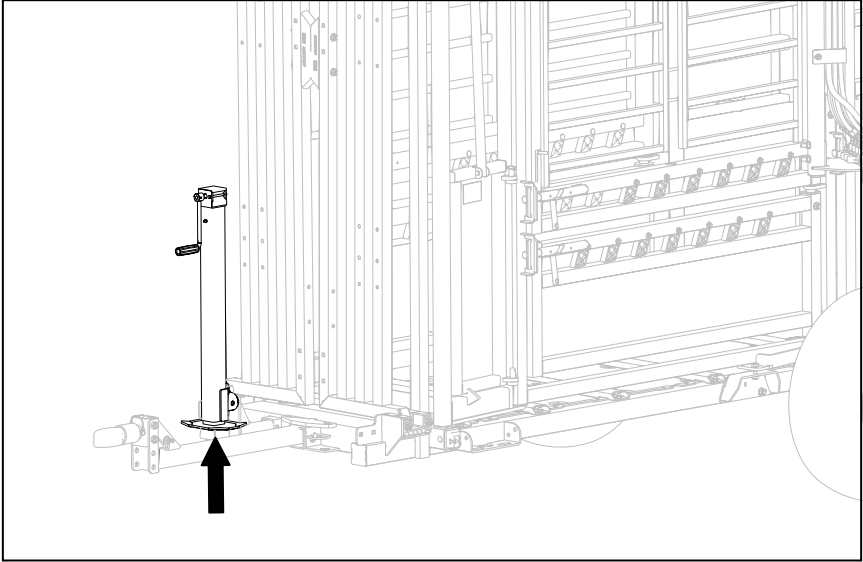

SAFETY CHECK:



- Jacks are retracted completely.
- All doors and gates are shut.
- Tires are in good condition.

MAXIMUM SPEED: 50 KPH / 30 MPH

REMOVAL:



ENSURE YOU ARE DISCONNECTING THE CHUTE ON FIRM, LEVEL GROUND BEFORE PROCEEDING.

1. Extend front jack until the hitch is free from the towing vehicle.

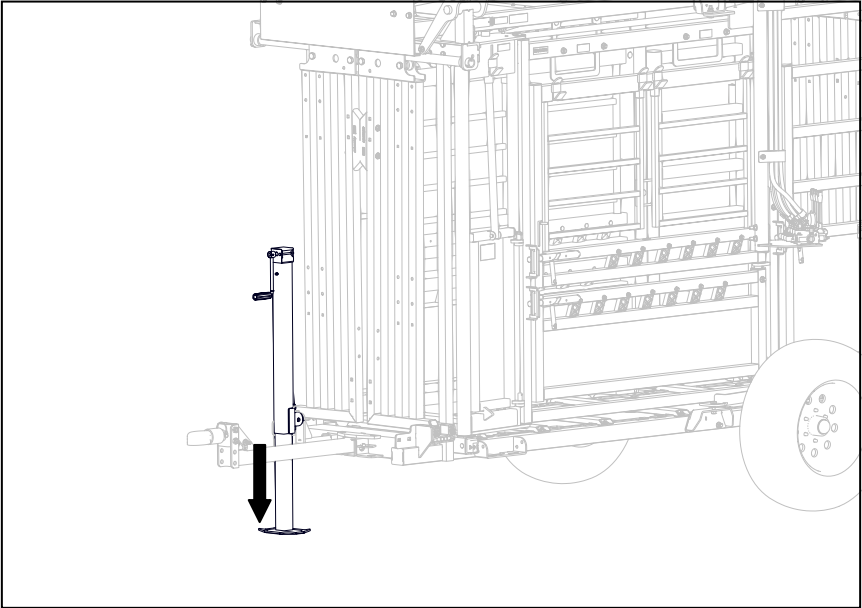

2. Remove the hitch.

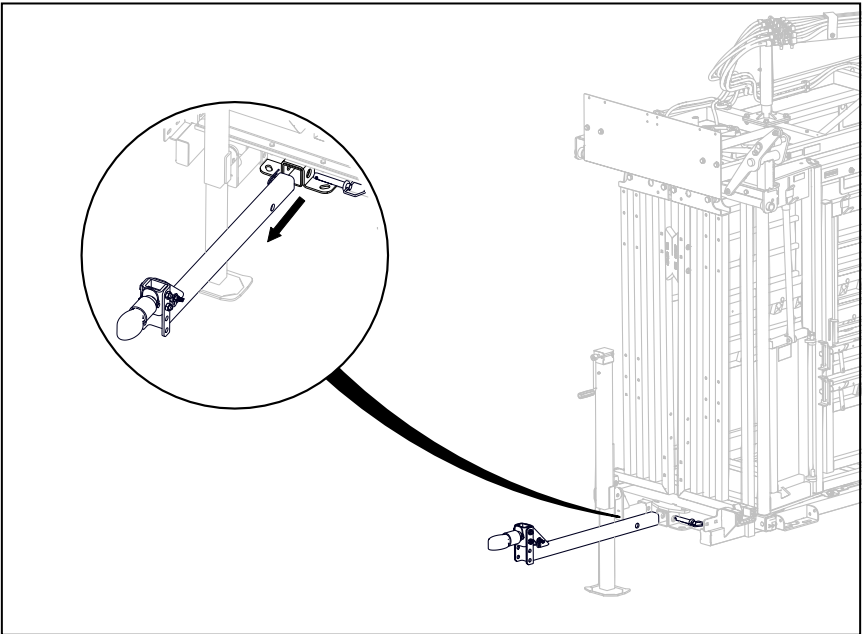

3. Using the jack, lower the chute to the ground. Remove jack from the chute.

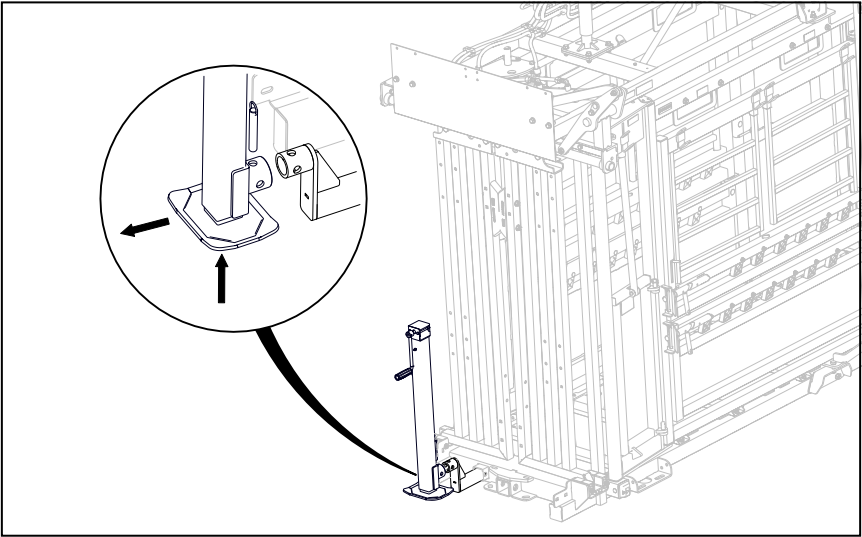

THE FRONT SECTION OF THE CHUTE MUST BE LYING FLAT ON THE GROUND BEFORE PROCEEDING.

4. Transfer the front jack to the rear mount.

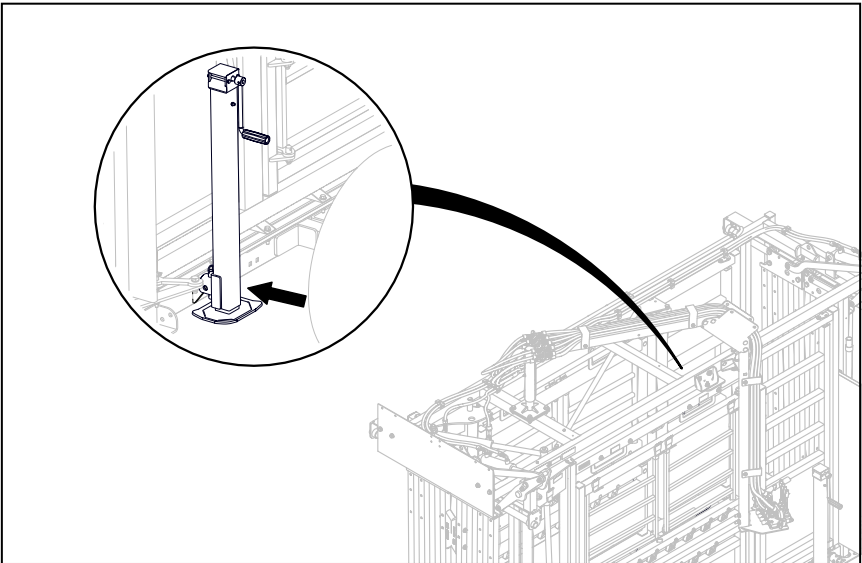

5. Extend the jack on one side of the unit until high enough to remove the wheel. Safely set the wheel aside.

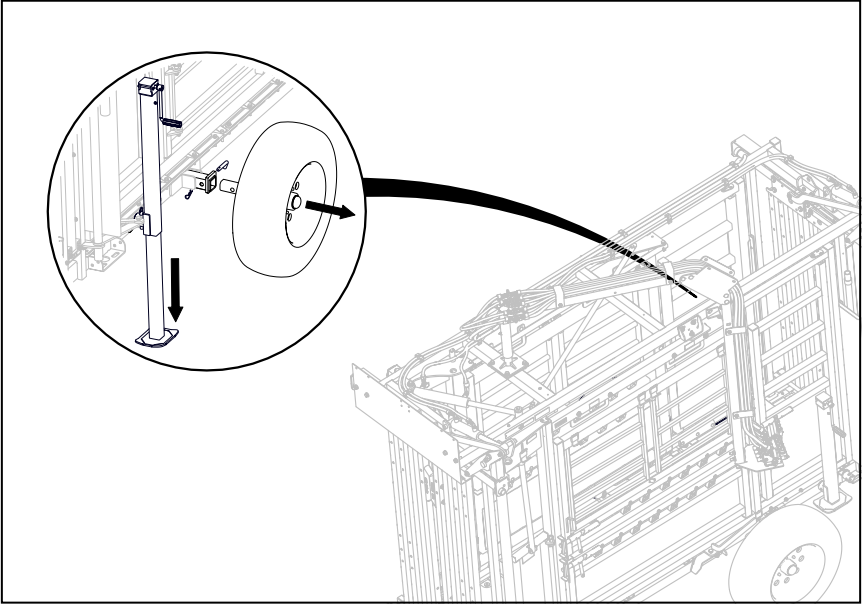

6. On the opposite side, jack the unit all the way up. Remove the wheel and set safely aside.

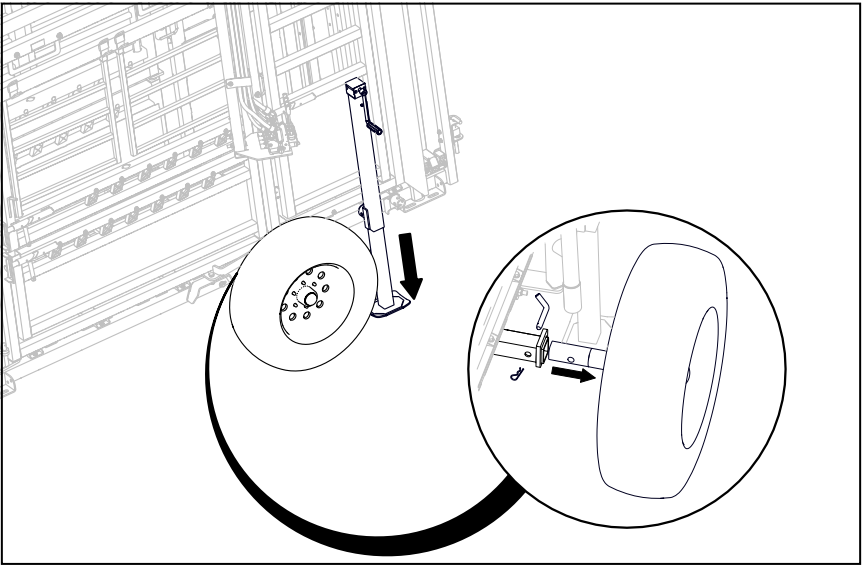

7. Retract one jack until it is only extended about 6".

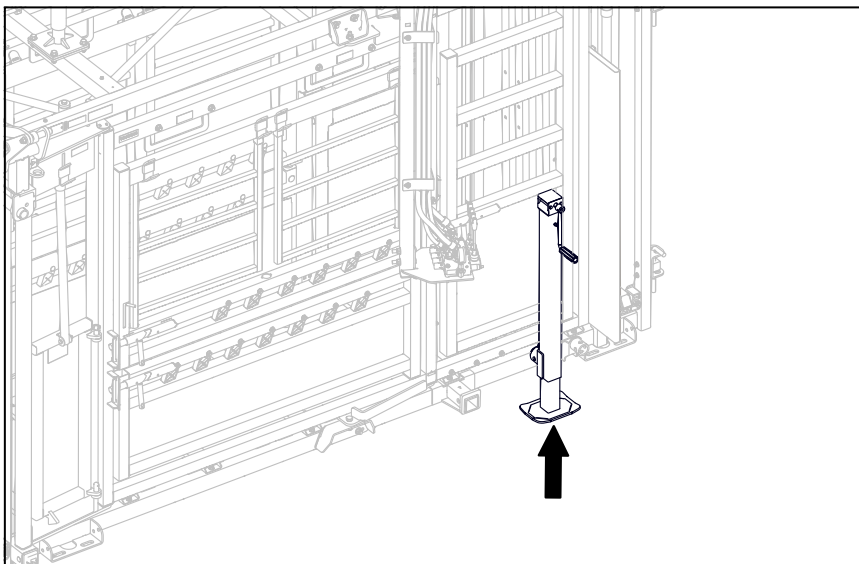

8. Retract the other jack completely, remove from mount and set safely aside.

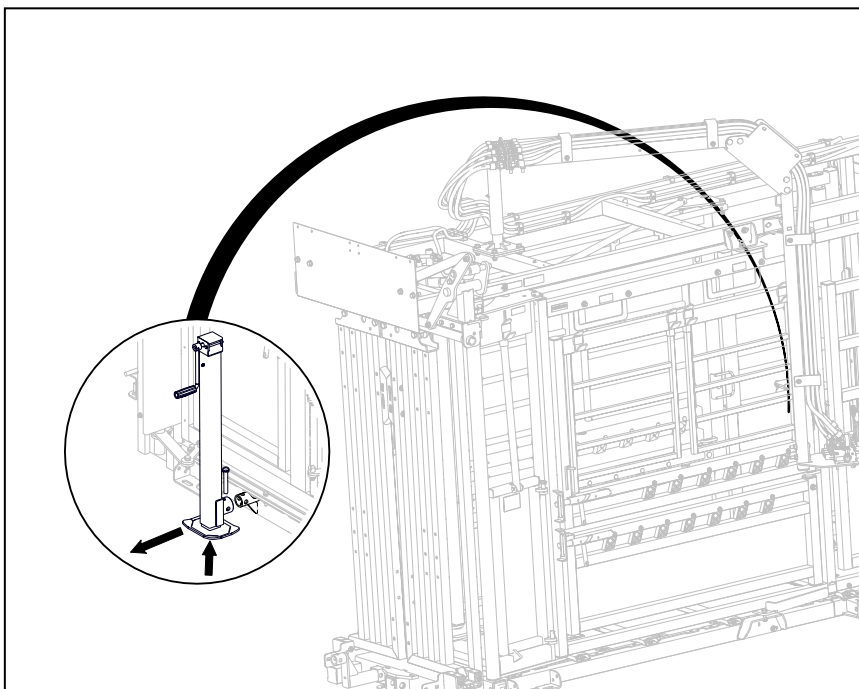

9. Retract the opposite jack the rest of the way then remove the jacks and front jack adaptor. Set aside.

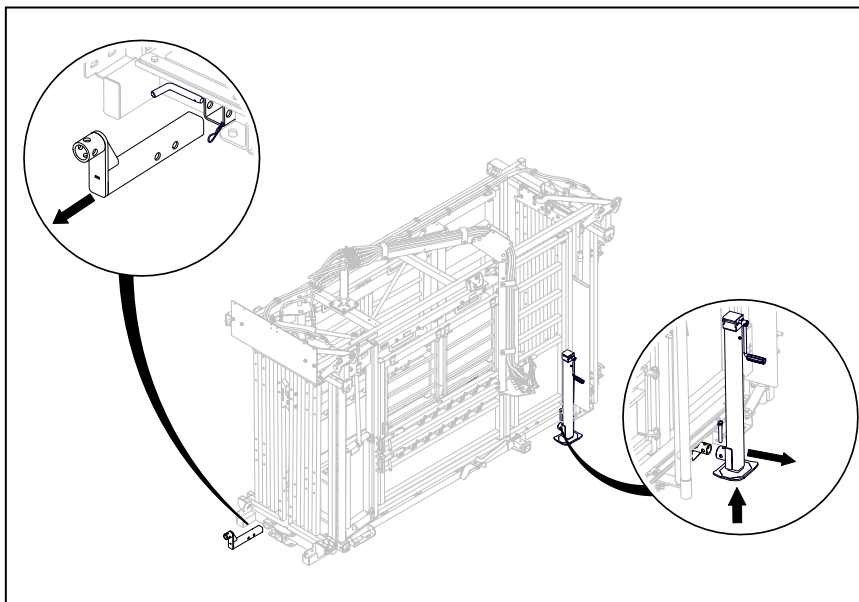

SAFETY CHECK:



- Inspect for damages due to transport.
- Head gate and squeeze mechanisms are functioning properly.
- All latches on doors, gates, and panels are functioning properly.
- When applicable, all add-ons are properly installed and functioning.

WHEEL MAINTENANCE

Pressure

The pressure in the tires from factory will be around 80 PSI.

For an improved towing feel reduce air pressure to recommended value depending on the product:

- **ARROWLOCK AND POWERLOCK CHUTES:** 40 PSI
- **ARMY SERIES CHUTES:** 50 PSI

Torque

Lug nuts should be tightened to 120 ft. Lbs.

A torque wrench is recommended to make sure fasteners are tightened properly.

Be sure to use only fasteners matched to the cone angle of your wheel – usually 60° or 90°.

To properly attach wheels:

1. Start all bolts or nuts by hand to prevent cross-threading.
2. Spin lug nuts all the way down until rim is seated against the wheel hub. Tighten lug nuts to 120 ft. lbs. in cross sequence as shown below.



3. Torque the wheel nuts/bolts before first road use and after each wheel removal. Check and re-torque after 50 miles. Check periodically thereafter.



If you have any questions regarding your product or require assistance, please contact Arrowquip's Client Care Team at **1-877-275-6075** or by email at **cs@arrowquip.com**

arrowquip.com

