

PRODUCT MANUAL

POWERLOCK 108 SERIES

PORTABLE WORKING SYSTEMS

10818 | 1088



MAY 2026 | 2026492

1-877-275-6075
cs@arrowquip.com
arrowquip.com



WARNING:

PLEASE FOLLOW ALL SAFETY INSTRUCTIONS PROVIDED IN THIS MANUAL BEFORE OPERATION. ARROWQUIP DOES NOT ACCEPT RESPONSIBILITY FOR ANY ACCIDENTS OR INJURY WHEN THIS SAFETY MANUAL HAS NOT BEEN READ IN FULL AND KEPT WITH THE PRODUCT AT ALL TIMES. OPERATORS OF THIS PRODUCT TAKE AND ACCEPT RESPONSIBILITY FOR ANY HARM OR INJURY TO THE ANIMAL OR OPERATOR WHEN IT PERTAINS TO HOW THE EQUIPMENT IS USED AND MAINTAINED.

Please keep this manual for frequent reference and to pass on to new users or owners.

CONTENTS

SAFETY PRECAUTIONS.....	6
SAFETY GUARANTEE.....	7
RISK ASSESSMENT.....	8
TRANSPORTING THE POWERLOCK 108 SERIES PORTABLE WORKING SYSTEM.....	9
REFERENCE FOR MANUAL JACKS.....	9
REFERENCE FOR TUB INSTRUCTIONS.....	10
OPERATION GUIDE FOR HYDRAULIC JACKS.....	11
TO LOWER THE UNIT FOR USE.....	13
UNFOLDING THE COLLAPSIBLE TUB.....	16
FOLDING THE COLLAPSIBLE TUB.....	23
INSTALLING TIRES.....	30
POWERLOCK 108 SERIES CATTLE CHUTE.....	33
SETTING UP THE HYDRAULIC CATTLE SQUEEZE CHUTE.....	33
GAS POWER PACK.....	34
ELECTRIC POWER PACKS.....	35
OPERATING THE POWERLOCK CATTLE CHUTE.....	36
COLD START.....	36
POWER FAILURE.....	36
POWERLOCK 108 SERIES ADD-ONS.....	37
LUG POSTS.....	40
BALK GATE.....	43
SHEETED STERNUM BAR.....	46
CALF RESTRAINER BAR.....	48
HYDRAULIC HEAD SWEEP.....	50
HYDRAULIC NECK EXTENDERS.....	50
HYDRAULIC NECK EXTENDERS.....	50
EASY FLOW ALLEY SECTION.....	51
ADJUSTING THE EASY FLOW ALLEY.....	51
USING THE REMOVABLE SIDE PANELS.....	52
USING THE EMERGENCY EXIT.....	53
SCALE PLATFORM INSTALLATION.....	54
ROLLING DOOR CONVERSION.....	57

COLLAPSIBLE TUB 60

 3E BUDFLOW INSTALLATION 60

 OPERATING GUIDELINES 81

 USING THE 3E BUDFLOW TUB 81

RECOMMENDED MAINTENANCE 82

 MAINTENANCE SAFETY 82

 REGULAR MAINTENANCE 82

 HYDRAULIC MAINTENANCE 83

 POWER PACK MAINTENANCE 83

 HYDRAULIC JACK MAINTENANCE 83

 BATTERY MAINTENANCE 83

 BATTERY REPLACEMENT 83

WHEEL MAINTENANCE 84

TROUBLESHOOTING GUIDE 85

 SQUEEZE CHUTE 85

 108 SERIES POWER PACK TROUBLESHOOTING 86

 GAS POWER PACK ISSUES 86

 ISSUES WITH ELECTRIC POWER PACK 87

 HYDRAULIC JACKS 87

 MANUAL JACKS 88

RECOMMENDED USE 89

WARRANTY 90

SAFETY PRECAUTIONS

PLEASE FOLLOW ALL SAFETY INSTRUCTIONS PROVIDED IN THIS MANUAL BEFORE OPERATION. ARROWQUIP DOES NOT ACCEPT RESPONSIBILITY FOR ANY ACCIDENTS OR INJURY WHEN THIS SAFETY MANUAL HAS NOT BEEN READ IN FULL AND KEPT WITH THE PRODUCT AT ALL TIMES. ANY HARM TO THE ANIMAL OR INJURY TO THE OPERATOR WHICH OCCURS DUE TO HOW THE PRODUCT IS OPERATED, OR RESULTING FROM A LACK OF SAFETY PRECAUTIONS ARE THE SOLE RESPONSIBILITY OF THE OPERATOR.

All farm machinery and equipment are potentially dangerous. Careless use of any Arrowquip livestock equipment may cause injury or damage to persons, cattle, or property. Arrowquip has taken precautions in the design and manufacturing of this product to ensure that it is safe and user friendly. Therefore, the user must assume all responsibility and risk associated with the possession and use of the cattle squeeze chute.

SAFETY GUARANTEE

Arrowquip is committed to creating safe cattle management experiences. With this commitment to safety, in the event any purchaser of Arrowquip equipment is **physically injured while operating the equipment AND requires medical treatment**, Arrowquip will provide a **full refund** of the equipment purchase price and the purchaser will be allowed to keep the equipment. Equipment must be warranty-registered, and the purchaser must read and practice the contents and recommended maintenance and procedures outlined herein to be eligible.

Arrowquip also commits to repair or replace any part of the equipment that is defective, malfunctions or otherwise falls under normal use and inside the equipment's warranty terms. If the equipment requires replacement, it shall be replaced with an identical model or a newer model of the equipment. For further details, visit arrowquip.com/promise.



WARNING:

Read below before operation.

1. Ensure the operator understands the contents of this manual before using the equipment.
2. **DO NOT** wear loose-fitted clothing.
3. Ensure the equipment is on a firm, level, dry surface that is free of rocks and other trip hazards.
4. **DO NOT** enter the vet cage until the animal is secured in the head gate and the rump bar has been placed so that the cow cannot back up.
5. **DO NOT** stand in front of the head gate while operator is moving the cattle through the squeeze chute.
6. **DO NOT ALLOW CHILDREN UNDER THE AGE OF 18 NEAR AN OPERATING MACHINE.**
7. Follow safe cattle handling procedures in other areas of the yard so that cattle are more docile.
8. **DO NOT** make any modifications to Arrowquip equipment. Non-factory modifications to the equipment can reduce the safety for the operator & livestock, and void warranty.
9. **DO NOT ALLOW CHILDREN UNDER THE AGE OF 18 TO USE THE HYDRAULIC EQUIPMENT.**
10. **DO NOT** operate hydraulics while operators are working with the cattle in the chute or are touching the chute. Reaching out or into the chute while hydraulics are in operation can result in serious injury.
11. Please ensure that all hydraulic hoses and electrical leads are out of the way and safely positioned before moving cattle or using the chute.
12. Keep a distance of more than an arm's length from the hydraulic chute while hydraulics are in operation.

RISK ASSESSMENT

1. Conduct a risk assessment on procedures for which the equipment is used and establish a safe work procedure.
2. Ensure all users of the equipment have been inducted and comply with safe working procedure.
3. Ensure that the equipment is on firm, level ground.
4. Ensure that there are NO hazardous hydraulic cords or large objects within or around the equipment where cattle and operator will be.
5. Please ensure that all hydraulics work properly before putting cattle through the chute.
6. Please make sure that all hydraulic hoses are properly secured to the hydraulic pump or tractor.
7. Ensure that the hydraulic controls are functioning properly. Specifically ensure that the adjustable side mechanism and the head gate are adjusting smoothly.
8. If hydraulics do not function properly when testing the equipment, **DO NOT** put cattle through the chute.
9. Ensure that access gates are closed securely before running cattle through the chute.
10. Some chemicals and medicines can damage powder coat. Take all precautions and wash after use.
11. Make sure your equipment has been cleared of **ALL** livestock after use.
12. Some chemicals and medicines can damage powder coat. Take all precautions and wash after use.
13. Maximum towing speed 40km/25mph
14. Maintain tire pressure of 80 psi.
15. Check wheel lug nuts after 10, 25, 50 miles of use, ensure torqued to 120 ft. lbs.
 - a. This applies to first time use and wheel changes.

TRANSPORTING THE POWERLOCK 108 SERIES PORTABLE WORKING SYSTEM



WARNING:

Follow all instructions outlined herein carefully to ensure operator safety when setting up for use or transport.

REQUIREMENTS:

- Level ground
- 2 people

REFERENCE FOR MANUAL JACKS

Your unit will either come with manual or hydraulic jacks, with both represented in this manual. For manual jack control, refer below:

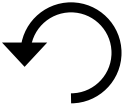

JACK UP



JACK DOWN

REFERENCE FOR TUB INSTRUCTIONS

Use this as a guide when folding and unfolding the collapsible tub.

10818-BF

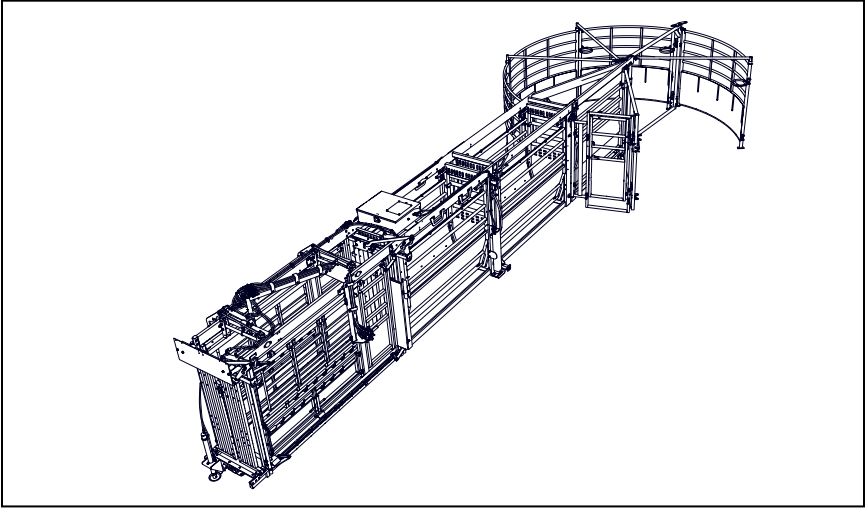

10818-CROWDING

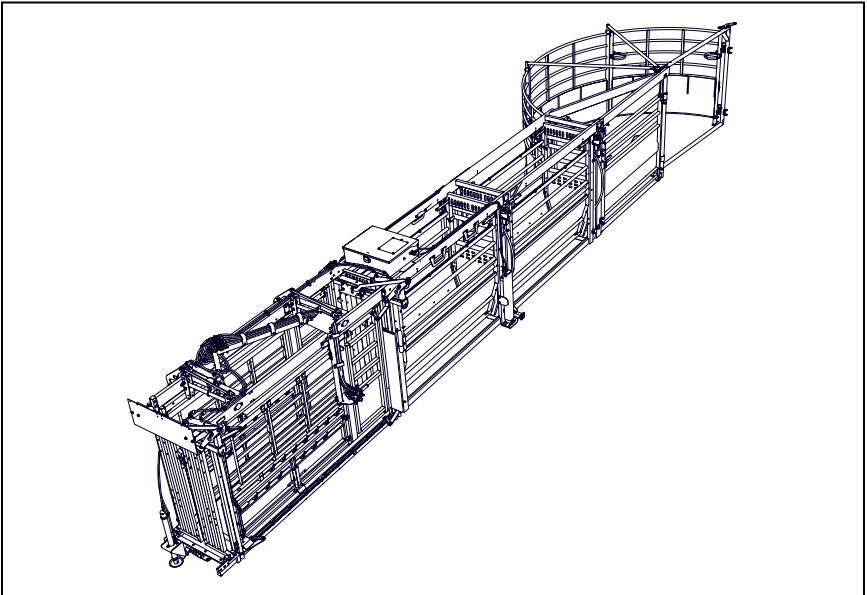

OPERATION GUIDE FOR HYDRAULIC JACKS

Refer to this guide to ensure safe operation of your Hydraulic Jacks.

1. Control pendant has four buttons marked with **F UP** and **F DOWN** for the front jacks, and **R UP** and **R DOWN** for the rear jacks. Refer to decal for directions.
 - a. Note:
 - **DOWN** means you are engaging the jacks.
 - **UP** means you are retracting the jacks.
2. When chute is not attached to a vehicle, lower to the ground for safety.
3. Only lift the unit from firm, level ground.
4. Never raise the unit more than is necessary to put the tires on.



WARNING IMAGE:

BOTH JACKS ARE RAISING THE UNIT.

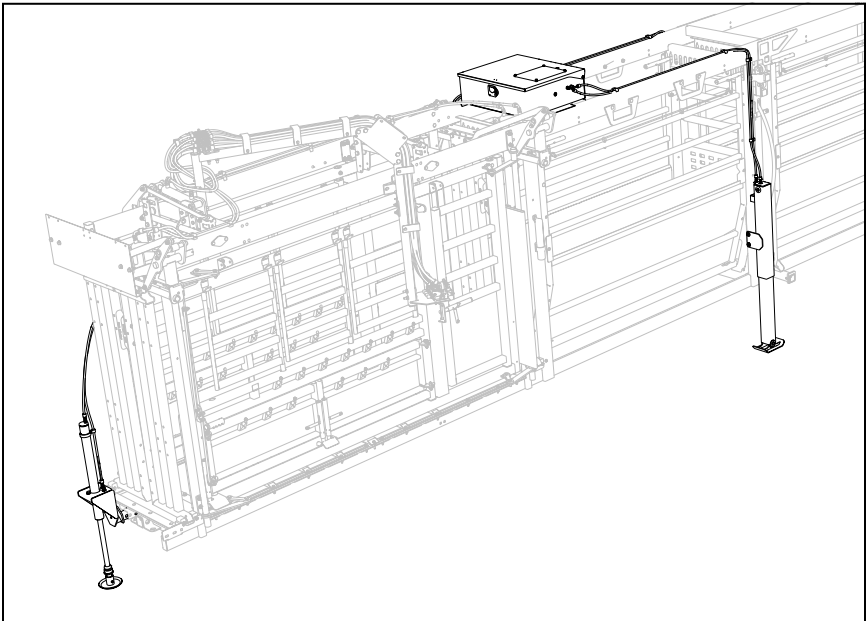



WARNING IMAGE:

ONLY ONE JACK IS RAISED.

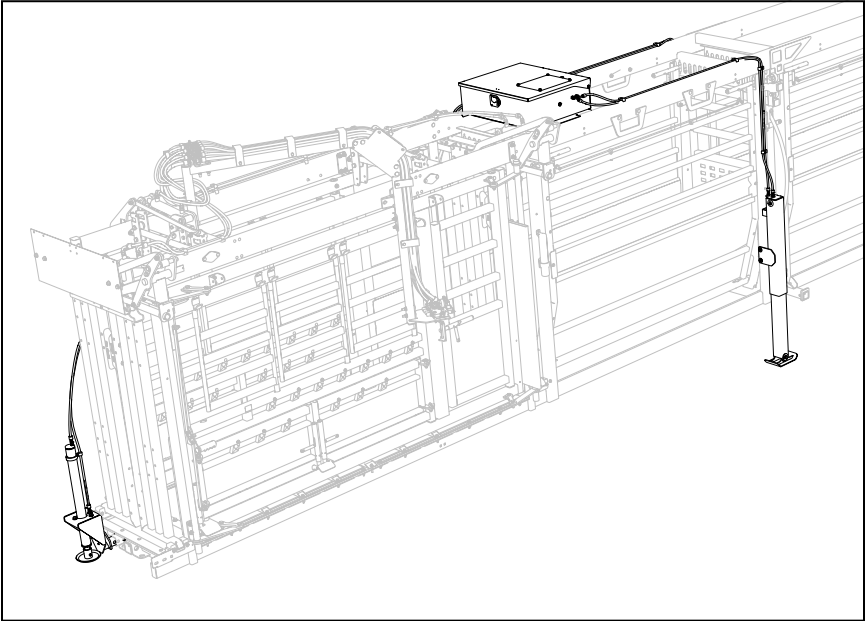

If you have any questions, please contact Client Care at 1-877-275-6075 for assistance.

TO LOWER THE UNIT FOR USE

REMOVING TIRES

1. Raise front jack to support chute using **UP** button.

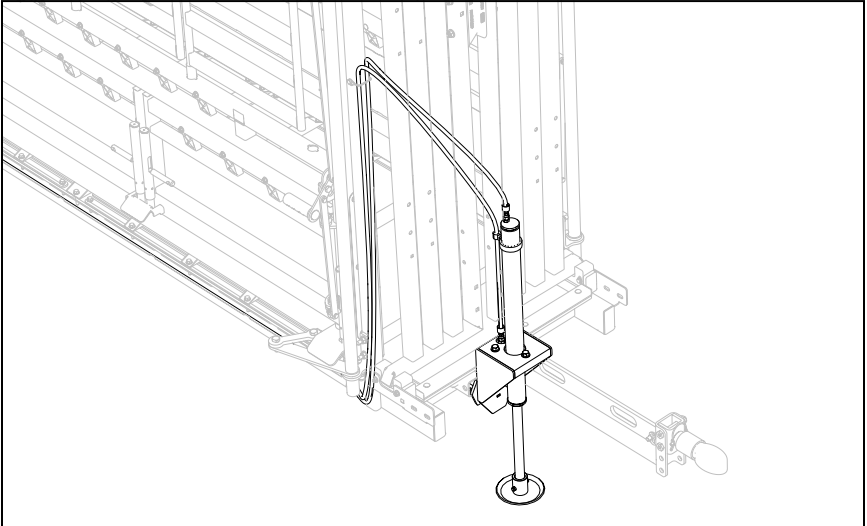

2. Detach chute from truck.
3. Remove hitch and set aside.

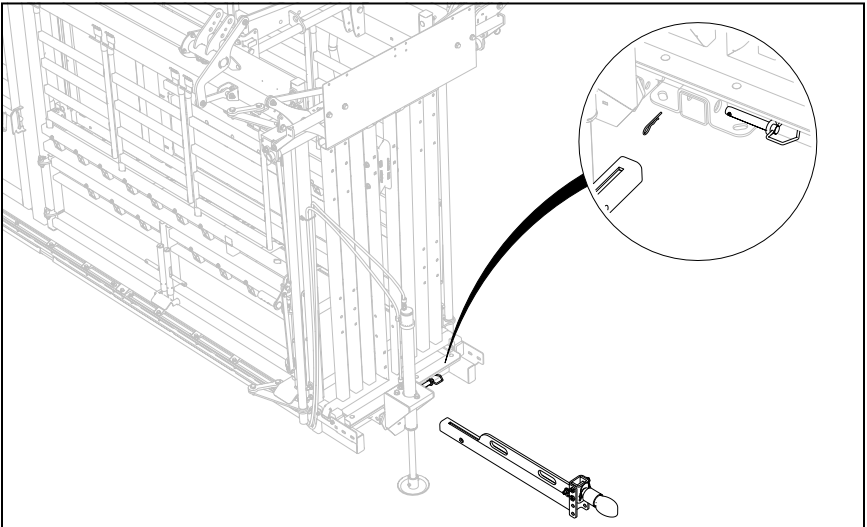

4. Retract front jack using **DOWN** button until the chute rests on the ground.

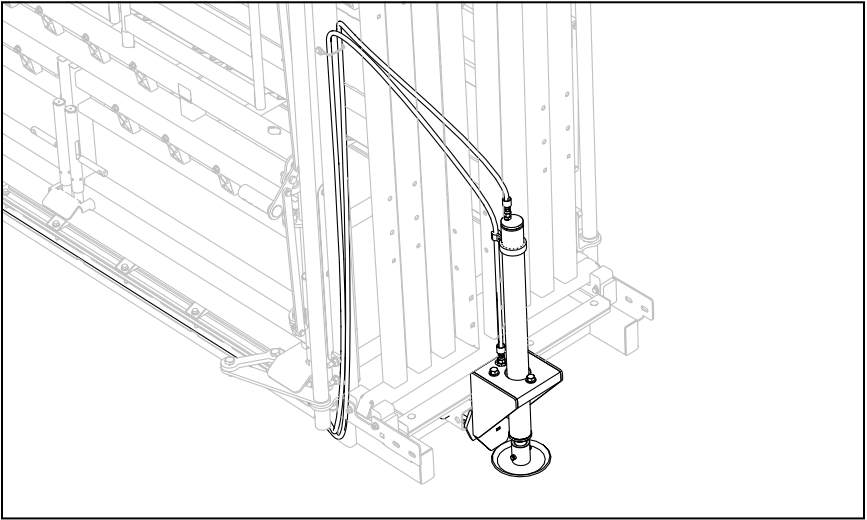

CHUTE SECTION MUST BE FLAT ON THE GROUND BEFORE PROCEEDING.

5. Remove front jack and place aside.

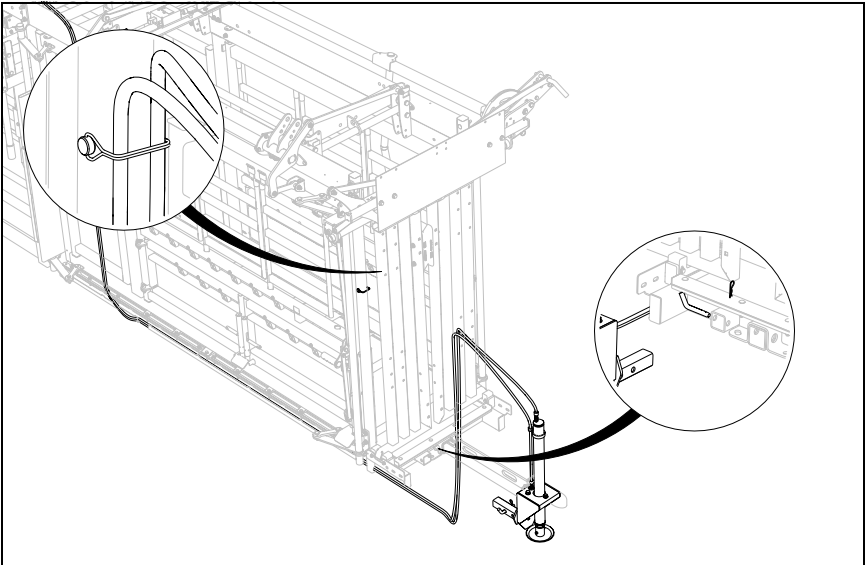

6. Extend rear jacks using **UP** button until tires are off the ground.

7. Remove tires.

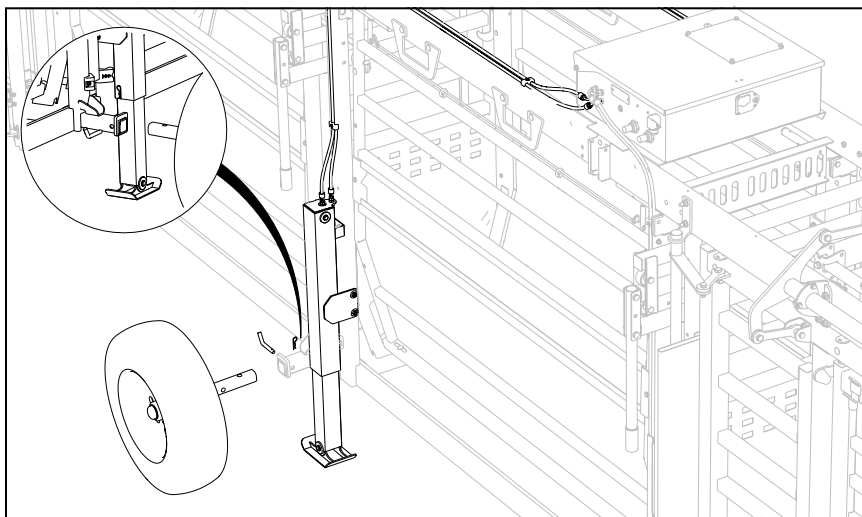

8. Retract rear jacks to set the unit on the ground until they stop retracting using **DOWN**.

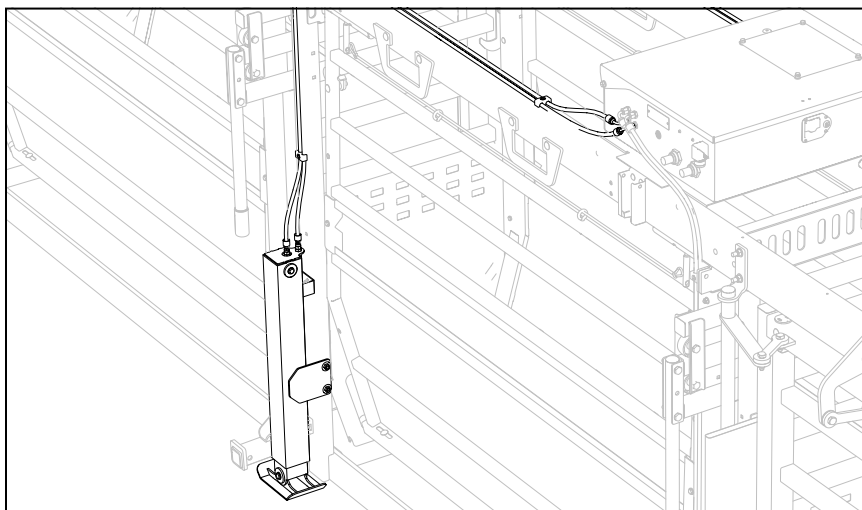

NEXT STEPS:

If your unit has a collapsible tub (10818, 10818-BF), proceed to **UNFOLDING THE COLLAPSIBLE TUB**.

If your unit does not have a collapsible tub (1088), proceed to **OPERATING THE POWERLOCK CATTLE CHUTE ON PAGE 33**.

UNFOLDING THE COLLAPSIBLE TUB

For instructions on how to install the Portable Budflow kit go to page 60.

NOTE: If your unit does not have the budflow option, proceed to step 4.

1. Remove pins and chain.

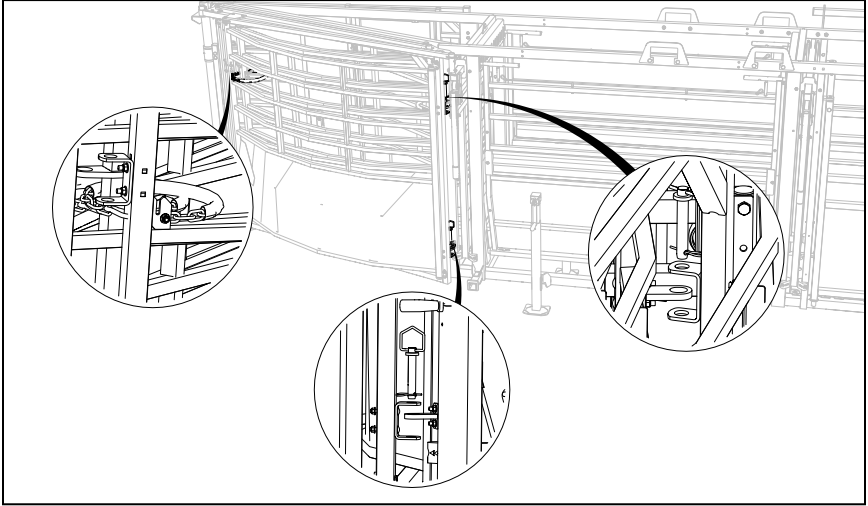

2. Unfold BudFlow panel halfway.

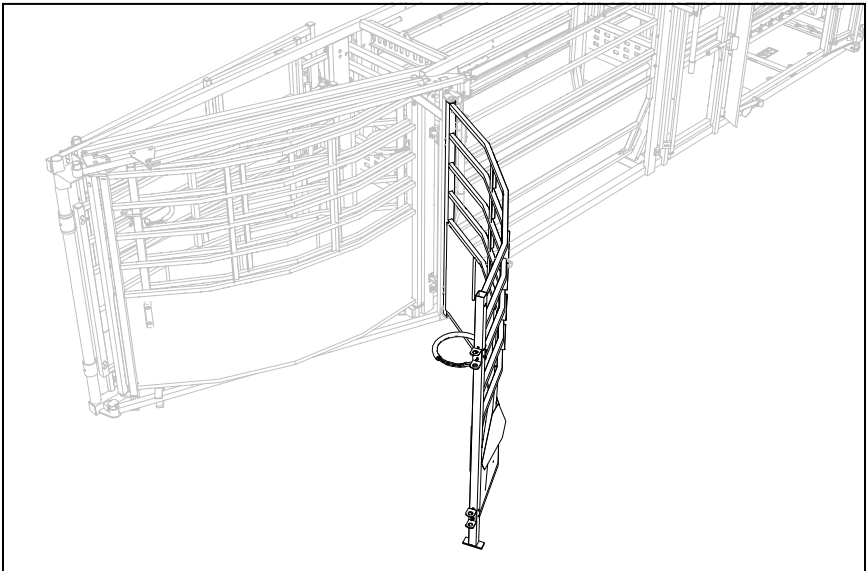

3. Attach top joiner bar to BudFlow frame. Secure with pin.

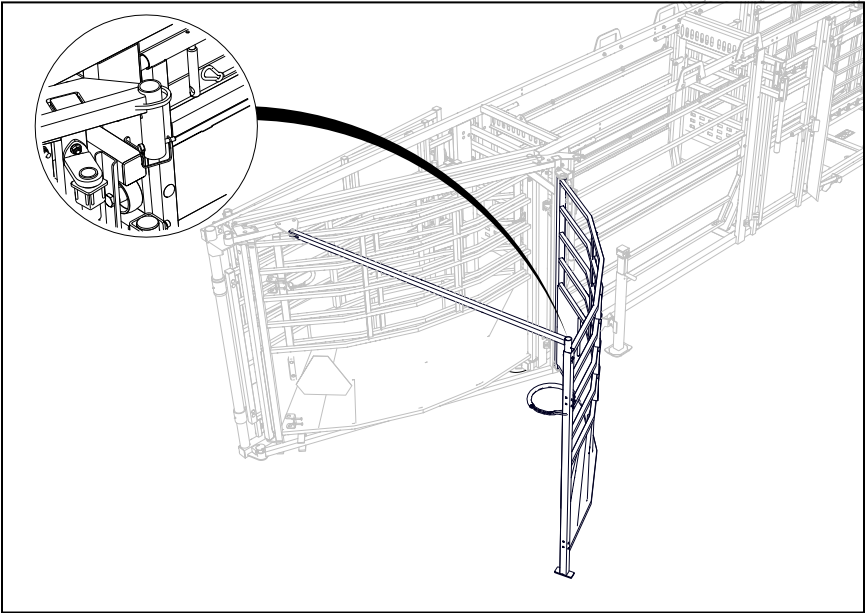

4. Unfold the bow frame all the way out.

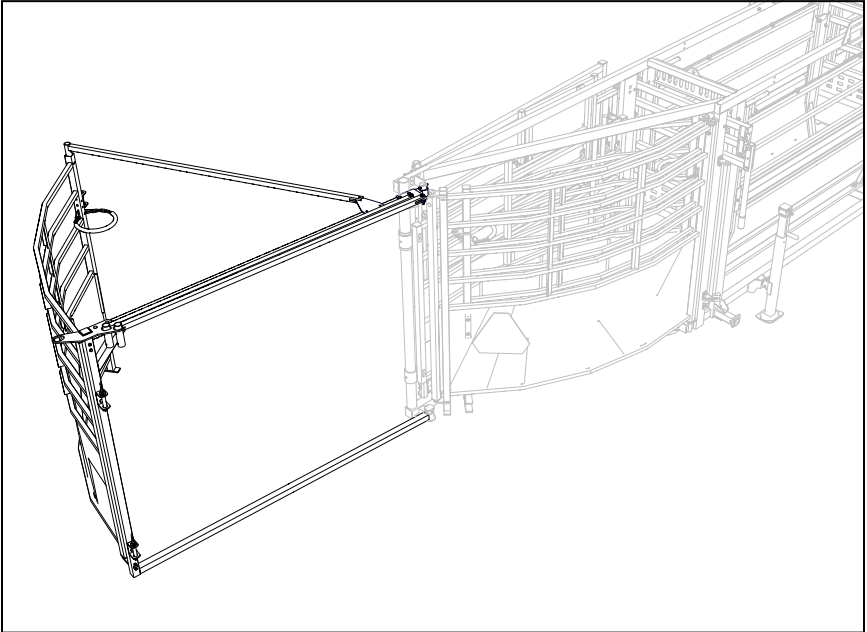

5. Undo the rest of the chains.

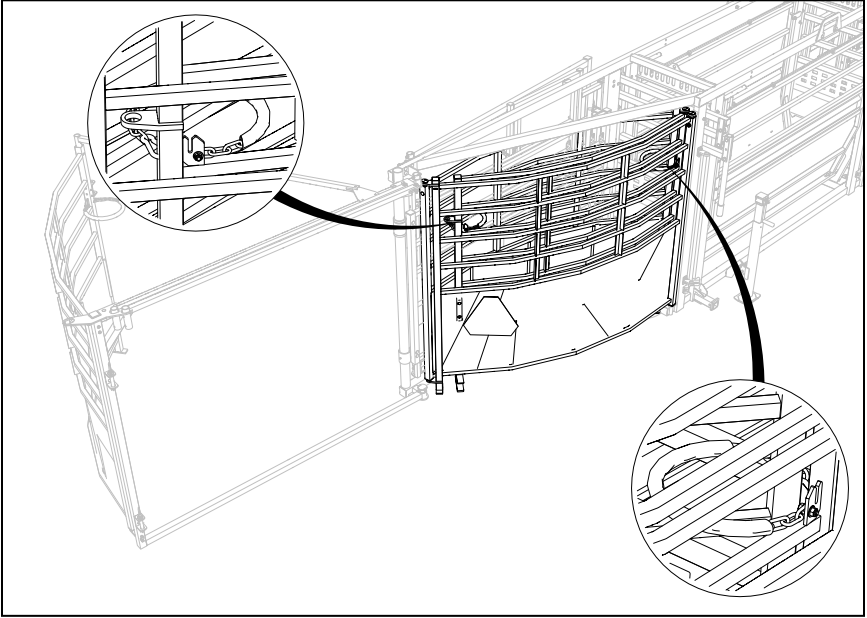

6. Unfold remaining tub panels.

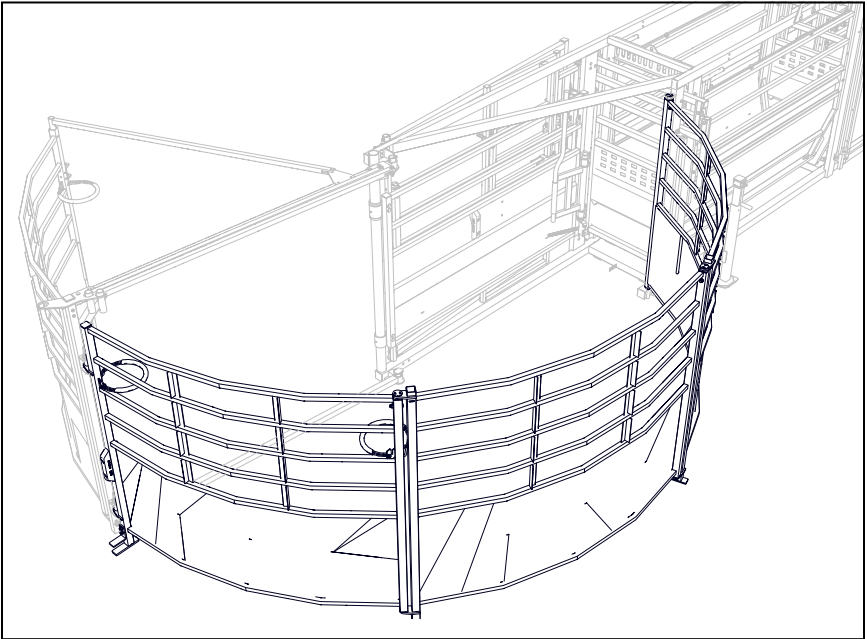

7. Attach joinder bars to the panels as shown and secure with pin.

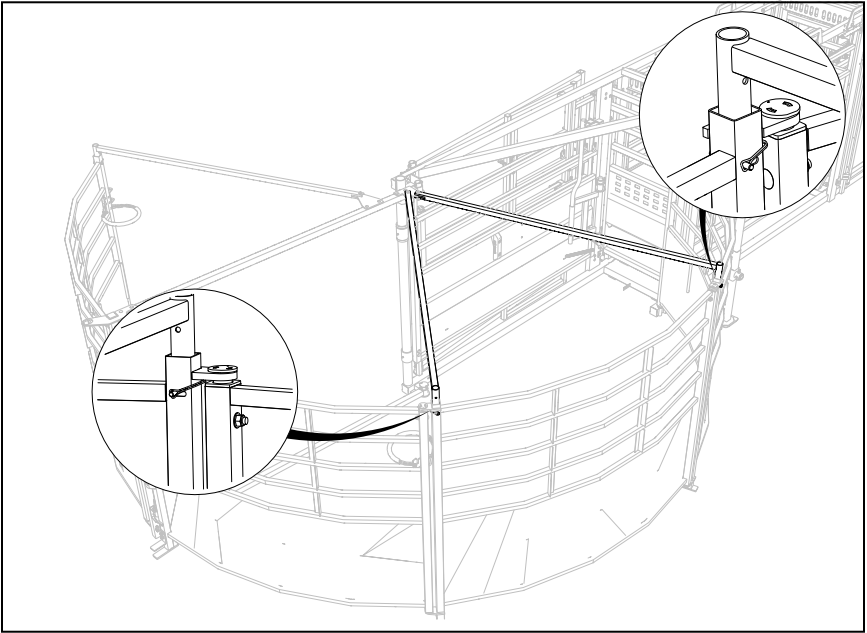

8. Attach tub panels to BudFlow with pin in place.

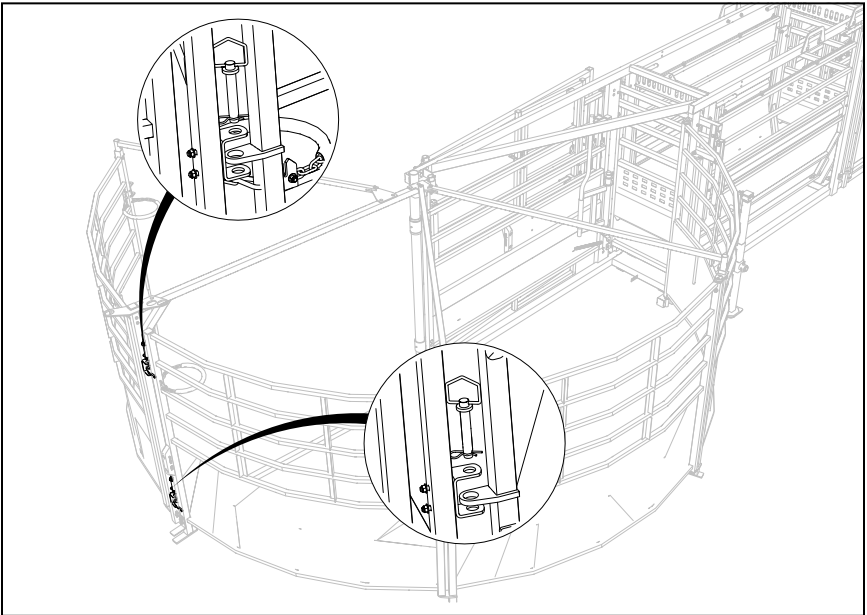

9. 3E Door, remove pins.

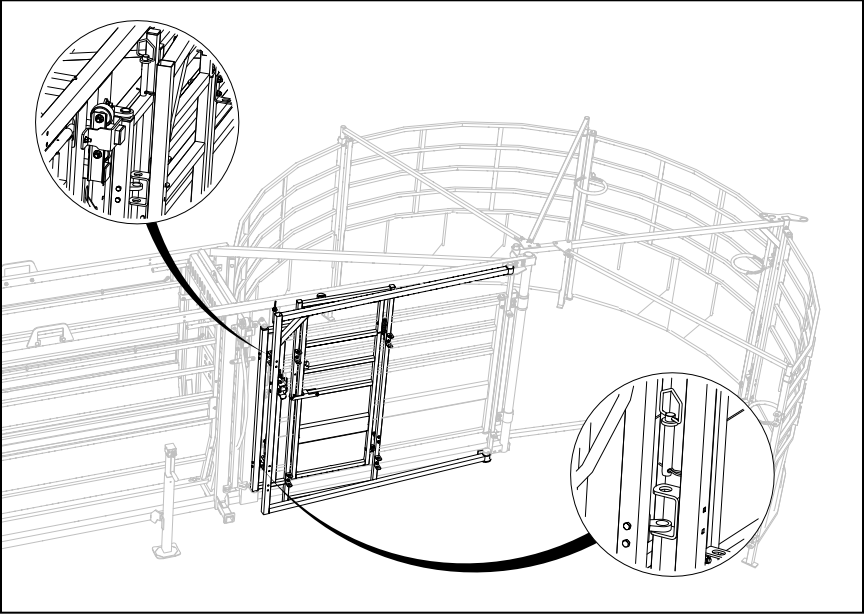

10. To unfold man-door, unfold other bow from the side of the tub.

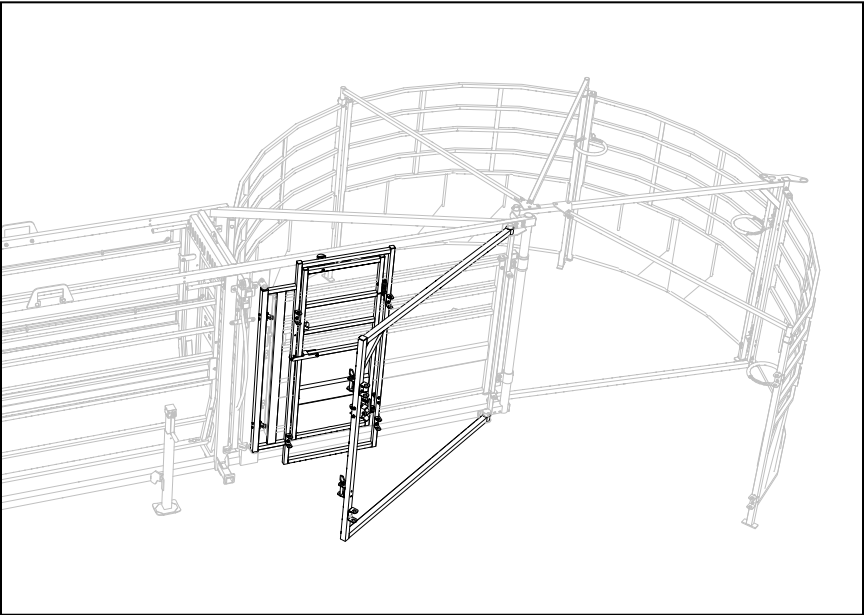

11. Unfold door and attach to bow using panel clips and same pins you just removed.

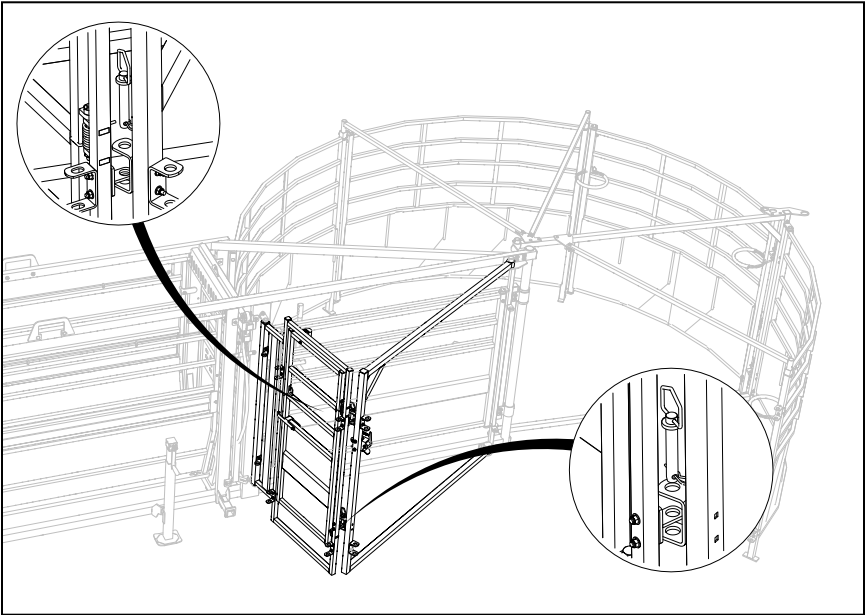

12. Swing the gate out from the side of the tub – it will lock into the bow.

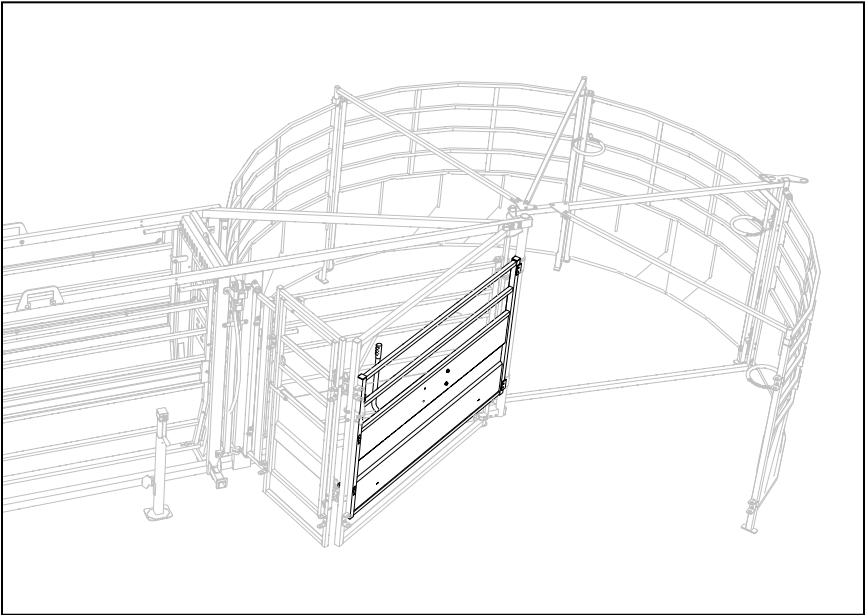

13. **FINAL STEPS:** Lower both jacks completely to the ground.

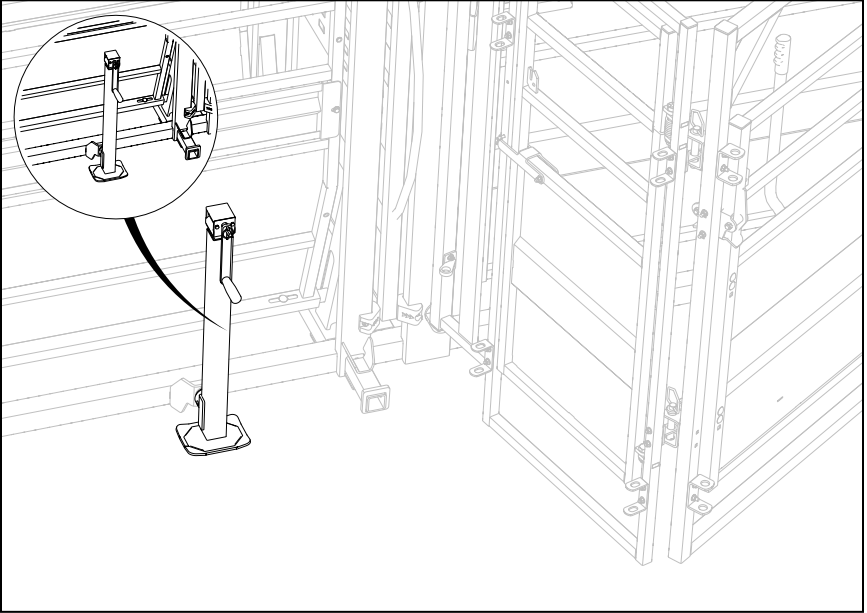

READY FOR USE

FOLDING THE COLLAPSIBLE TUB



SAFETY CHECK:

- All animals have been removed from unit.
- The unit must be flat on the ground before proceeding.

If your unit does not have a collapsible tub (758), proceed to **INSTALLING TIRES ON PAGE 30.**



WARNING:

IF YOU HAVE DIFFICULTY FOLDING YOUR TUB, LIFT THE UNIT A FEW INCHES OFF THE GROUND AND SET DOWN IMMEDIATELY ONCE COMPLETED.

1. Fold in the gate from the bow to the side of the tub.

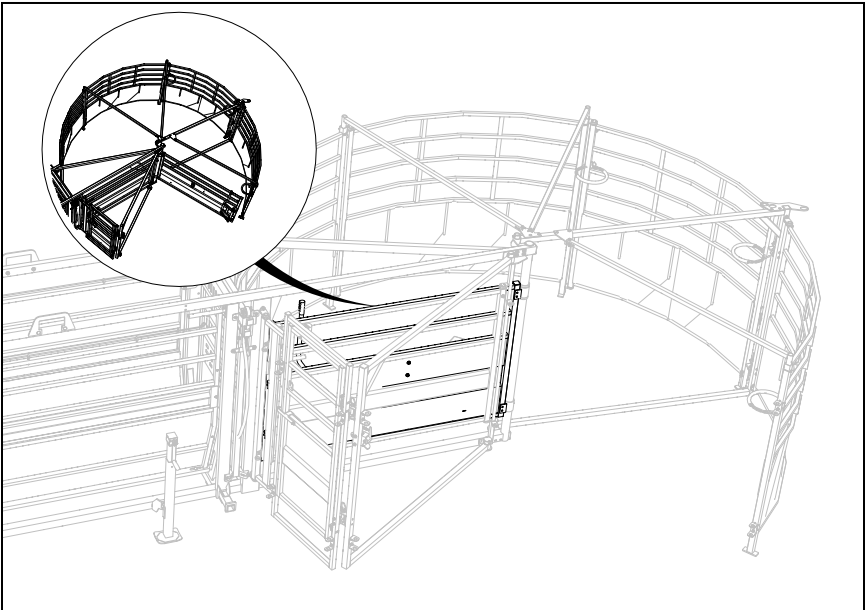

2. Remove pins.

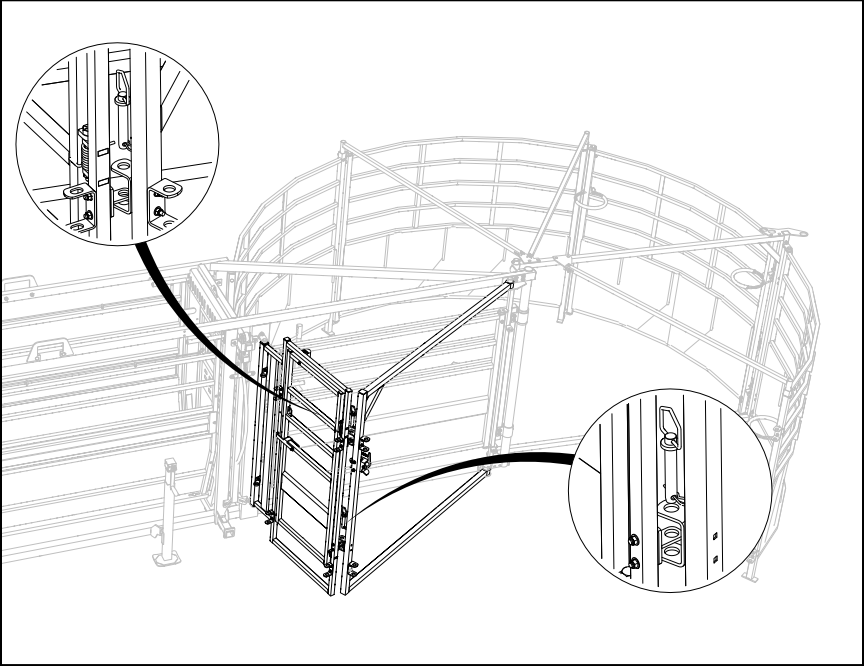

3. Fold in man-door.

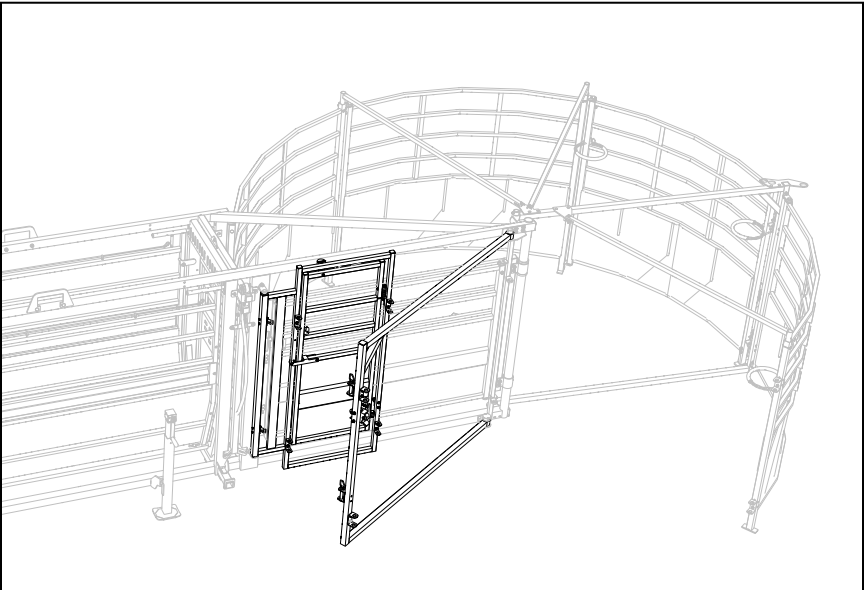

4. Fold in the bow and pin in place.

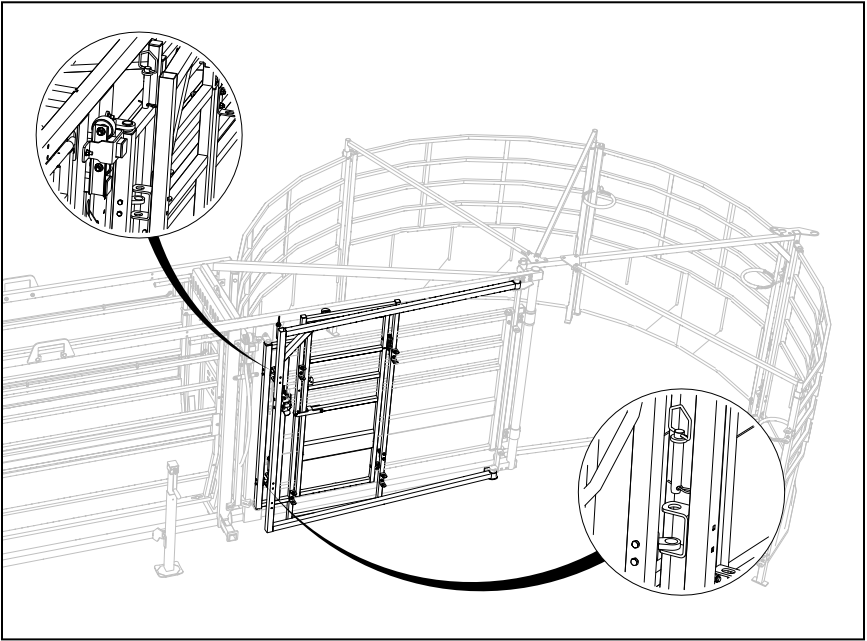

5. Unpin the tub panels from main bow.

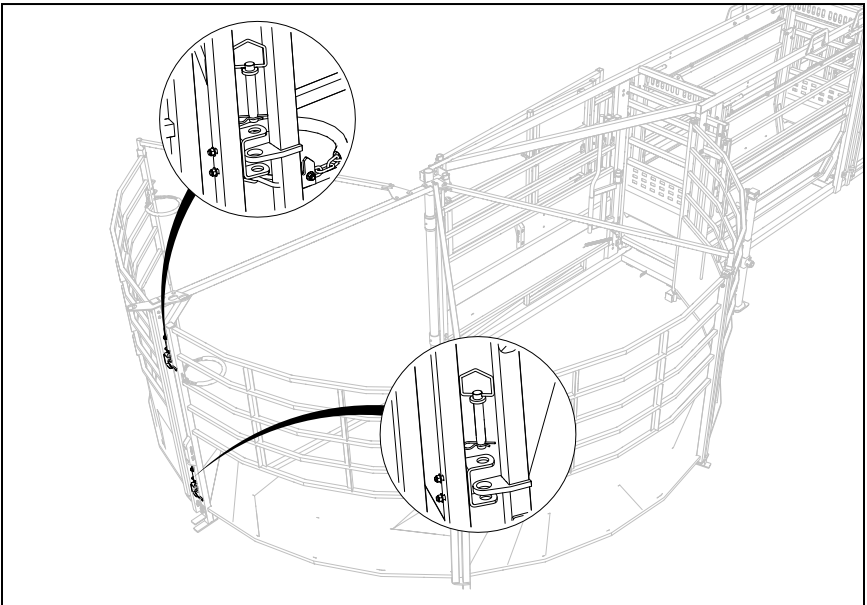

6. Detach joiner bars.

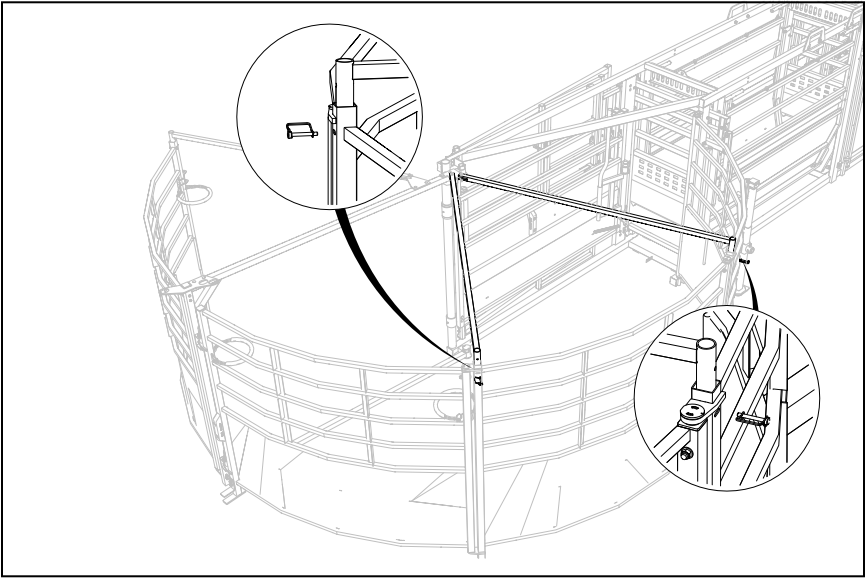

STOP YOU MUST PIN JOINER BARS IN PLACE

7. Put Joiner Bars back to their respective place.

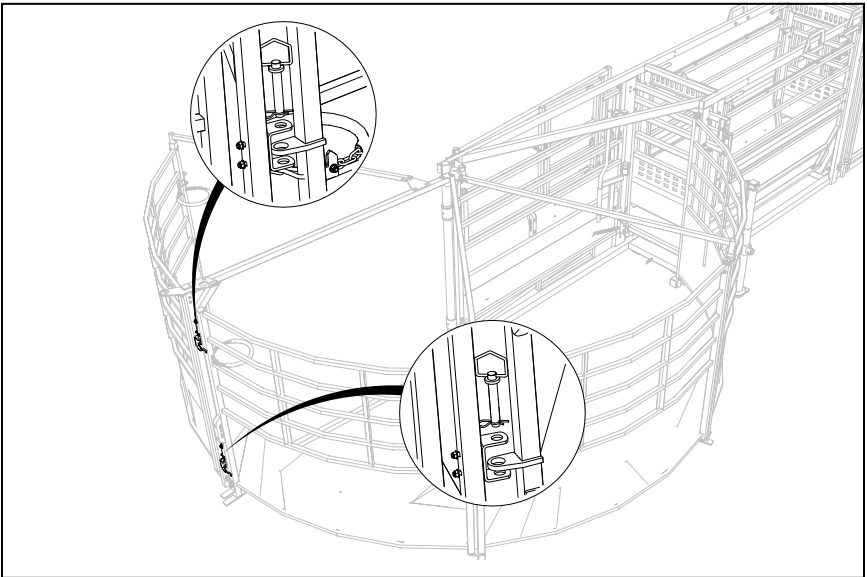

8. Fold in tub panels and chain up.

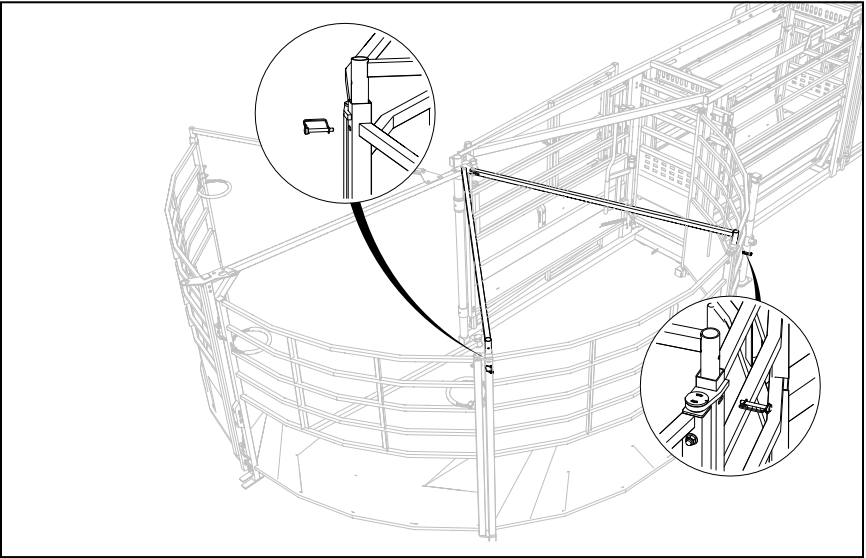

NOTE: If your unit does not have the budflow option, your tub is ready **FOR** transport. If you have the budflow option, please proceed with the following steps.

9. Fold in bow frame and BudFlow panel halfway.

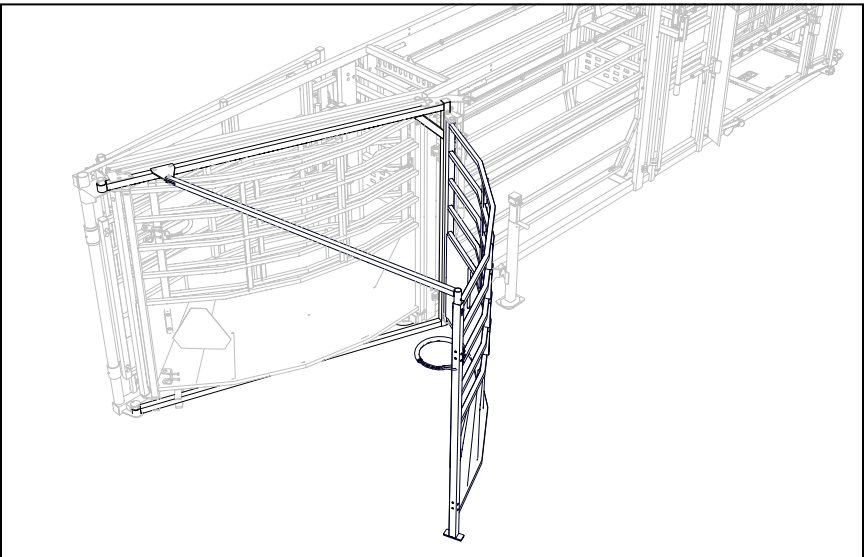

10. Remove joiner bar.

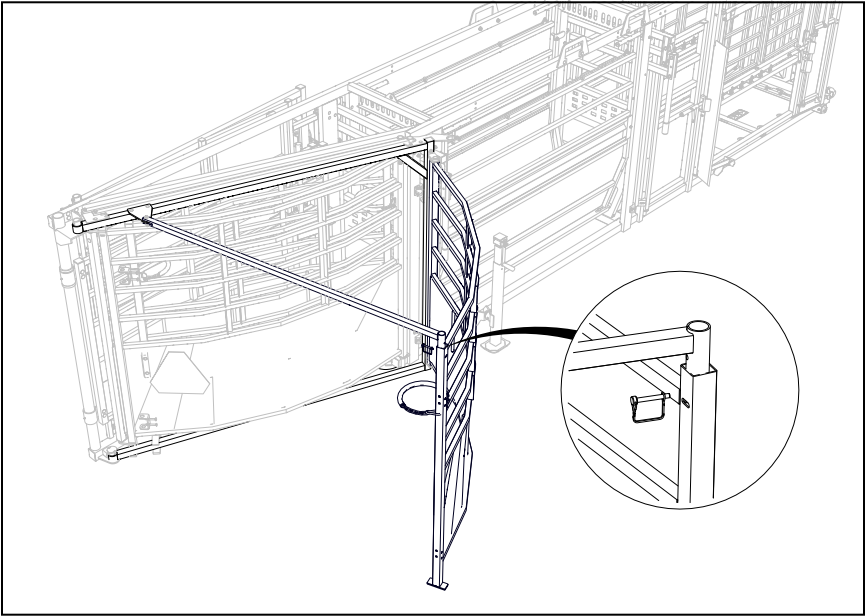

11. Attach joiner bar.

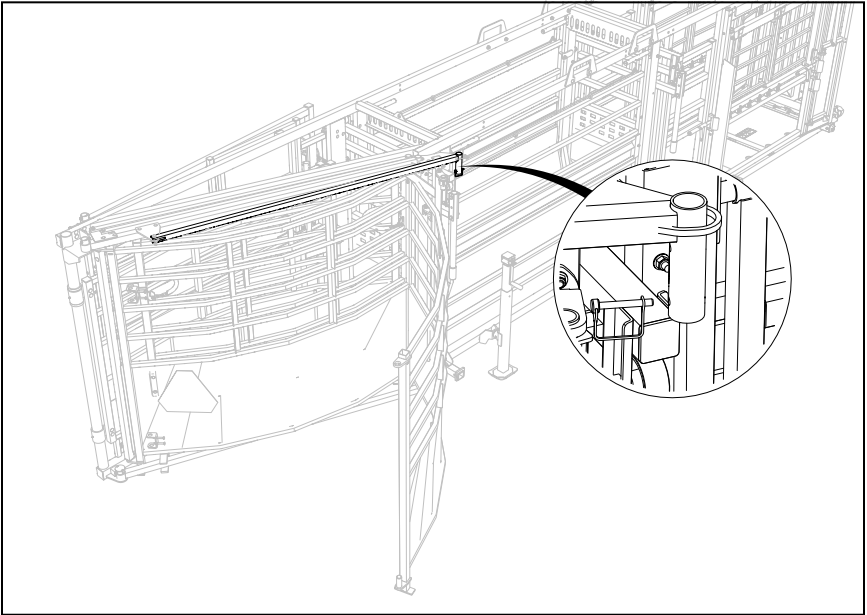

12. Fold in bow frame the rest of the way, chain in place and pin it up!

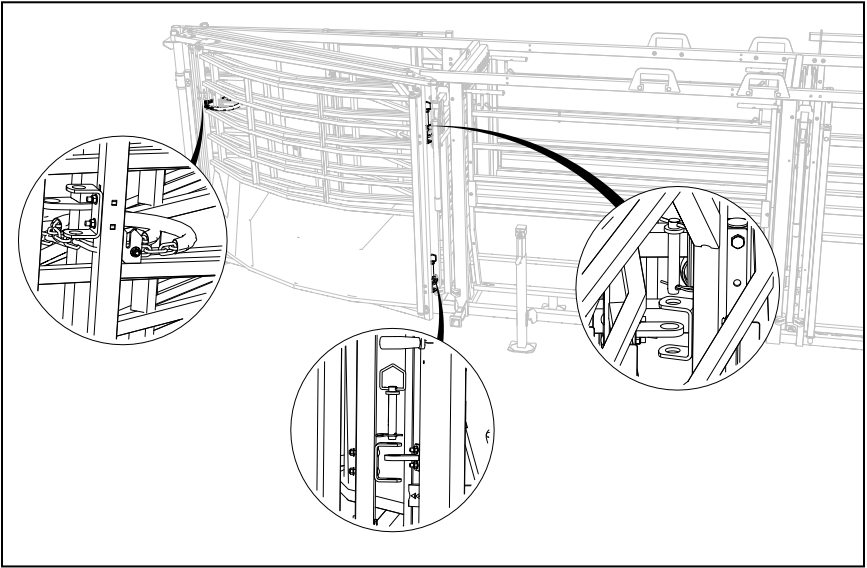

IMPORTANT: ENSURE THE BOTTOM BAR IS TUCKED INTO THE BLACK BRACKET!

13. Proceed to **INSTALLING TIRES**.

INSTALLING TIRES

1. Extend rear jacks to lift the unit off the ground until it is high enough to attach the tires. Using the **UP** button
2. Attach tires.

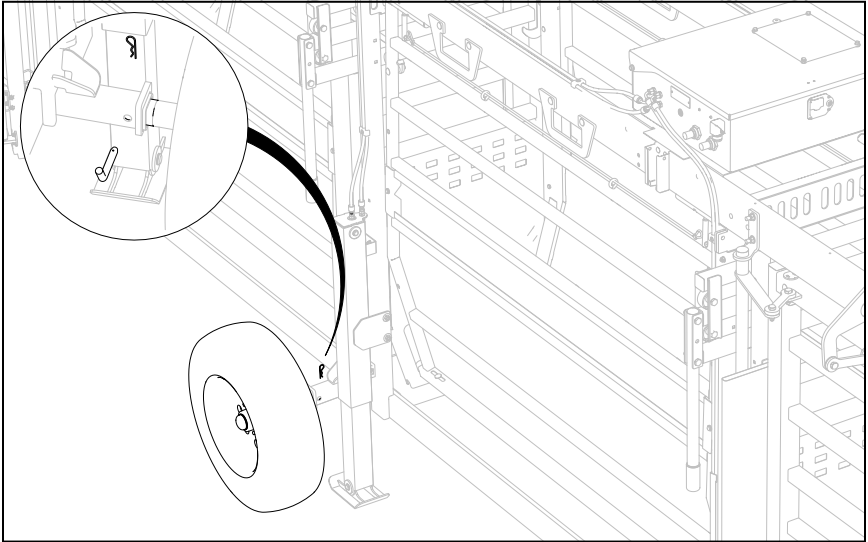

3. Retract rear jacks using **DOWN** button / rear jack handle until they stop.

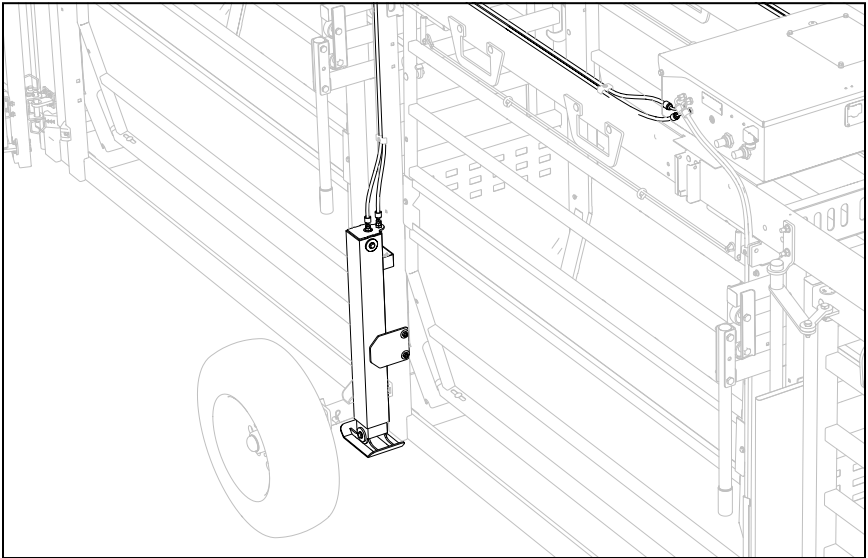



ENSURE THAT THE REAR JACK IS COMPLETELY RETRACTED BEFORE PROCEEDING.

4. Attach front jack.

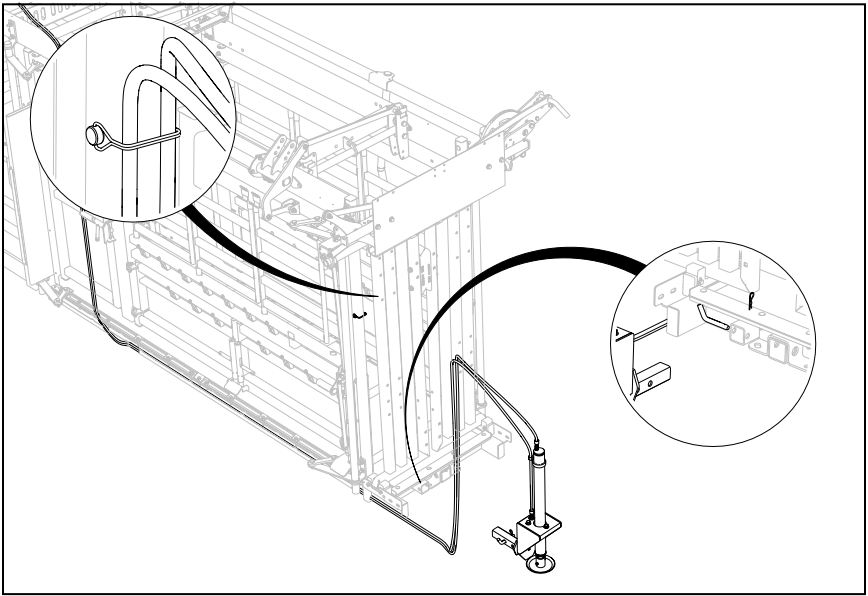

5. Extend front jack using **UP** button to lift chute.

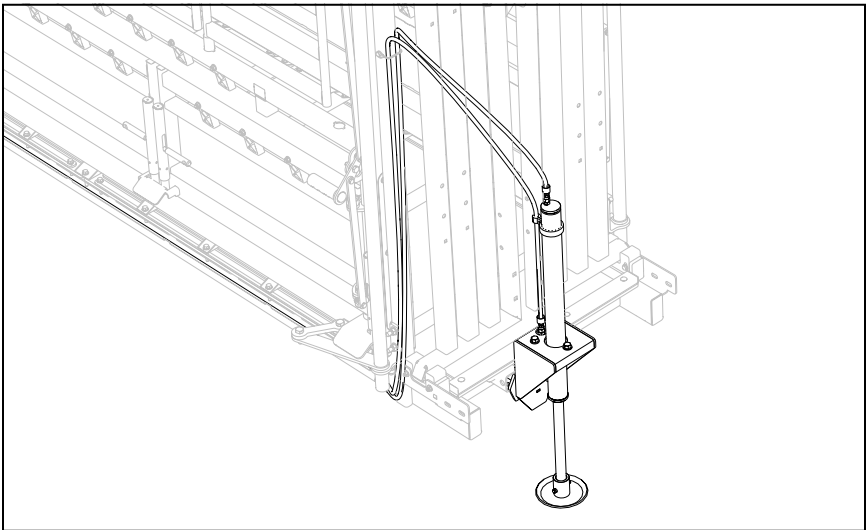

6. Install the hitch and secure with pin.

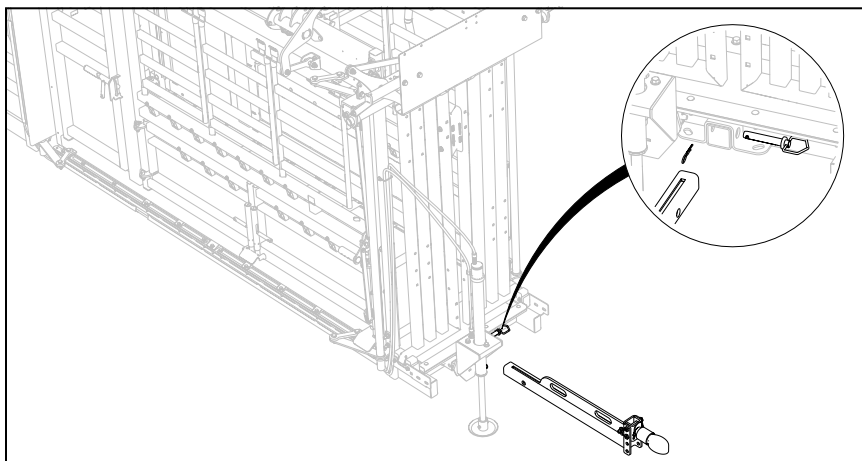

7. Attach the unit to the towing vehicle. Adjust the hitch to the proper position for the vehicle, if necessary.

8. Retract front jack using **DOWN** button until it stops.

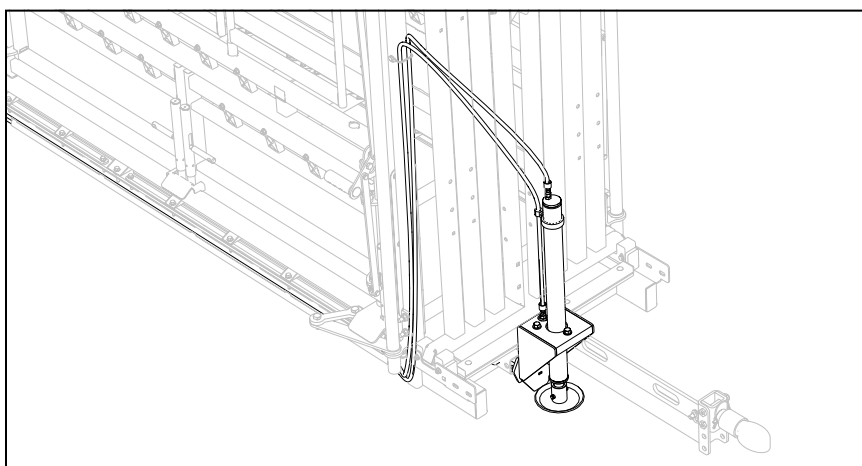

SAFETY CHECK:



- All doors and gates are latched.
- Jacks are retracted completely.
- Tires are in good condition.

READY FOR TRANSPORT

POWERLOCK 108 SERIES CATTLE CHUTE

THIS SECTION CONTAINS:

- Setting up the Powerlock 108 Series
- Operating the Powerlock 108 Series
- Power Failure
- Cold Start
- Powerlock 108 Series Add-Ons

Your chute will come fully assembled with the options you have ordered already fitted to the chute. However, it will be necessary to connect the hydraulic chute to a power source. The following guide will assist you in properly setting up your chute for use.

SETTING UP THE HYDRAULIC CATTLE SQUEEZE CHUTE

1. Hydraulics are plug and play. Please ensure that the color code of the hoses matches to the quick connects. Rule of thumb: red is pressure, yellow is tank.
2. When hooking up the hoses, ensure the couplers are engaged and the female sleeve is snapped into place.
3. Engage oil recirculation by pulling up on the valve knob to warm oil before use.
4. Start motor by following starting procedure.
5. When shutting down, engage oil recirculation again and shut gas engine off.

GAS POWER PACK



1	RECIRCULATION VALVE
2	QUICK CONNECT PORTS
3	OIL FILTER
4	OIL LEVEL SIGHT GLASS
5	BREATHER FILL CAP
6	ENGINE OIL PLUG
7	STARTER PULL CORD



WARNING:

DO NOT START GAS ENGINE WITHOUT CONNECTING PRESSURE AND TANK HOSES TO UNIT. DAMAGE MAY OCCUR IF RECIRCULATION VALVE IS NOT ENGAGED.

1. Open recirculation valve.
2. Open fuel shut off valve.
3. Ensure choke is fully engaged.
4. Pull starter handle to start engine.
5. Run engine on choke for 5-10 seconds.
6. Shut choke off completely.
7. Run engine with hydraulic oil recirculating for 5-10 minutes depending on ambient temperature.
8. Open recirculation valve and chute is ready to operate.

ELECTRIC POWER PACKS



WARNING:

DO NOT ATTEMPT TO CONNECT THE ELECTRIC POWER PACK IF YOU ARE NOT A CERTIFIED ELECTRICIAN. FOR YOUR SAFETY, ELECTRIC POWER PACKS MUST BE CONNECTED AND WIRED BY A FULLY CERTIFIED ELECTRICIAN.



1	RECIRCULATION VALVE
2	OIL FILTER
3	QUICK CONNECT PORTS
4	BREATHER FILL CAP

OPERATING THE POWERLOCK CATTLE CHUTE



ENSURE ALL CHUTE FUNCTIONS AND ADD-ONS ARE WORKING PROPERLY BEFORE OPERATING.

1. Ensure the head gate, tail gate, and all access points are closed before the animal enters the chute.
2. Open tail gate for the animal to enter the squeeze chute enclosure.
3. Close tail gate.
4. Open head gate slightly more than the neck size of the animal to tempt the animal to stick its head through the head gate. When neck of animal is in the correct position, quickly close the head gate securely on the animal's neck.
5. If required, side squeeze animal and engage head restraint to restrain further movement.
6. If the animal applies excessive pulling pressure on head gate, it is recommended to use the anti-backing bar behind cattle rump.



CONFIRM ANIMAL IS SECURELY HELD BEFORE CARRYING OUT ANY HUSBANDRY WORK.

COLD START

To cold start the unit it when it is not at operating temperature, follow the below instructions.

1. With recirculation valve locked in the up position, the cold start allows the oil to circulate within the power pack to warm the oil, allowing for faster flow rate to the chute.
2. With recirculation valve locked in the down position, it is engaged to run the chute.

POWER FAILURE

If you should experience a loss of power while you have an animal in the chute, please follow the instructions below:

1. Operate the hydraulic levers to allow fluid to flow out of the cylinders and release the pressure on the animal.
2. Check to make sure that the animal is free of any injury.

POWERLOCK 108 SERIES ADD-ONS

4TH GEN HEAD HOLDER

For complete information, read the Head Restraint manual.

REQUIREMENTS:

- 2 people
- 9/16" Wrench
- 3/4" Wrench

INSTALLATION:

1. Install top and bottom stops to the slots in the Head Gate

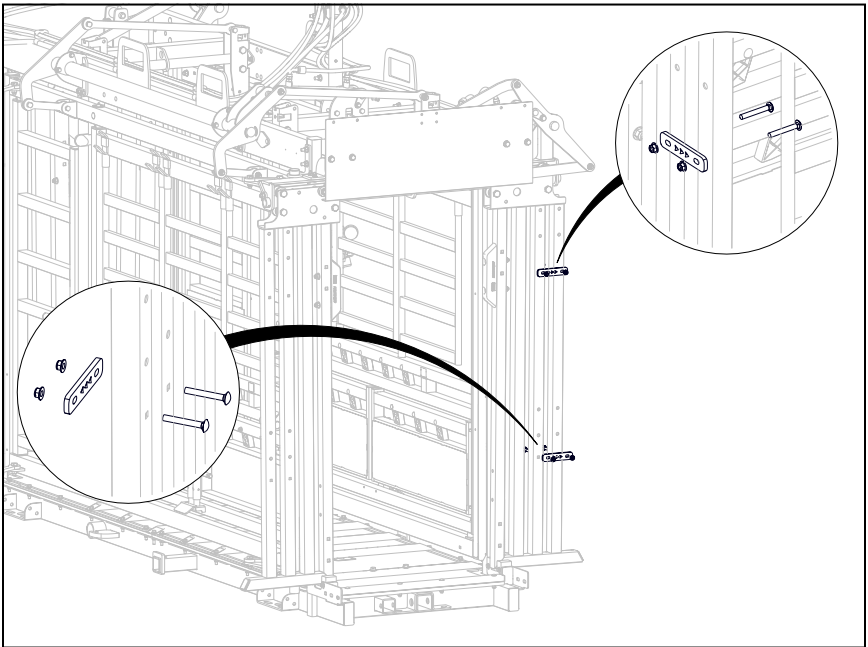

2. Align the rear Head Holder tube between the Head Gate rails, resting the Head Holder on the stop.

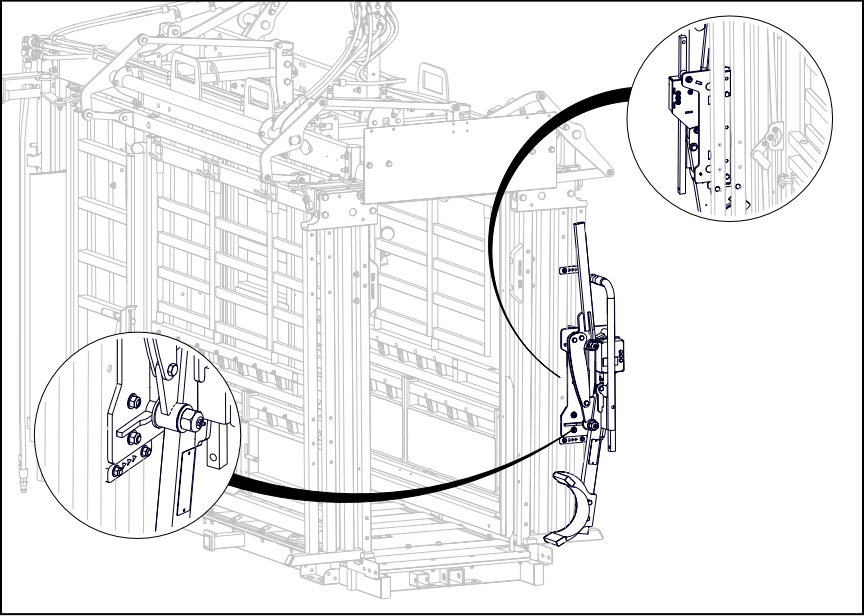

3. Loosely fasten on rear brackets.

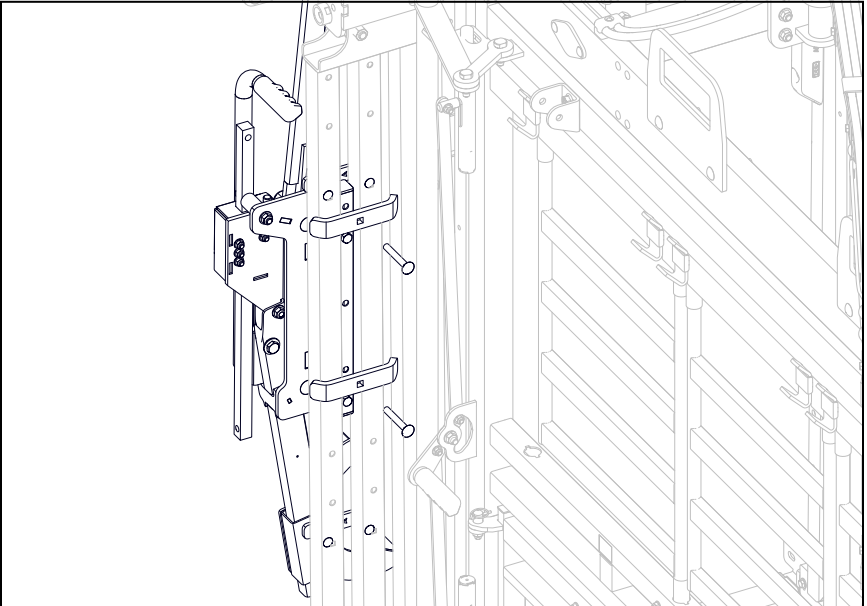

4. Lift the Head Holder to desired position and tighten brackets.

SAFETY PRECAUTIONS:

- Ensure the Head Holder remains open until required to hold the animal's head.

MAINTENANCE:

1. Add grease throughout grease nipples as needed.
2. Every 6 months:
 - a. Check bolts to ensure they are tightened properly.
 - b. Spray brake cleaner on a rag and wipe the lock box shaft while opening and closing the Head Holder.

LUG POSTS

REQUIREMENTS:

- 2 people
- 9/16" wrench
- 2 x 3/4" wrench

INSTALLATION:

NOTE: Only install one side at a time so name shield stays on the chute

1. Loosen bolts holding decal name shield.

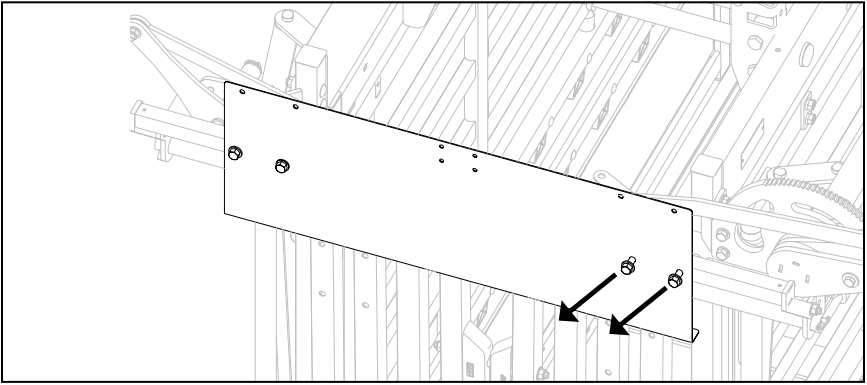

2. Slide Lug Post behind the bolt heads. Do not tighten.

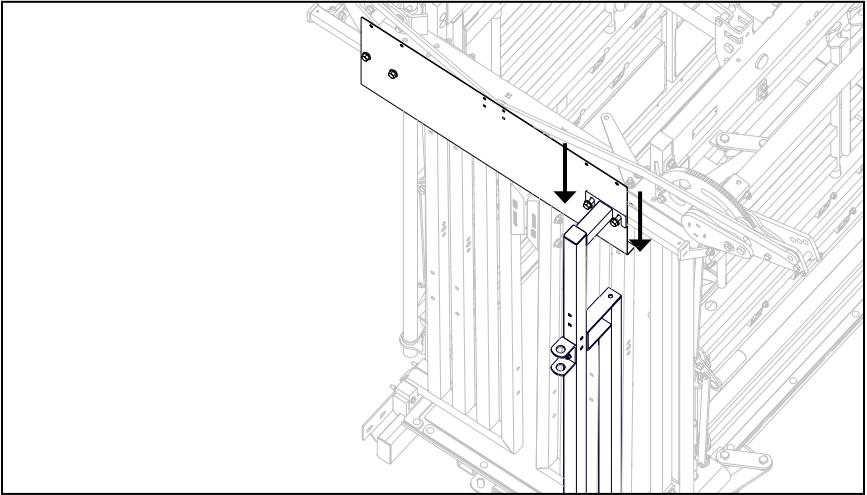

3. Align bottom of lug post and carriage head bolts with the head towards the inside of the chute.

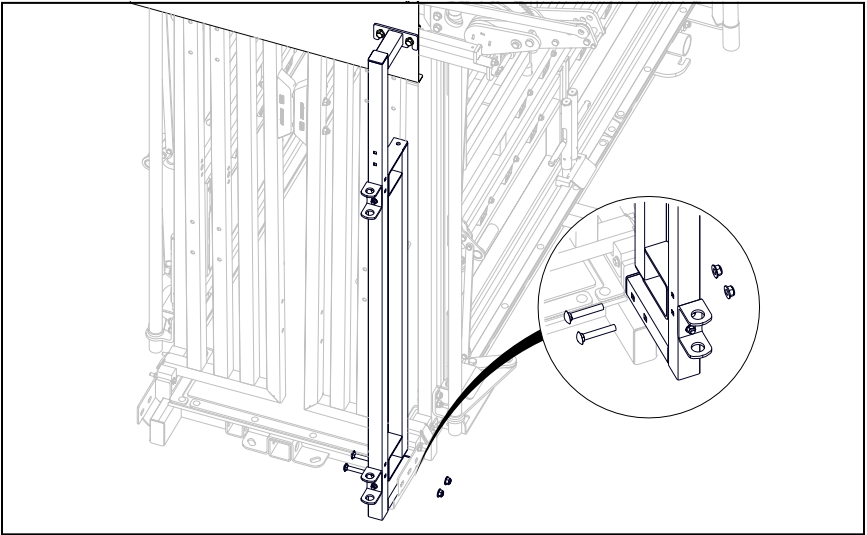

4. Tighten down all 4 bolts.

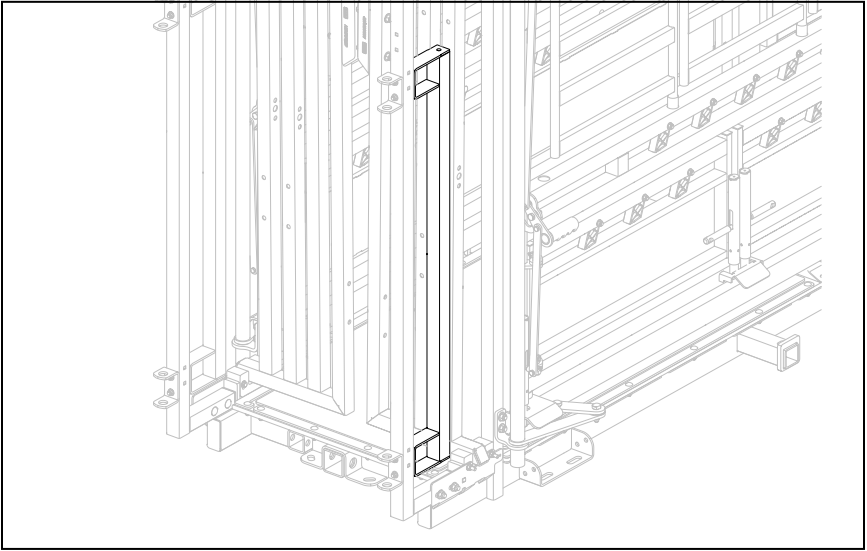

5. Repeat steps to install the post on the opposite side.

NOTE: Remove filler post before installing head holder.

2. Attach panel clips to the side of Lug Posts.

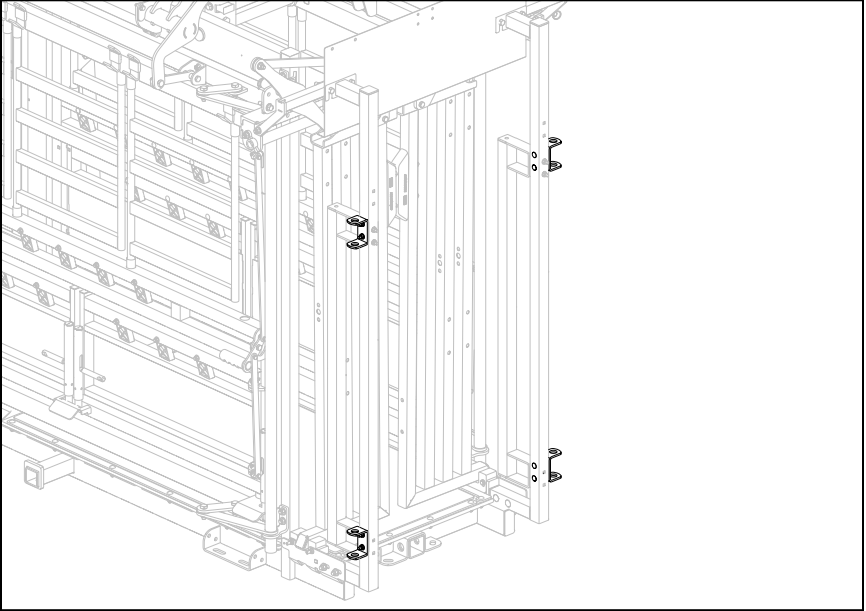

3. Bolt on striker plate to the bottom of Lug Posts on working side.

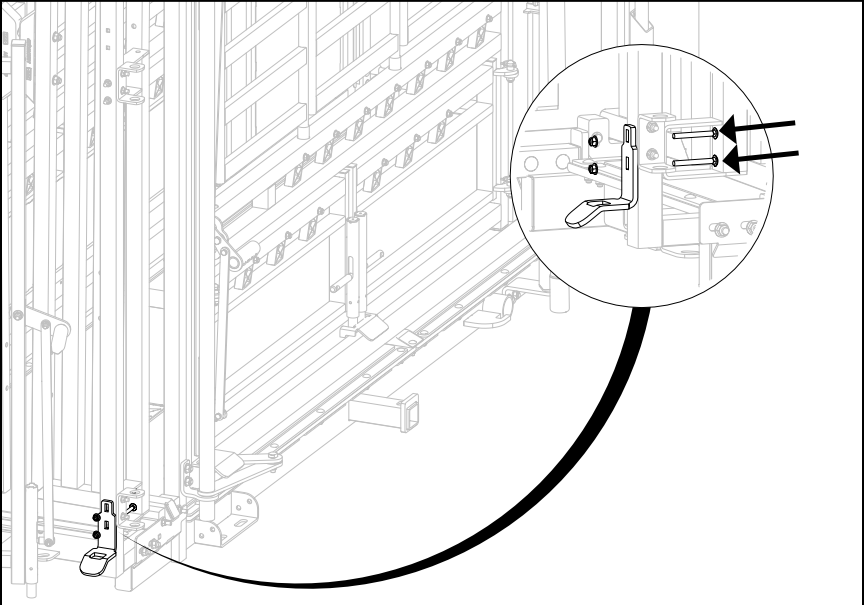

4. Mount Balk gate and hinges to the front of offside Lug Post.

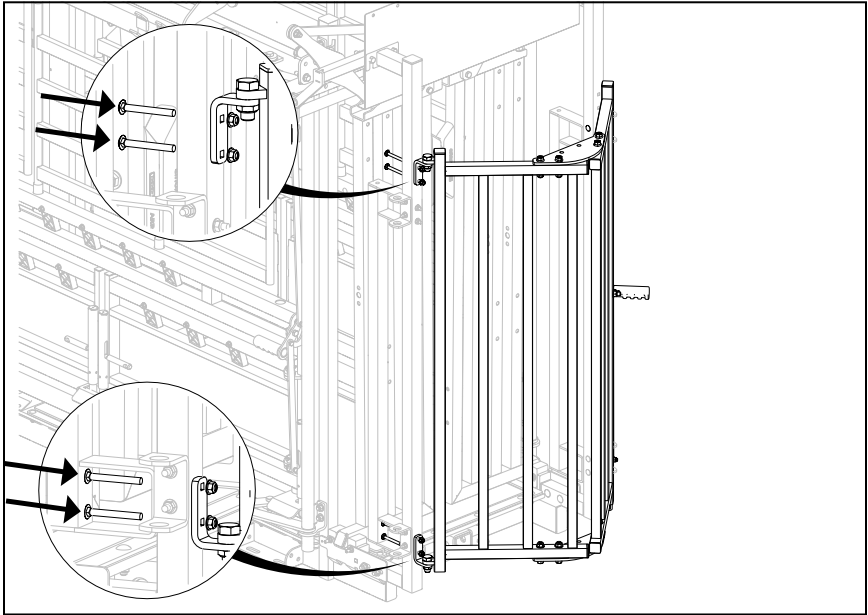

SHEETED STERNUM BAR

REQUIREMENTS:

- 2 People
- 3/4" wrench
- 1 1/8" wrench

INSTALLATION:

1. Remove stock bolts from hold down.

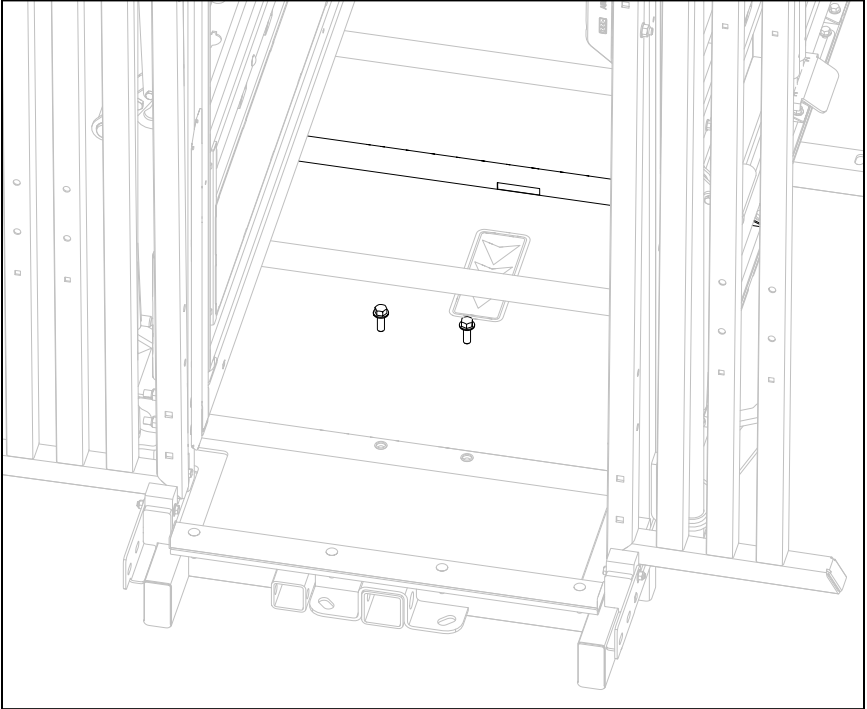

2. Insert back end of Sternum Bar into hold down.

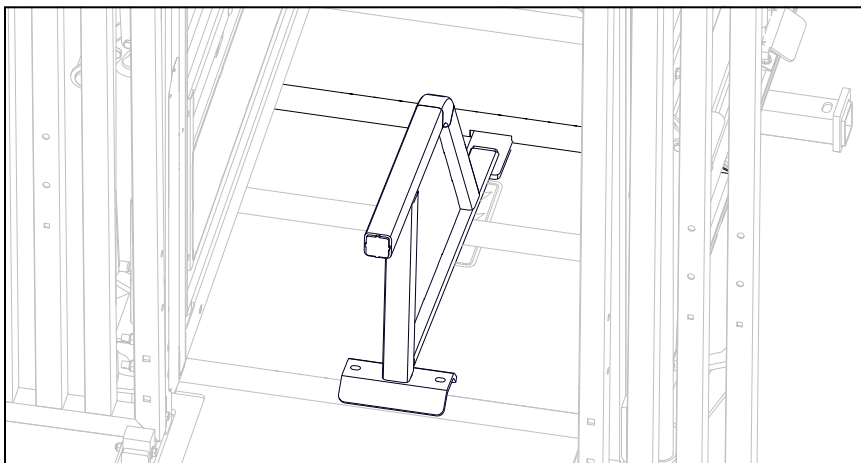

3. Bolt down the front of the Sternum Bar.

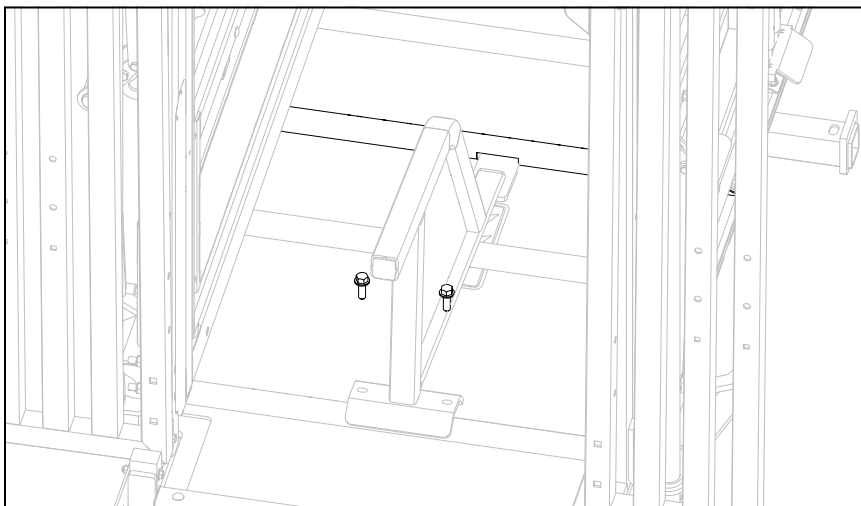

SAFETY CHECK:

- Ensure the Sternum Bar is installed correctly before running cattle through the chute.

SAFETY PRECAUTIONS:

- It is recommended you remove the sternum bar when working calves.

CALF RESTRAINER BAR

REQUIREMENTS:

- 2 People
- 3/4" wrench
- 1 1/8" wrench

INSTALLATION:

1. Open emergency doors.

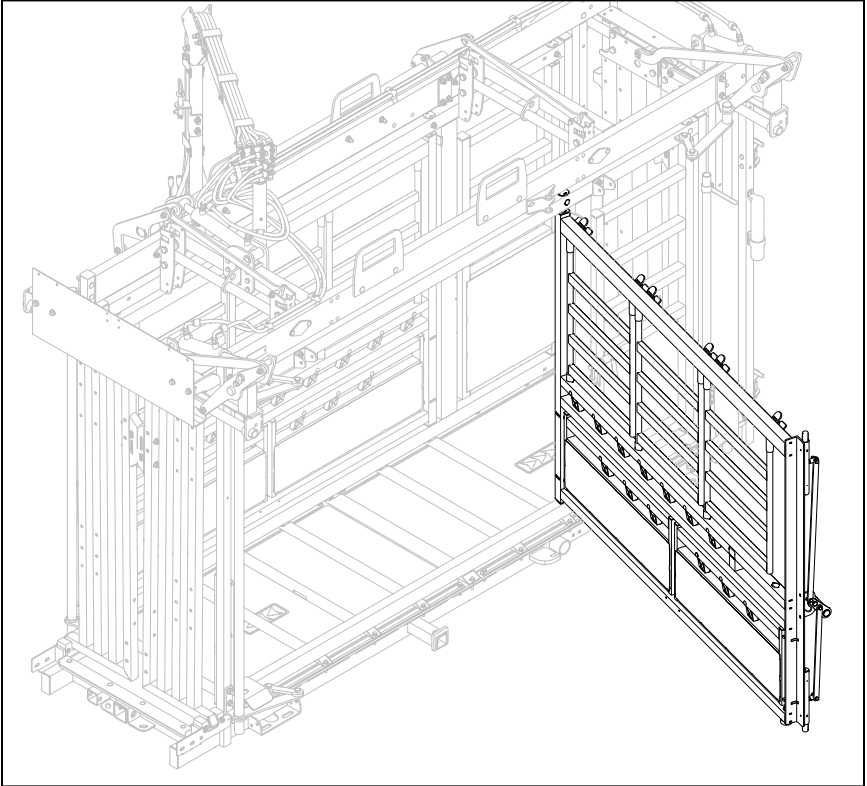

2. Insert Restrainer bar so that top and bottom brackets are resting on squeeze frame tubes.

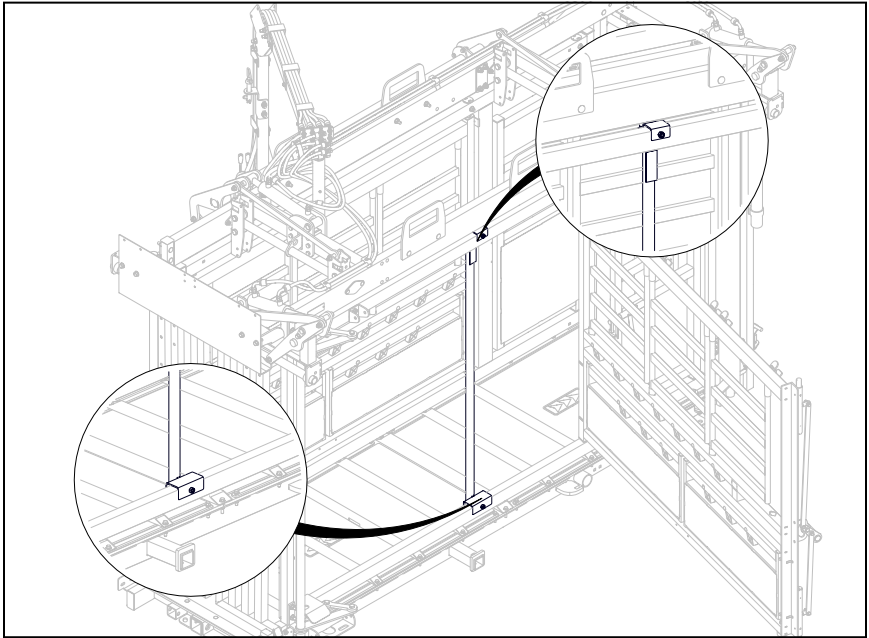

3. Adjust the Bar to desired position and tighten knobs.

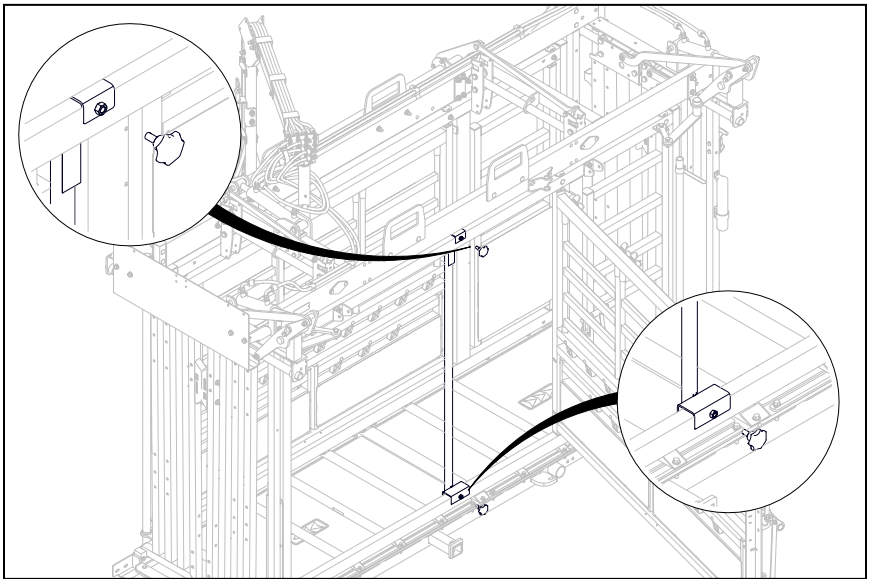

HYDRAULIC HEAD SWEEP

Your Powerlock 108 Series will come with the hydraulic head sweep installed. If you are having trouble with your hydraulic head sweep, contact Client Care at 1-877-275-6075.

HYDRAULIC NECK EXTENDERS

Your Powerlock 108 Series will come with hydraulic neck extenders installed. If you are having trouble with your hydraulic neck extenders, contact Client Care at 1-877-275-6075.

HYDRAULIC NECK EXTENDERS

INSTALLATION:

1. If your chute comes with hydraulic neck extenders installed, it is ready for use.
2. If your chute does not come equipped with hydraulic neck extenders, please contact our Client Care team to order.



IF YOU NECK EXTENDERS BEGIN TO OPERATE OUT OF SYNC, FULLY RETRACT THEM AGAINST THE HEAD GATE, AND HOLD UNTIL BOTH SIDES ARE FLAT AGAINST THE HEAD GATE.

SAFETY PRECAUTIONS:

1. Ensure that the hydraulic neck extenders are operating correctly before running cattle through the chute.

EASY FLOW ALLEY SECTION

THIS SECTION CONTAINS:

- Adjusting the Easy Flow Alley
- Using the Removable Panels
- Using the Emergency Exit
- Scale Platform Installation
- Rolling Door Switch

ADJUSTING THE EASY FLOW ALLEY



ACTIVATE THE SAFETY LATCHES BEFORE ADJUSTING.

Safety latches must be in place when adjusting the width of the alley. Failure to use the safety latches may cause the panels to drop unintentionally, resulting in damage to persons or property.

1. Pull the adjustment cable between the slam latches to release the panel.
2. Adjust the panel to the desired position.
3. Lock the panel into position with slam latches.



BOTH LATCHES SHOULD BE SECURELY FASTENED IN THE PARALLEL ADJUSTMENT SLOTS BEFORE PROCEEDING.

4. Repeat **STEPS 1 TO 3** to adjust the opposite side.

USING THE REMOVABLE SIDE PANELS

The removable side panels can be configured in multiple positions, allowing you to control what cattle see in the alleyway. Additional panels can be added, as desired.

1. Unscrew bolts on both ends to release the panel.

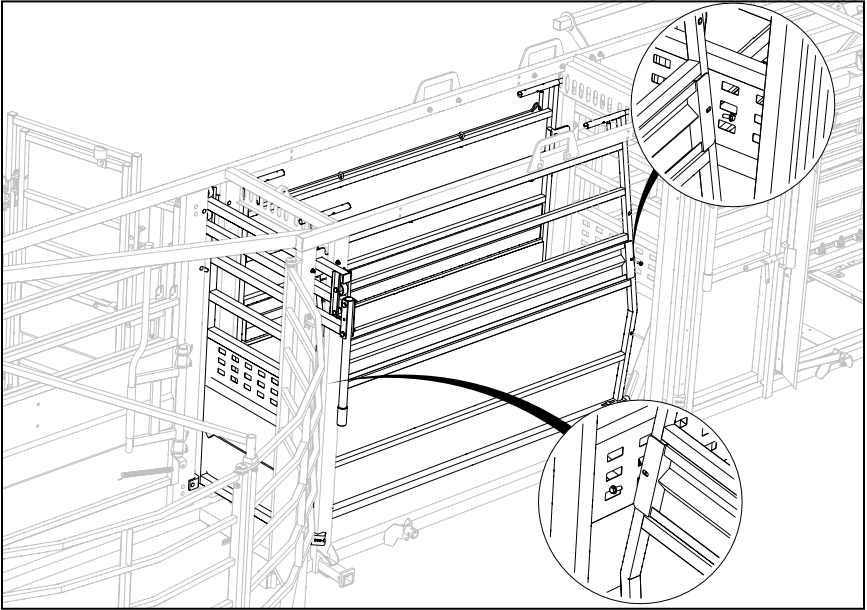

2. Remove the panel and install in the desired position.

If you do not require high sheeting, or are working with calves, panels can be stored on the side of the alley.

USING THE EMERGENCY EXIT

In the event of a downed animal or other emergency, you can use the emergency exit to release livestock from the alleyway. Exercise caution when releasing livestock, as they may act in unpredictable and/or uncharacteristic ways while distressed.

A video explaining how to safely lower the Easy Flow Alley Emergency Exit can be found here: youtu.be/4eVA-R1v1bo or scan the QR code below.



REQUIREMENTS

- 2 people



DANGER:

PANELS ARE VERY HEAVY AND WILL DROP WITH EXCESSIVE PRESSURE WHEN AN ANIMAL IS CONTAINED IN THE ALLEY. FAILURE TO OPERATE THE EMERGENCY EXIT PROPERLY MAY RESULT IN DAMAGE OR INJURY.

INSTRUCTIONS

1. Ensure all persons and property are out of the way.
2. Tie a minimum 17' long rope on the top bar of the panel.
3. Wrap the rope around the center post on the alley twice.
4. Deactivate the safety latch on the chosen exit side.



TRANSFER TO THE OPPOSITE SIDE OF THE ALLEY BEFORE PROCEEDING (NON-EXIT SIDE).

1. Release the slam latches on the panel to be lowered.
2. Lower the exit panel to the ground slowly with the rope.
3. Assist the animal to exit the alley and provide care, as necessary.
4. Once the animal is free of the alley, lift the panel back into position and secure the slam latches.
5. Ensure both latches are securely fastened in parallel adjustment slots.



ACTIVATE THE SAFETY LATCH BEFORE PROCEEDING.

6. Remove the rope. It is now safe to continue running cattle through the alley.

SCALE PLATFORM INSTALLATION

REQUIREMENTS:

- 2 people

INSTALLATION:

1. Adjust the alley width to the narrowest setting.

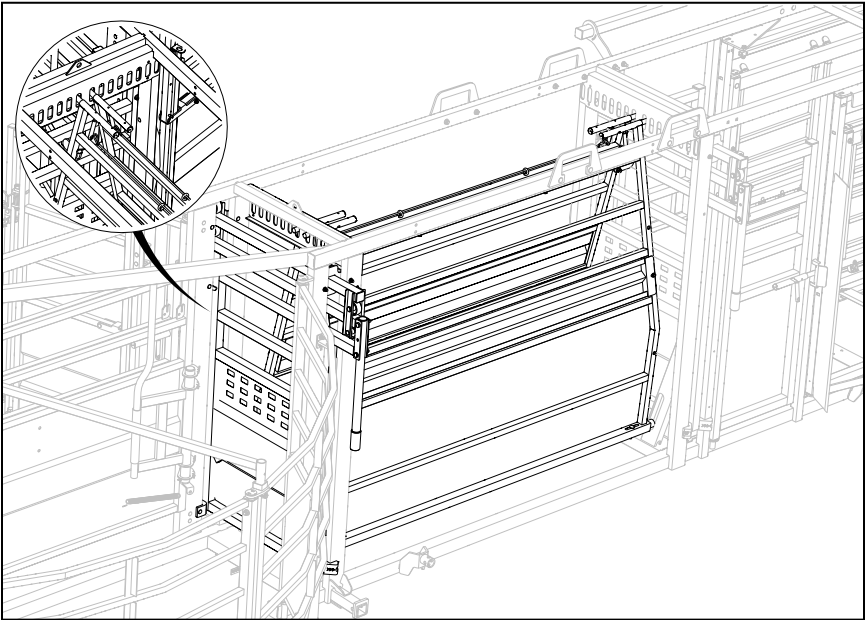

2. Lift the side panel and set the latch above the alley bow. Repeat step for the opposite side panel.

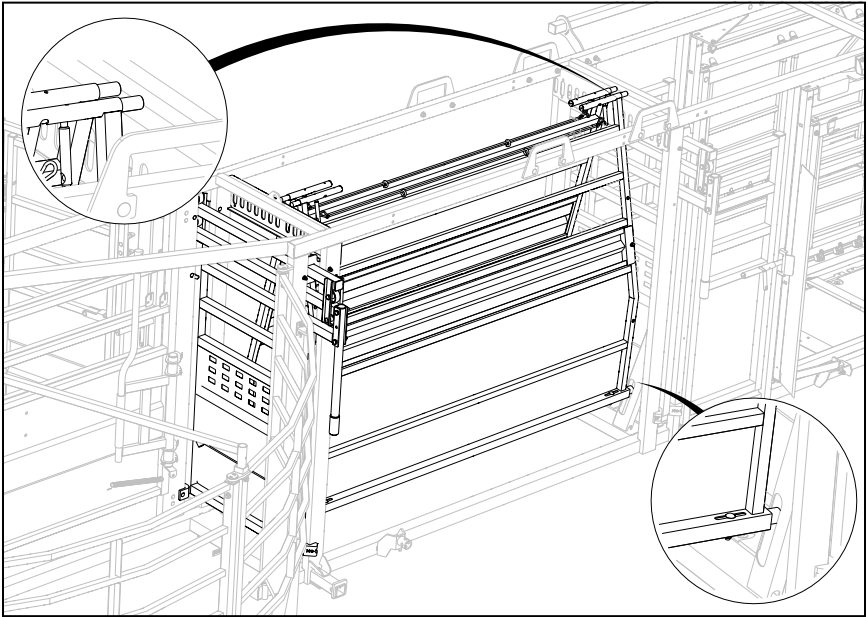

WARNING:

THE PANELS ARE VERY HEAVY. YOU WILL NEED AT LEAST 2 PEOPLE TO LIFT EACH PANEL.

3. Slide Scale Platform underneath.

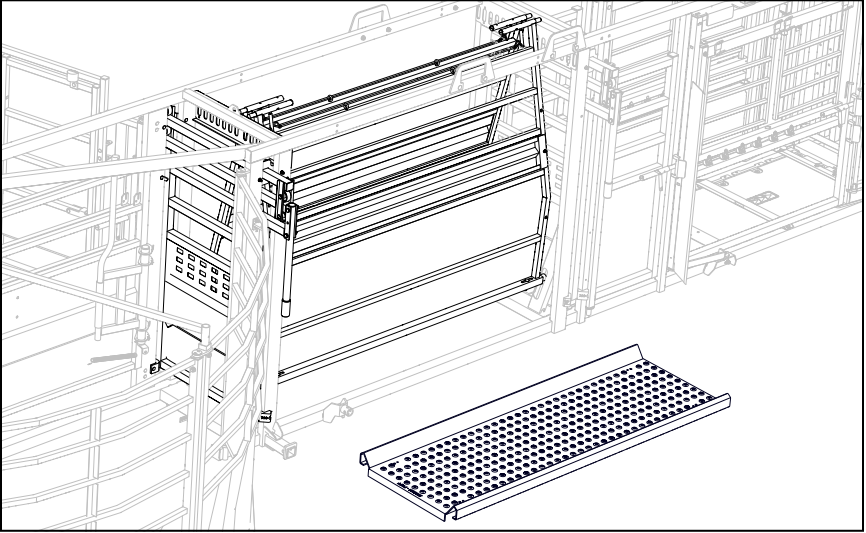

4. Lower the side panels back to working position.

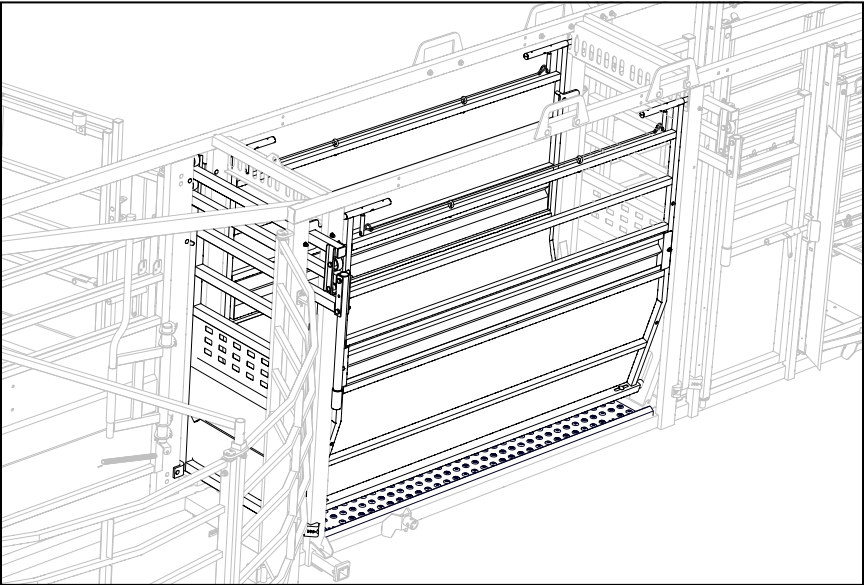

SAFETY PRECAUTIONS:

1. Please ensure that the scale platform is installed correctly, and side panels are properly latched before running cattle through the unit.

ROLLING DOOR CONVERSION

REQUIREMENTS:

- 1 person
- 9/16" wrench
- 2 x 3/4" wrench

INSTALLATION:

1. Open Rolling Door and remove top and bottom wheel from working side.

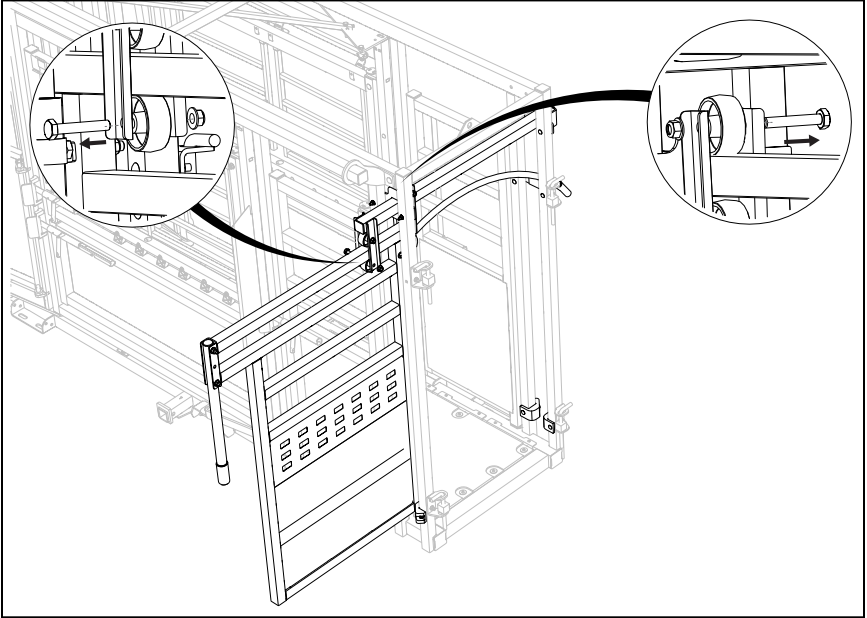

CAUTION:

DOOR WILL SWING DOWN.

2. Remove the Rolling Door completely.

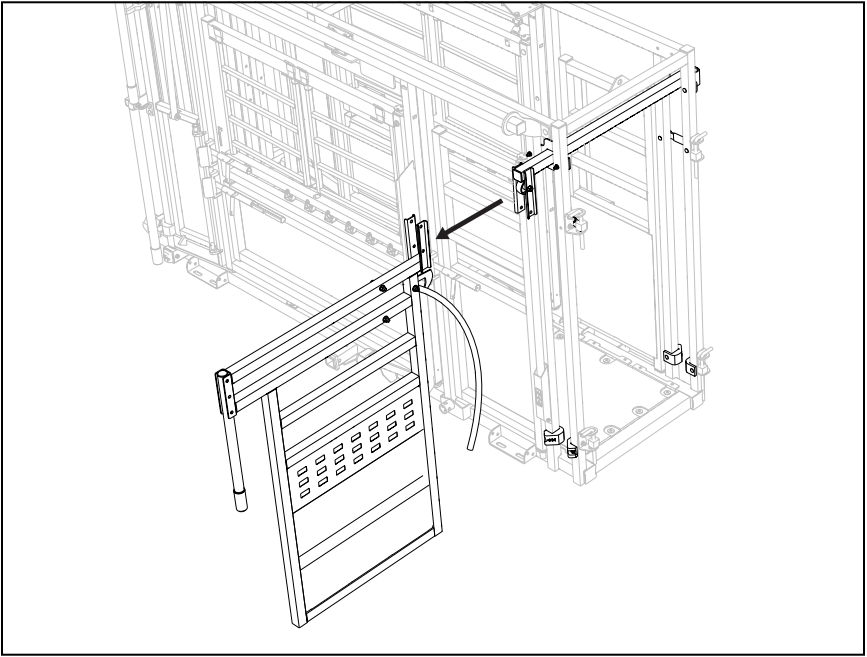

3. Remove the side bracket, track plate, and door handle slider as shown.

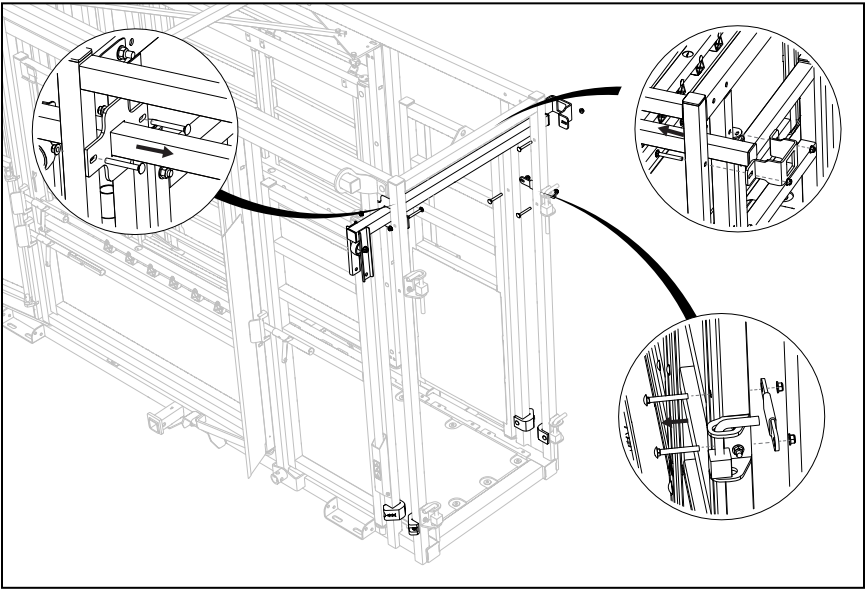

4. Install the side bracket, track plate, and door handle slider on opposite side.

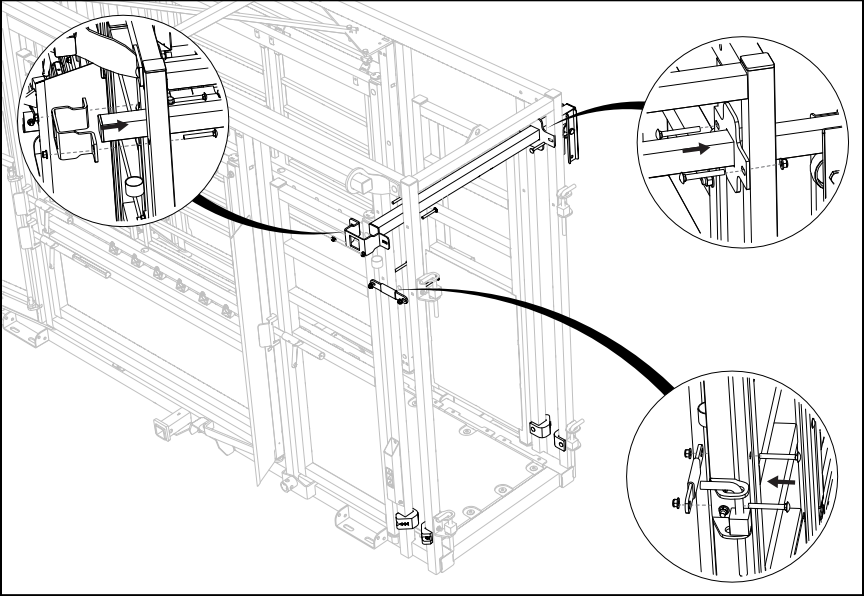

5. Slide the door into the track and install top and bottom wheels.

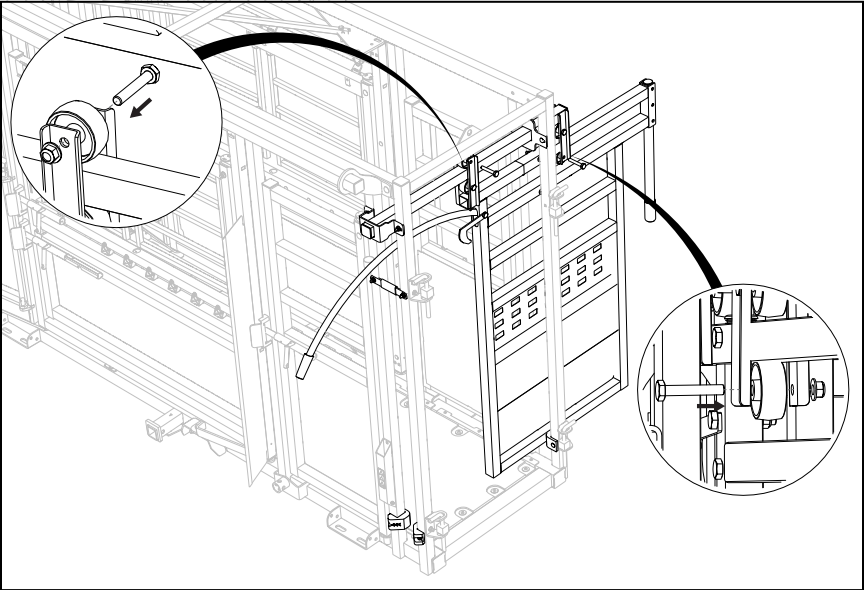

6. Close door.

COLLAPSIBLE TUB

THIS SECTION CONTAINS:

- 3E BudFlow Installation
- Operating Guidelines
- Using the 3E BudFlow Tub



3E BUDFLOW INSTALLATION

REQUIREMENTS:

- 2 People
- Loader with 2000lb capacity
- Side cutters or knife
- Wrench/Socket:
 - 2 x 9/16"
 - 2 x 3/4"
 - 2 x 1-1/8"

USER ASSEMBLY PARTS LIST

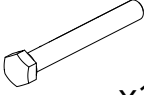
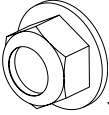
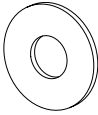
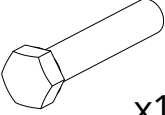
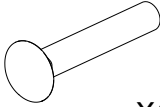
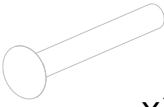
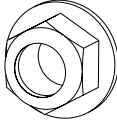
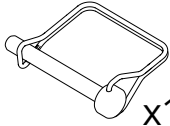
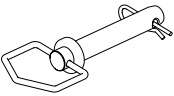
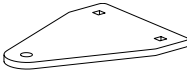
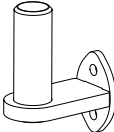
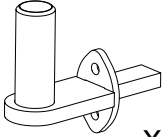
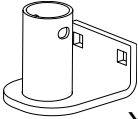
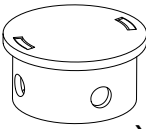
The parts list below lists only components of the BudFlow kit that will need to be removed and installed during assembly.

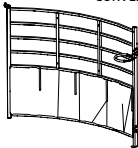
7003203 BOLT-HH-0.375-16-3-Z5  x11	7003178 NUT-FNYL-0.375-16-Z5  x11	7002300 WASHER-0.406-1.000-0.056-ZPS  x10	7002285 BOLT-HH-0.5-13-2.5-Z5  x1
7002295 BOLT-CAR-0.5-13-3-Z5  x4	7002766 BOLT-CAR-0.5-13-4-Z2-FT  x2	7003177 NUT-FNYL-0.5-13-Z5  x7	7002103 WIRE LOCK PIN Z 5/16-3"  x1
7002108 SWIVEL PIN Z 7/8 X 4 1/4"  x2	2025217 75/88 BUDTUB JOINER BAR MOUNT PLATE  x1	2025246 BOLT ON HINGE NO TAB  x1	2002503 BOLT ON GATE HINGE  x1
2024675 88 TUB 3E BOW BTM PVT  x1	2026537 75/88 TUB PIVOT CAP  x1	2023310 3E DOOR  x1	2024753 TUB BUD FLOW CURVED PANEL  x1
9000542 75/88 TUB JOINER BAR x1	9000990 88 TUB 3E BOW x1		

LEFT HAND INSTALLATION:

NOTE: Instructions are shown on 8818 but the steps will be the same on other compatible portables.

1. Move BudFlow bundle close to the portable that it is being added too. Ensure to pick the bundle from the rail and side shown.

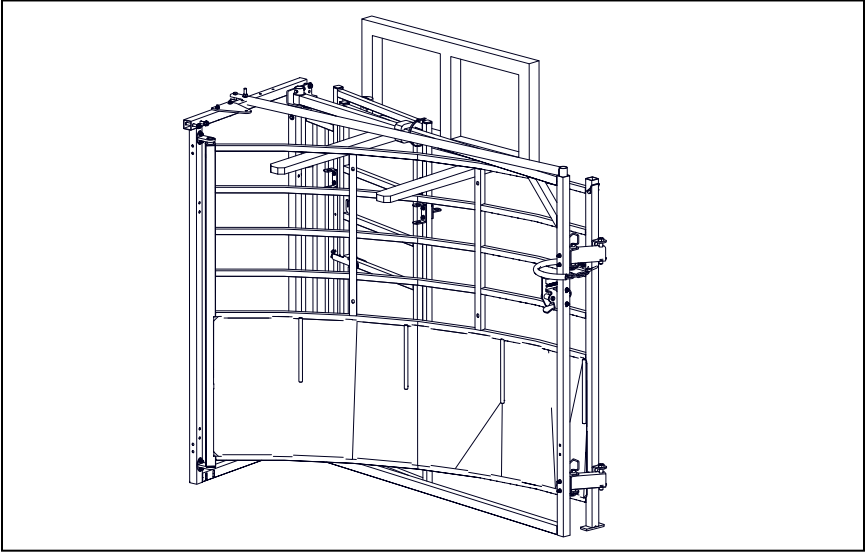

2. Unfold the collapsible tub according to instructions earlier in the product manual.

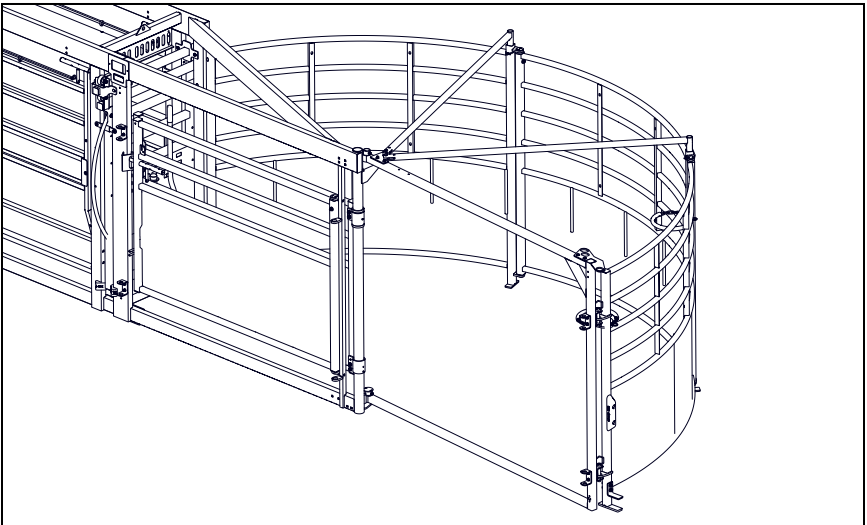

3. Remove panel clips, 3/8" x 3" carriage head bolts and nuts from frame. Set them aside.

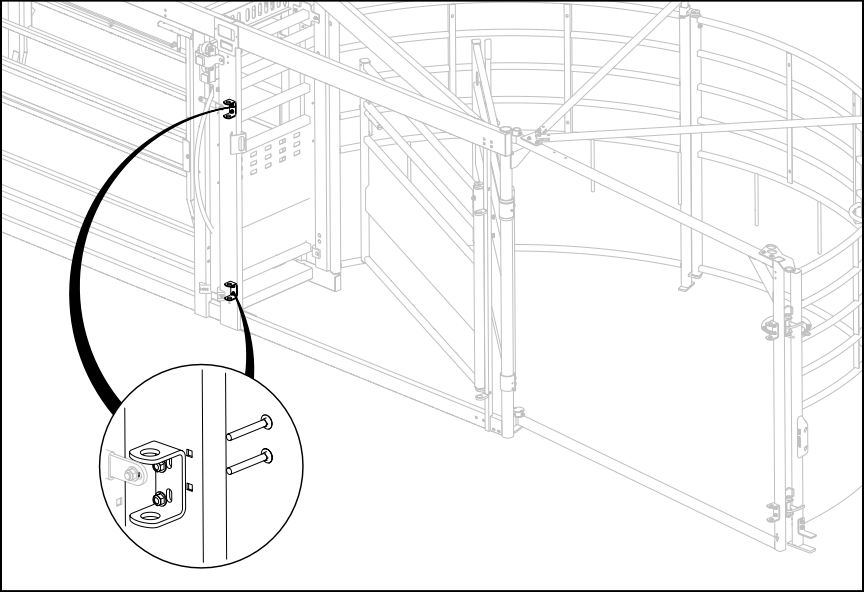

4. Install panel clips removed in the previous step onto the bow where shown. Leftover hardware from previous step can be discarded.

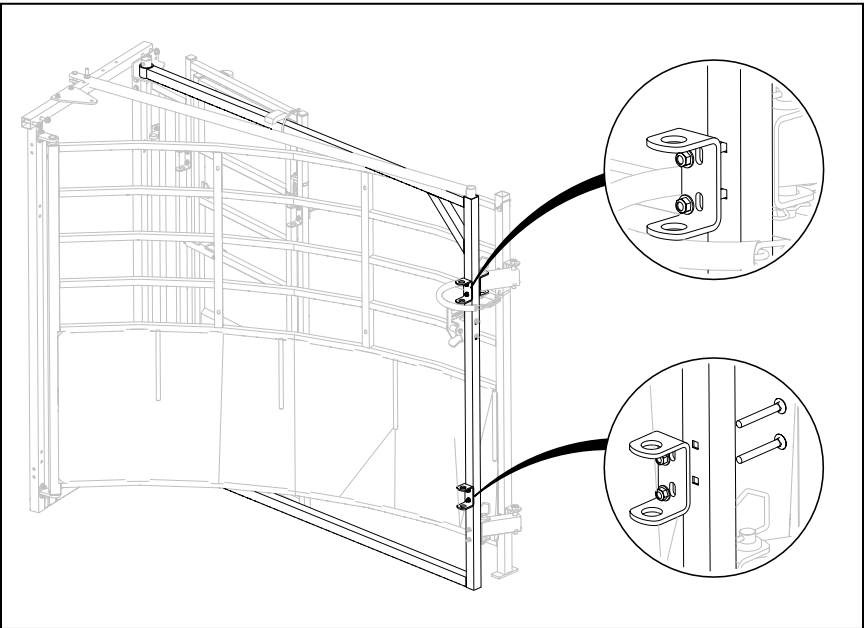

5. Remove panel clips from bow and re-fasten hardware. Set aside.

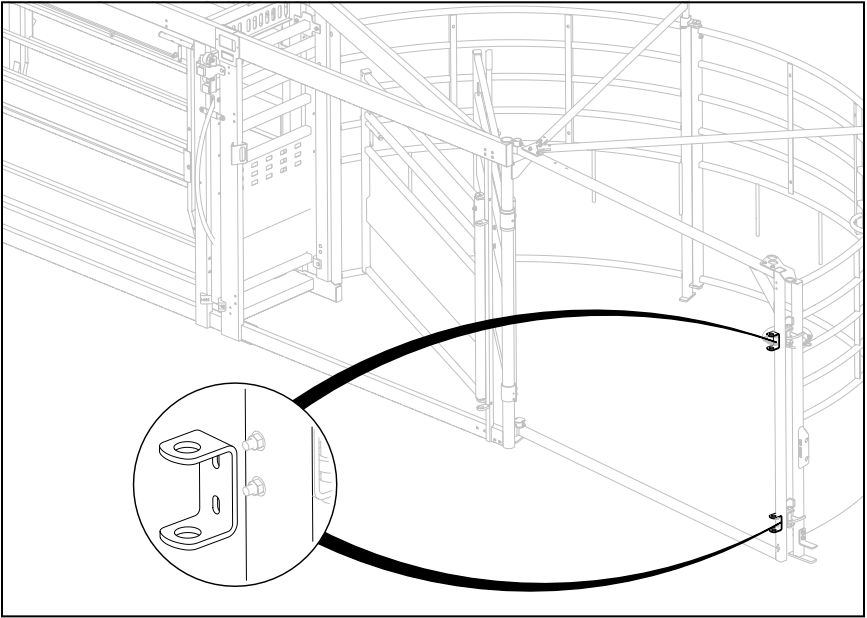

6. Use the pre-installed hardware in the curved panel to install the panel clips from step 5 onto curved panel where shown.

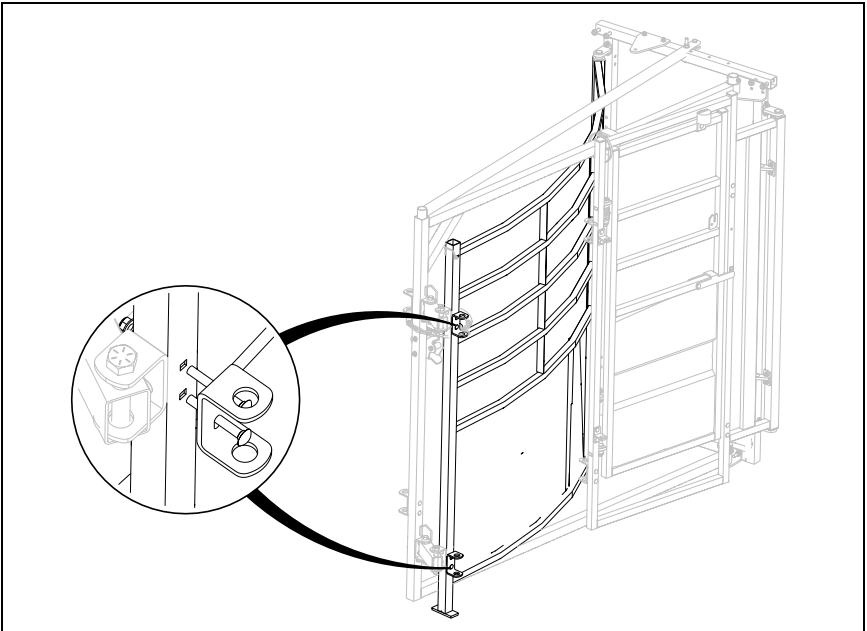

7. Cut zip tie securing the 3E man door (2023310). Discard zip tie and shipping foam.

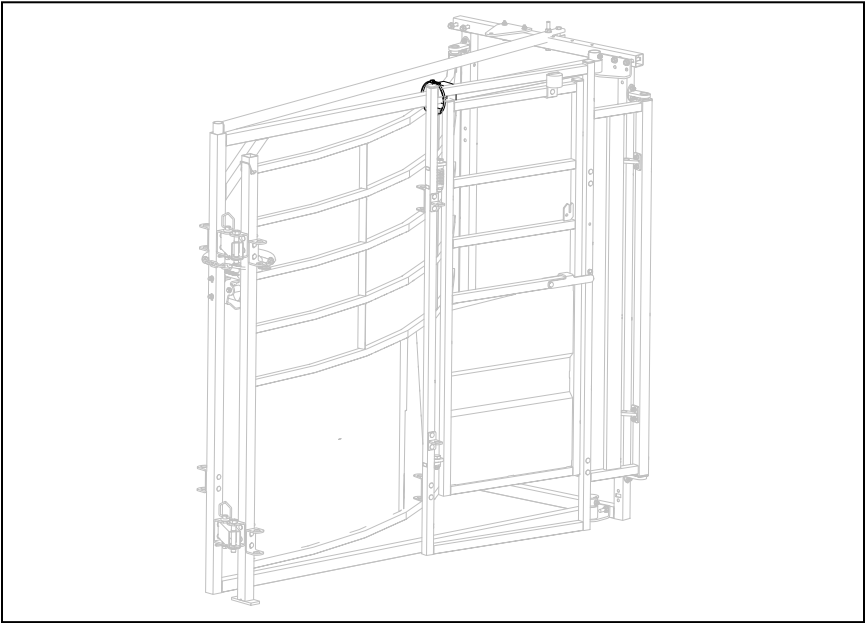

8. With 3E door (2023310) supported, remove 3/8" x 3" hex head bolt (7003203), nut (7003178) and washer (7002300). Set them aside.

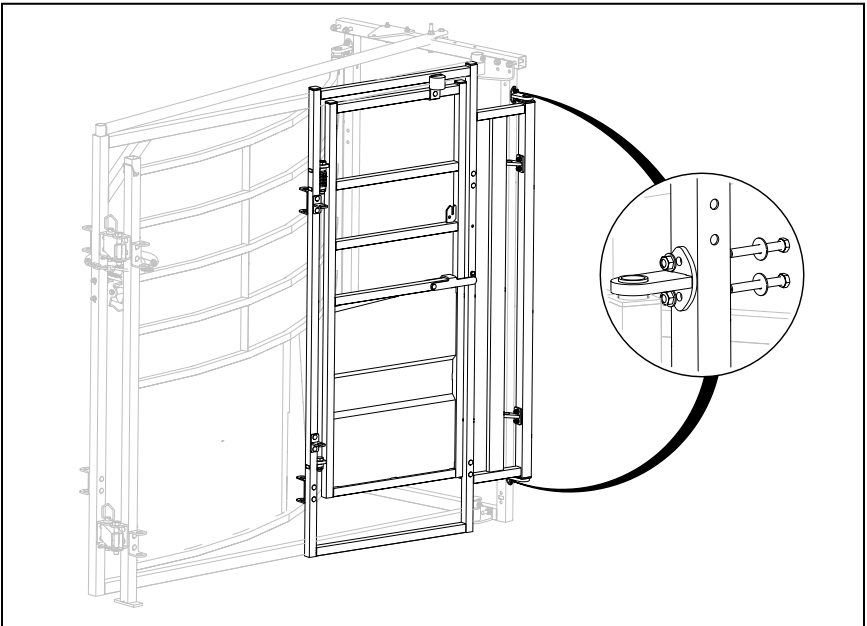

9. Remove bottom bolt on hinge (2025246) from 3E door.

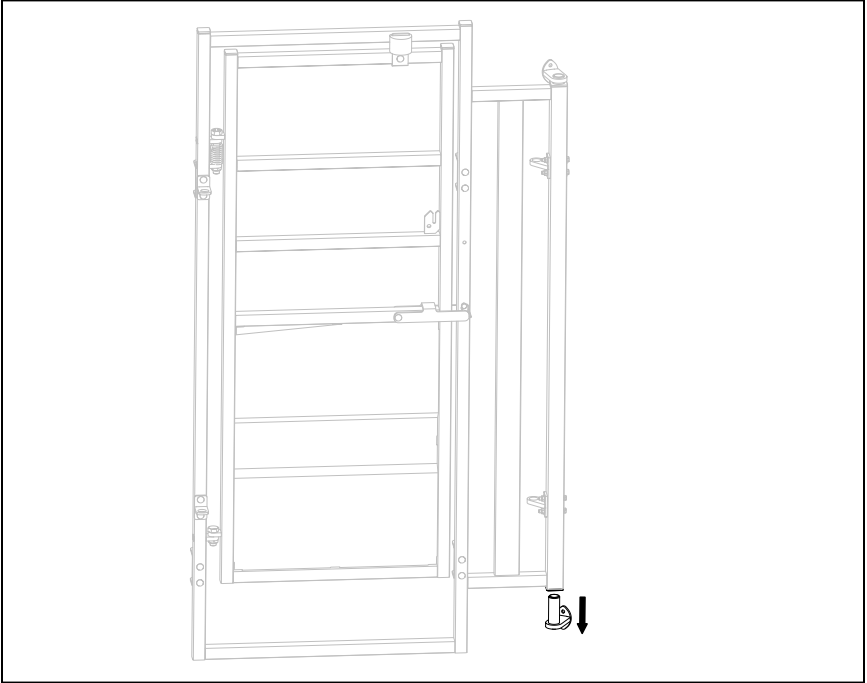

10. Using hardware from step 8 bolt bottom hinge to main frame.

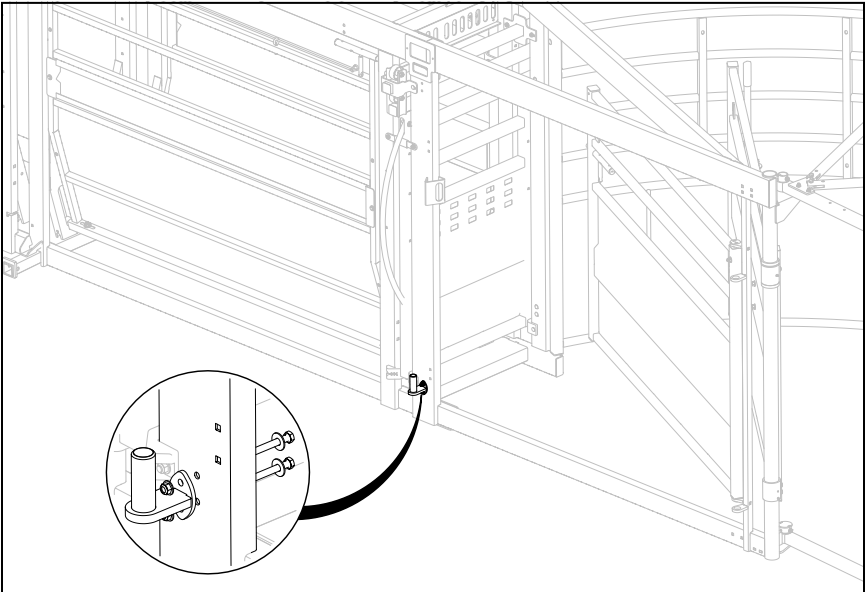

11. 3E door can be lowered onto installed hinge in orientation shown

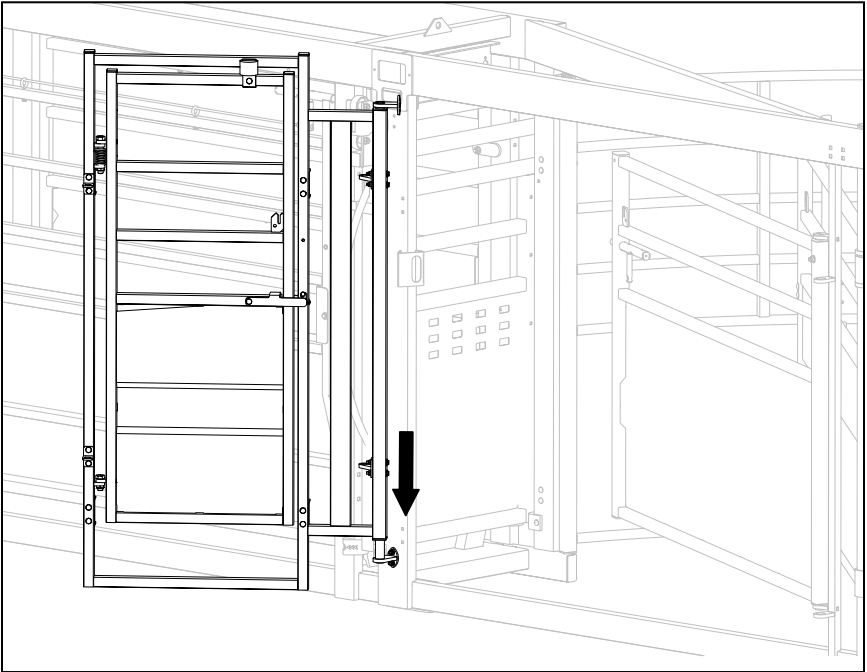

12. Fasten top hinge with hardware from step 8.

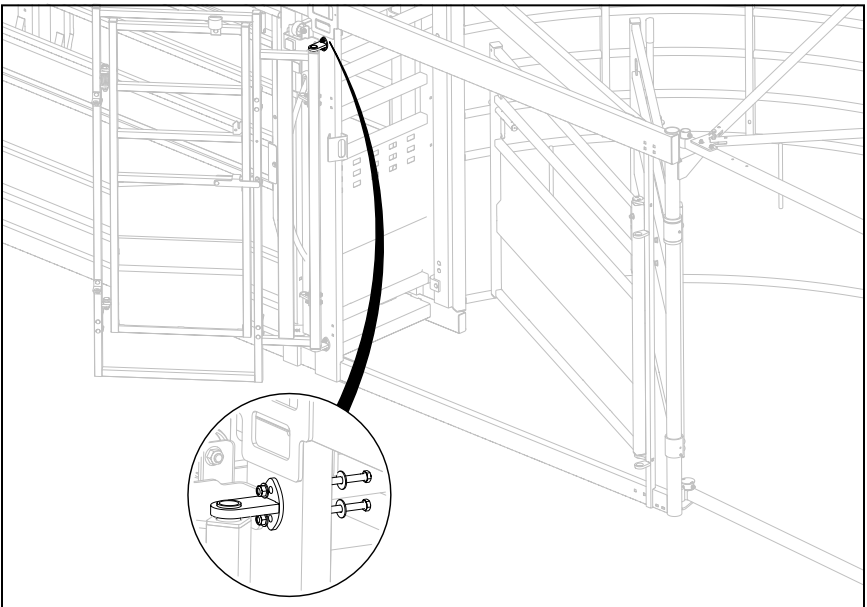

13. To unfasten the curved panel from the frame, support the panel and remove 3/8" x 3" hex head bolt (7003203), nut (7003178) and washer (7002300). Set aside for later.

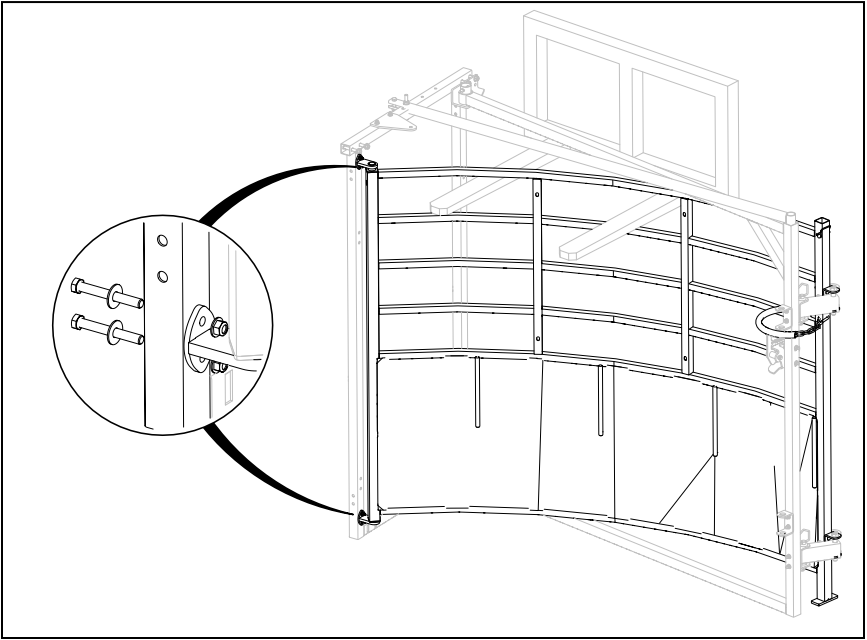

14. Remove 3/4" hardware and discard.

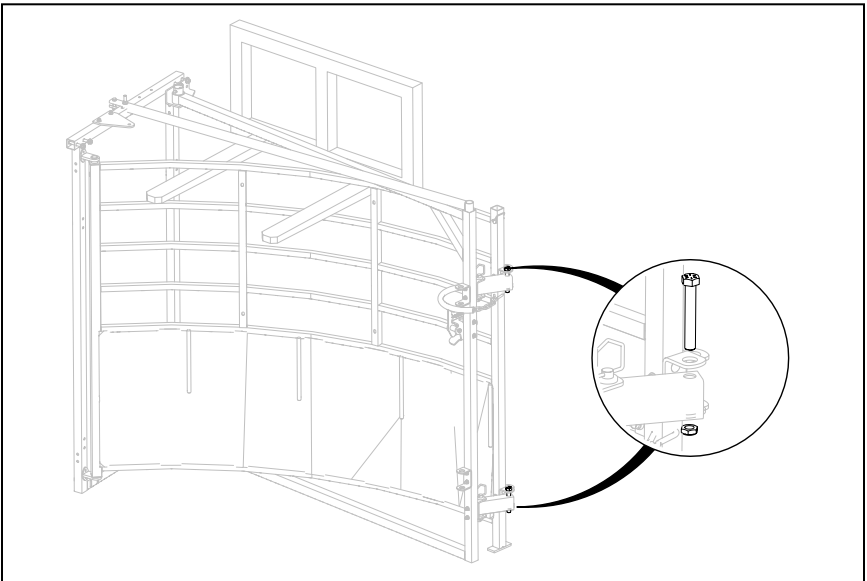

15. Curved panel assembly can now be separated from the main shipping bundle.

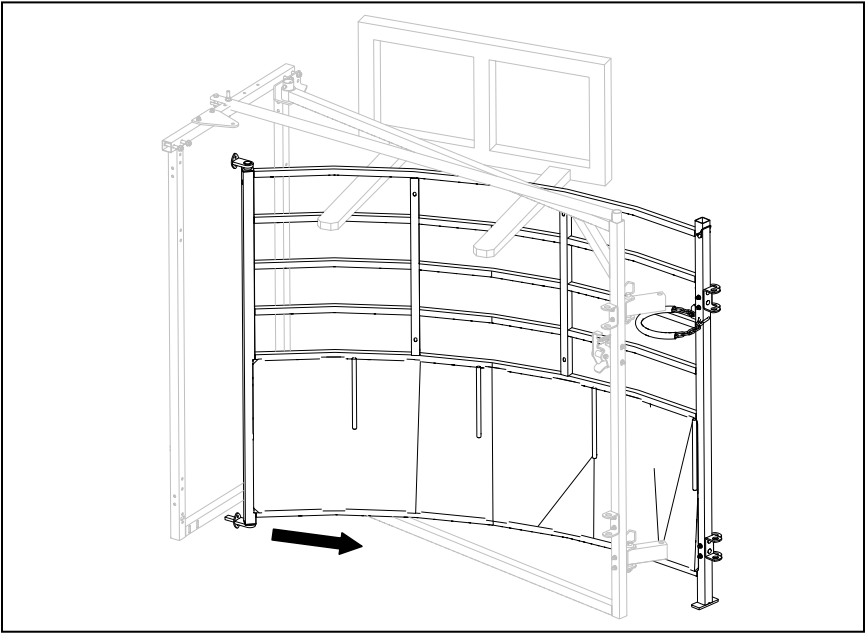

16. Remove bolt on hinge (2002503) from bottom of curved panel.

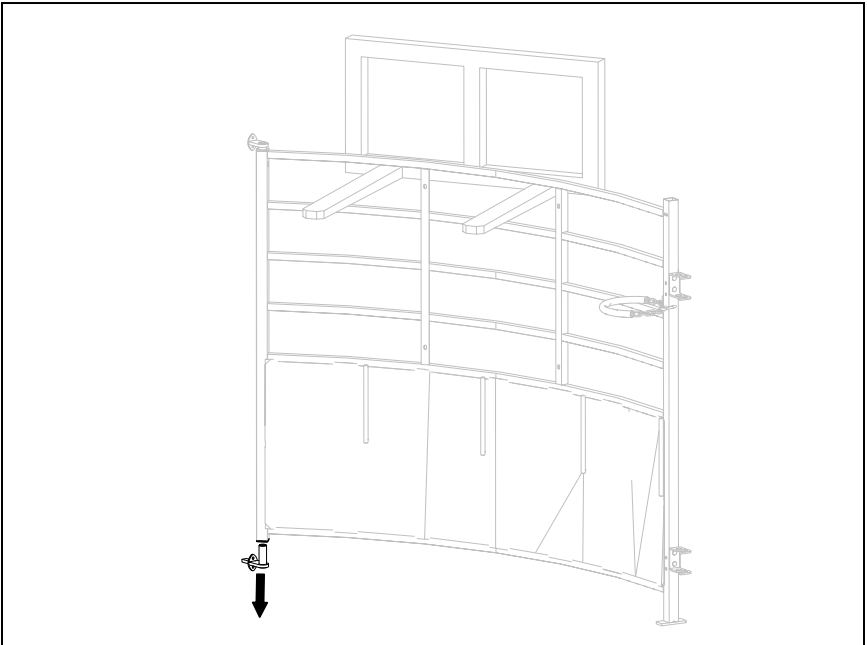

17. Use hardware from step 13 to install the bolt on hinge where shown on the main tub bow.

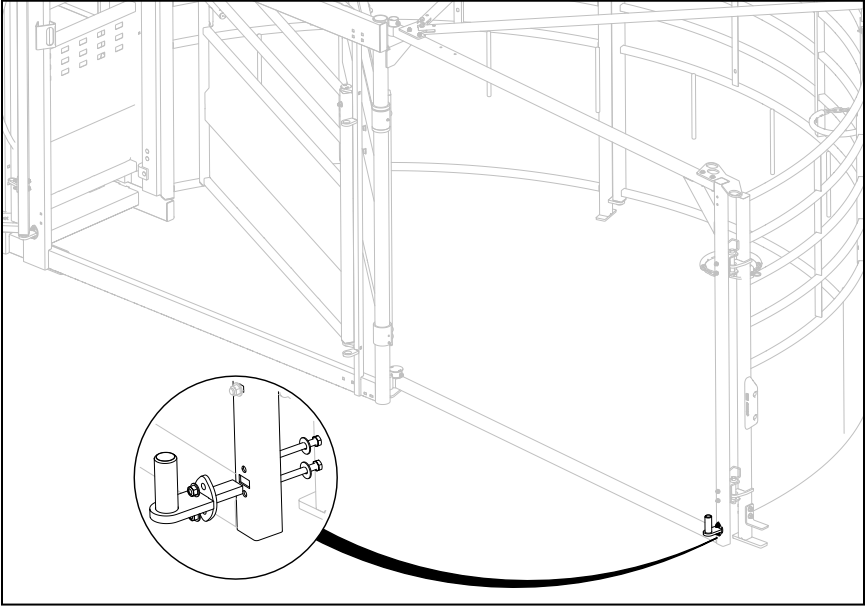

18. Curved panel assembly can now be lowered onto hinge.

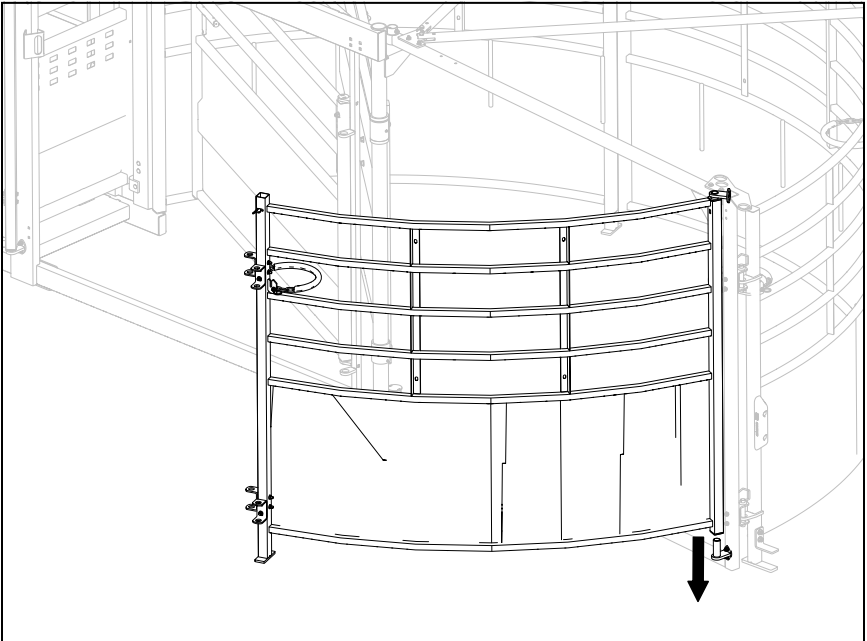

19. Top hinge can now be fastened using the hardware removed in step 13.

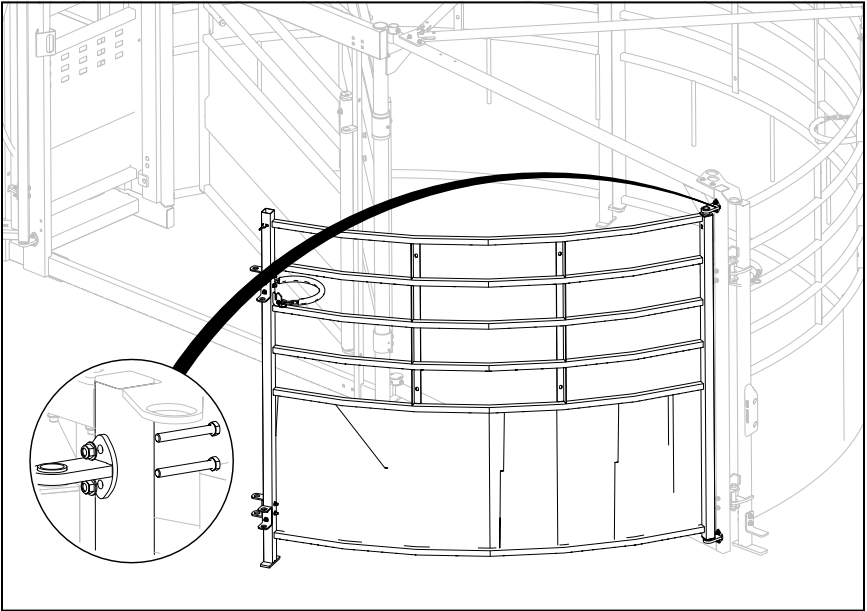

20. Remove joiner bar mount plate (2025217) from the shipping bow by unfastening 3/8" x 3" hex head bolt (7003203), nut (7003178) and washer (7002300).

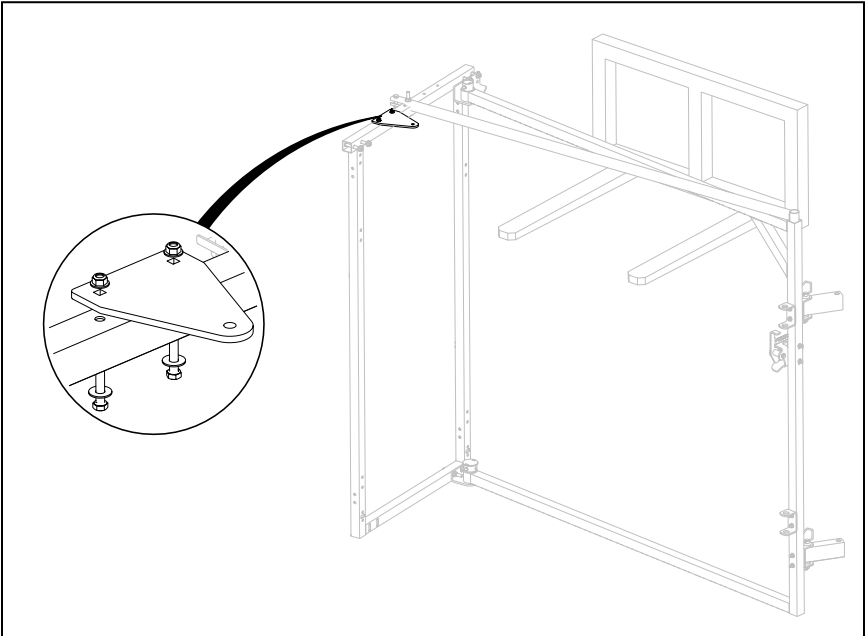

21. Mount joiner bar mount plate to main tub bow where shown. Use the hardware removed in the previous step.

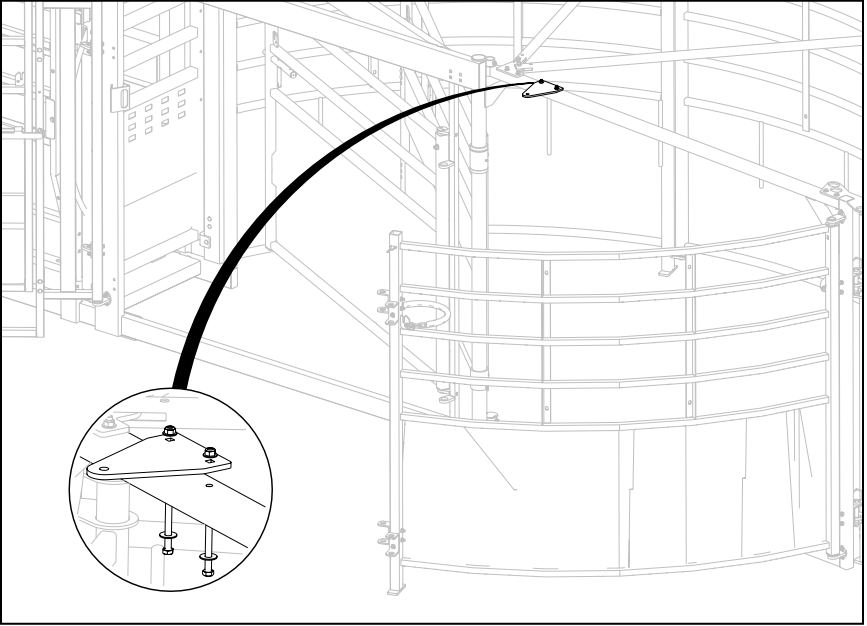

22. Remove 1/2" hardware securing BudFlow joiner bar (2023900) to the shipping bow and remove joiner bar. Hardware can be discarded.

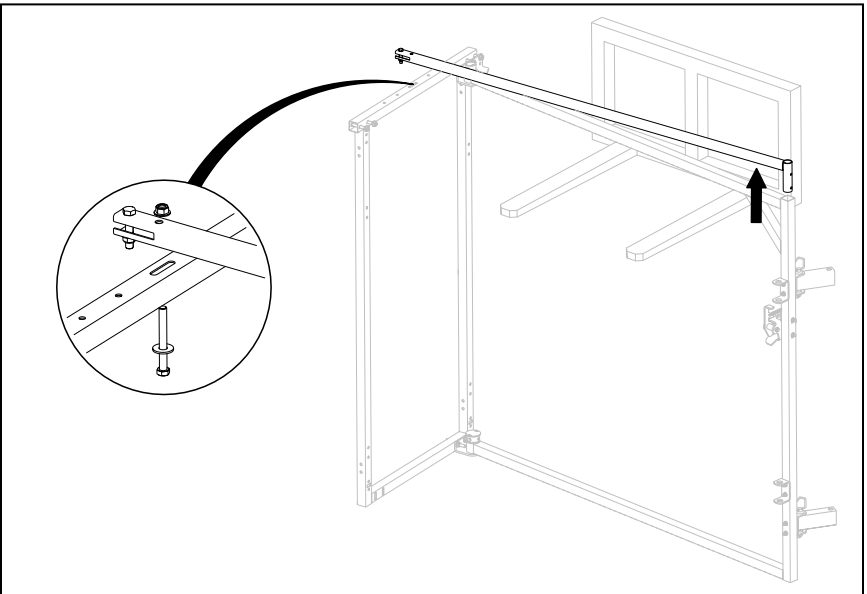

23. Rest one end of the joiner bar into its transport position and fasten the opposite end to the joiner bar mount plate using the pre-installed 1/2" x 2.5" hex bolt (7002285) and nut (7003177).

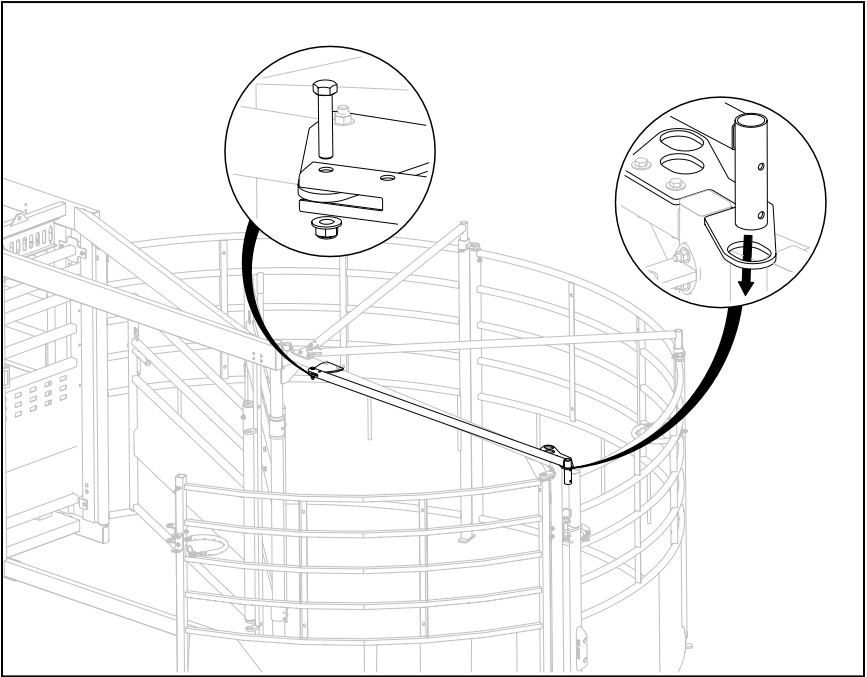

WARNING

THE FOLLOWING INSTRUCTIONS WILL NO LONGER ALLOW THE SHIPPING BUNDLE TO STAND ON ITS OWN. ENSURE ADEQUATE SUPPORT IS GIVEN THE BUDFLOW BOW AND SHIPPING BOW TO PREVENT POTENTIAL INJURY.

24. With BudFlow bow and shipping bow supported, remove the bottom pivot cap (2026537) by unfastening 3/8" x 3" hex head bolt (7003203) and nut (7003178). Set aside cap and hardware for later.

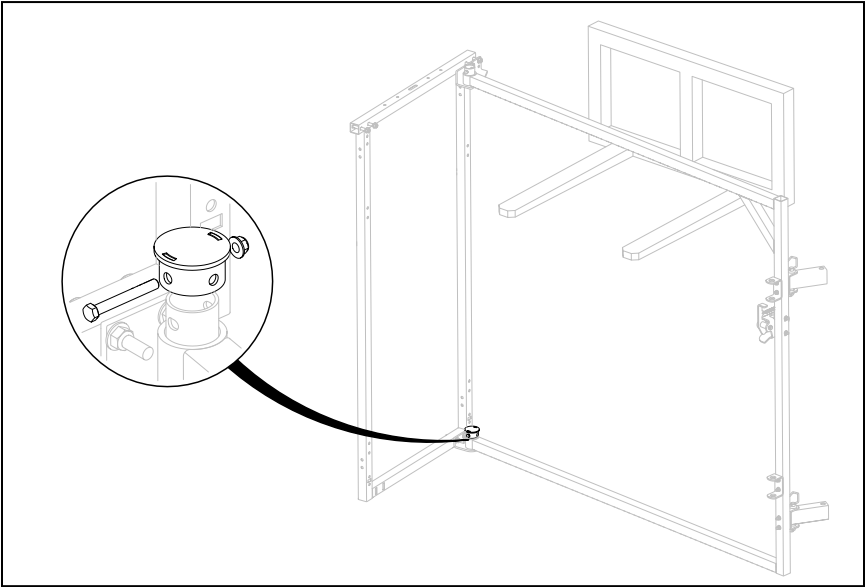

25. Remove the 1/2" x 3" carriage head bolts (7002295) and nuts (7003177) from the top of the shipping bow. Set aside for later.

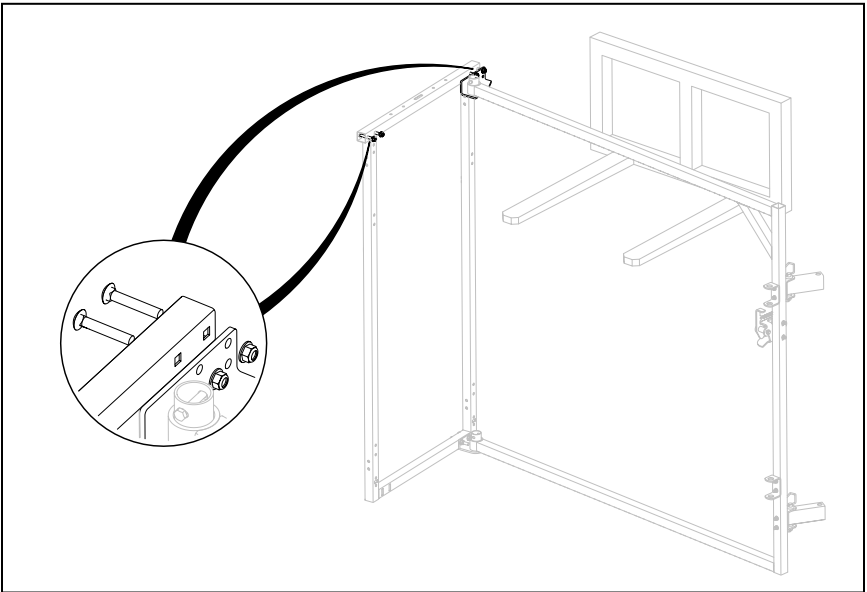

26. Lift the BudFlow bow (2024618) off the shipping bow.

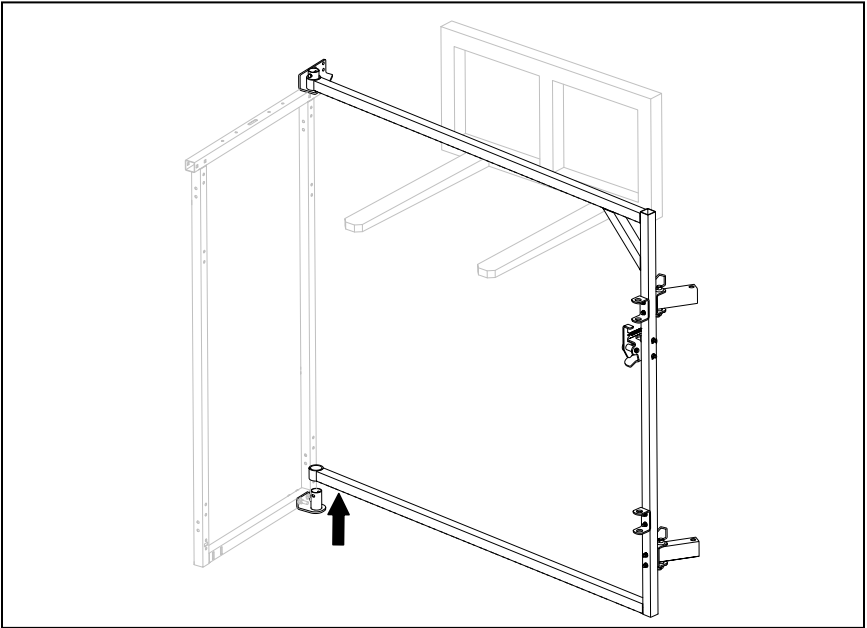

27. Remove bottom pivot (2024675) by unfastening 1/2" x 4" carriage head bolts (7002766) and nuts (7003177). Set aside.

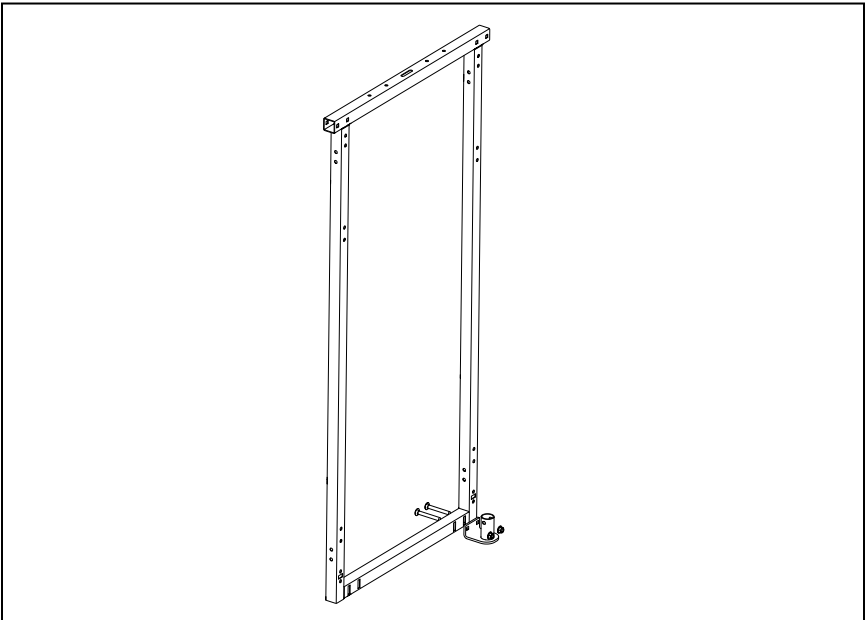

28. Use hardware from previous step to install the bottom pivot where shown on frame.

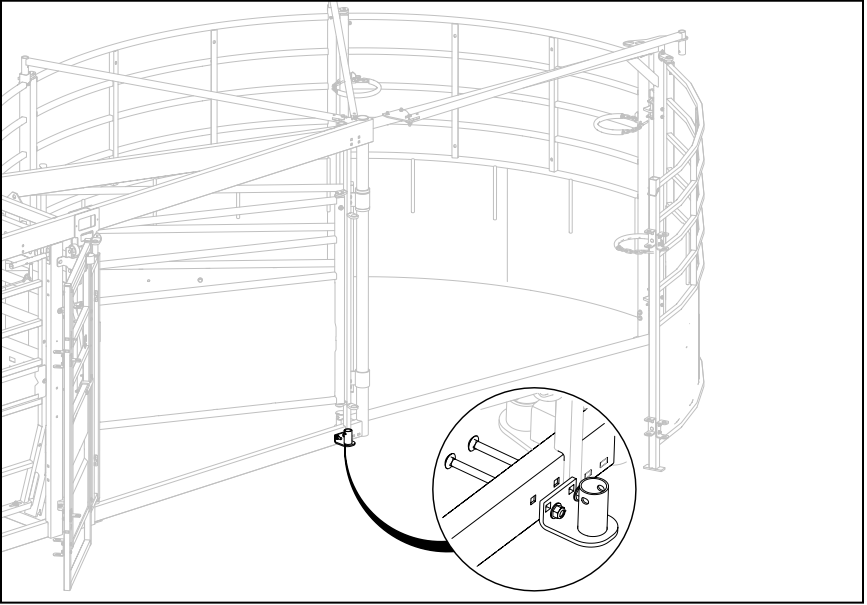

29. Lower BudFlow bow onto bottom pivot.

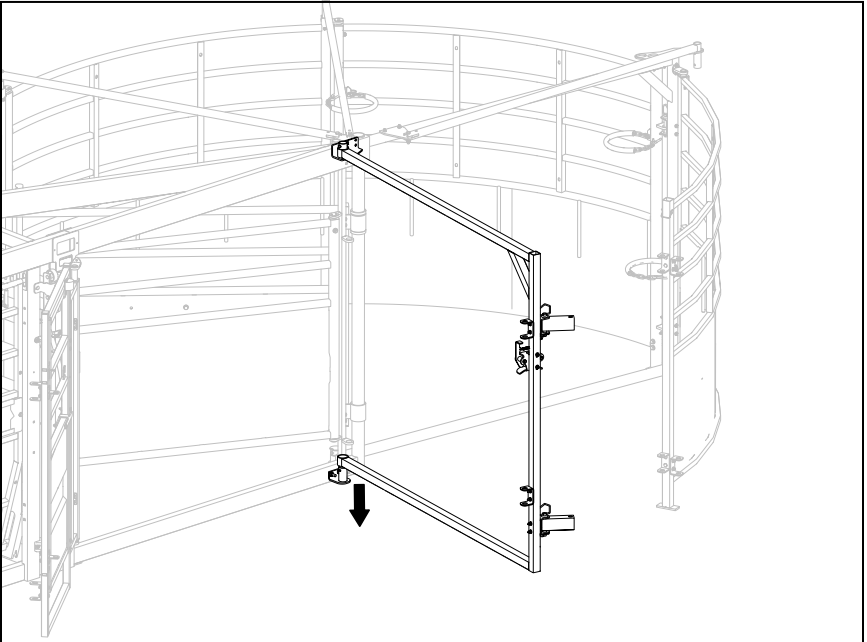

30. Fasten top pivot to the main frame using the 1/2" x 4" carriage head bolts (7002766) and nuts (7003177) set aside in step 27.

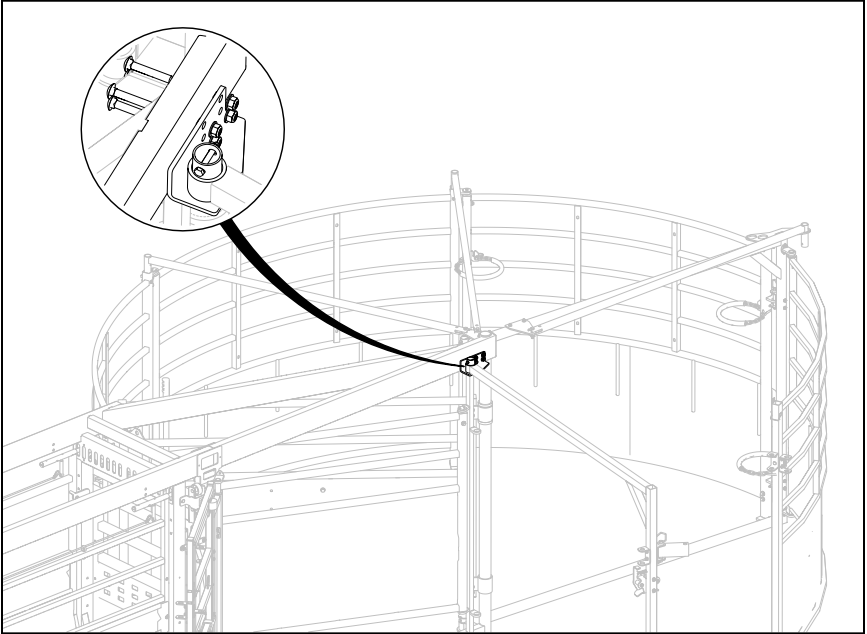

31. Install the bottom pivot cap (2026537) with the 3/8" x 3" hex head bolt (7003203) and nut (7003178) set aside in step 24.

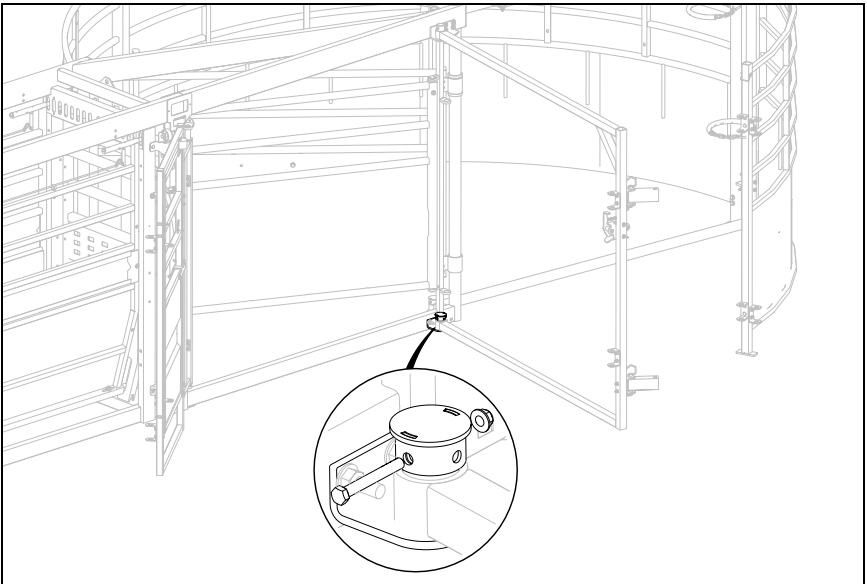

32. Remove pins (7002108) and set aside. Discard shipping tubes.

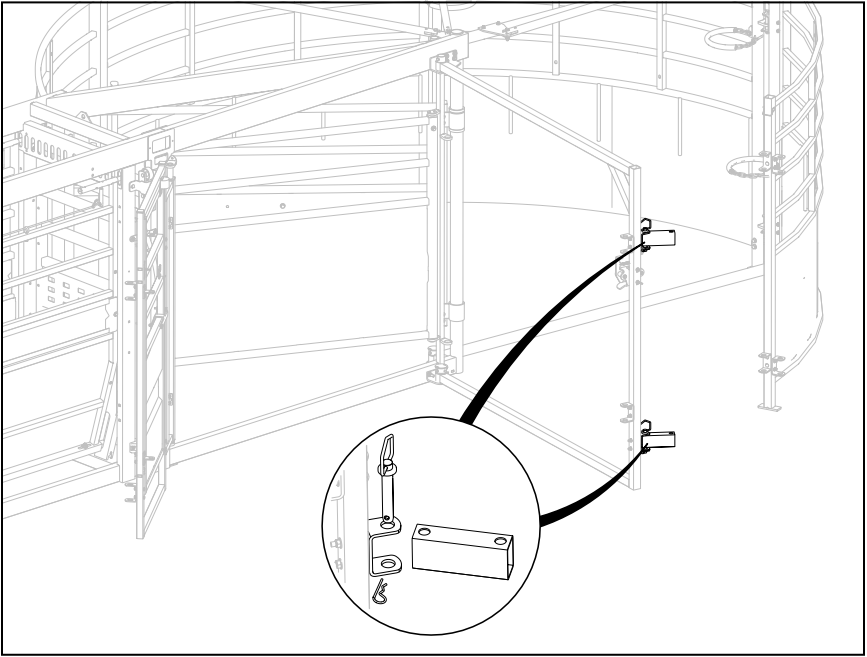

33. Use pins to join the main bow and man door.

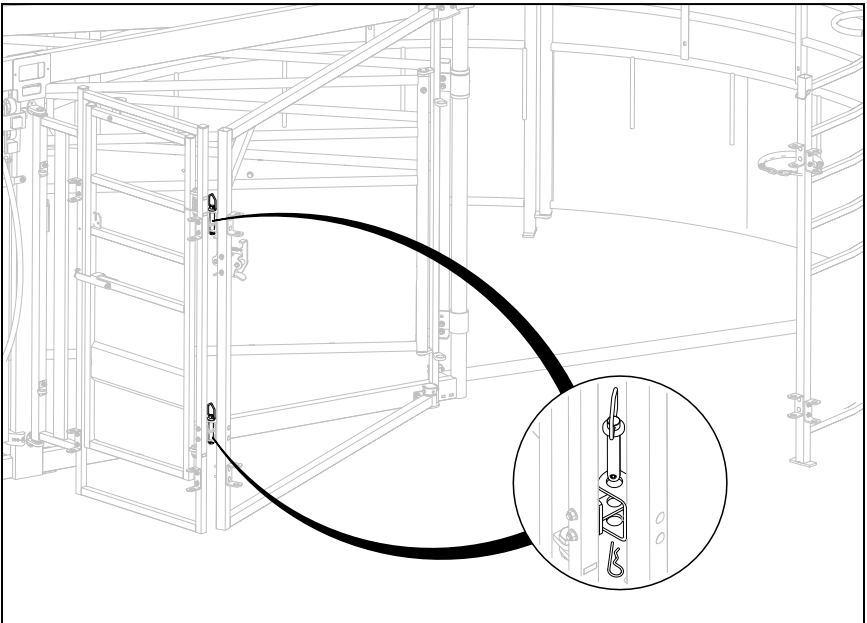

34. Move the top joiner bar into the curved BudFlow panel and secure with preinstalled lynch pin (7002103).

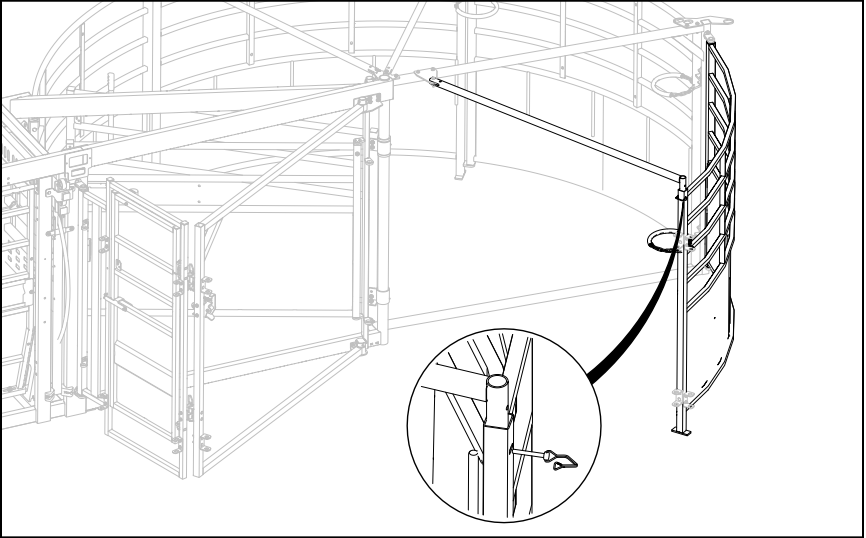

YOUR PORTABLE BUDFLOW TUB IS NOW READY FOR USE. INSTRUCTIONS TO FOLD THE UNIT FOR TRANSPORT CAN BE FOUND IN THE PRODUCT MANUAL.

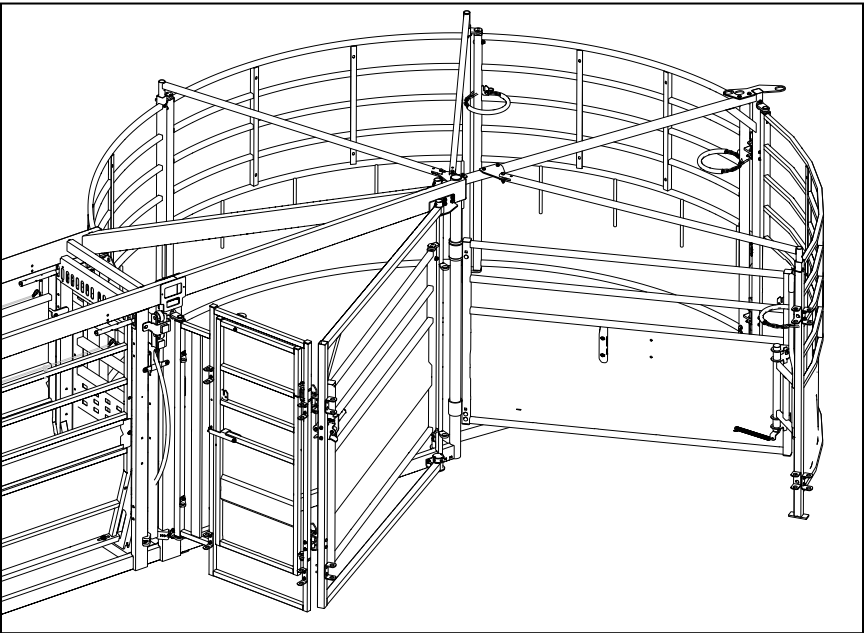

NOTE: The shipping bundle consists of multiple components. Below is a visual of the parts and hardware you will have left over.

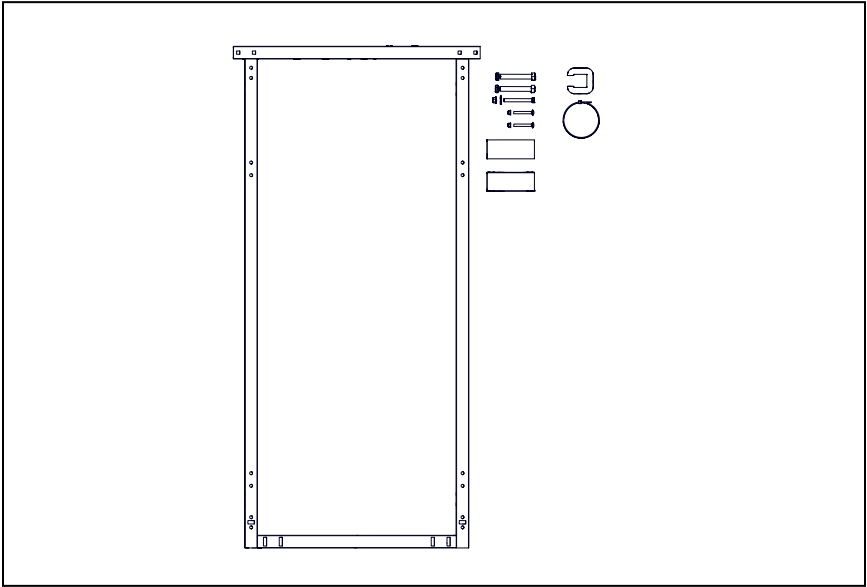

OPERATING GUIDELINES



WARNING:

DO NOT OVERCROWD YOUR CATTLE TUB. MAXIMUM 3-4 ADULT CATTLE AT A TIME.

For instructions on how to fold and unfold your cattle tub, go to **TRANSPORTING THE POWERLOCK 108 SERIES PORTABLE WORKING SYSTEM ON PAGE 9.**

USING THE 3E BUDFLOW TUB

1. Guide cattle into the tub.

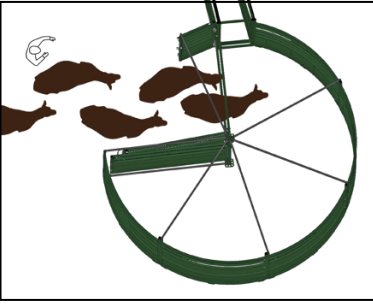

2. Close the entry gate.

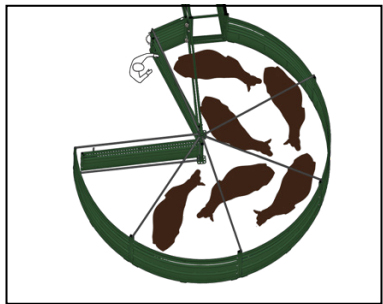

3. Cattle naturally turn back to where they entered.

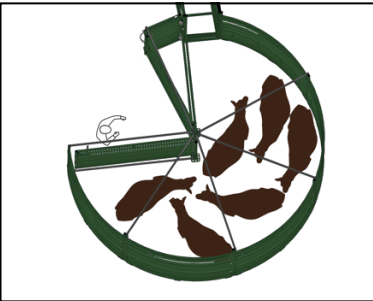

4. If needed, use the swing gate to guide cattle into the alley.

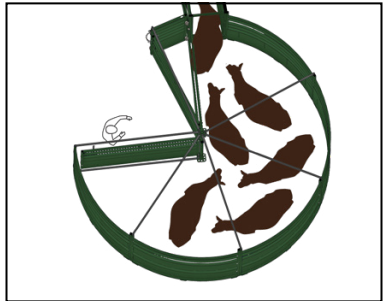

RECOMMENDED MAINTENANCE

THIS SECTION CONTAINS:

- Maintenance Safety
- Cattle Chute Maintenance
- Hydraulic Maintenance
- Power Pack Maintenance
- Hydraulic Jack Maintenance
- Battery Maintenance
- Wheel Maintenance

All Arrowquip Products are made with precision parts to require minimal maintenance. However, regular maintenance will keep your equipment running smoothly and safely.

MAINTENANCE SAFETY

1. Ensure the area is clear of bystanders, especially children, when doing any maintenance or repair on the hydraulic squeeze chute.
2. Keep all body parts, including hair, hands, feet, etc., away from the machine when hydraulics are in operation.
3. Before carrying out any maintenance on the squeeze chute, please ensure there are no livestock in the chute.
4. **DO NOT** repair the chute or go into the chute when hydraulics are in operation. This can result in injury to the worker. Unplug the motor before performing any necessary repairs or inspection.

REGULAR MAINTENANCE

- Inspect the entire unit. Ensure all moving components are free of debris and functioning properly. Use proper cleaning and troubleshooting steps, if necessary.
- Grease cylinders and zerks.
- Lubricate slam latches and door hinges with WD-40 Dry Lube.
- Check gate latches and striker plates for wear. Ensure gates are locking securely.
- Clean bottom head gate door track to prevent dirt build-up.
- Clean the chute floor. Excess build-up of manure or dirt inside chute can cause the squeeze and head gate to malfunction.
- Check mechanism pivot bolts for wear. Lubricate with WD-40 Dry Lube as necessary.

HYDRAULIC MAINTENANCE

If you have any issues with your hydraulic chute, contact Arrowquip Client Care at 1-877-275-6075.

1. Replace oil annually, or more frequently as necessary.
 - a. Dirty oil or oil that has 0.05% of water in it can be catastrophic for hydraulic systems. Replace oil frequently to prevent damage to your hydraulic jacks and keep them working safely and reliably.

POWER PACK MAINTENANCE

Inspect the entire unit. Ensure all moving components are free of debris and functioning properly.

Use proper cleaning

HYDRAULIC JACK MAINTENANCE

1. Replace oil annually, or more frequently as necessary.
 - a. Dirty oil or oil that has 0.05% of water in it can be catastrophic for hydraulic systems. Replace oil frequently to prevent damage to your hydraulic jacks and keep them working safely and reliably.
 - b. The unit requires 14qt of AW22 oil.
2. Keep the solar panel clean.
 - a. To ensure the Solar Panel can do its job and keep your battery functioning properly, ensure the panel is clean and exposed to sunlight regularly.
3. Retract the jacks fully, every time they are used.
 - a. To keep the jacks properly synchronized, it is essential that the cylinders are retracted fully until they stop moving every time they are used.

BATTERY MAINTENANCE

1. Charge the battery as required with a 12V AGM battery charger.
 - a. Connect charger to external Battery Lugs, as per battery manual.

BATTERY REPLACEMENT

If battery replacement is required, ensure replacement is of the same specs. Batteries with the wrong specs will void the warranty.

WHEEL MAINTENANCE

It is extremely important to apply and maintain proper wheel mounting torque on your trailer wheel. Torque is a measure of the amount of tightening applied to a fastener (nut or bolt) and is expressed as length force. For example, a force of 90 pounds applied at the end of a wrench on foot long will yield 90 ft. lbs. of torque. A torque wrench is the best method to assures the proper amount of torque is being applied to a fastener.

Be sure to use only fasteners matched to the cone angle of your wheel – usually 60° or 90°. The proper procedure for attaching your wheels is as follows:

1. Start all bolts or nuts by hand to prevent cross-threading.
2. Tighten bolts or nuts in the sequence shown for wheel torque requirements.
3. The tightening of the fasteners should be done in stages. Following the recommended sequence, tighten fasteners per wheel torque requirements diagram.
4. Wheel nuts/bolts should be torqued before first road use and after each wheel removal. Check and re-torque after the first 10 miles, 25 miles, and again at 50 miles. Check periodically thereafter.

Maximum torque level that can be safely applied to the studs are: Stud Size: .5"-20 UNF, class 2A

Maximum Torque: 120ft. lbs.

TROUBLESHOOTING GUIDE

Before doing ANY work or troubleshooting on your hydraulic chute, contact Arrowquip Client Care at 1-877-275-6075.

SQUEEZE CHUTE

1. To ensure proper operation make sure head gate is situated on level ground or base.
2. Make sure head gate door tracks are free of debris.
3. Keep floors clean. Excess build-up of manure or dirt inside chute can cause the squeeze and head gate to malfunction.
4. Lubricate slam latches and pivot points with WD-40 Dry Lube.

108 SERIES POWER PACK TROUBLESHOOTING

GAS POWER PACK ISSUES

For detailed instructions on how to remedy these problems, refer to your Gas Power Pack manual.

PROBLEM	Possible Cause							
	No Fuel	Improper Fuel	Dirt In Fuel Line	Dirty Debris Screen	Incorrect Oil Level	Engine Overloaded	Dirty Air Cleaner	Faulty Spark Plug
Will Not Start	•	•	•		•	•	•	•
Hard Starting		•	•		•	•	•	•
Stops Suddenly	•		•	•	•	•	•	•
Lacks Power		•	•	•	•	•	•	•
Operates Erratically		•	•	•		•	•	•
Knocks or Pings		•		•		•		•
Skips or Misfires		•	•	•			•	•
Backfires		•	•			•	•	•
Overheats		•	•	•	•	•	•	
High Fuel Consumption						•	•	•

GAS POWER PACK START CORD IS DIFFICULT TO PULL

SOLUTIONS:

1. It is possible the motor has been turned on its side at some point, causing oil to get on top of the cylinder. Remove spark plug, hold a rag over spark plug hole, and pull the start cord a couple of times to get rid of the oil. Clean and dry out spark plug hole, then check engine oil.

NOTE: Engine will smoke at first as it burns off the oil.

2. Reconnect hoses which may not be connected properly.

PUMP IS NOT BUILDING PRESSURE

SOLUTIONS:

1. Try screwing relief on the valve block all the way in and then back out. Keep track of turns and adjust accordingly.
2. Check that the hydraulic oil level is correct in the sight glass. Use HVI22 or AW22 weight oil to fill as needed.
3. Make sure that both couplers are engaged, and the female sleeve is snapped into place.
4. Ensure fan on motor is turning clockwise.
5. If the cold start valve is stuck in the open/up position, turn the valve one quarter turn and pin should slide down deeper.
6. If it sounds like the motor is not laboring, there is a very small possibility that the key on the shaft broke, and it is not turning the pump.
7. If the relief valve has a piece of debris in it, turning the valve in and out it should free it and cause it to by-pass.
8. Make sure hoses are hooked up correctly and align with the P and T on both the power pack and the chute.

NOTE: 'P' is left and 'T' is right.

ISSUES WITH ELECTRIC POWER PACK

Contact your Electrician for assistance with any Power Pack issues.

For additional information, contact Arrowquip Client Care at 1-877-275-6075.

HYDRAULIC JACKS

1. Rear jacks are not synchronized.
 - a. If one cylinder is contacting the ground significantly ahead of the other, retract the jacks all the way up and deadhead the jacks until both are as far retracted they can go.
 - This should be done every time the jacks are retracted.
 - b. Extend the jacks again to see if the feet are synchronized and contacting the ground at the same time.
 - c. If the jacks are still not synchronized when they hit the ground, ensure the unit is charged fully or boost with jumper cables.
 - d. When both jacks are contacting the ground simultaneously, it is safe to lift the unit.
2. Battery is dead and/or the unit will not function.
 - a. Ensure pendant button is working.
 - Listen for the click of the relay when button is pressed. If it makes a

clicking sound, the relay is activating.

- b. If the system seems dead and no functions are working, it is likely the battery may be low and in need of charge.
- c. Use an AGM Battery Charger to charge the unit, or boost by attaching jumper cables to the charging lugs on the outside of the box.
 - Arrowquip recommends Genius 26000 Charger.
3. Slow function in extreme cold weather.
 - a. If the unit has been sitting outside in extremely cold temperatures, it is possible that the oil is thicker than normal, and the jacks may operate slower than at warmer temperatures.
4. Unusual sound coming from the pump.
 - a. If it sounds like there is air getting into the hydraulic system, there is likely not enough oil in the reservoir.
 - b. Fully retract all cylinders.
 - c. Check the oil level in the reservoir.
 - d. The oil level should be just below the edge of the port.
 - e. Fill or replace the oil, as necessary.

MANUAL JACKS

1. Manual winder is stiff.
 - a. Check that bearings are oiled.
 - b. check for obstructions.
 - Inspect moving components of the jacks, to ensure nothing is damaged or obstructing normal operation.
2. Manual winder is locked solid.
 - a. Check that bearings are not seized.

RECOMMENDED USE

5,000 head of cattle per year

Follow the recommended use to maximize the lifespan of your equipment. Arrowquip products that have only been used within acceptable tolerance following the recommended use will be eligible to claim warranty.

WARRANTY

Your product must be registered to claim warranty, and to ensure that Arrowquip has the required information to contact you in the event of a product or part recall. Any owner who fails to register their product warranty with Arrowquip through their Authorized Arrowquip Dealer voluntarily voids their warranty. Arrowquip will repair or replace products or parts of a product that prove defective due to manufacturer defect during the Warranty Period, at their sole discretion. This excludes defects resulting from normal wear and tear or product misuse.

NOTE: Any modification, in any fashion, to any arrowquip equipment immediately voids the product warranty. This includes the parts contained therein.

E.g. If a modification is made to the squeeze mechanism in a squeeze chute, and the sternum bar is bent afterwards, warranty for the damaged part, the sternum bar, contained in the modified equipment, the squeeze chute, is void. In addition, any remaining warranty for the squeeze chute and other parts contained therein, including, but not limited to, the head gate, locking system, Q-Catch system, and rollers, is null and void.

REGISTER FOR WARRANTY NOW:

ONLINE: arrowquip.com/product-registration

PHONE: 1-877-275-6075 | **EMAIL:** cs@arrowquip.com



If you have any questions regarding your product or require assistance, please contact Arrowquip's Client Care Team at **1-877-275-6075** or by email at **cs@arrowquip.com**

arrowquip.com

