

Freestanding Fire Pit

ecosmart⁺
Fire

Nova Series



ecosmartfire.com

Nova Series Design features



1. Fluid™ Concrete

Incredibly strong yet relatively lightweight, EcoSmart's concrete products incorporate revolutionary Fluid Concrete Technology. Fluid features a stain and impact-resistant barrier that protects the concrete from environmental weathering – even under extreme conditions and long UV exposure.

Environmentally-Friendly

Bioethanol fireplaces use an environmentally-friendly, renewable energy source that burns clean and delivers warming heat. You and your guests will enjoy the ambiance and tranquility of a real fire, without the hassles of burning real wood - no more embers, ash, and soot to clean up.

Surround Colours

Our fires are available in three Fluid Concrete colours.



Natural



Graphite



Bone

2. Decorative Media

Concrete models come with black glass charcoal.

3. Articulating Feet

Our Fire Pits and Tables feature 360° height-adjustable articulating feet, so you can achieve a perfectly level and stable model before operating the fireplace.

Versatile & Incredibly Durable

EcoSmart portable fireplaces are versatile, incredibly durable, and are constructed of weather resistant materials. These appliances are designed to look great for years, and will perform admirably through all four seasons.

4. Burner Colours

Available with a Stainless Steel or Black Burner.

Available in 2 Sizes

Nova 850 stands 310mm [12.2in] tall, 850mm [33.5in] wide. The smaller Nova 600 stands 220mm [8.7in] tall, 600mm [23.6in] wide.

Quick & Easy Installation

With no installation or building works required, simply unpack, put into position, and off you go.

Ground Fixing Brackets

Models come with fixing brackets for permanently locating into a fixed position.

Global Compliance

These models comply with existing standards in the USA and Australia. UL Listed and ACCC Safety Mandate compliant.

Included Accessories



Jerry Can with Safety Spout & e-NRG bottle adaptor



Lighting Rod & Lighter



AB8 Efficiency Ring
(Nova 850 only)



Jerry Can Spout Extension
(Nova 600 only)



Black Glass Charcoal

Optional Accessories



Outdoor Covers





Disclaimer: All product specifications and data are subject to change without notice and believed to be correct at the time of publication. MAD Design Group (MDG), its affiliates, agents, and employees, and all persons acting on its or their behalf (collectively, "MAD Design Group"), disclaim any and all liability for any errors, inaccuracies or incompleteness contained herein or in any other disclosure relating to any product. MDG disclaims any and all liability arising out of the use or application of any product described herein or of any information provided herein to the maximum extent permitted by law. The product specifications do not expand or otherwise modify MDG's terms and conditions of purchase, including but not limited to the warranty expressed therein, which apply to these products. No license, express or implied, by estoppel or otherwise, to any intellectual property rights is granted by this document or by any conduct of MDG. Customers using or selling MDG products not expressly indicated for use in such applications do so entirely at their own risk and agree to fully indemnify MDG for any damages arising or resulting from such use or sale. Please contact authorised personnel from MDG to obtain written terms and conditions regarding products designed for such applications. Images are indicative only.

Nova 850 Specifications

Stylish, clean-lined design combined with durable Fluid™ Concrete construction, Nova 850 is a simple yet contemporary fire pit for enhancing outdoor living spaces.

Burner Ventilation and Efficiency*

Dimensions L x W x H mm/in	Compatible Burner	Fuel Capacity	Heats on Average (Indoors)	Thermal Output Net (MAX)	Approx. Burn Time	Minimum Room Size
850 x 850 x 310 33.5 x 33.5 x 12.2	AB8	8 L [2.1 Gals]	Over 60 m ² [645 ft ²]	21.56 MJ/h 20,433 BTU/h 5.99 kW	7 - 9 hours	116 m ³ [4,096 ft ³]

Application	Outdoor
Surround Colours	<div style="display: flex; justify-content: space-around; align-items: center;"> <div style="text-align: center;">  <p>Natural ESF.O.NOV.850.NA</p> </div> <div style="text-align: center;">  <p>Graphite ESF.O.NOV.850.GH</p> </div> </div> <div style="text-align: center; margin-top: 10px;">  <p>Bone ESF.O.NOV.850.BO</p> </div>
Burner Colours	<div style="display: flex; justify-content: space-around; align-items: center;"> <div style="text-align: center;">  <p>Stainless Steel</p> </div> <div style="text-align: center;">  <p>Black</p> </div> </div>
Materials	Fluid Concrete Surround, Grade 304 Stainless Steel Burner, with optional Black Ceramic Coating
Approx. Weight	43.9kg [96.7lbs] Weight includes burner and black glass charcoal.
Fuel Type	e-NRG Bioethanol / e-NRG.com

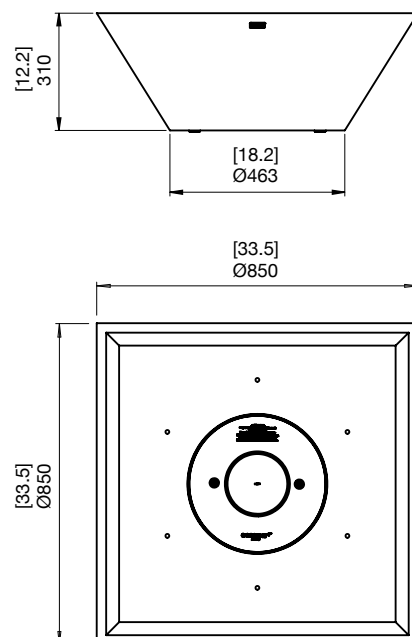

*These values are indicative only and may vary depending on the model purchased, installation, and the seasonal resource used to manufacture e-NRG. This model comes with fixing brackets for permanently locating into a fixed position. This model complies with existing standards in the USA and Australia. UL Listed and ACCC Safety Mandate compliant.







FOR MORE INFORMATION PLEASE REFERENCE THE CLEARANCE & INSTALLATION MANUAL





Disclaimer: All product specifications and data are subject to change without notice and believed to be correct at the time of publication. MAD Design Group (MDG), its affiliates, agents, and employees, and all persons acting on its or their behalf (collectively, "MAD Design Group"), disclaim any and all liability for any errors, inaccuracies or incompleteness contained herein or in any other disclosure relating to any product. MDG disclaims any and all liability arising out of the use or application of any product described herein or of any information provided herein to the maximum extent permitted by law. The product specifications do not expand or otherwise modify MDG's terms and conditions of purchase, including but not limited to the warranty expressed therein, which apply to these products. No license, express or implied, by estoppel or otherwise, to any intellectual property rights is granted by this document or by any conduct of MDG. Customers using or selling MDG products not expressly indicated for use in such applications do so entirely at their own risk and agree to fully indemnify MDG for any damages arising or resulting from such use or sale. Please contact authorised personnel from MDG to obtain written terms and conditions regarding products designed for such applications. Images are indicative only.

Nova 600 Specifications

A linear twist on a modern classic, the weather-resistant Nova 600 (little brother to the Nova 850) is the centre of attention at every gathering.

Burner Ventilation and Efficiency*

 Dimensions L x W x H mm/in	 Compatible Burner	 Fuel Capacity	 Heats on Average (Indoors)	 Thermal Output Net (MAX)	 Approx. Burn Time	 Minimum Room Size
600 x 600 x 220 23.6 x 23.6 x 8.7	AB3	2.5 L [0.7 Gals]	Over 20 m ² [215 ft ²]	6.14 MJ/h 5,800 BTU/h 1.7 kW	8 - 11 hours	40 m ³ [1,413 ft ³]

Application	Outdoor
Surround Colours	 Natural ESF.O.NOV.600.NA  Graphite ESF.O.NOV.600.GH  Bone ESF.O.NOV.600.BO
Burner Colours	 Stainless Steel  Black
Materials	Fluid Concrete Surround, Grade 304 Stainless Steel Burner, with optional Black Ceramic Coating
Approx. Weight	19.9kg [43.9lbs] Weight includes burner and black glass charcoal.
Fuel Type	e-NRG Bioethanol / e-NRG.com

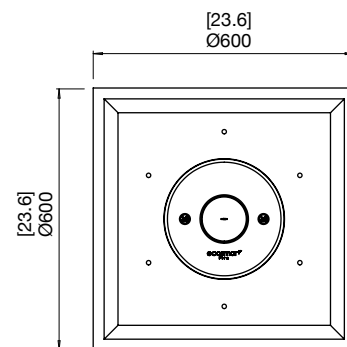
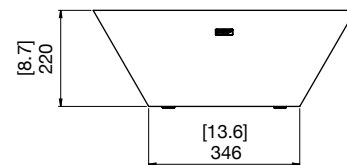

*These values are indicative only and may vary depending on the model purchased, installation, and the seasonal resource used to manufacture e-NRG.

This model comes with fixing brackets for permanently locating into a fixed position.

This model complies with existing standards in the USA and Australia. UL Listed and ACCC Safety Mandate compliant.

FOR MORE INFORMATION PLEASE REFERENCE THE CLEARANCE & INSTALLATION MANUAL

Disclaimer: All product specifications and data are subject to change without notice and believed to be correct at the time of publication. MAD Design Group (MDG), its affiliates, agents, and employees, and all persons acting on its or their behalf (collectively, "MAD Design Group"), disclaim any and all liability for any errors, inaccuracies or incompleteness contained herein or in any other disclosure relating to any product. MDG disclaims any and all liability arising out of the use or application of any product described herein or of any information provided herein to the maximum extent permitted by law. The product specifications do not expand or otherwise modify MDG's terms and conditions of purchase, including but not limited to the warranty expressed therein, which apply to these products. No license, express or implied, by estoppel or otherwise, to any intellectual property rights is granted by this document or by any conduct of MDG. Customers using or selling MDG products not expressly indicated for use in such applications do so entirely at their own risk and agree to fully indemnify MDG for any damages arising or resulting from such use or sale. Please contact authorised personnel from MDG to obtain written terms and conditions regarding products designed for such applications. Images are indicative only.

Freestanding Fireplaces

ecosmar⁺
Fire

Select yours in 3 simple steps

1 Select style



Wharf 65
L 1650 x W 1000 x H 339mm
\$5,995 (Concrete) \$6,495 (Teak)
(includes XL900 Burner & Accessories)



Cosmo 50
L 1270 x W 762 x H 296mm
\$4,495 (Concrete) \$4,995 (Teak)
(includes XL900 Burner & Accessories)



Manhattan 50
L 1270 x W 762 x H 296mm
\$2,495 (Concrete) \$2,995 (Teak)
(includes AB8 Burner & Accessories)



Martini 50
L 1270 x W 762 x H 296mm
\$2,495 (Concrete) \$2,995 (Teak)
(includes AB8 Burner & Accessories)



Ark 40
Ø 1000 x H 339mm
\$2,995 (includes AB8 Burner & Accessories)



Base 40
L 1000 x W 1000 x H 339mm
\$2,995 (Concrete) \$3,495 (Teak)
(includes AB8 Burner & Accessories)



Base 30
L 776 x W 776 x H 339mm
\$2,495 (Concrete) \$2,995 (Teak)
(includes AB8 Burner & Accessories)



Gin 90 Bar
L 2272 x W 1098 x H 1045mm
\$8,995 (Concrete) \$9,495 (Teak)
(includes XL900 Burner & Accessories)



Gin 90 Dining
L 2272 x W 1098 x H 745mm
\$8,695 (Concrete) \$9,195 (Teak)
(includes XL900 Burner & Accessories)



Gin 90 Chat
L 2272 x W 1098 x H 545mm
\$8,395 (Concrete) \$8,895 (Teak)
(includes XL900 Burner & Accessories)



Gin 90 Low
L 2272 x W 1098 x H 345mm
\$8,095 (Concrete) \$8,595 (Teak)
(includes XL900 Burner & Accessories)



Mini T
L 330 x W 330 x H 462mm
\$1,795 (includes AB3 Burner & Accessories)



Mix 850
Ø 850 x H 319mm
\$1,895 (includes AB8 Burner & Accessories)



Mix 600
Ø 600 x H 229mm
\$995 (includes AB3 Burner & Accessories)



Nova 850
L/W 850 x H 310mm
\$1,895 (includes AB8 Burner & Accessories)



Nova 600
L/W 600 x H 220mm
\$995 (includes AB3 Burner & Accessories)



Pod 40
Ø 998 x H 504mm
\$2,495 (includes AB8 Burner & Accessories)



Pod 30
Ø 762 x H 351mm
\$1,995 (includes AB8 Burner & Accessories)



Stix 8
L 792 x W 792 x H 1085mm
\$3,496 (Black Only)
(includes AB8 Burner & Accessories)



Stix
L 557 x W 556 x H 780mm
From \$1,995 (Stainless Steel) \$1,495 (Black)
(includes AB3 Burner & Accessories)

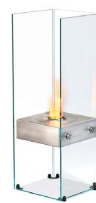

Ghost
L 400 x W 386 x H 1106mm
\$2,495 (Stainless Steel) \$2,995 (Black)
(includes AB3 Burner & Accessories)



Igloo
L 978 x W 494 x H 904mm
\$3,995 (includes BK5 Burner & Accessories)

2 Select a finish

Choose from our commercial-grade concrete which is extremely durable yet incredibly lightweight or our FSC Certified Teak finish, made of the strongest and most durable hardwood available.

*Teak not available for Ark 40, Mix, Nova & Pod Series.

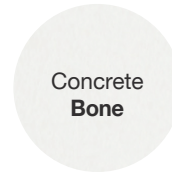
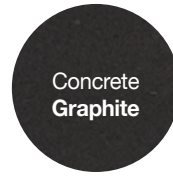

3 Select application

Our Fire Pits and Fire Tables are suitable for use both indoors and outdoors but are pre-assembled for Outdoor Use.

If you're wanting to use it indoors additional parts are required - make sure you know where you wish to use the product as this is important to inform at the time of purchase.



Indoor



Outdoor

Included accessories



Jerry Can, Safety Spout & e-NRG bottle adapter



Lighting Rod & Lighter



Black Glass Charcoal (Concrete & Teak models only)



XL Baffles (XL Burner compatible models only)



Efficiency Ring (AB8 compatible models only)



Jerry Can Spout Extension (AB3 compatible models only)

Optional accessories



Glass Fire Screens

Optional Fire Screens help to minimise the impact of wind on the flame and reduce fuel consumption.

- \$495 Wharf 65, Cosmo 50 (L1080)
- \$395 Base 40, Base 30, Manhattan 50 (S500)
- \$395 Ark 40, Martini 50, Pod 40, Pod 30 (R530)
- \$155 Ghost
- \$895 Igloo (Plasma)

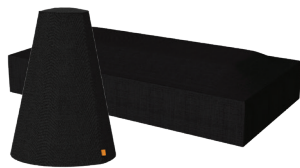

Protective Covers

Made from stain resistant, water resistant material these custom covers are an optional accessory to protect your product for years to come.

- \$195 Wharf 65
- \$175 Ark 40
- \$155 Base 40, Base 30
- \$135 Cosmo 50, Manhattan 50, Martini 50, Pod 40, Pod 30 Stix 8
- \$400 Gin 90 Bar
- \$350 Gin 90 Dining
- \$300 Gin 90 Chat
- \$250 Gin 90 Low
- \$125 Mix 850, Nova 850, Stix
- \$95 Mix 600, Nova 600
- \$75 Mini T, Tank

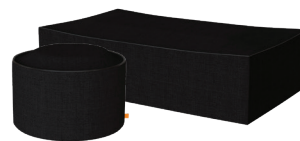

Winter Storage Bags

Water proofed all weather fabric, resists shrinkage, fading, UV rays, and harsh weather. With anti stain coating for easy cleaning.

- \$450 Wharf 65
- \$295 Ark 40, Base 40, Cosmo 50, Manhattan 50, Martini 50, Mix 850, Nova 850 Pod 40
- \$225 Base 30, Mix 600, Nova 600
- \$895 Gin 90 Bar
- \$795 Gin 90 Dining
- \$695 Gin 90 Chat
- \$595 Gin 90 Low
- \$175 Pod 30
- \$125 Tank



Tank

Tank functions as a side table, or stool. Available in Concrete (Natural, Graphite and Bone colours) and Teak (Natural - oiled) finish.

- \$495 Tank Concrete and Teak

Proudly distributed by



spaworld.com.au

Delivery is not included.