

K-5 Bed Rail Caps

Install and prefit before Paint and final assembly A professional is recomened for all TMI Products installs

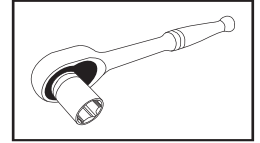

Tools needed:
1. Drill
2. Ratchet

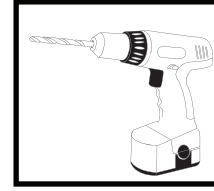

SOCKET

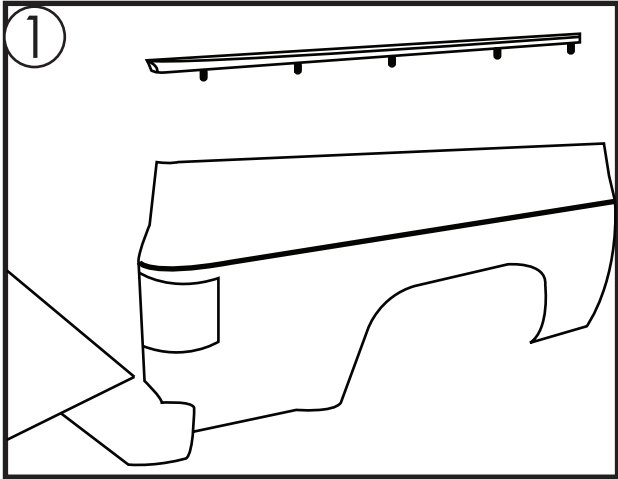

Step 1: First, is to set the side rails onto the bed. The side rails will fit into the factory removable cab holes. once the posts are in you can install the nuts to the bed rail cap studs, this process is very similar to how the factory cab installed. This will be repeated on the opposite side. DO NOT fully tighten these nuts yet as there will be adjustment later.

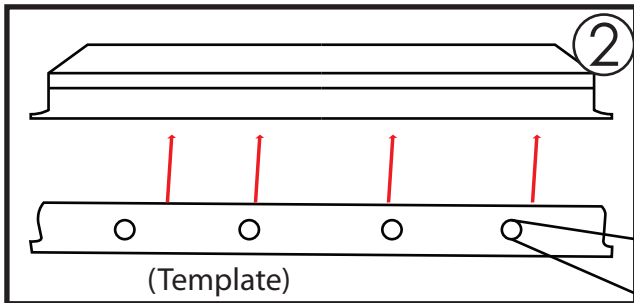

Step 2: Using the drilling template provided. You will mark the location for the drill holes onto the top of the tailgate. Once marked you will drill the four (4) holes out with a / sized drill bit. (NOTE: Diagram 2 is of the tailgate folded down.)

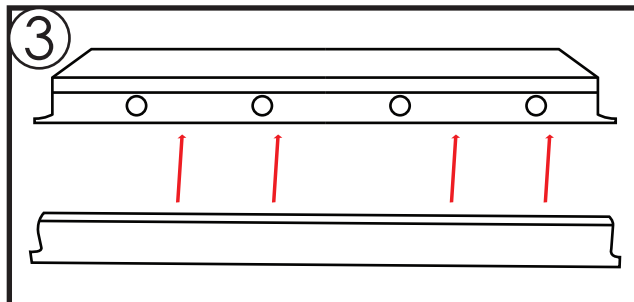

Step 3: Once the holes are drilled into the tailgate you can fasten the tailgate cap down. You will start by tightening the nuts down by hand then using a ratchet with an extension you will fasten it almost all the way down. Leaving enough room for adjustment.

Step 4: Once both the side caps and the tail gate cap are lossely fitted close the tailgate carfully and adjust each part until they fit as desired. once they all fit as desired you can tighten them all down into final postion.