

## 1968-69 Chevelle Molded Door Panel Installation



### PARTS:

### TOOLS NEEDED FOR INSTALL:

1. Scissors
2. Marker
3. Drill

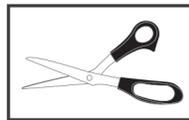

SCISSORS



MARKER

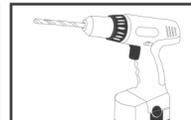

DRILL

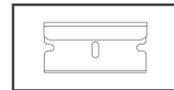

RAZOR BLADE



Door Handle Cup

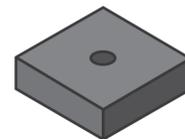

Aluminum Spacer



Screws

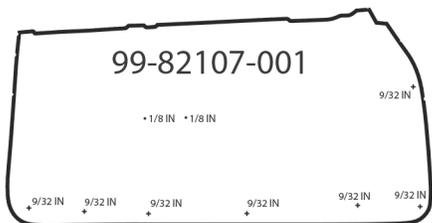

Template

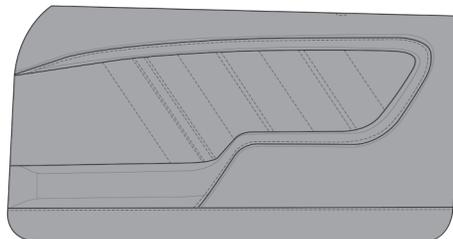

68-72 Chevelle Molded Door Panel

STEP 1. Remove the factory door panels including all the hardware.

NOTE: Some existing hardware will be installed into the new door panel.

STEP 2. Cut out the provided template following the scissors as well as all the labeled holes/openings. Align the template to the factory window crank and holes. Use a marker to mark the holes for drilling.

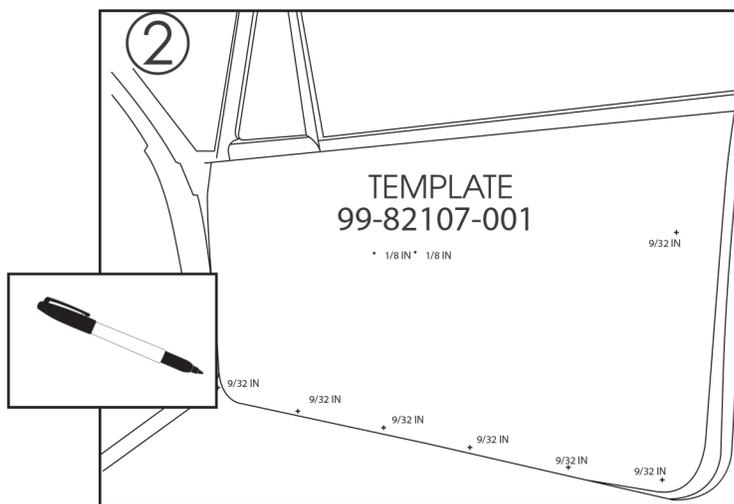
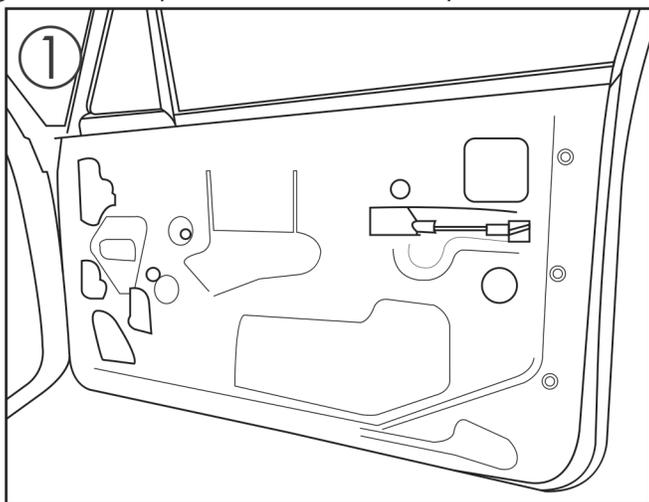

STEP 3. Drill out the marked holes using the sizes indicated on the template.

STEP 4. Line up the aluminum spacer with the drill holes and drill the cup kit bracket through the spacer to the door.

NOTE: Bending the bracket to properly fit the door panel may be needed.

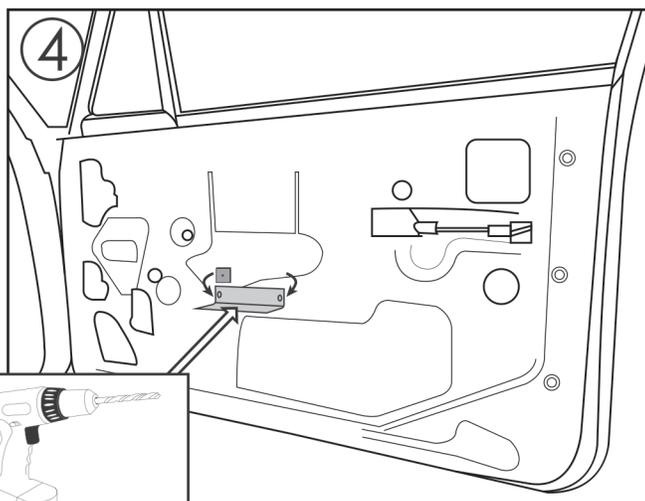
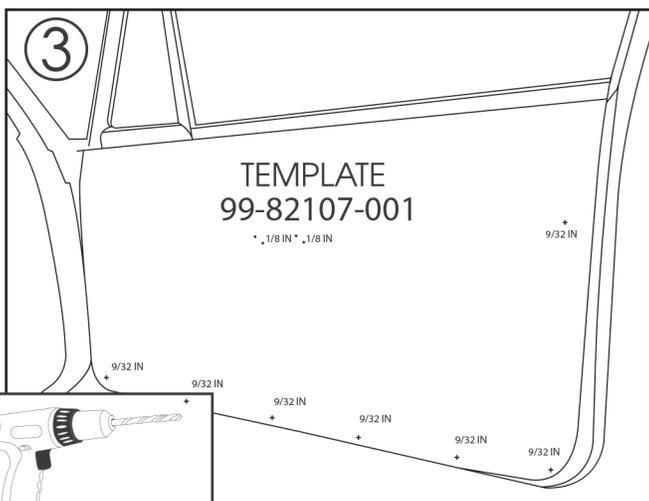

STEP 5. Mount the door panel to the door making sure to align the clips to the holes.

STEP 6. Once mounted, install the door panel cup to the bracket using the screws provided in the kit.

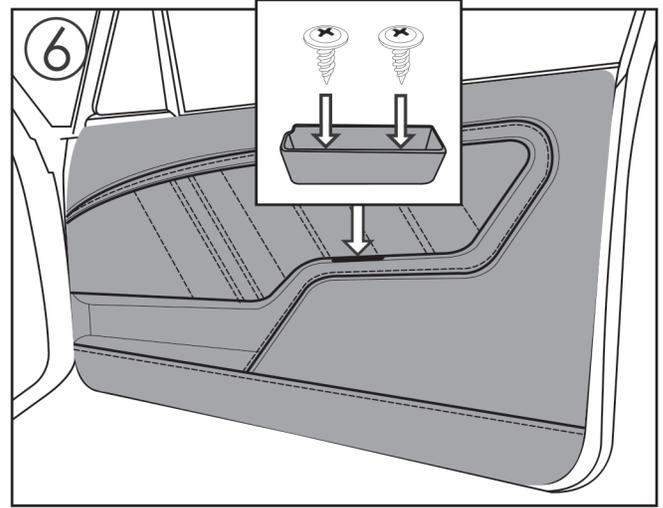
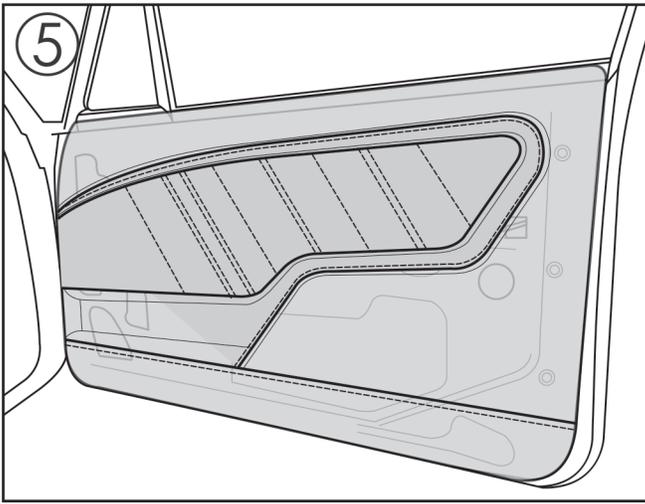

STEP 7. Cut out the material for the window and door crank.

STEP 8. Then install window and door crank. Install Complete.

