

NZXT

N7 Z690

INTEL Z690 ATX MOTHERBOARD

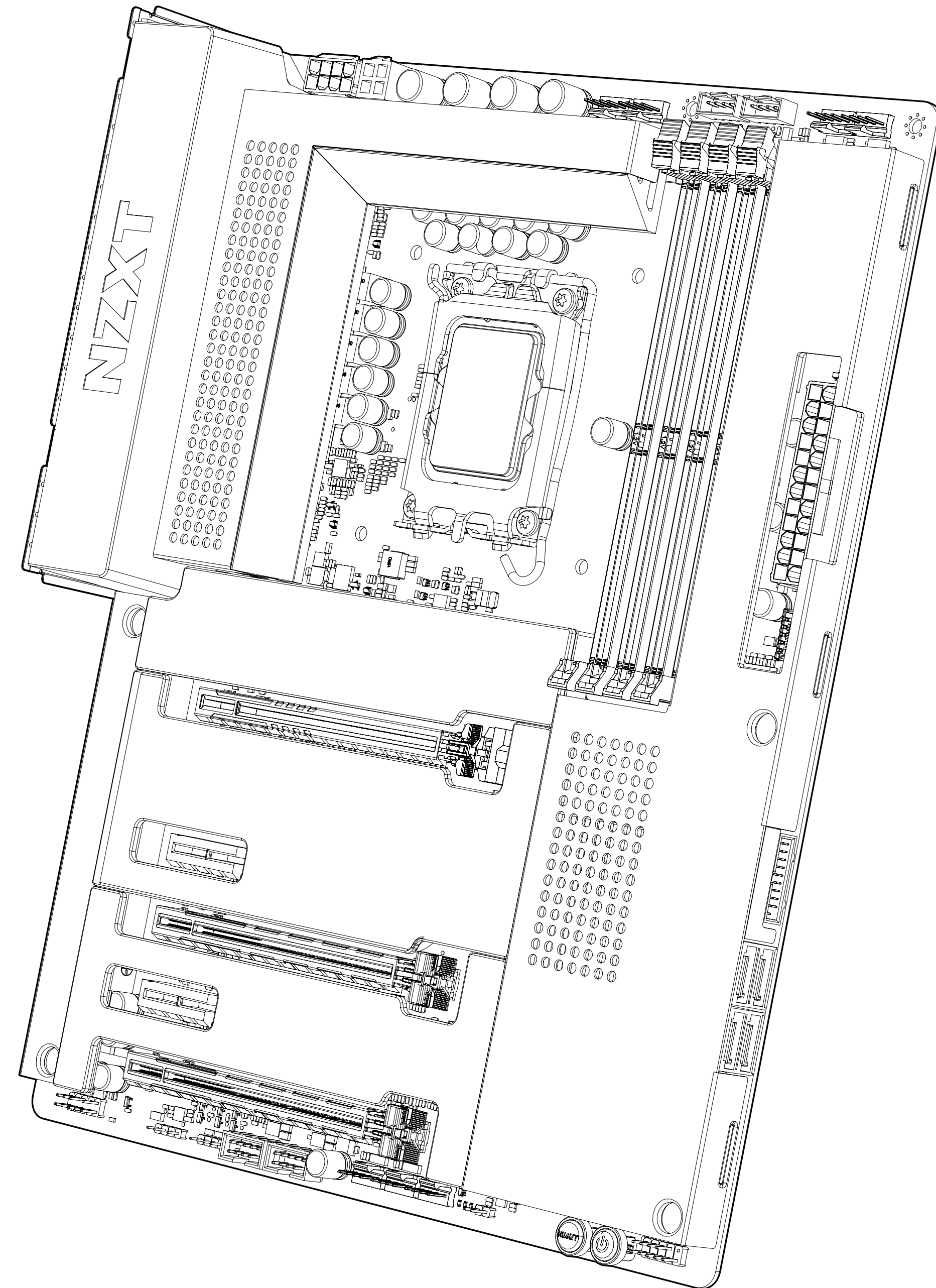

1. PREFÁCIO 02

2. INFORMAÇÕES DO PRODUTO 03

3. COMPONENTES E PORTAS 09-11

4. DOWNLOAD DO NZXT CAM 40

5. APÊNDICE A-1



A. Copyright© NZXT, Inc. Todos os direitos reservados.

Este manual, incluindo todas as ilustrações e capturas de ecrã, são protegido sob leis de direitos autorais internacionais, com todos os direitos reservados. Nem este manual nem qualquer material contido nele pode ser reproduzido sem consentimento por escrito do autor.

B. Isenção de responsabilidade

As informações neste documento estão sujeitas a alterações sem aviso. O fabricante não faz nenhuma declaração nem oferece garantias com relação aos conteúdos do mesmo e especificamente isenta-se de responsabilidade por garantias implícitas de comerciabilidade ou adequação a qualquer propósito em particular. O fabricante reserva-se o direito de revisar esta publicação para fazer alterações de tempos em tempos no conteúdo da mesma sem obrigação de notificar qualquer pessoa sobre tais revisões ou alterações. ai contenuti senza obbligo di segnalare tali revisioni o modifiché.

C. Reconhecimento de marca comercial

Os nomes de produto usados neste manual pertencem aos respectivos proprietários e são reconhecidos.

D. Precaução de segurança

Siga estas precauções de segurança ao instalar a placa-mãe:

- É recomendado utilizar um cabo com ligação a um dispositivo com terra para evitar danos causados por eletricidade estática.
- Descarregue a eletricidade estática tocando na estrutura de metal de um objeto com ligação terra seguro antes de trabalhar na placa-mãe.
- Deixe os componentes em sacos à prova de estática.
- Sempre remova a alimentação CA desligando o cabo de energia da tomada antes de instalar ou remover a placa-mãe ou outros componentes.

2. INFORMAÇÕES DO PRODUTO

N7 Z690 INTEL ATX MOTHERBOARD



2.1 Conteúdo do pacote04

2.2 Especificações.....05

2.1 CONTEÚDO DO PACOTE

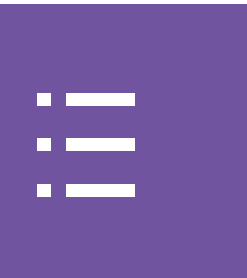

A. Placa-mãe N7 Z690

x1

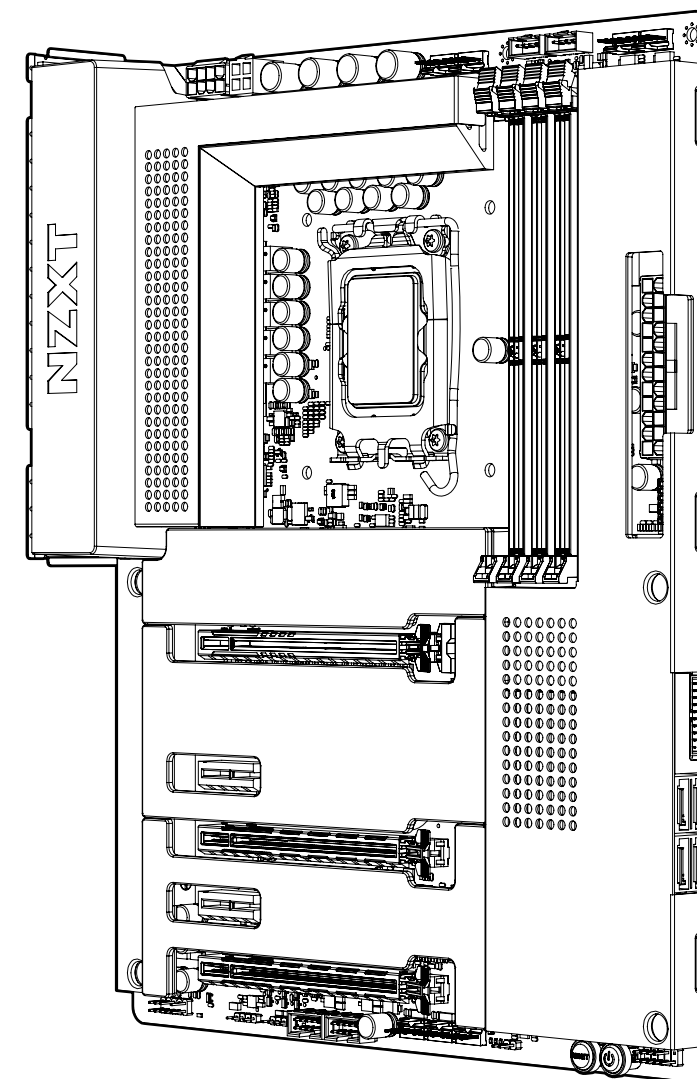

B. CABOS SATA

90°x2, 180°x2

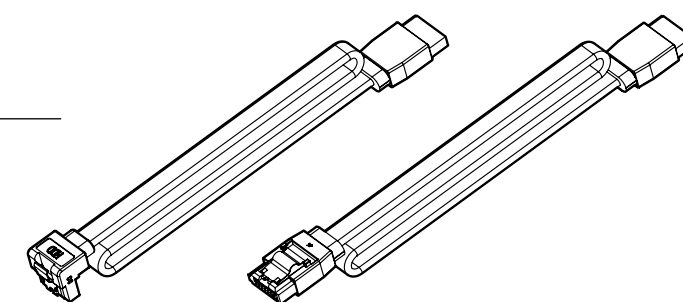

C. Parafusos M.2

x2

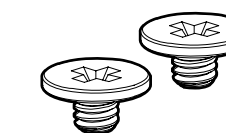

D. Antena sem fio

x2

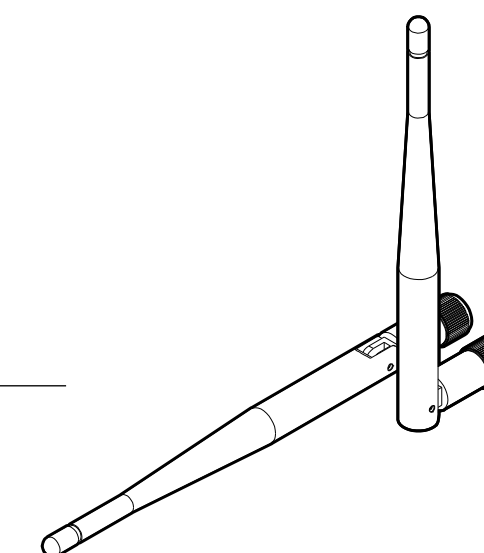



CPU e Encaixes

Encaixe LGA 1700 para Processadores Intel® Core™ 12.^a geração i9/ Core™ i7/ Core™ i5

- Suporta a tecnologia Intel® Hybrid
- Suporta a tecnologia Intel® Turbo Boost Max 3.0

Chipset

Intel® Z690

Memória

4 x Ranhuras DIMM, Máx. 128GB, Tecnologia de memória de canal duplo DDR4

- Suporta memória DDR4, não-ECC, sem buffer, até 4800+ (OC)*
- Suporta memória ECC UDIMM (opera em modo não-ECC)
- Suporta Intel® Extreme Memory Profile (XMP) 2.0

* Suporte nativo de DDR4 3200

* Consulte o Memory QVL no site da NZXT (www.nzxt.com) para obter mais informações.

Gráficos integrados

Processador gráfico integrado - Suporte Intel® UHD Graphics*

- Intel® Xe Graphics Architecture (Ger 12)
- Suporta HDMI™ 2.1 TMDS Compatível com a resolução máx. até 4K x 2K (4096x2160) @ 60Hz
- Suporta HDCP 2.3 com a porta HDMI 2.1

* Suportado apenas com processadores com GPU integrada



Armazenamento

Chipset Intel® Z690

- 1 x M.2_1 Tipo 2242/2260/2280 (modo PCIe Ger 4 x4)*
- 1 x M.2_2 Tipo 2242/2260/2280/22110 (modo PCIe Ger 4 x4)*
- 1 x M.2_3 Tipo 2242/2260/2280 (modo PCIe Ger 4 x4 e SATA 6Gb/s)*
- 4 x portas SATA 6Gb/s

Suporta RAID 0/1/5/10 para dispositivos de armazenamento SATA

Suporta RAID 0/1/5 para dispositivos de armazenamento M.2 NVMe

- * Suporta Intel® Volume Management Device (VMD)
- * Suporta a tecnologia Intel® Optane
- * Suporta os SSD NVMe como discos de arranque

LAN

LAN Realtek® RTL8125BG 2,5G

Wireless

Wireless de banda dupla Wi-Fi 6E

- Wi-Fi 802.11 a/b/g/n/ax
- Suporta a frequência de banda dupla de 160 MHz 2x2 com extensão para 6GHz*
- Suporta MU-MIMO

* A Wi-Fi 6E (banda dos 6GHz) será suportada pelo Microsoft® Windows® 11 e a disponibilidade poderá variar segundo o país e a região. É necessário um router compatível de 6GHz para a funcionalidade 6E.

Bluetooth

Bluetooth V5.2



Áudio

Codec Realtek® ALC1220

Áudio de alta definição de 8 canais, 32-bit /192KHz DAC

Ranuras de expansão

3 x PCIe × 16 slots*

(Único - PCIe_1: Modo Ger 5 x 16)

(Duplo - PCIe_1: Ger 5 ×16; PCIe_3: Ger 4 ×4)

(Triplo - PCIe_1: Ger 5 ×16 ; PCIe_3: Ger 4 ×4; PCIe_5: Ger 3 ×4)

2 x PCIe Gen 4 × 1 slots

- Suporta AMD Quad CrossFireX™ e CrossFireX™

* Suporta os SSD NVMe como discos de arranque

1 x Encaixe M.2 (Tecla E), suporta o módulo Wi-Fi/BT do tipo 2230, Intel® CNVio

Entrada/saída traseira

- 2 x Conectores SMA de antena Wireless
- 1 x Porta HDMI™
- 2 x Portas USB 2.0
- 1 x Porta USB 3.2 Ger 2x2 Tipo C
- 2 x Portas USB 3.2 Ger 2
- 3 x Portas USB 3.2 Ger 1
- 1 x Botão para limpar a CMOS
- 1 x Botão de BIOS Flashback
- 1 x Porta LAN (RJ45)
- 1 x Conector áudio de canal 5.1
- 1 x Porta de saída ótica S/PFID



Entrada/saída interna

- 1 x Conector de alimentação ATX de 24 pinos
- 1 x Conector de alimentação de 12 V ATX 8+4 pinos
- 1 x Conector CPU_FAN de 4 pinos (Até 24W por canal)
- 1 x Conector de 4 pinos AIO_PUMP (Até 24W por canal)
- 5 x Conectores de 4 pinos SYS_FAN (Até 24W por canal)
- 2 x Conectores RGB LED NZXT
- 1 x Conector RGB LED 5V endereçável
- 1 x Conector RGB LED 12V
- 2 x Conectores USB 2.0 (até 4 portas USB 2.0)
- 1 x Conector USB 3.2 Ger 1 (até 2 portas USB 3.2 Ger 1)
- 1 x Conector no painel dianteiro USB 3.2 Ger2 (para USB tipo C)
- 1 x Conector áudio no painel dianteiro
- 1 x Botão de energia
- 1 x Botão de reinicialização
- 4 x LEDs POST

Sistema operativo

Microsoft® Windows® 11/10 (64-bit)

Coeficiente de forma

ATX

Requisitos do sistema

O software NZXT CAM requer o sistema operacional Microsoft Windows® 11/10.

O NZXT CAM é gratuito para baixar e usar; alguns recursos exigem um endereço de e-mail válido, aceitação de nossos Termos de Serviço e uma conexão ativa com a Internet.



3.1 Tampas.....12

3.2 Vista expandida13

3.3 Visão geral das portas.....14

3.4 E/S traseira.....15

3.5 Soquete de CPU16

3.6 Entradas DIMM.....18

3.7 Slots de expansão para PCI Express.....20

3.8 Conectores SATA.....22

3.9 Entradas M.2 para armazenamento.....23

3.10 Entrada M.2 para conectividade sem fio25



3.11 Antenna26

3.12 Conectores de energia..... 27

3.13 Conectores USB.....28

3.14 Conector de áudio do painel frontal29

3.15 Conector do painel frontal..... 30

3.16 Conectores do ventilador 31

3.17 Conectores RGB NZXT.....32

3.18 Conector RGB endereçável de 5 V33

3.19 Conector RGB de 12 V.....34

3.20 Botões e LEDs de coluna.....35

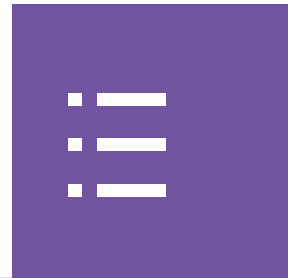

3.21 Bateria CMOS38

3.22 BIOS Flashback39

3.1 TAMPAS

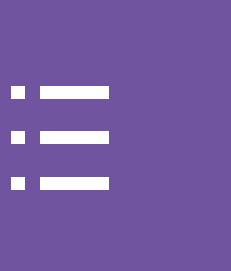

The all-metal N7 cover pieces can be removed by hand. They are latched onto the motherboard through multiple points. When installing and removing, please pay close attention to these points and apply an even force to prevent damage.

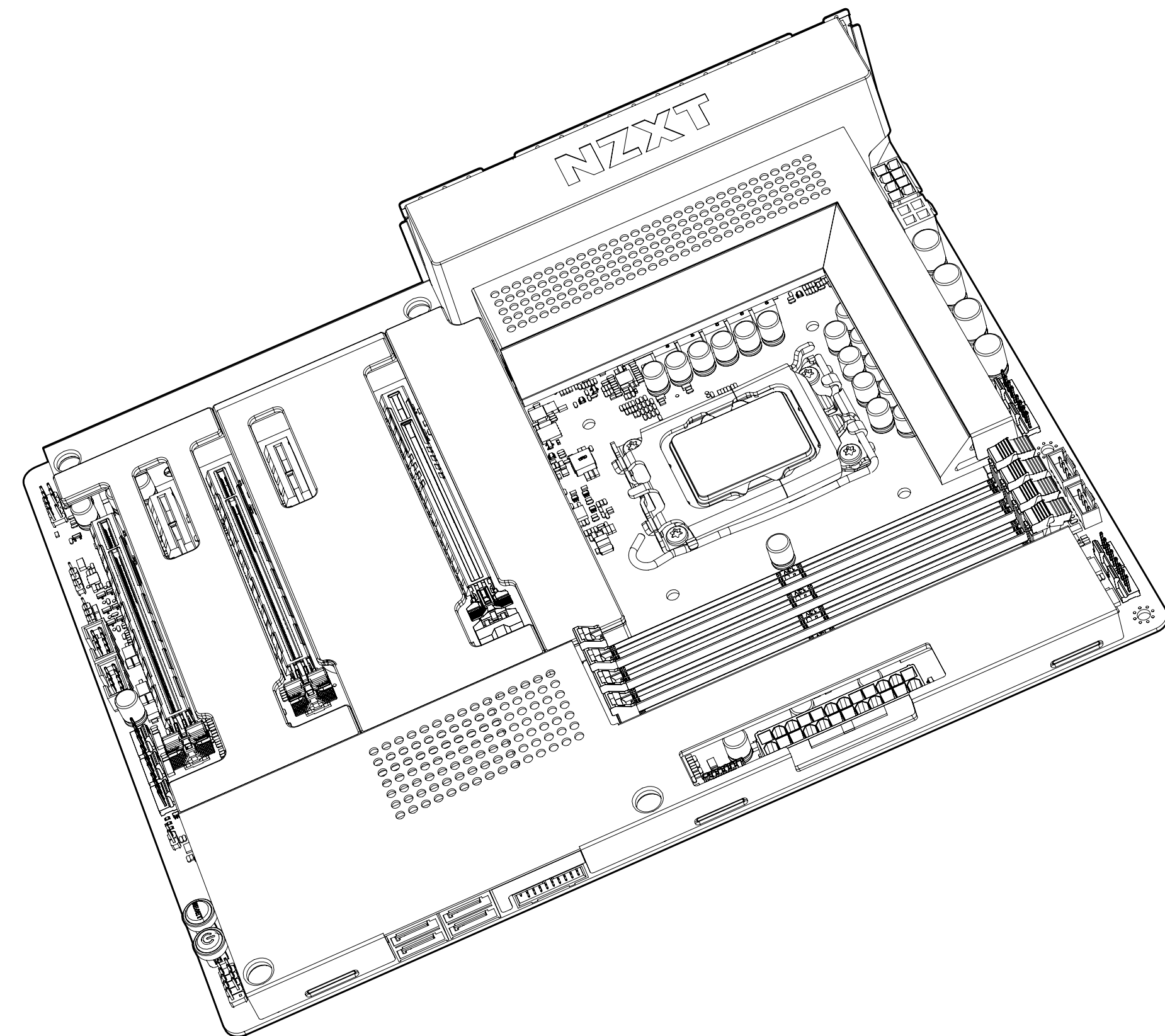

3.2 VISTA EXPANDIDA

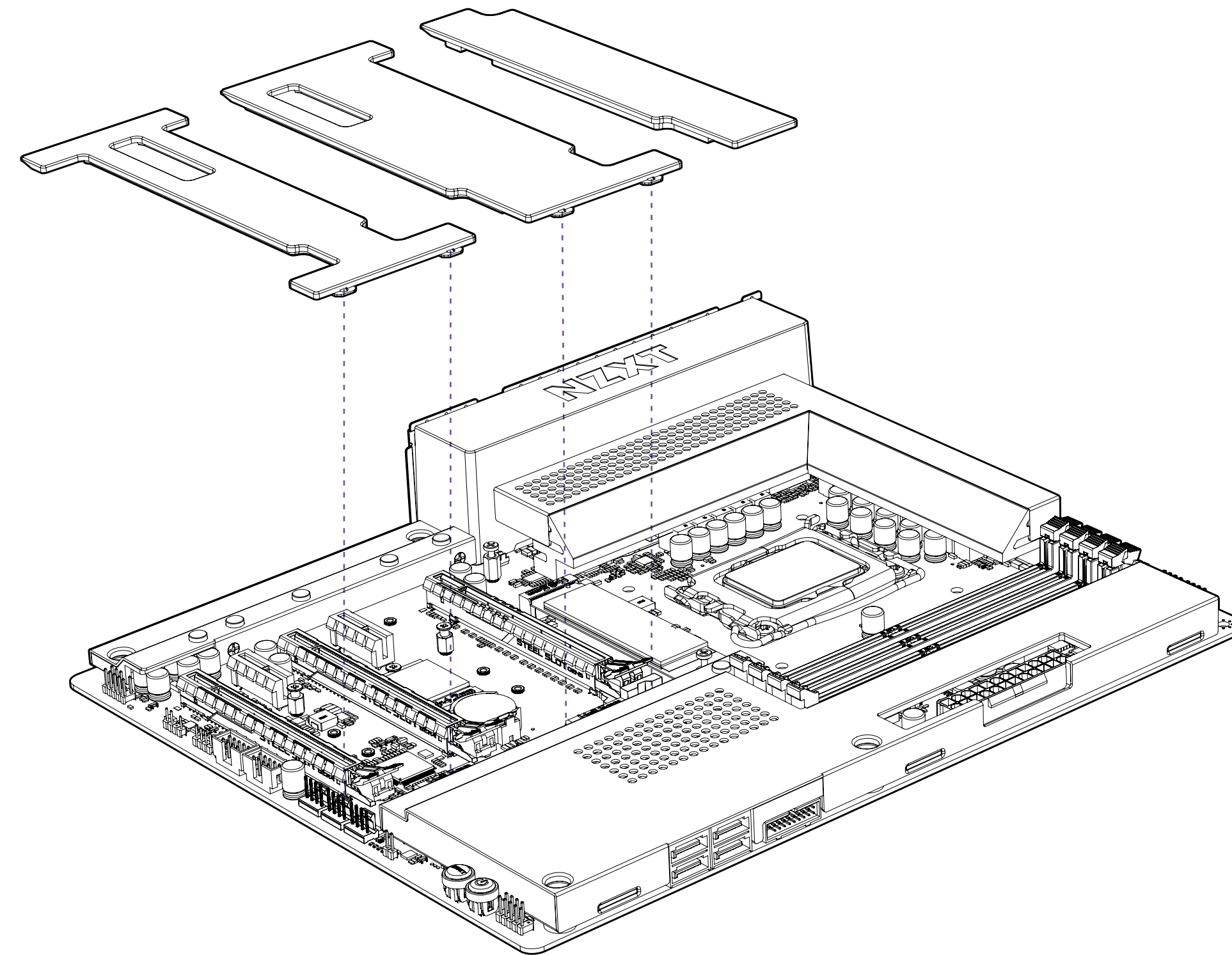

3.3 VISÃO GERAL DAS PORTAS

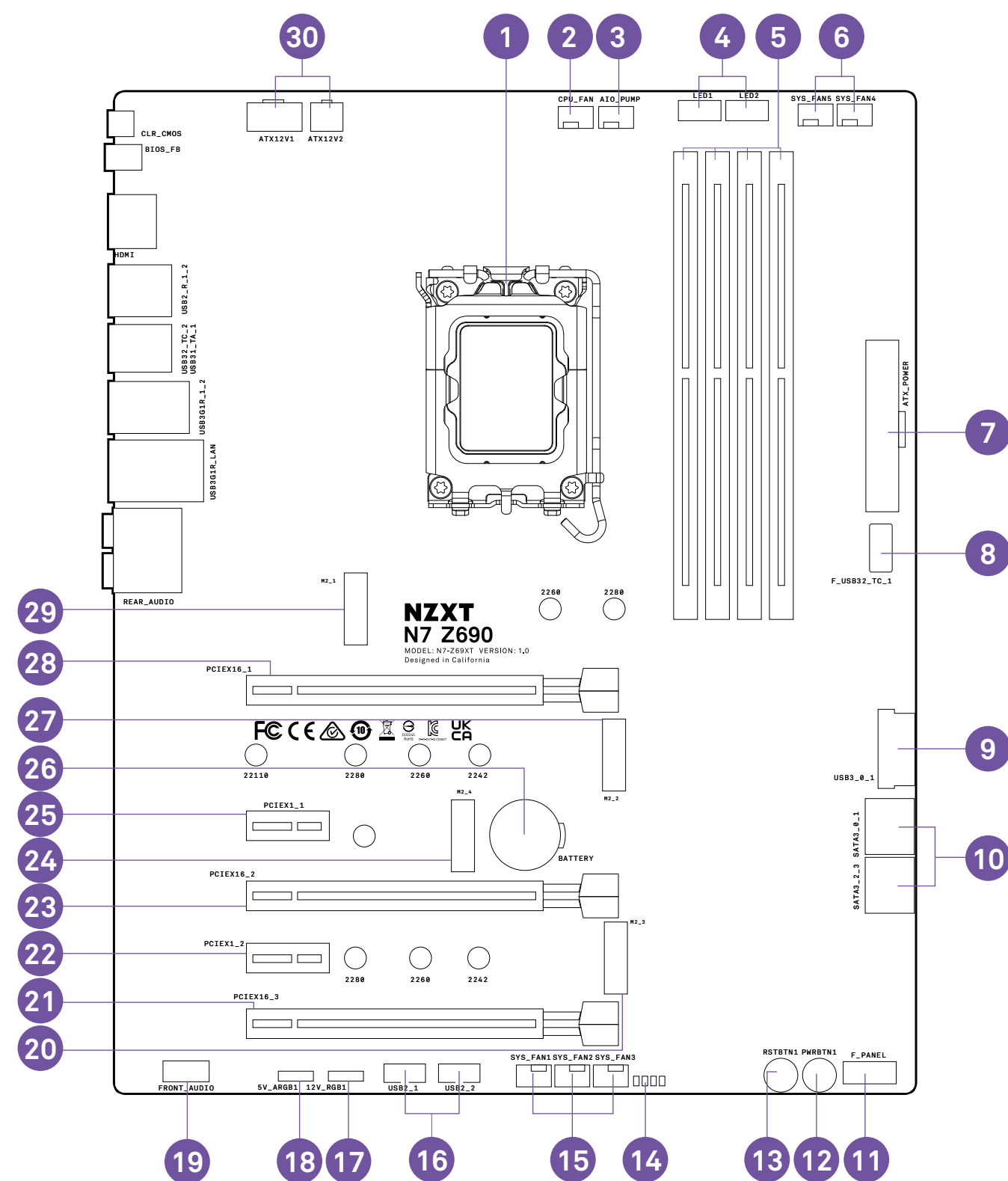
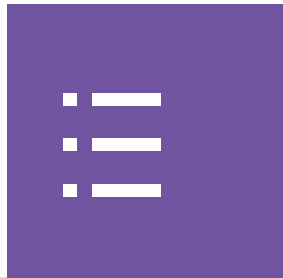

NO.	PORT NAME	DESCRIPTION
1	Soquete de CPU	Soquete LGA 1700 para processador Intel 12ª geração
2	CPU_FAN	Conector de ventilador da CPU de 4 pinos
3	AIO_PUMP	Conector de bomba AIO de 4 pinos
4	NZXT RGB 1 e 2	Cabeçote LED de 4 pinos
5	DIMM A1-B2	Entrada de memória DDR4 de 288 pinos
6	SYS_FAN 4-5	Conectores do ventilador de 4 pinos
7	ATX_POWER	Conector de energia ATX de 24 pinos
8	USB3G2C_1	Cabeçote tipo C USB 3.2 Gen 2 no painel frontal
9	USB3G1_0_1	Cabeçote USB 3.2 Gen 1 no painel frontal
10	SATA 1-4	Conectores seriais ATA 6 Gbps
11	Conectores do painel frontal	Interruptores do painel frontal e conectores LED
12	Botão Liga/Desliga	Botão Liga/Desliga
13	Botão Redefinir	Botão Redefinir
14	LEDs de coluna	Indicador de status de inicialização
15	SYS_FAN 1-3	Conectores do ventilador de 4 pinos

NO.	PORT NAME	DESCRIPTION
16	USB2_1-2	Cabeçotes USB 2.0 no painel frontal
17	12V RGB1	Cabeçote LED 12 V de 4 pinos
18	5V ARGB1	Cabeçote LED 5 V de 3 pinos
19	FRONT_AUDIO	Conector de áudio do painel frontal
20	M2_3	Soquete 3 M.2 com chave M, oferece suporte para dispositivos de armazenamento tipo 2242/2260/2280 (suporte para os modos SATA e PCIe)
21	PCIEX16_3	Entrada para PCI Express x16 Gen3
22	PCIEX1_2	Entrada para PCI Express x1 Gen4
23	PCIEX16_2	Entrada para PCI Express x16 Gen4
24	M2_4	Soquete 1 M.2 com chave E, oferece suporte para dispositivos sem fio tipo 2230 com CNVio
25	PCIEX1_1	Entrada para PCI Express x1 Gen4
26	Bateria	Bateria CMOS
27	M2_2	Soquete 3 M.2 com chave M, oferece suporte para dispositivos de armazenamento tipo 2242/2260/2280/22110 (suporte para PCIe)
28	PCIEX16_1	Entrada para PCI Express x16 Gen5 para GPU
29	M2_1	Soquete 3 M.2 com chave M, oferece suporte para dispositivos de armazenamento tipo 2242/2260/2280 (suporte para PCIe)
30	ATX_12V	Conectores de energia de +12 V de 8+4 pinos

3.4 E/S TRASEIRA

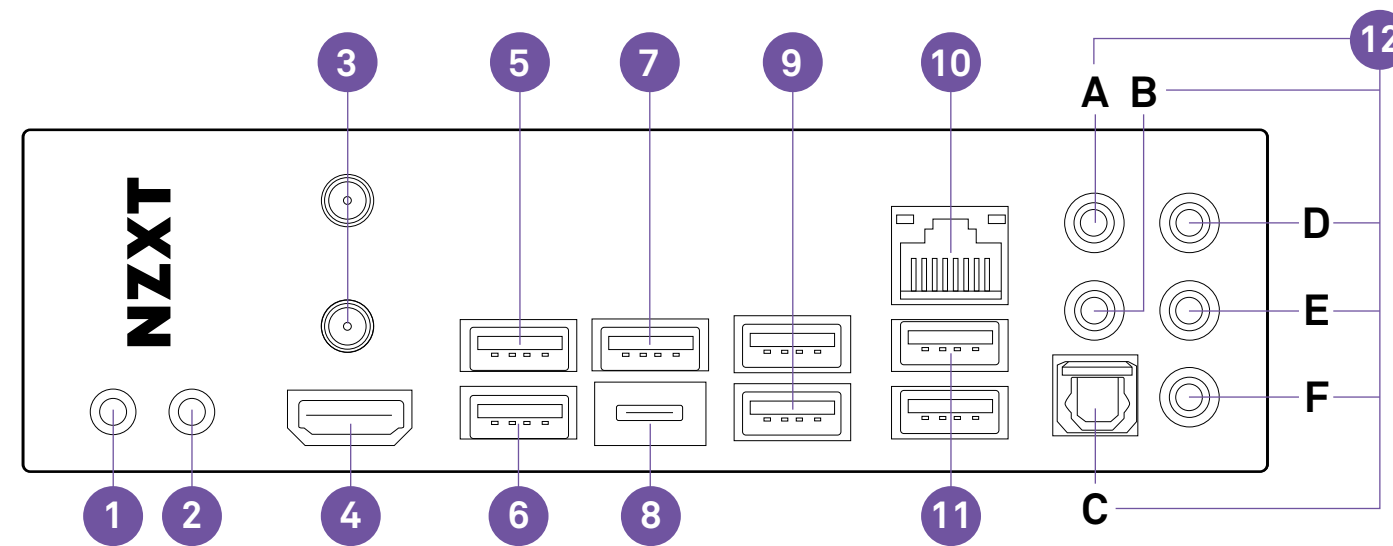

NO.	PORT NAME
1	Botão Limpar CMOS
2	Botão BIOS Flashback
3	Antena sem fio
4	Porta HDMI
5	USB 3.2 Ger 1 com função de BIOS Flashback
6	USB 2.0
7	USB 3.2 Gen 1
8	USB 3.2 Gen 2x2 tipo C

NO.	PORT NAME
9	USB 3.2 Gen 1
10	Porta LAN RJ45
11	USB 3.2 Gen 2
12	Portas de áudio
	A. Central e subwoofer
	B. Surround traseiro
	C. Porta de saída SPDIF óptica
	D. Entrada de linha
	E. Esquerdo e direito dianteiro
	F. Microfone

3.5 SOQUETE DE CPU



A superfície da CPU LGA 1700 tem quatro entalhes e um triângulo dourado para ajudar a alinhar corretamente a CPU para posicionamento no soquete.

OBSERVAÇÃO

- Sempre desconecte o cabo de energia da tomada antes de instalar ou remover a CPU.
- Guarde a tampa protetora da CPU depois de instalar a CPU.
- Confirme que o dissipador de calor da CPU esteja bem montado antes da inicialização.
- Sempre que a CPU não estiver instalada, proteja os pinos do soquete da CPU cobrindo o soquete com a tampa plástica protetora.
- Consulte as instruções do fabricante do resfriador da CPU para instalá-lo.

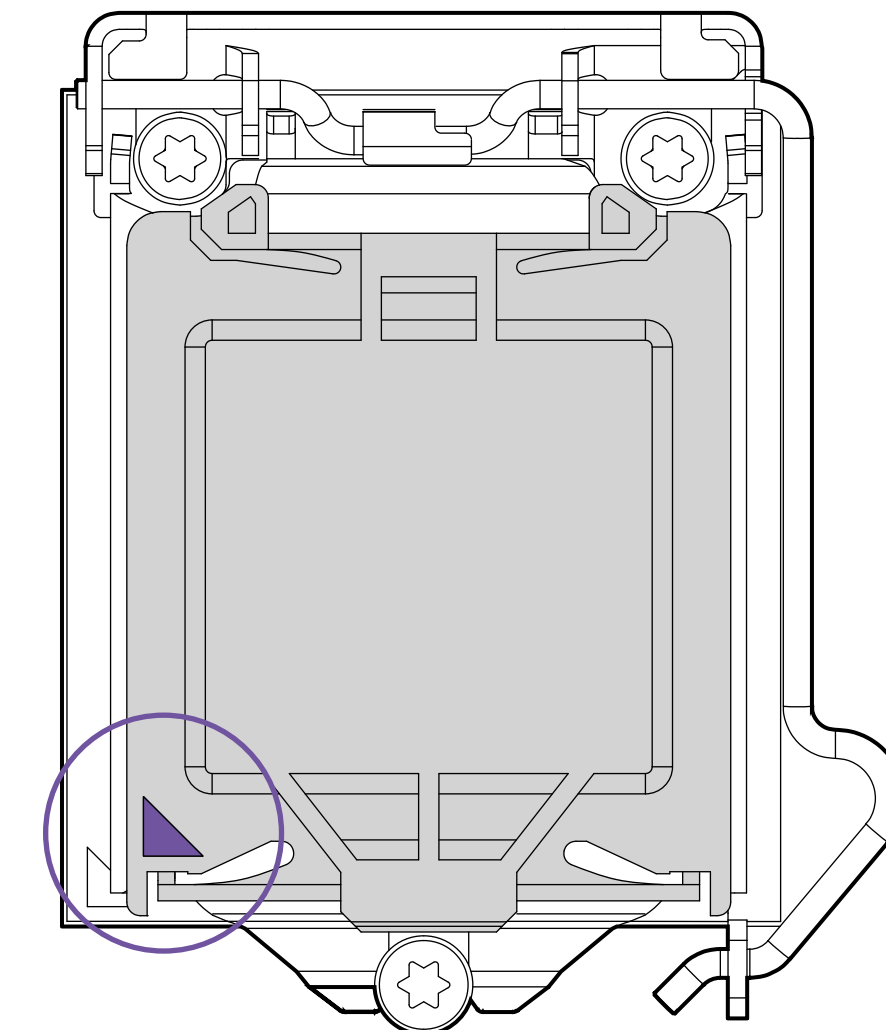
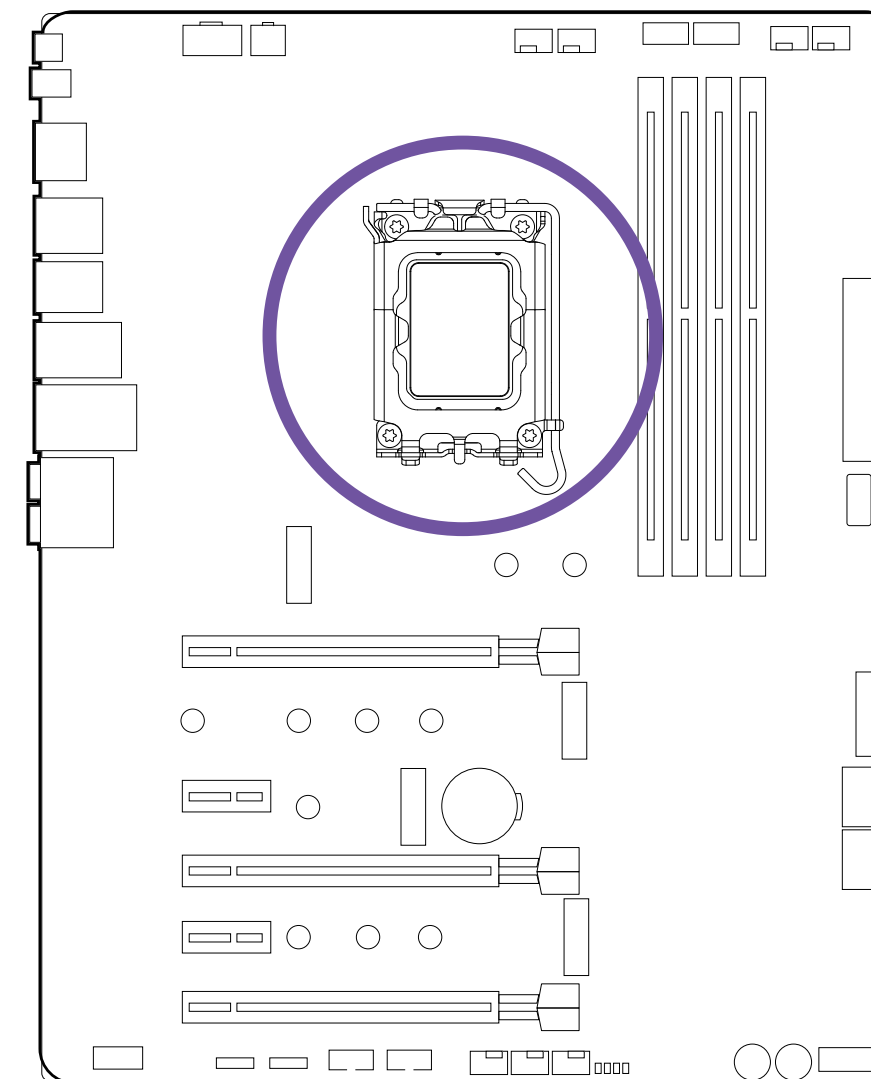

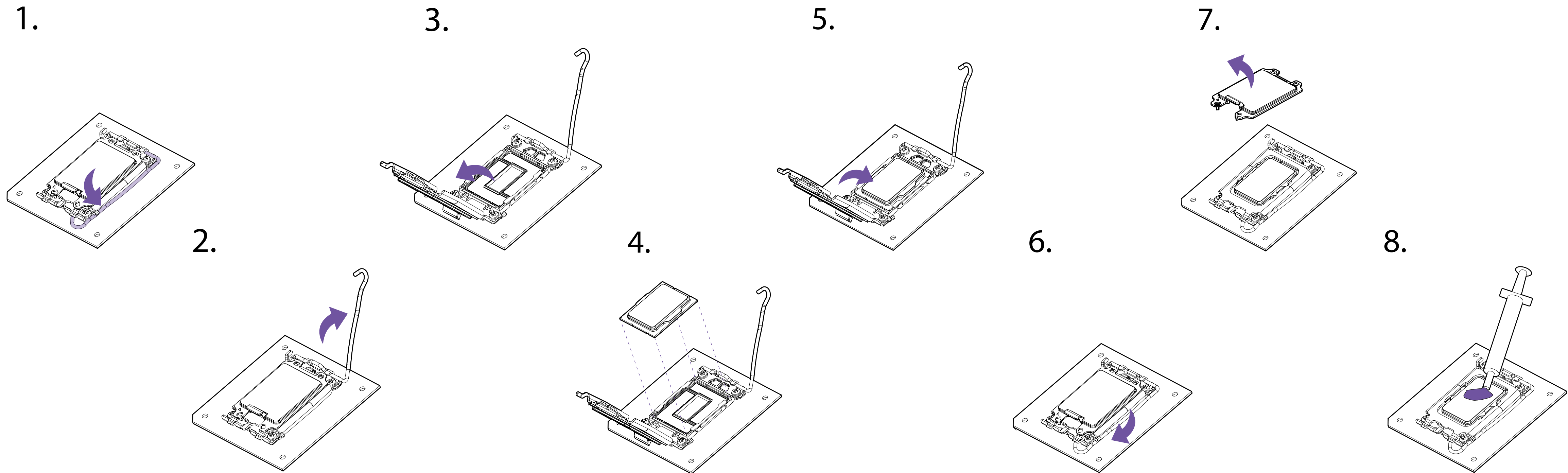

- Pressione o braço de retenção para baixo e para fora para soltar.
- Abra a trava e posicione a CPU garantindo que o triângulo e os entalhes na CPU combinem com o canto conforme indicado.
- Feche a trava e empurre o braço de retenção para baixo para travá-la no lugar.
- A tampa plástica protetora se soltará automaticamente.
- Aplique pasta térmica conforme necessário e instale o resfriador de CPU.

3.6 ENTRADAS DIMM



As entradas DIMM estão localizadas aqui. Consulte o diagrama para a configuração de memória recomendada.

OBSERVAÇÃO

- Insira os módulos de memória na entrada A2 primeiro.

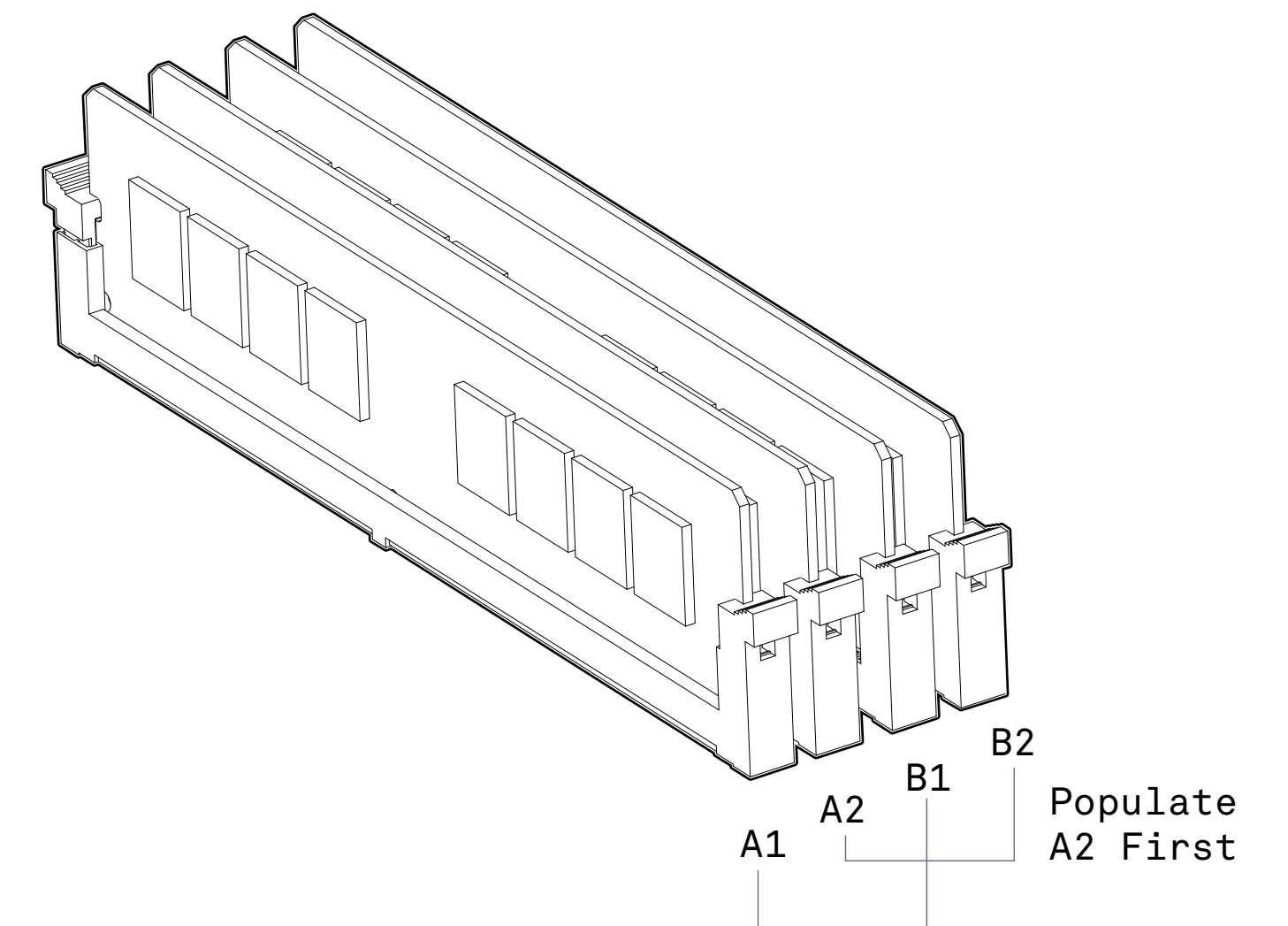
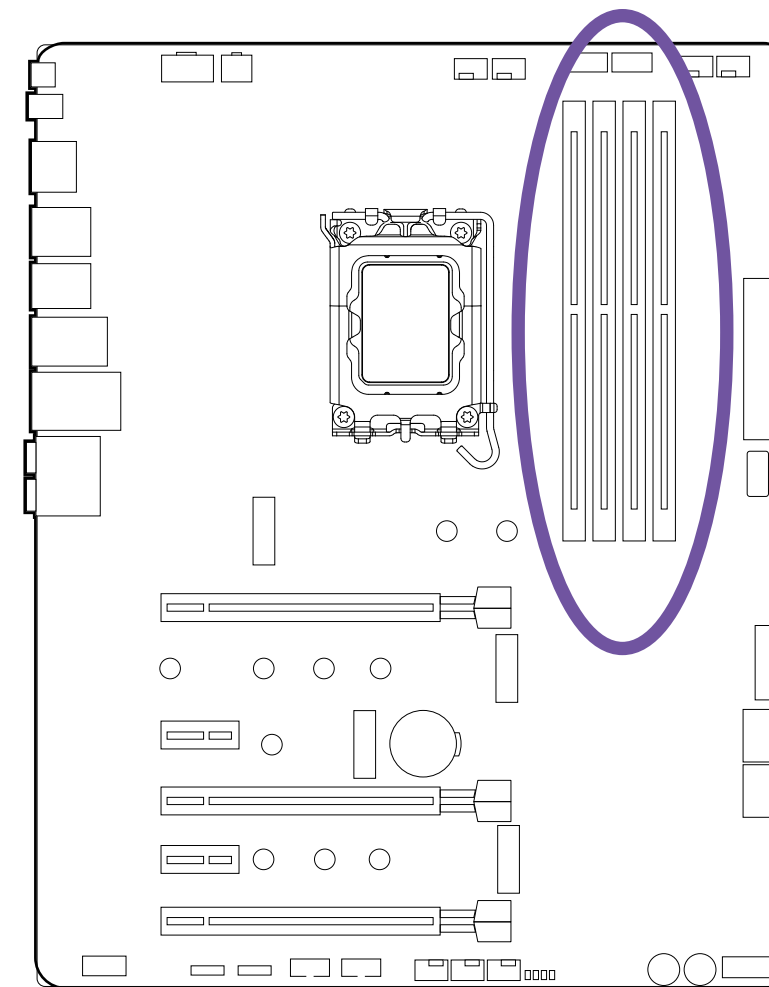

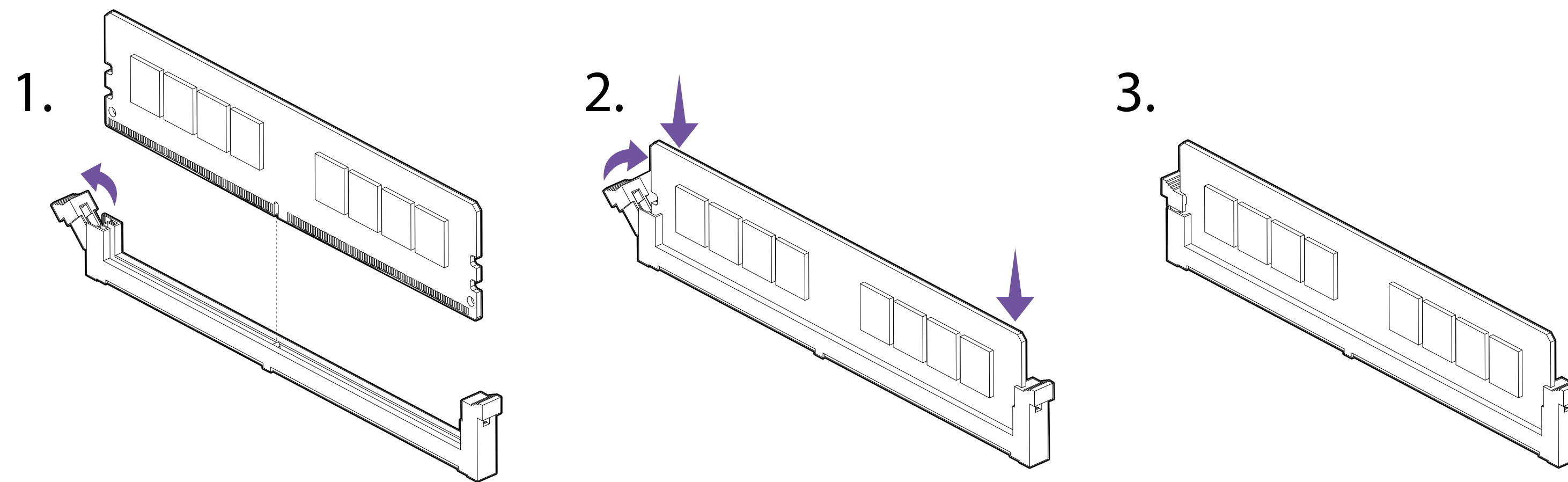
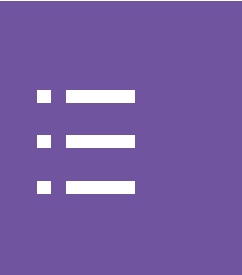

- Pressione a alavanca de liberação como indicado.
- Combine a memória com o entalhe intermediário e alinhe-o às entradas DIMM.
- Empurre a memória para a entrada DIMM firmemente até a alavanca travar automaticamente.

3.7 SLOTS DE EXPANSÃO PARA PCI EXPRESS



Consulte o diagrama abaixo para a lista de entradas. Instale as placas gráficas usando o PCIEX16_1 primeiro e então o PCIEX16_2.

OBSERVAÇÃO

- Para um único PCIe x16, use PCIEX16_1.
- Ao adicionar ou remover placas de expansão, sempre desligue a fonte de alimentação e desconecte seu cabo de energia da tomada. Leia a documentação da placa de expansão para verificar se são necessárias alterações de hardware ou software adicionais.

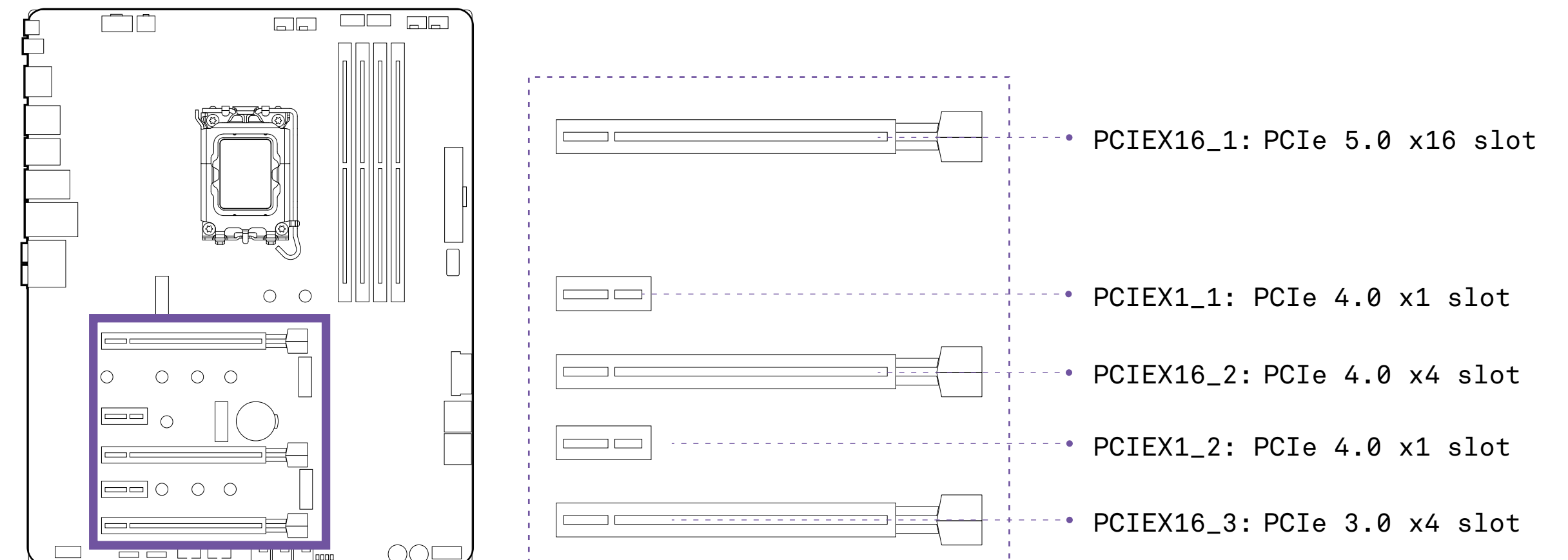



Para recomendações de fonte de alimentação para configurações de várias GPU, consulte o guia do usuário da sua placa gráfica para garantir que você cumpra todos os requisitos do sistema.

Para instalar várias placas gráficas:

- Desligue o computador e desconecte o cabo de energia, instale duas placas gráficas nas entradas PCIEX16_1 e PCIEX16_2.
- Conecte todos os conectores de energia PCIe das placas gráficas.
- Reconecte o cabo de energia, ligue o computador e instale os drivers e o software inclusos com o pacote da placa gráfica.

3.8 CONECTORES SATA



Esses conectores são portas de interface SATA 6 Gb/s. Cada conector pode conectar-se a um dispositivo SATA. Nenhuma porta utiliza a mesma largura de banda com nenhum M.2.

OBSERVAÇÃO

- Não dobre o cabo SATA a um ângulo de 90 graus. Caso contrário, poderá ocorrer perda de dados durante a transmissão.
- Cabos SATA têm conectores idênticos em ambas as extremidades. Porém, recomendamos conectar o conector chato à placa-mãe para economizar espaço.

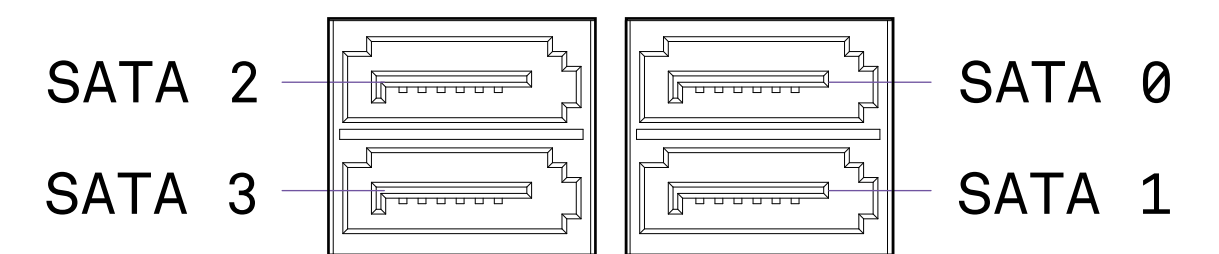
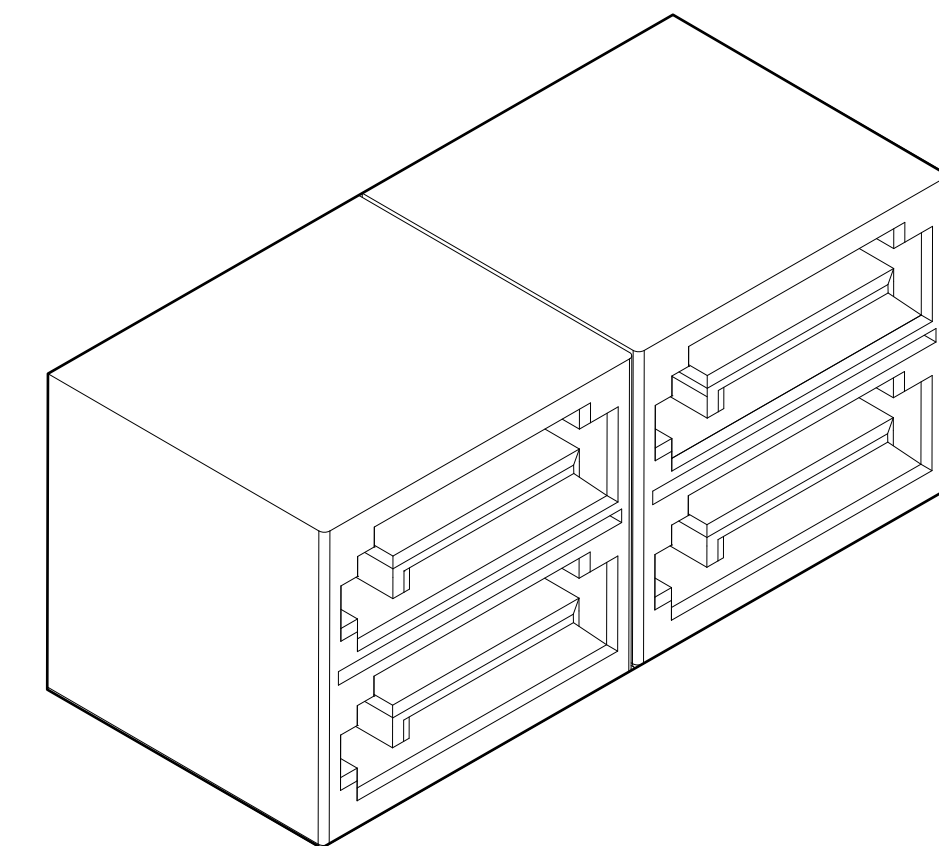
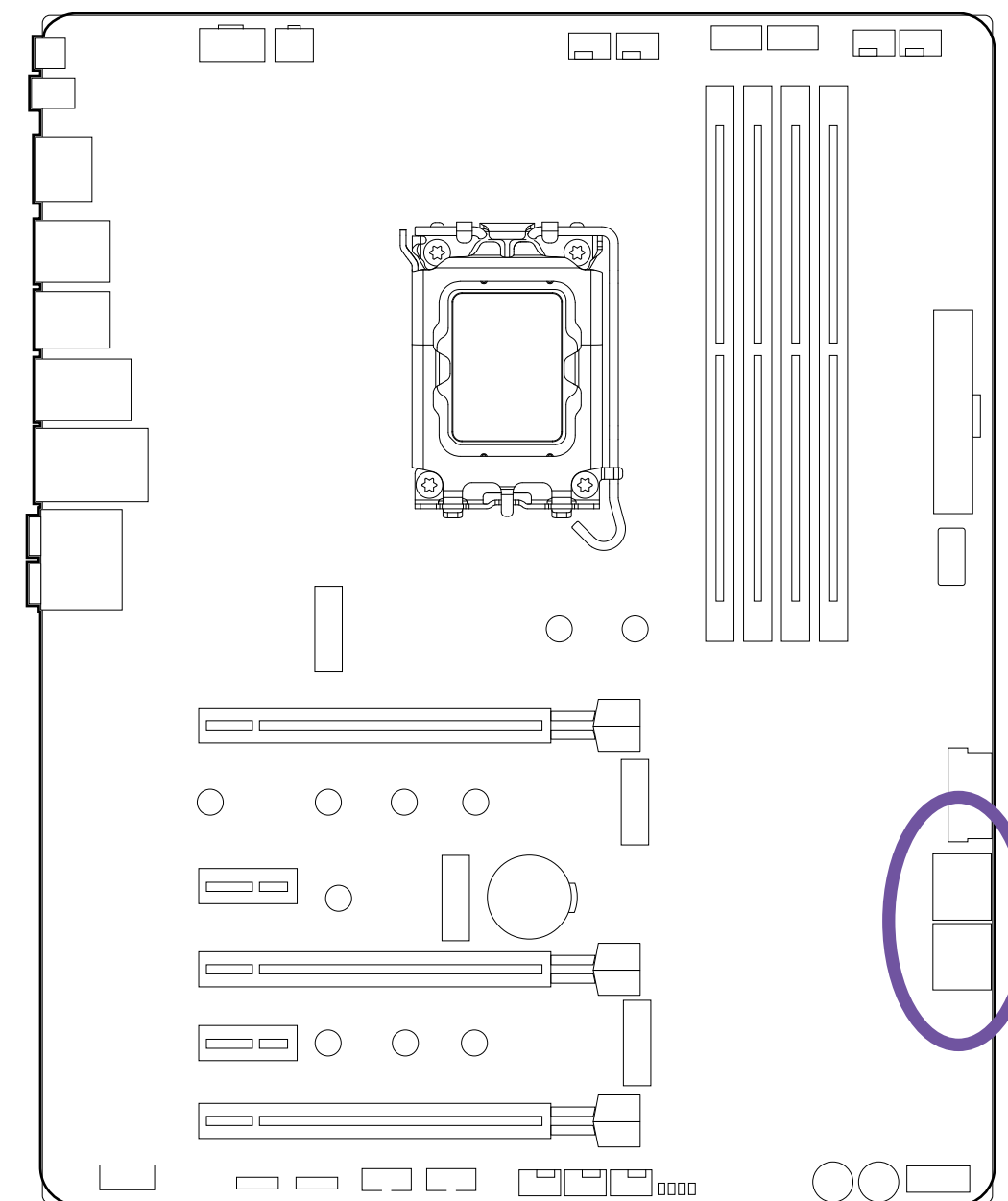



Há quatro ranhuras M.2 na motherboard N7. Terá de remover as peças de cobertura em aço antes da instalação. A ranhura de cima inclui um dissipador de calor. Por favor, siga as instruções abaixo para instalar a sua drive M.2.

OBSERVAÇÃO

- Suporta Intel® Volume Management Device, tecnologia de memória Intel® Optane e SSD NVMe como discos de arranque.

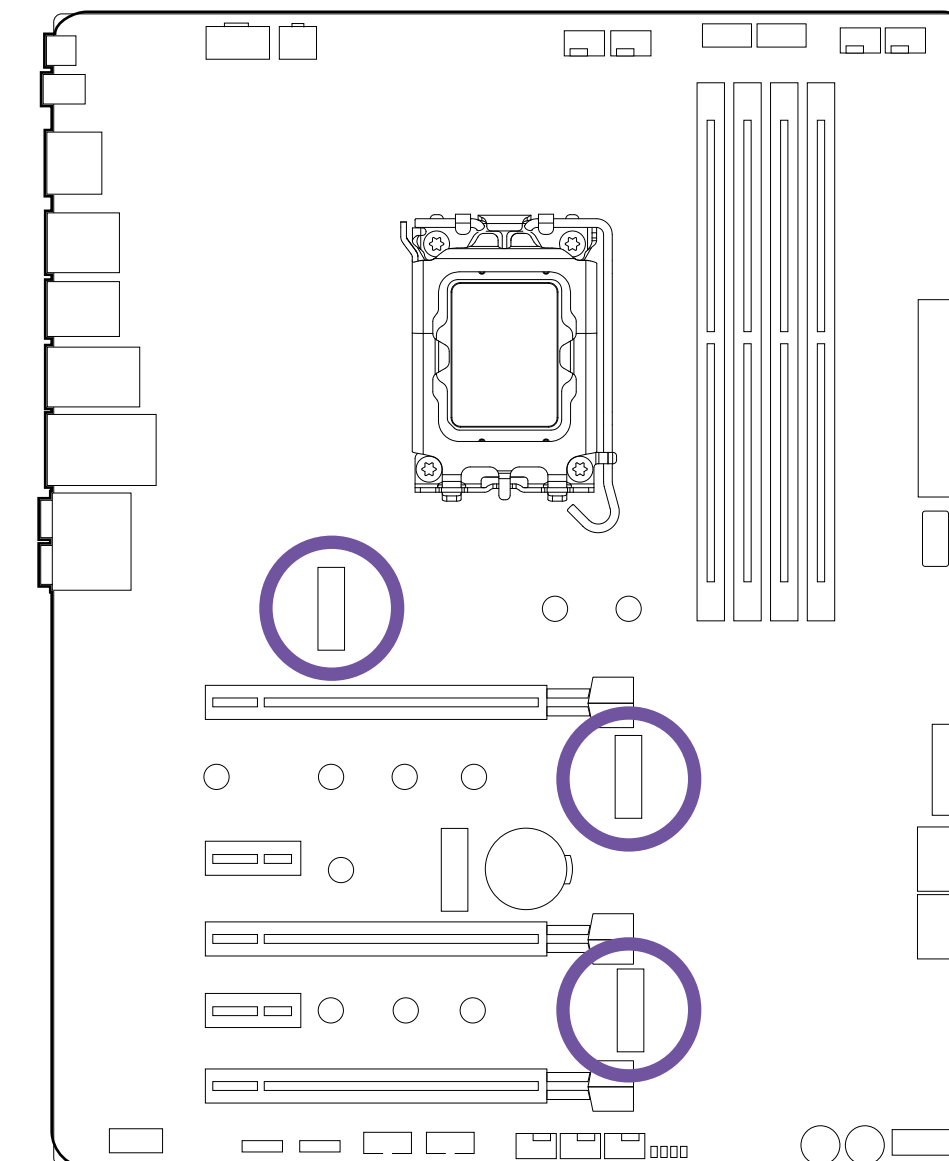

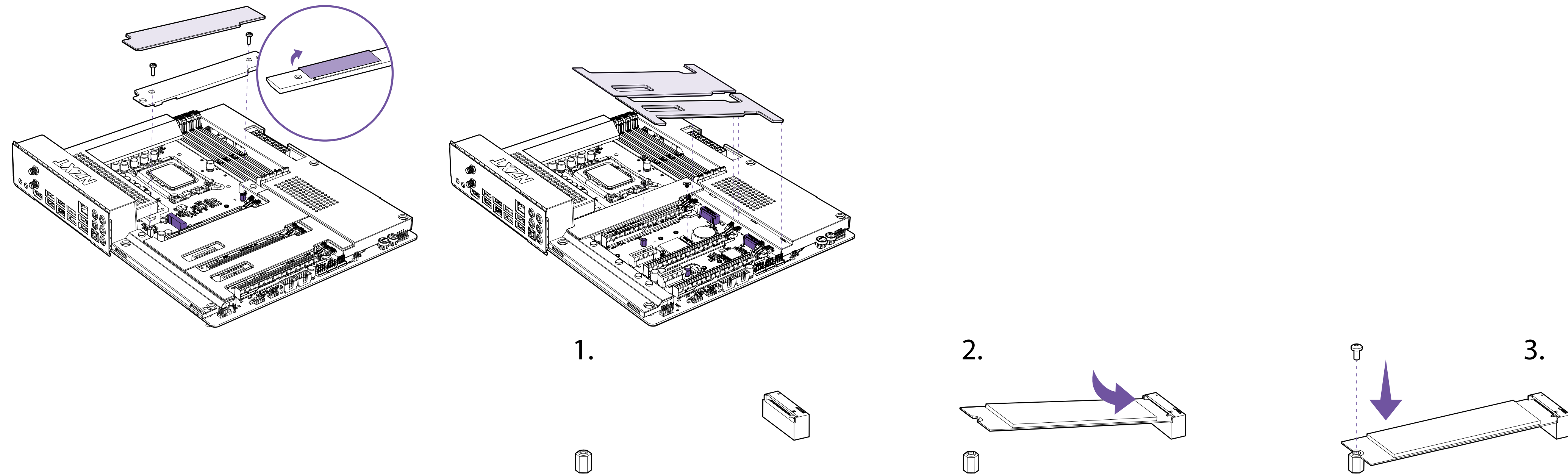

- Remova a tampa da entrada M.2.
- Confirme que o afastamento está na posição correta e, se necessário, mova-o.
- Insira seu inversor M.2 na entrada M.2 a um ângulo.
- Prenda o inversor M.2 usando o parafuso M.2 no afastamento e aperte.

3.10 ENTRADA M.2 PARA CONECTIVIDADE SEM FIO



No centro da motherboard, existe uma ranhura M.2 de Tecla E que suporta o PCIe e o CNVio. Esta ranhura está pré-populada com um cartão wireless e dois cabos de antena enviam os sinais wireless para a entrada/saída traseira.

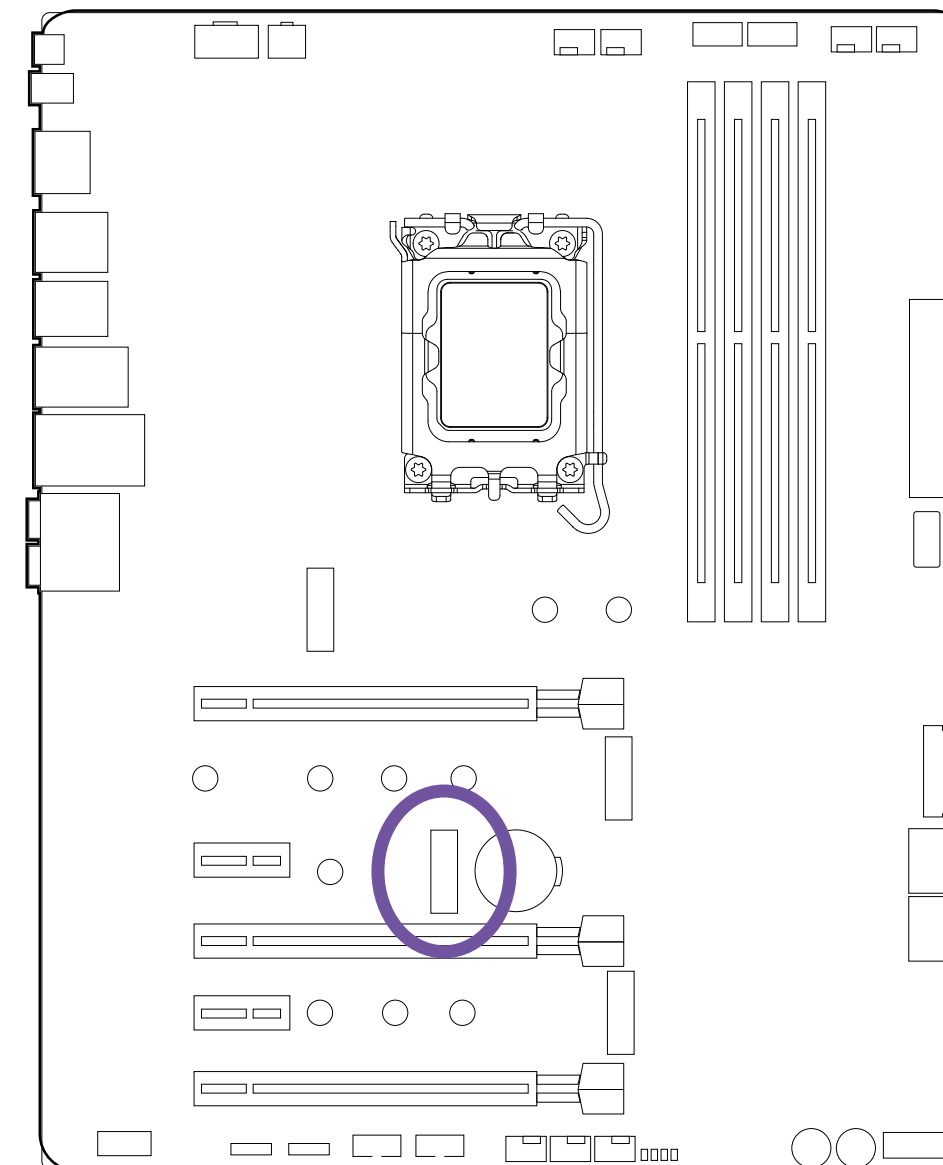

3.11 ANTENA



Antenas sem fio inclusas para impulsionar os sinais sem fio e Bluetooth.

- Conecte a antena na E/S traseira fixando-a diretamente às portas SMA rotuladas como "Wi-Fi".

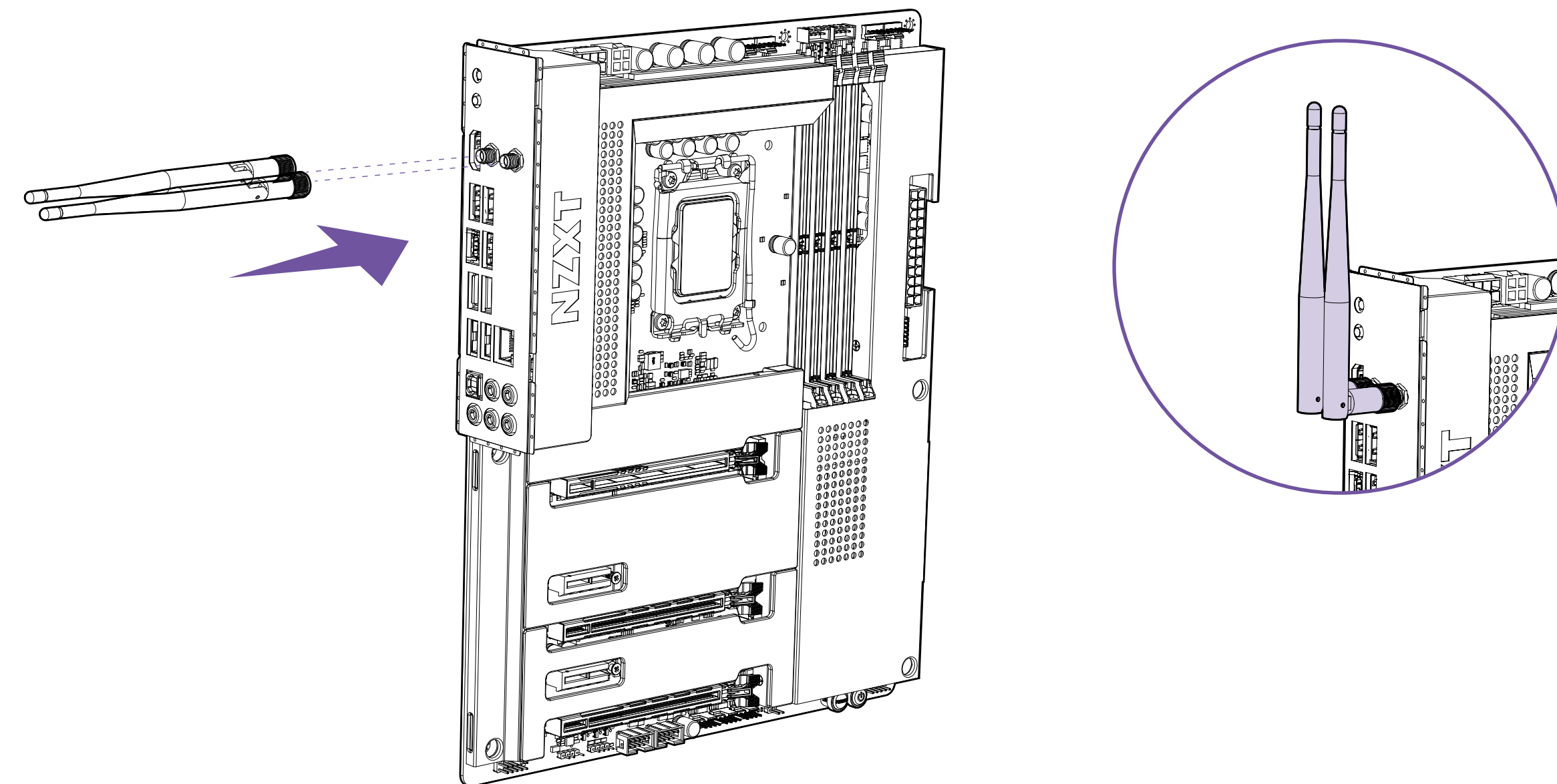

3.12 CONECTORES DE ENERGIA

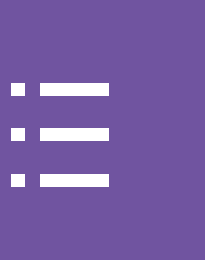

Esses conectores conectam-se a uma fonte de alimentação ATX.

OBSERVAÇÃO

- Garanta que os cabos de energia estejam bem conectados a uma fonte de alimentação ATX adequada para garantir a operação estável da placa-mãe.

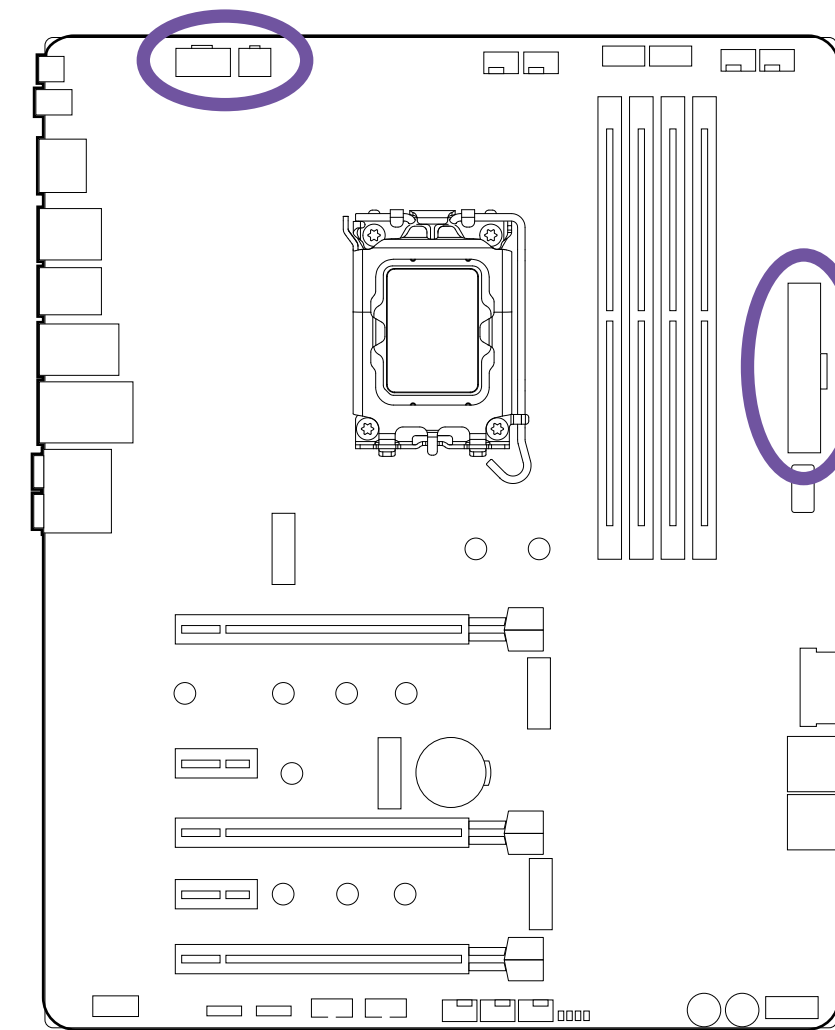

ATX_12V

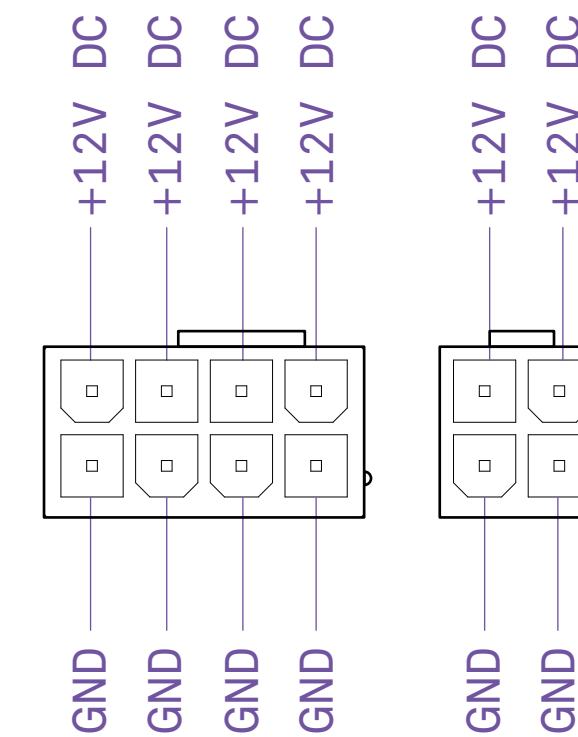

ATX_PWR

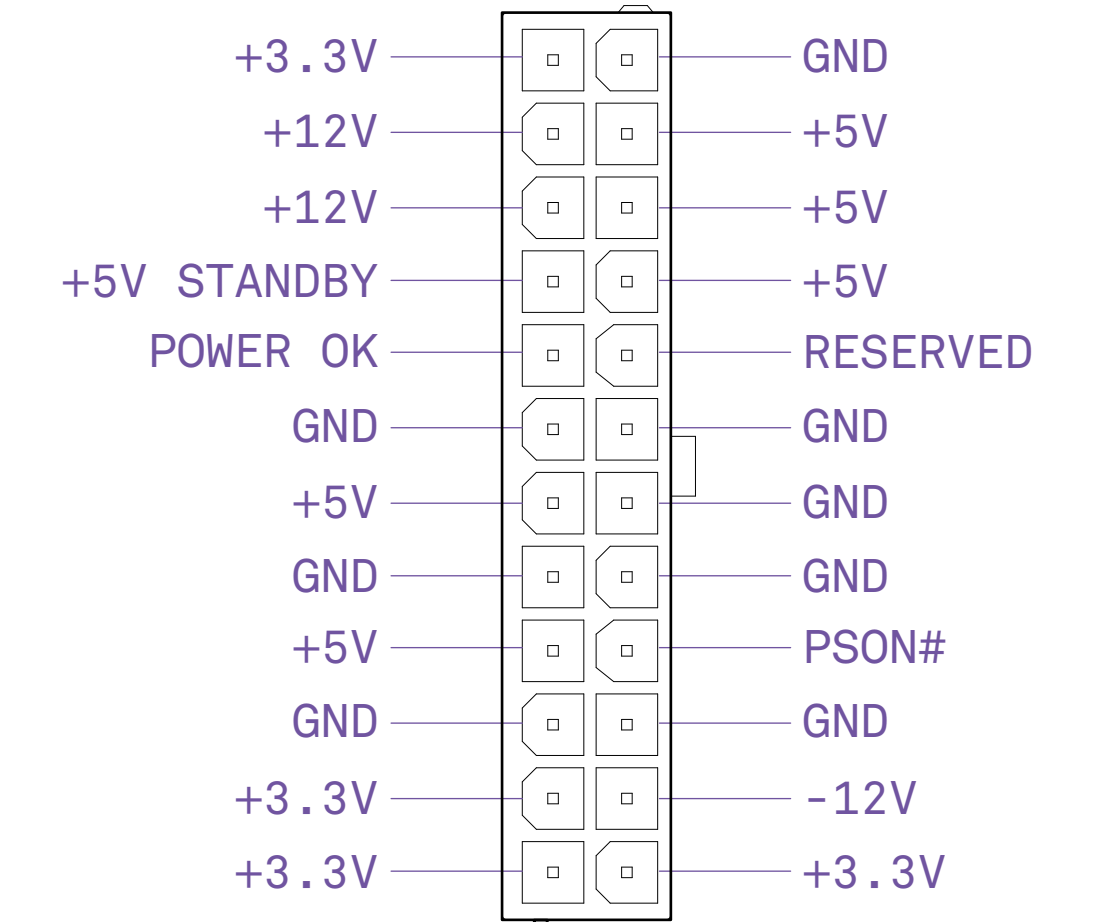

3.13 CONECTORES USB



Esses conectores permitem que você conecte as portas USB do painel frontal ou dispositivos que exigem portas USB internas.

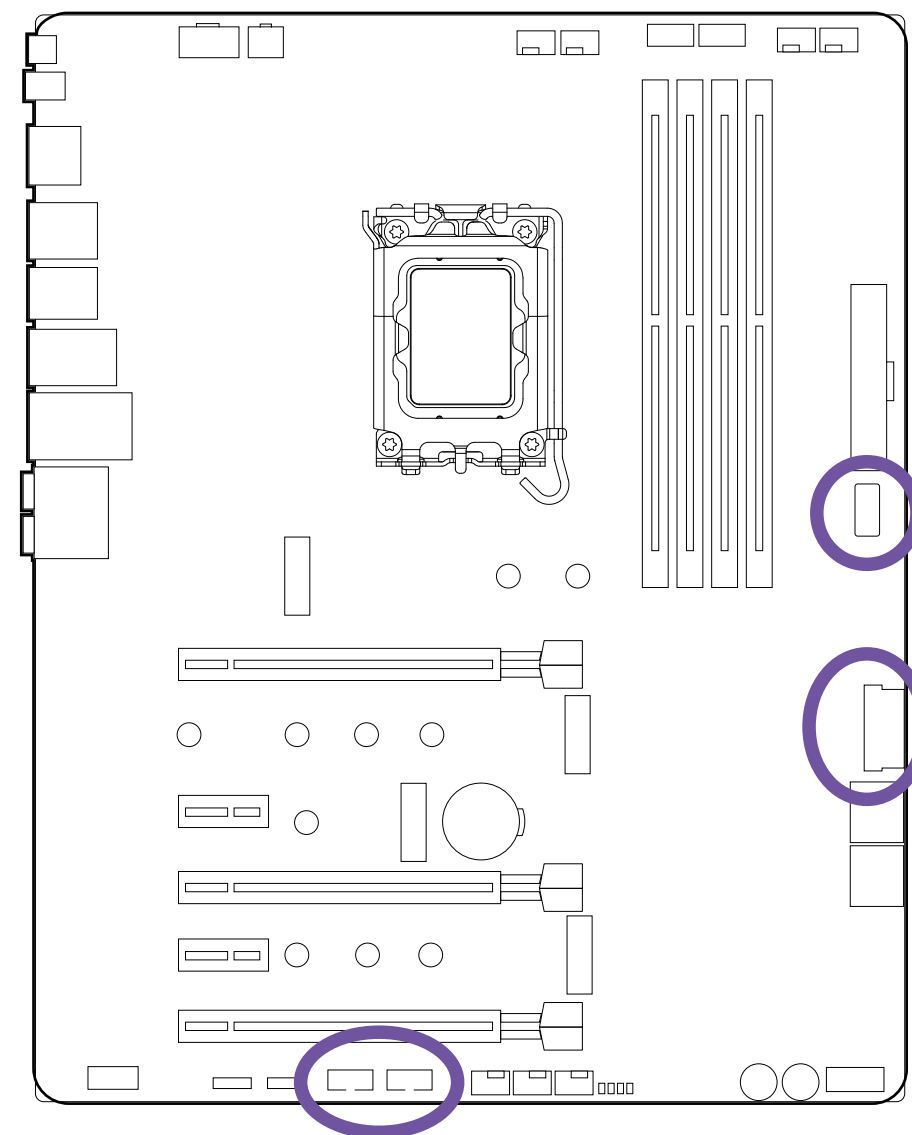

USB 2.0

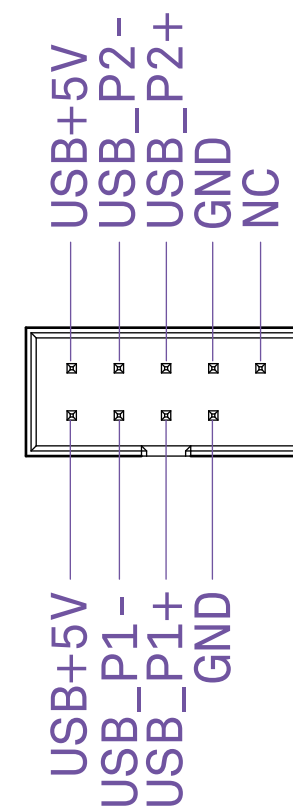

USB 3.2 Gen 1

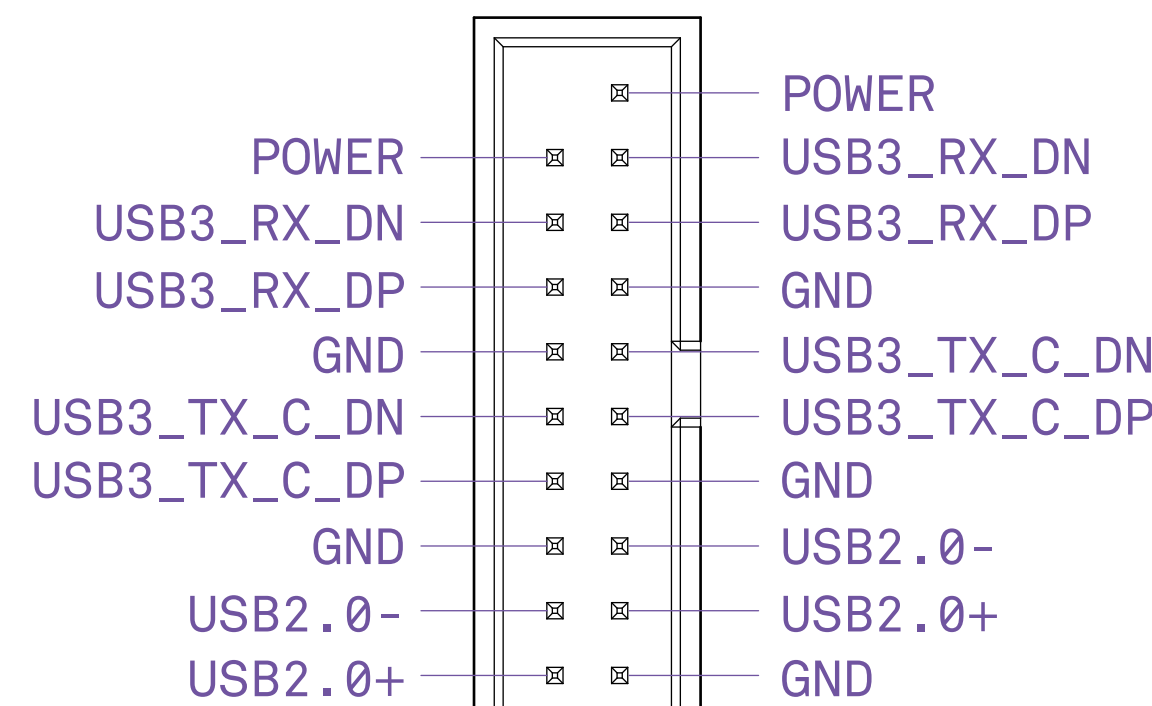

USB 3.2 Gen 2x2 Type-C

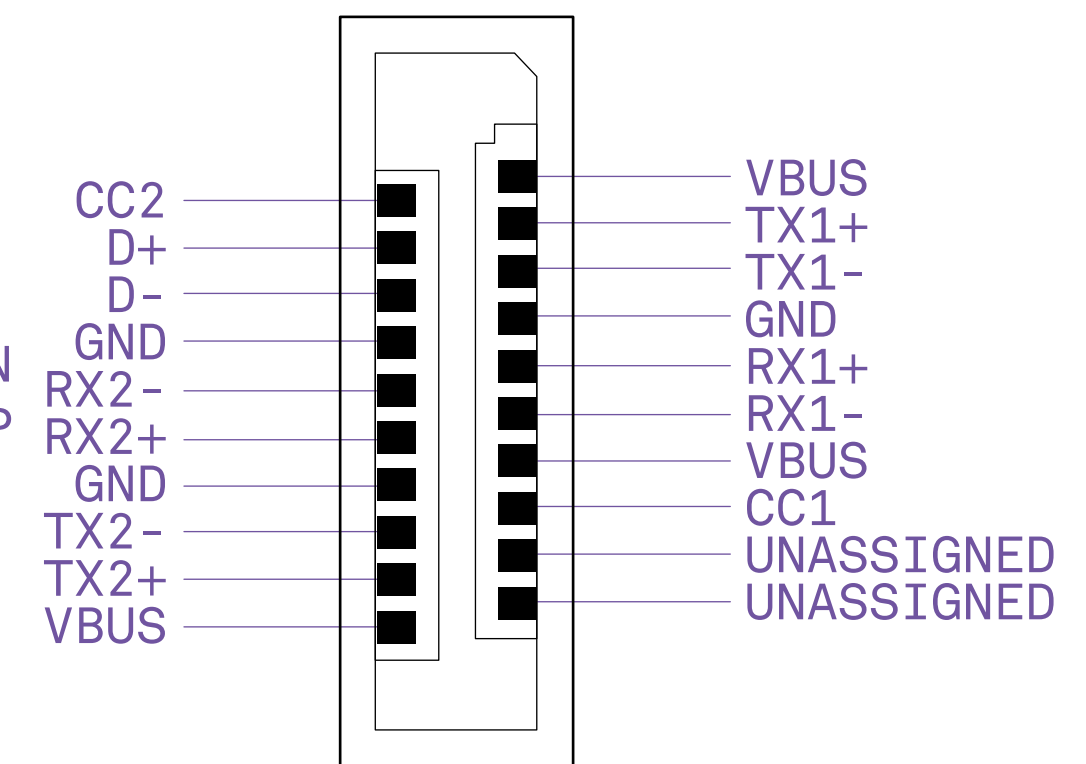

3.14 CONECTOR DE ÁUDIO DO PAINEL FRONTAL



Esse conector conecta-se ao áudio do painel frontal na caixa.

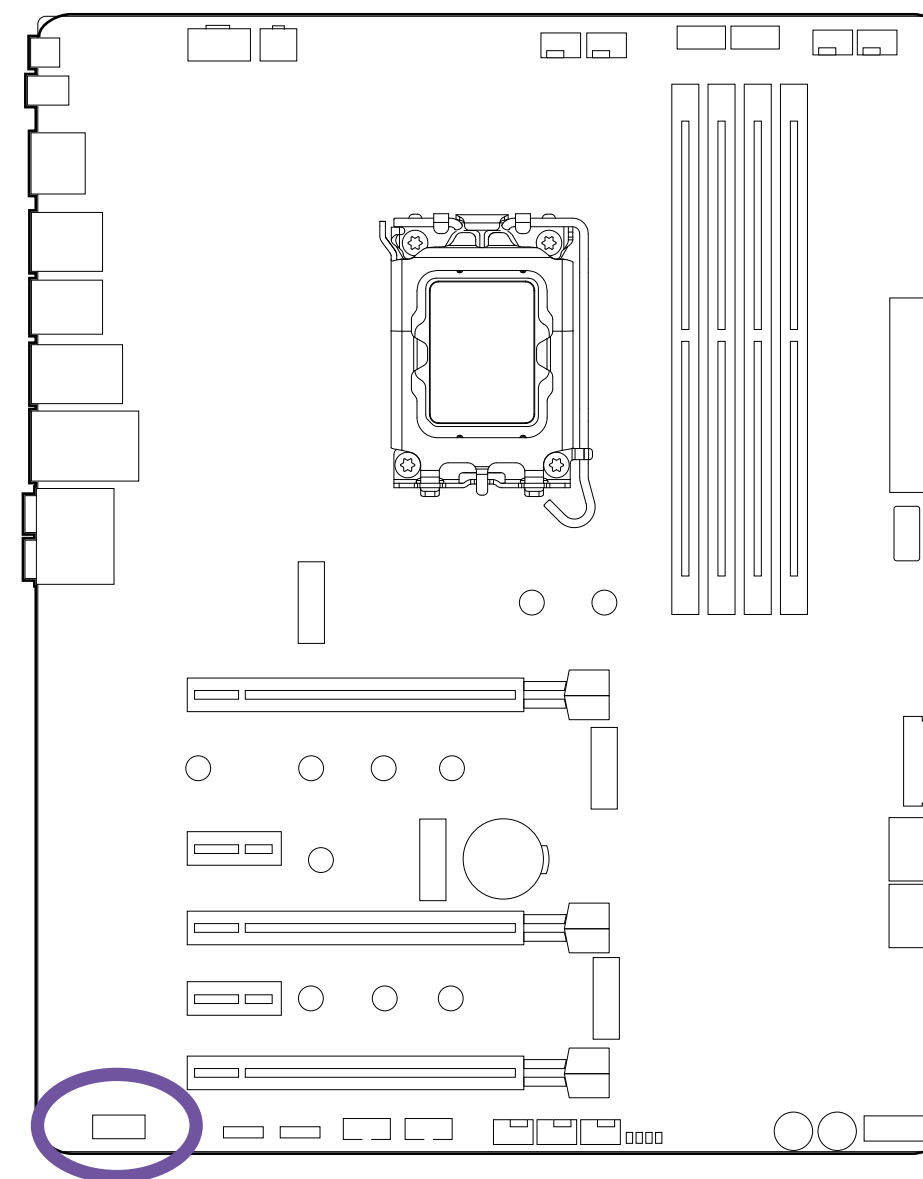

FRONT AUDIO

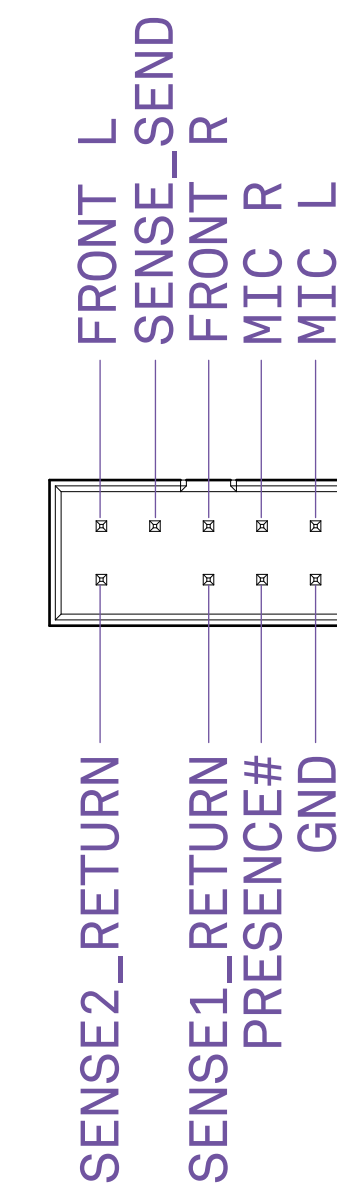

3.15 CONECTOR DO PAINEL FRONTAL



Esses conectores conectam-se aos interruptores e LEDs indicadores na caixa.

IMPORTANTE

- Verifique a polaridade dos pinos para garantir que os LEDs funcionem adequadamente.

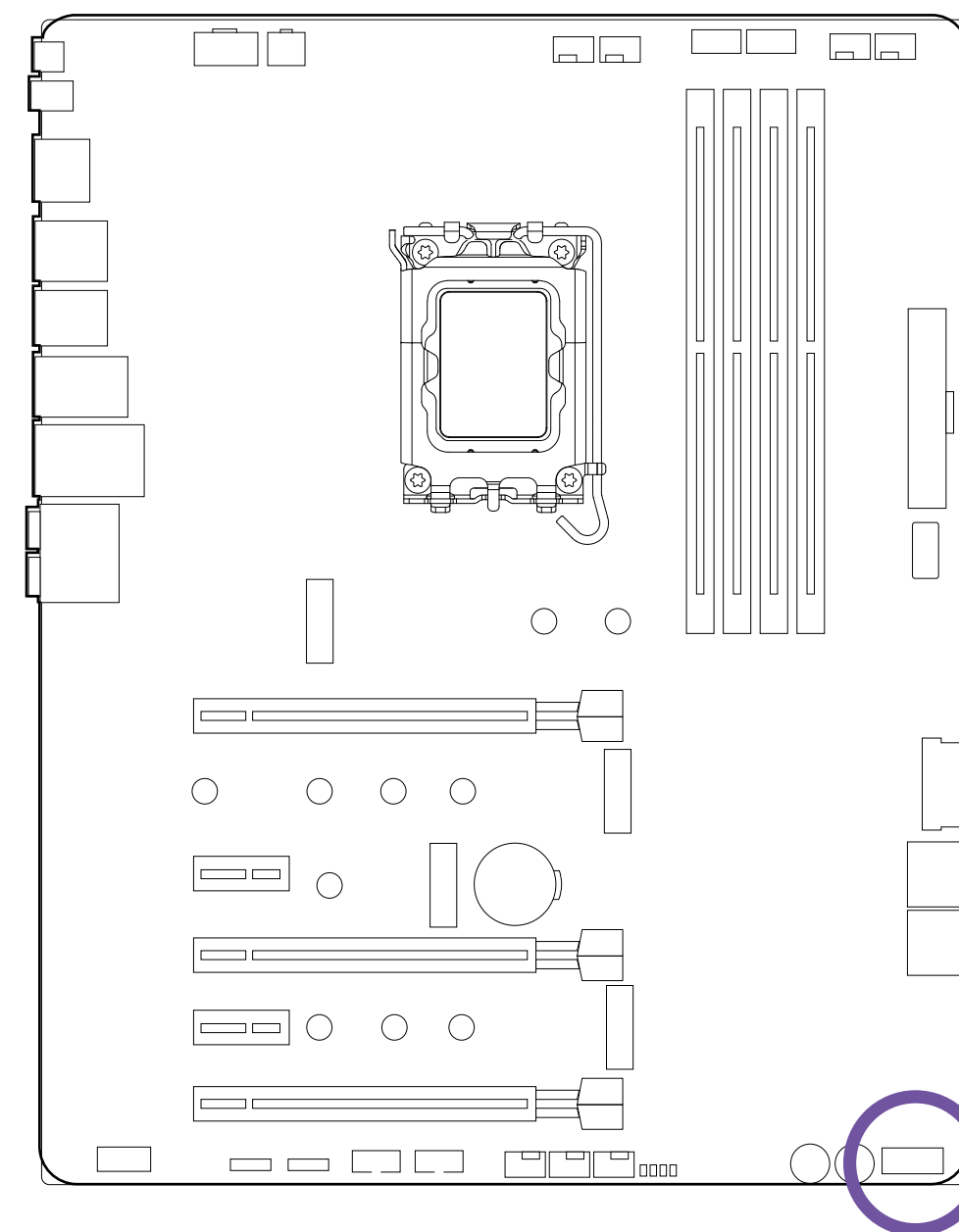

F_PANEL

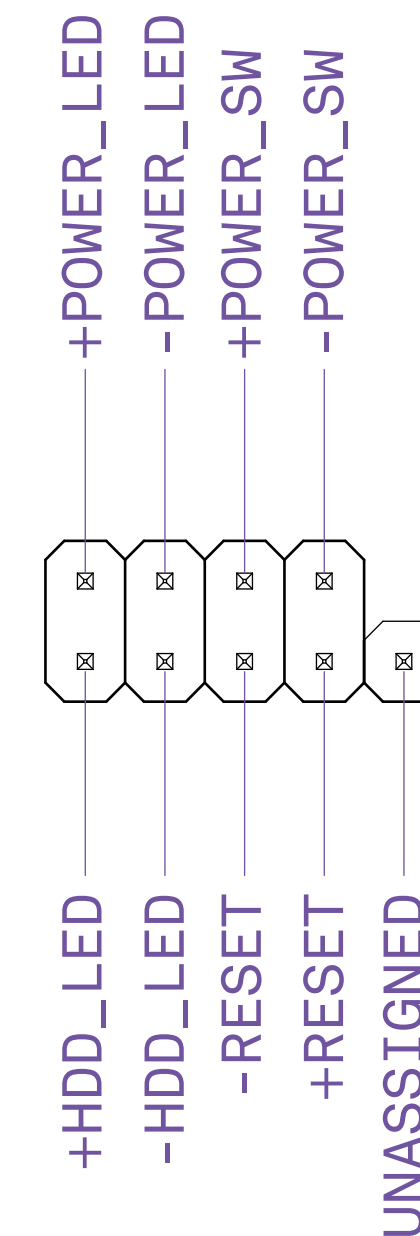

3.16 CONECTORES DO VENTILADOR



Os conectores CPU_FAN, AIO_PUMP e os quatro conectores SYS_FAN detetam automaticamente se está a ser utilizada uma ventoinha PWM (modulação por amplitude de pulso) de 4 pinos ou uma de 3 pinos e suporta até 2A (24W) de cada uma. As velocidades da ventoinha podem ser ajustadas no CAM.

OBSERVAÇÃO

- O CAM é necessário para controlar os ventiladores no Windows.

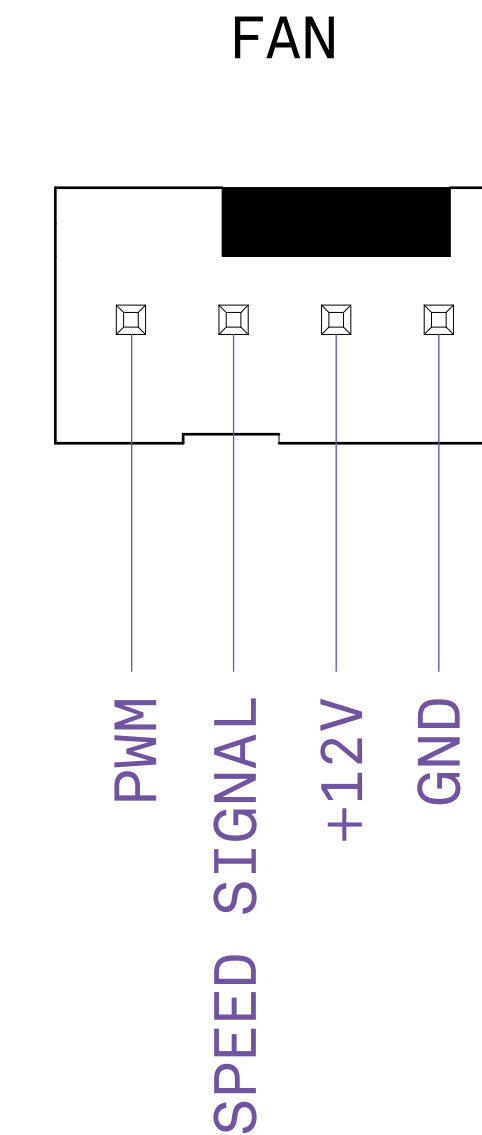
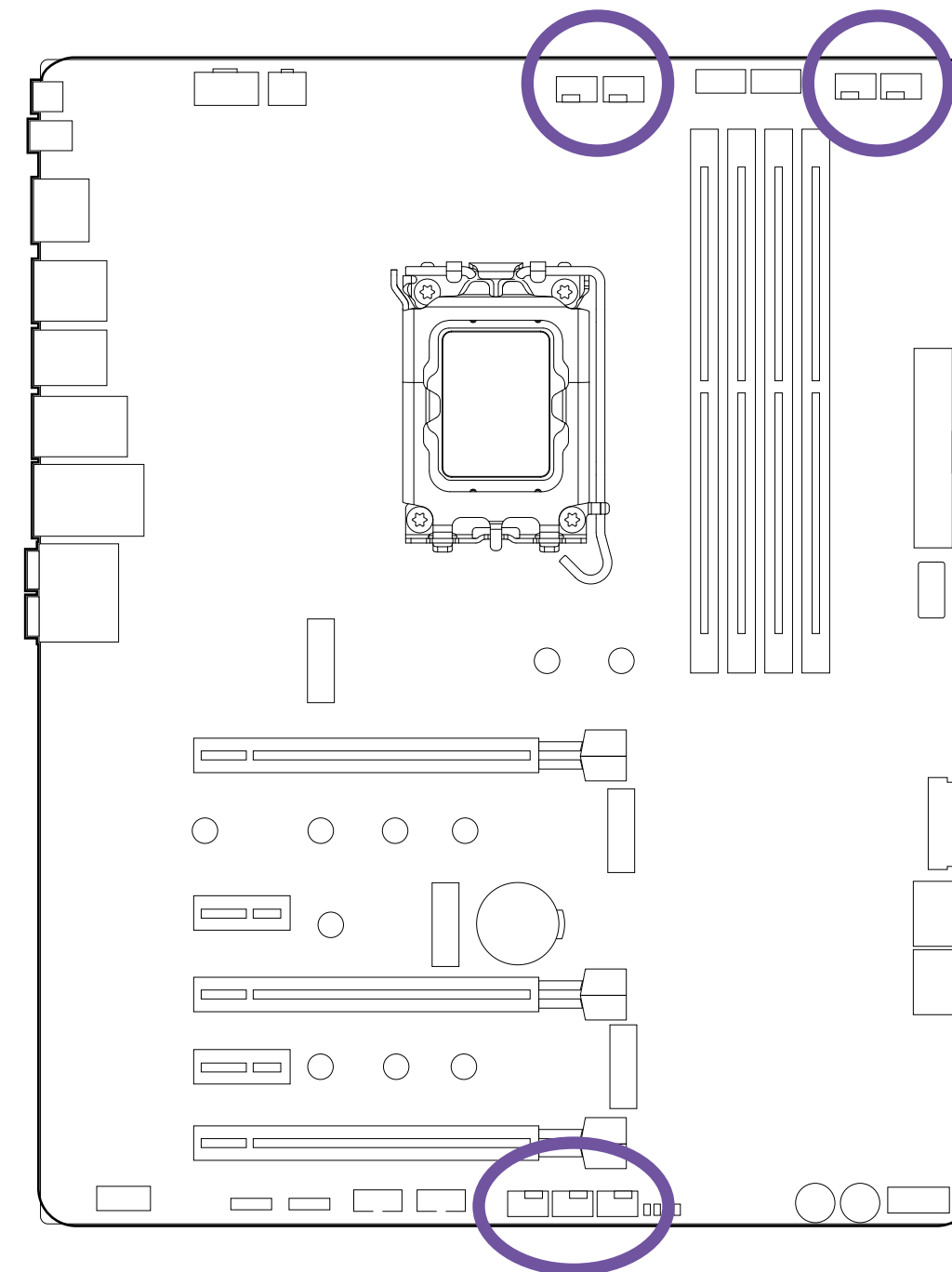

3.17 CONECTORES RGB NZXT



Há dois cabeçotes RGB NZXT na placa-mãe. As portas RGB NZXT são compatíveis com acessórios de iluminação NZXT. Cada canal tem suporte para até 40 LEDs e até seis acessórios.

OBSERVAÇÃO

- CAM é necessário para controlar a iluminação no Windows.
- Antes de instalar ou remover seus acessórios de iluminação, desligue o sistema e desconecte o cabo de energia da fonte de alimentação.

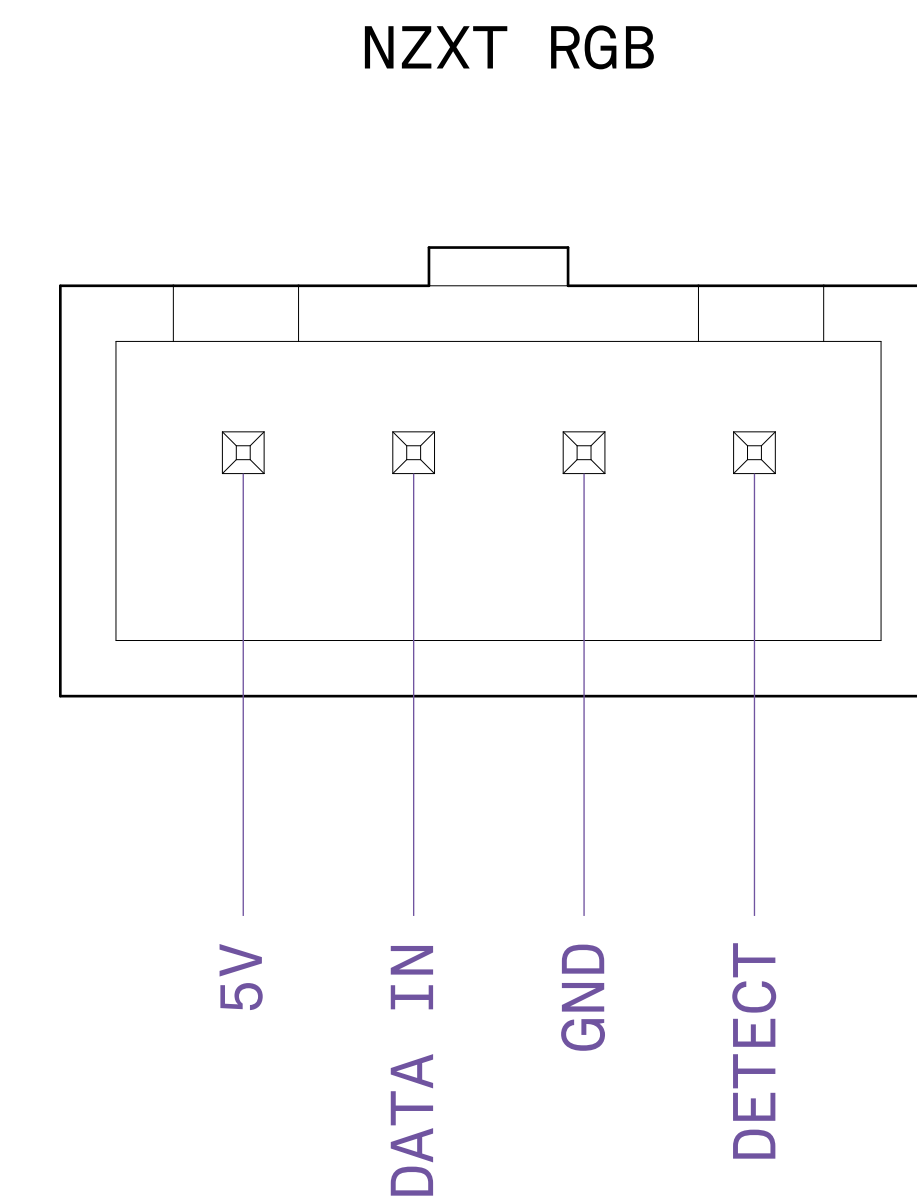
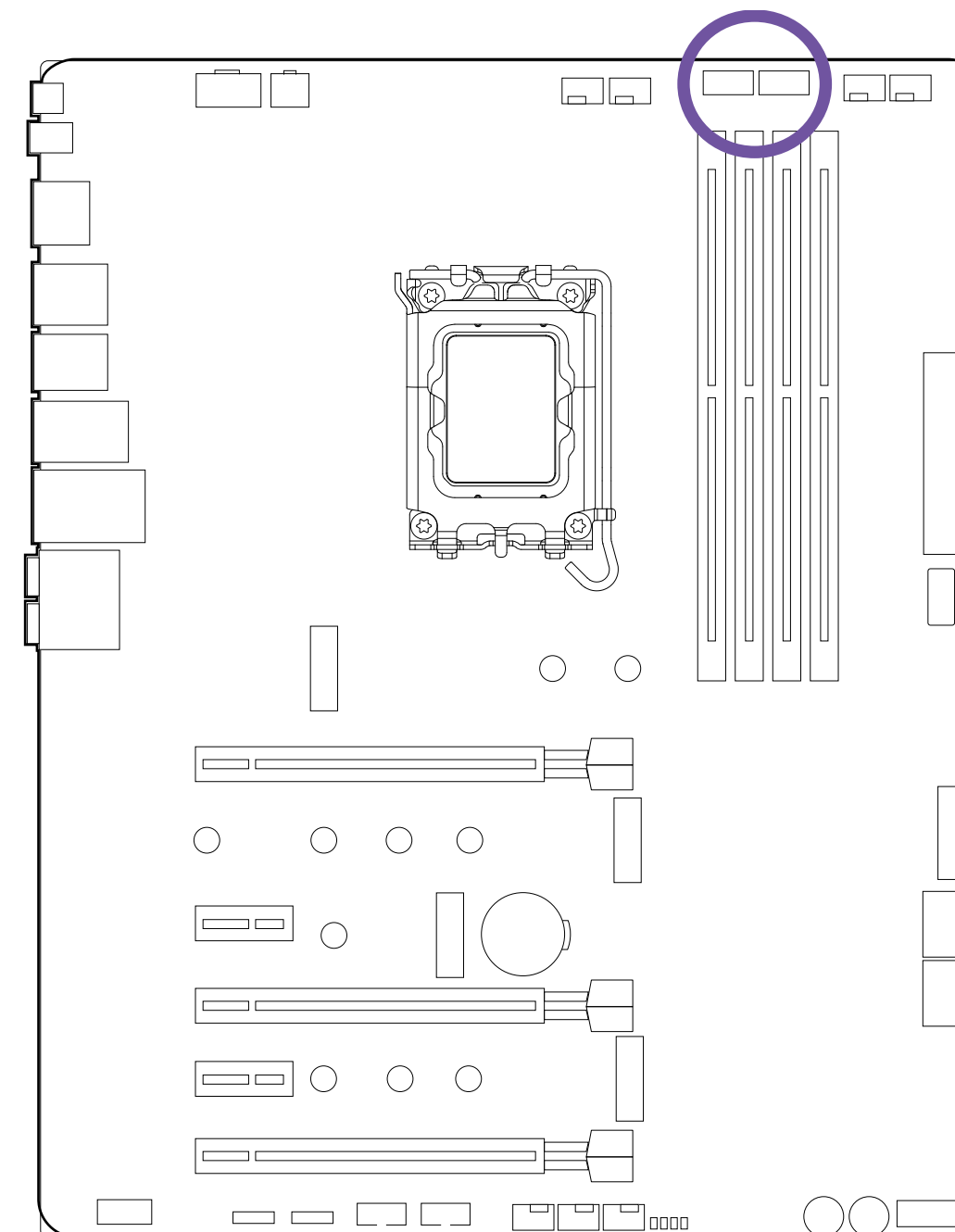

3.18 CONECTOR RGB ENDEREÇÁVEL DE 5 V



Um RGB endereçável de 5 V está localizado na placa-mãe. Essa porta é compatível com uma fita LED RGB endereçável WS2812B (5 V/dados/terra), com uma classificação de potência máxima de 3 A (5 V) e é compatível com até 40 LEDs.

OBSERVAÇÃO

- Nunca instale cabos de LED RGB na orientação incorreta para prevenir danos à placa-mãe e aos acessórios de iluminação.
- CAM é necessário para controlar a iluminação no Windows.
- Antes de instalar ou remover seus acessórios de iluminação, desligue o sistema e desconecte o cabo de energia da fonte de alimentação.

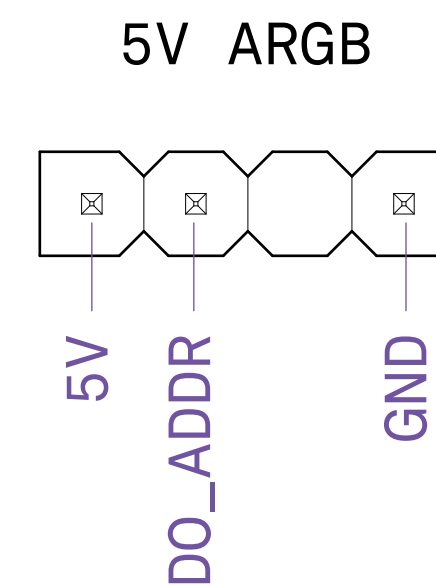
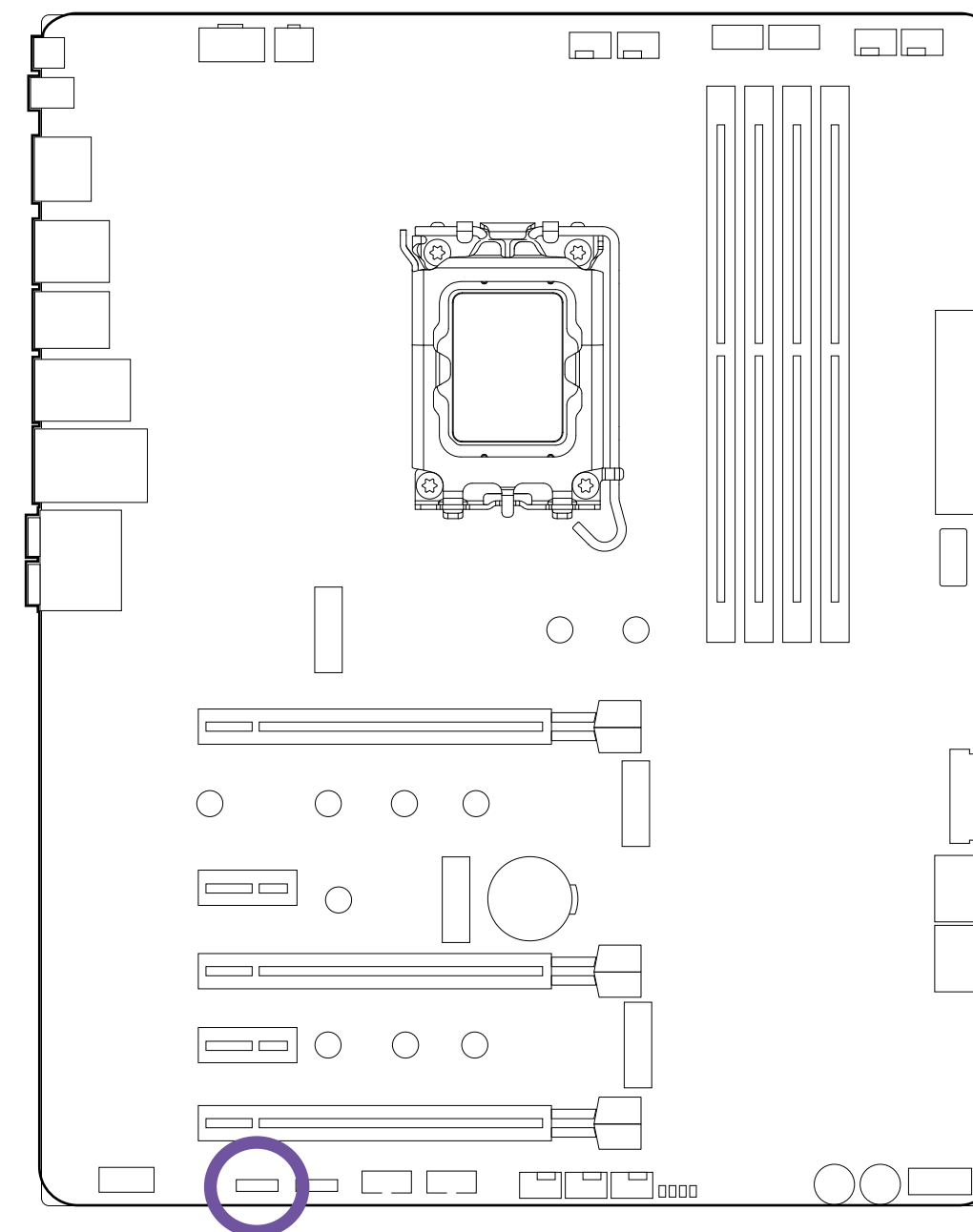

3.19 CONECTOR RGB DE 12 V



Um RGB de 12 V está localizado na placa-mãe. Essa porta oferece suporte para fita LED RGB 5050 padrão (12 V/G/R/B), com uma classificação de potência máxima de 3 A (12 V) e comprimento de até 2 metros.

OBSERVAÇÃO

- Nunca instale cabos de LED RGB na orientação incorreta para prevenir danos à placa-mãe e aos acessórios de iluminação.
- CAM é necessário para controlar a iluminação no Windows.
- Antes de instalar ou remover seus acessórios de iluminação, desligue o sistema e desconecte o cabo de energia da fonte de alimentação.

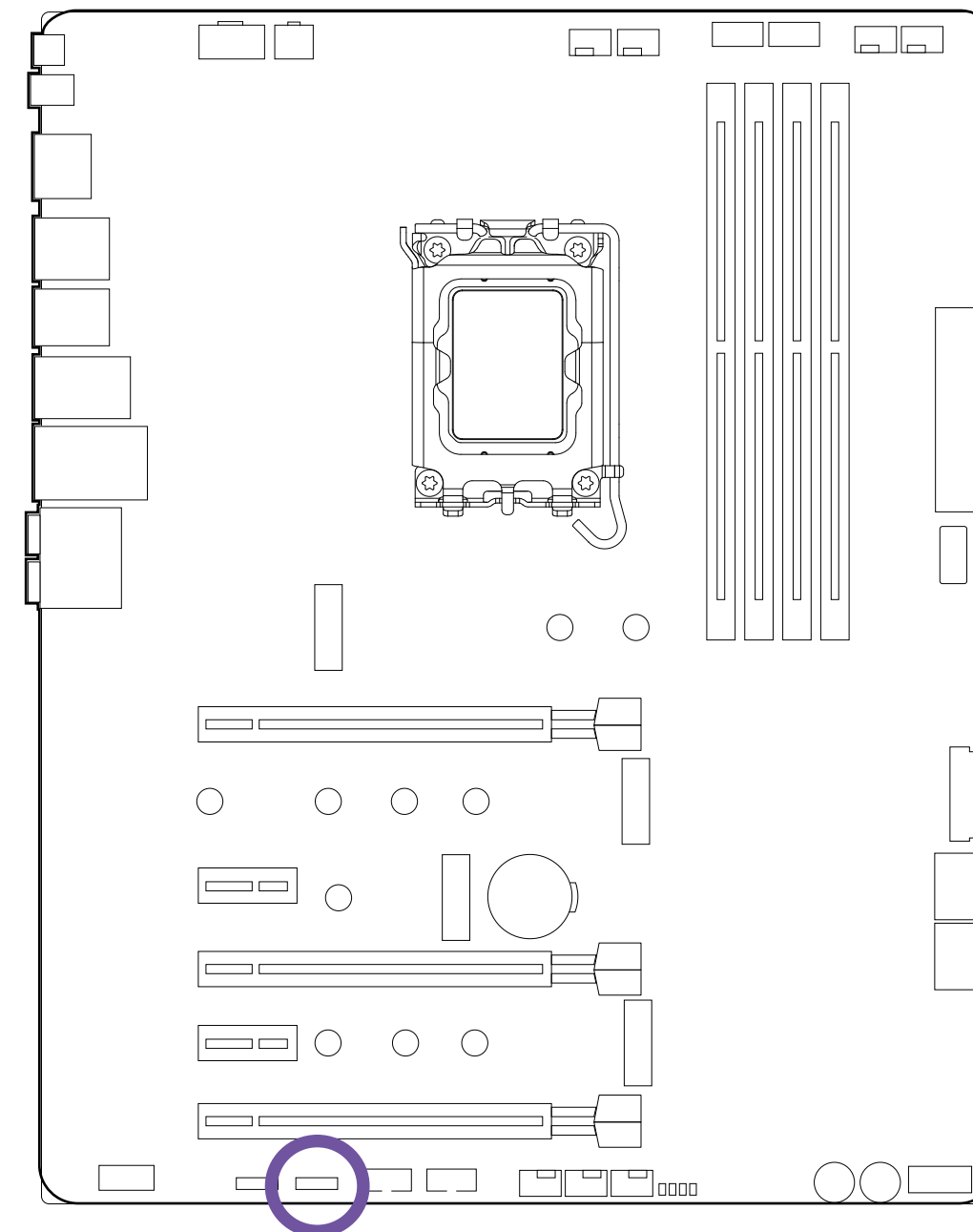

12V RGB

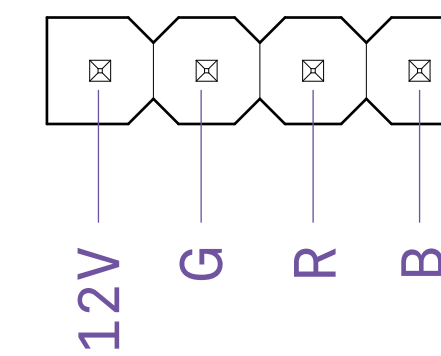



Botão Redefinir e Liga/Desliga

O botão redefinir e liga/desliga permite que você ligue e redefina a placa-mãe sem conexão a um interruptor, o que é útil para testes.

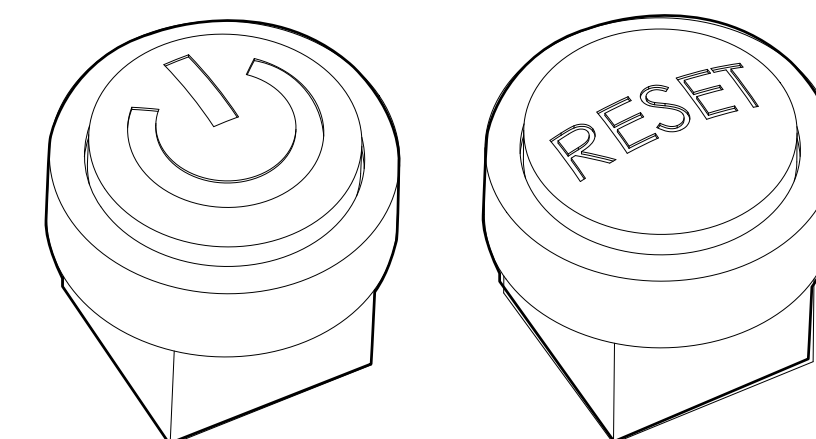
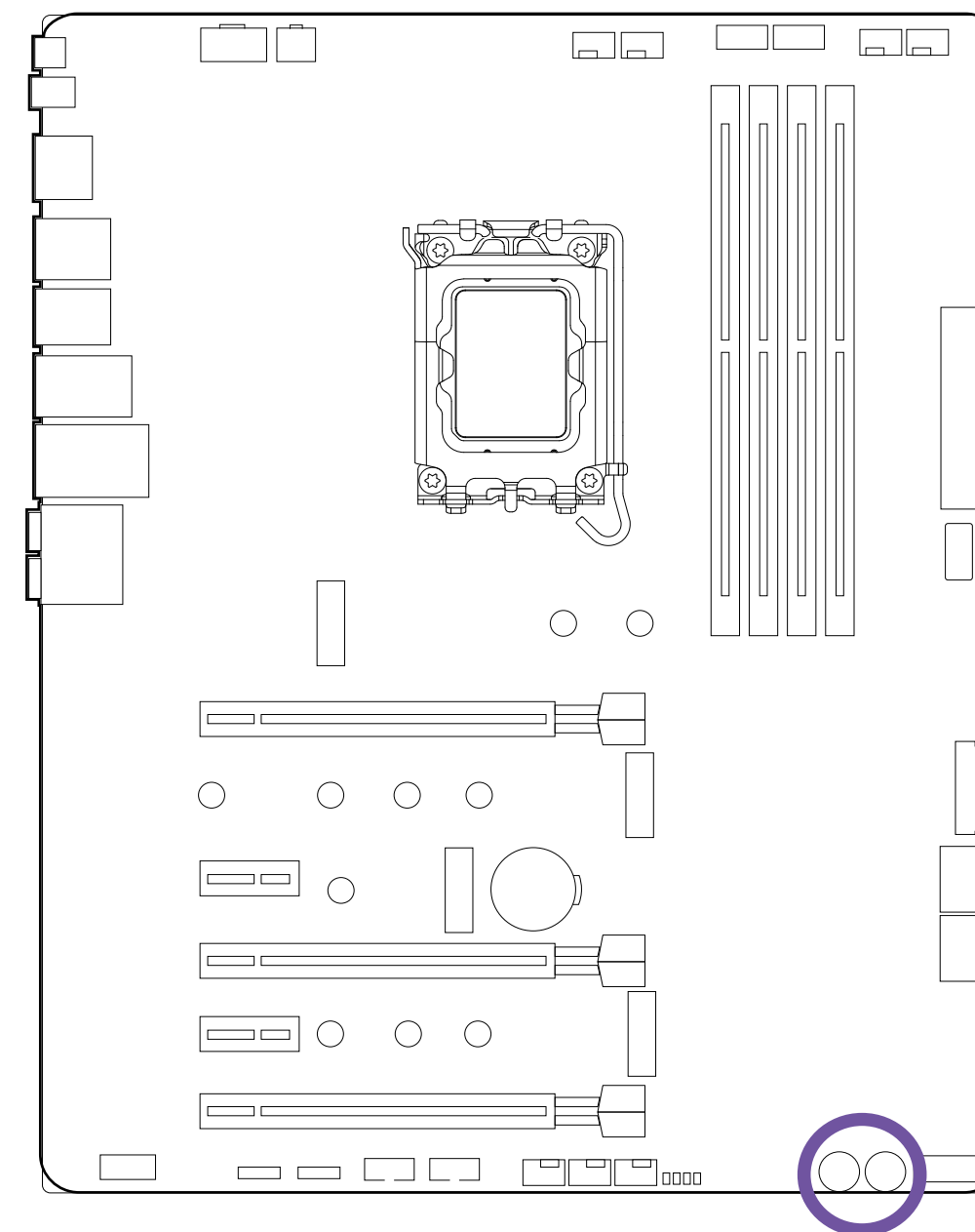



LEDs de coluna

Os LEDs de coluna fazem o diagnóstico do computador quando os usuários ligam o sistema. Eles acendem-se para indicar se há problemas de funcionamento na CPU, na memória, no VGA ou no armazenamento. As luzes apagam-se quando os quatro itens indicados acima estão funcionando adequadamente.

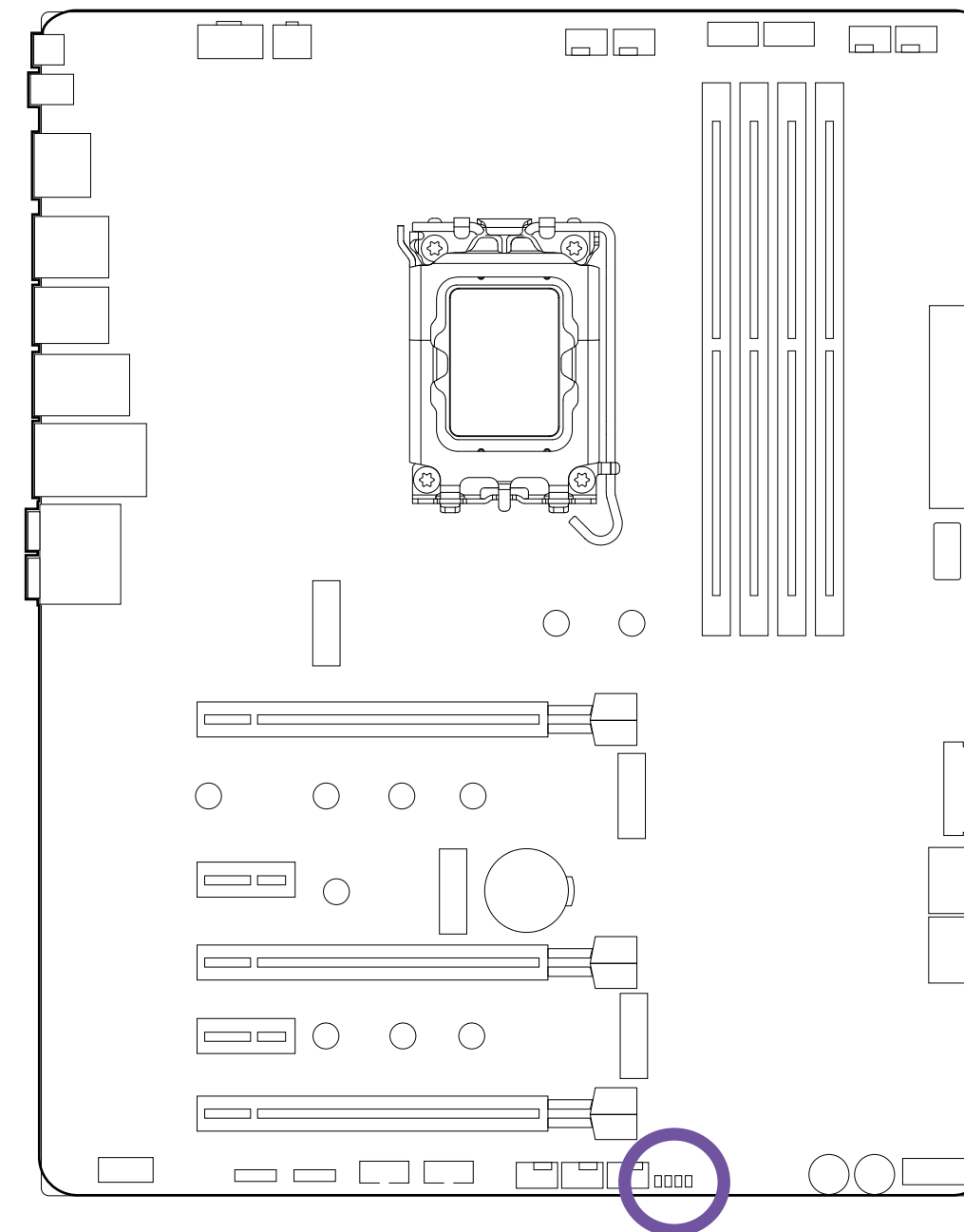



Botão Limpar CMOS

O botão Limpar CMOS na E/S traseira pode ser usado para reverter as configurações do BIOS para o padrão. Para limpar o CMOS, desligue a energia e remova a energia CA para a fonte de alimentação. Aguarde 30 segundos para garantir que não haja energia em espera. Pressione e segure o botão Limpar CMOS por 3 segundos.

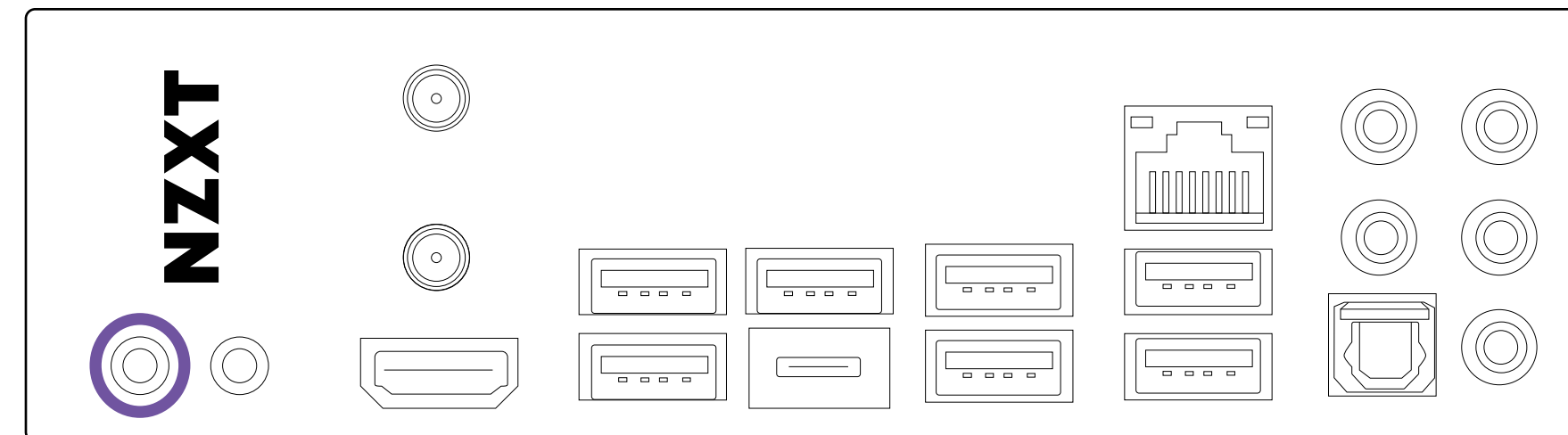

3.21 BATERIA CMOS



Caso as suas configurações de BIOS não possam mais ser salvas, é provável que a bateria do CMOS da placa-mãe (CR2032) não segure mais a carga. Pode aceder à bateria e trocá-la removendo a tampa metálica.

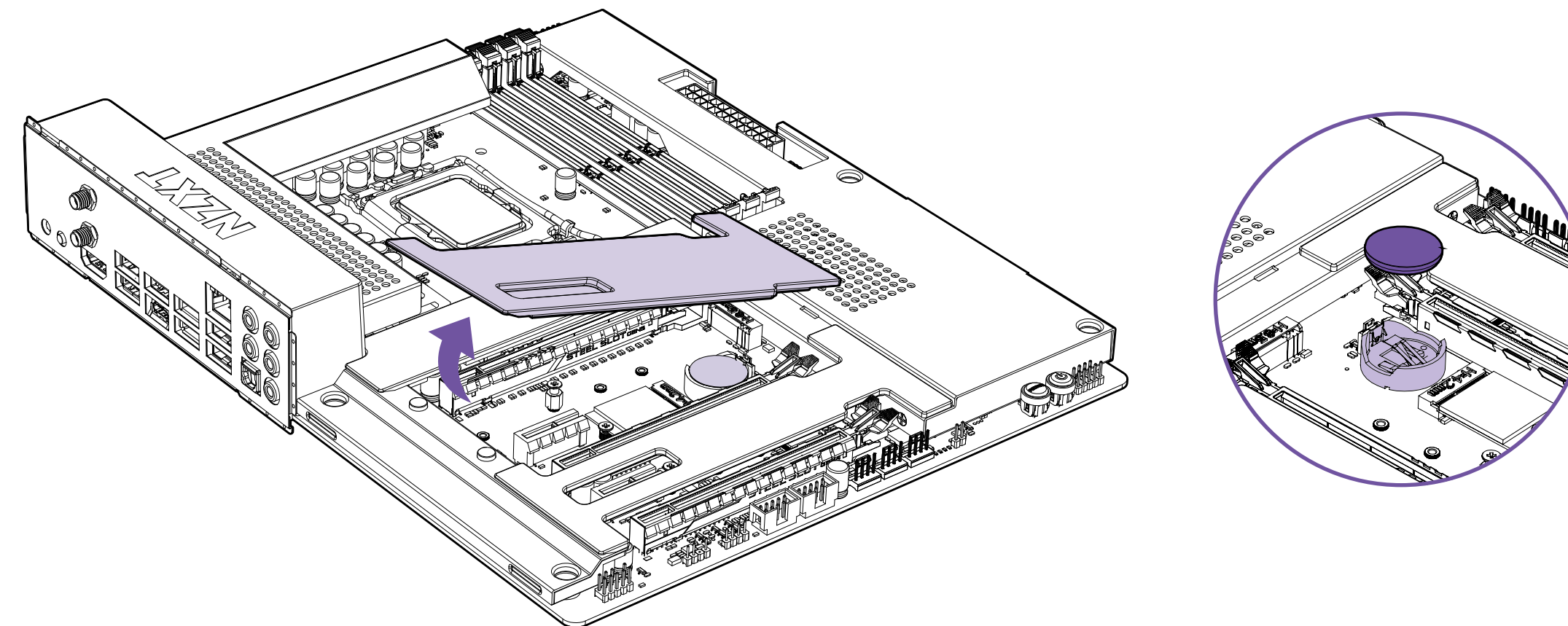

3.22 BIOS FLASHBACK

Com uma unidade flash USB e o BIOS mais recente, você pode atualizar o BIOS sem uma CPU e não é necessário ligar o sistema. Para usar o recurso BIOS Flashback, execute as etapas abaixo.

⚠ OBSERVAÇÃO

- Um sistema de PC separado é necessário para preparar a unidade flash USB.
- Se o LED ficar estático em verde, isso significa que o BIOS Flashback não está funcionando corretamente. Conecte a unidade USB na porta USB do BIOS Flashback.

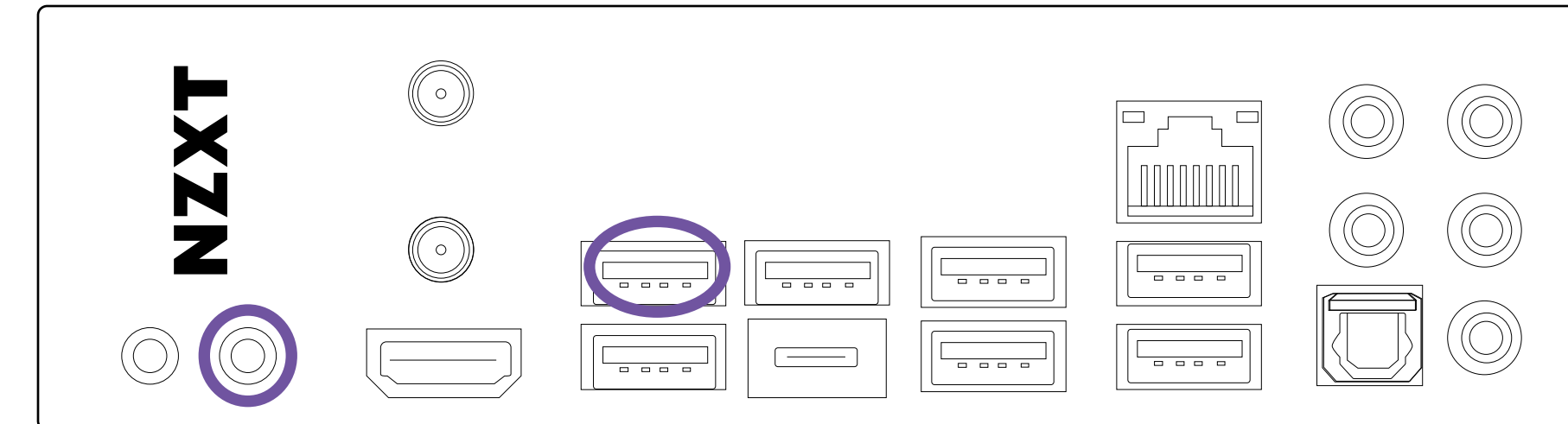

- Baixe o arquivo BIOS mais recente do site da NZXT: <http://www.nzxt.com>.
- Extraia o arquivo do BIOS do arquivo zip para um local seguro e altere o nome dele para arquivo BIOS "creative.rom".
- Prepare uma unidade flash USB, formate-a em FAT32 e copie "creative.rom" para o diretório raiz na unidade flash.
- Insira o conector de alimentação de 24 pinos na placa-mãe e ative o interruptor de CA da fonte de alimentação. Não ligue o sistema.
- Insira a unidade flash USB no conector USB rotulado com "BIOS" no painel de entrada/saída traseiro.
- Pressione o botão BIOS Flashback por aproximadamente três segundos para iniciar o processo. O botão piscará para indicar que o processo começou.
- Aguarde até o LED parar de pisar e desligar, indicando que o processo de atualização do BIOS foi concluído.



NZXT CAM

Download and install NZXT CAM from nzxt.com/camapp.

Descargue e instale NZXT CAM en nzxt.com/camapp.

Téléchargez et installez NZXT CAM depuis nzxt.com/camapp.

laden Sie NZXT CAM von nzxt.com/camapp herunter und installieren Sie die Software.

Scaricare e installare NZXT CAM da nzxt.com/camapp.

Baixe e instale o NZXT CAM de nzxt.com/camapp.

загрузите и установите приложение NZXT CAM со страницы nzxt.com/camapp.

nzxt.com/camapp 에서 NZXT CAM을 다운로드하여 설치하십시오.

NZXT CAMは nzxt.com/camapp からダウンロード・インストール可能です。

請從：nzxt.com/camapp 下載並安裝 NZXT CAM 軟件。

請從 nzxt.com/camapp 下載並安裝 NZXT CAM。

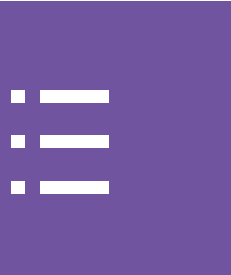

5.1 NZXT Global Warranty Policy..... A-2

5.4 Battery Information A-13

5.2 Support and Service..... A-8

5.5 WEEE Statement A-14

5.3 Regulatory Notices..... A-11

5.6 Revision History..... A-18

5.1 NZXT GLOBAL WARRANTY POLICY

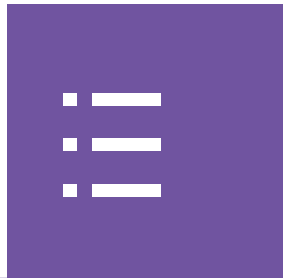

This NZXT Global Warranty Policy governs the sale of products by NZXT to you.

I. WARRANTY LENGTH

Any replacement product will be covered under warranty for the remainder of the warranty period or thirty days, whichever is longer. Proof of purchase is required for warranty service.

II. WHO IS PROTECTED

The Warranty covers only NZXT products purchased by the original consumer.

NEW NZXT PRODUCT	WARRANTY LENGTH FOR PARTS
Computer Cases	2 Years
Temperature Meters	2 Years
Fans	2 Years
Lighting	2 Years
Accessories	2 Years
Kraken M Coolers	3 Years
Headset/Headphone	2 Years
Headset/Headphone Storage	2 Years
Mixer	2 Years
Motherboards	3 Years
Gold Power Supply	10 Years
Kraken X/Z Coolers	6 Years
Mini ITX Case with PSU, AIO, and Riser Card	3-year warranty on case, riser card, and AIO. 10-year warranty on PSU.
REFURBISHED NZXT PRODUCT	WARRANTY LENGTH FOR PARTS
All NZXT Certified Refurbished Products	1 Years



III. WHAT IS AND IS NOT COVERED

Please note that our warranty is not an unconditional guarantee. If the product, in NZXT's reasonable opinion, malfunctions within the warranty period, NZXT will provide you at its sole discretion with a repaired or replacement product, either new or refurbished, with a similar function that is equal or greater in value depending on supply.

Our warranty does not cover the following:

- any product or serial number/warranty sticker modification applied without permission from NZXT;
- any damage that is not a manufacturing defect;
- damage, deterioration or malfunction resulting from: accident, abuse, misuse, neglect, fire, water, lightning, or other acts of nature, unauthorized product modification or failure to follow instructions included with the product;
- improper installation, unauthorized alterations or modifications, or repair or attempted repair by anyone not authorized by NZXT;
- shipping or transport damage (claims must be made with the carrier);
- normal wear and tear.

NZXT does not warrant that this product will meet your requirements. It is your responsibility to determine the suitability of this product for your purpose. For NZXT Store orders, we cover two way return shipping for all exchanges and returns. For all other authorized dealers, NZXT Support does not cover return shipping and only covers one way shipping from NZXT back to the end user for exchanges. Two way expedited shipping is provided for all PSUs covered under the Less Than Three program, indiscriminate of purchase location, provided the location is an approved NZXT reseller.

IV. EXCLUSION OF DAMAGES (DISCLAIMER)

NZXT's sole obligation and liability under this warranty is limited to the repair or replacement of a defective product with either a new or refurbished product with a similar function that is equal or greater in value at our option. NZXT shall not, in any event, be liable for any incidental or consequential damage, including but not limited to damages resulting from interruption of service and loss of data, business, or for liability in tort relating to this product or resulting from its use or possession.



V. LIMITATIONS OF IMPLIED WARRANTIES

Here are no other warranties, expressed or implied, including but not limited to those of merchantability or fitness for a particular purpose. The duration of implied warranties is limited to the warranty length specified in Paragraph I.

VI. TO OBTAIN TECHNICAL SUPPORT

If you have already referenced your product owner's manual and still need help, you may contact us by phone at +1 (800) 228-9395, by email at service@nzxt.com, or visit the NZXT Support site at nzxt.com/customer-support.

VII. HOW TO OBTAIN A WARRANTY SERVICE FROM NZXT

To receive a warranty service for your product when purchased directly from NZXT, you must submit a request via the NZXT Support site outlining the problem. If a technician deems the product defective or requiring testing, you will be required to provide a copy of your proof of purchase, which will enable you to submit a Return Merchandise Authorization "RMA" request.

Once approved, you`ll receive an RMA number, upon which you will be asked to ship the defective item back to NZXT with the RMA number clearly marked or labelled on the package. NZXT recommends that appropriate measures are taken to safeguard the product from damage during shipping.



VIII. APPLICABLE LAW AND ADDITIONAL LEGAL RIGHTS FOR CONSUMERS

This warranty gives you specific legal rights. These conditions are governed and construed in accordance with the laws of California (with exception of its conflict of law provisions), and the application of the United Nations Convention of Contracts for the International Sale of Goods is expressly excluded. The non-exclusive jurisdiction of the courts of California is agreed, which means that you may bring a claim to enforce your consumer protection rights in connection with this Global Warranty in the country which you have your habitual residence where you may have additional rights. These rights may vary.

For original consumers who are covered by consumer protection laws or regulations in their country, state, or province of purchase or, if different, their country, state, or province of residence, the benefits conferred by this warranty are in addition to all rights and remedies conveyed by such consumer protection laws and regulations. To the extent that liability under such consumer laws can be limited, NZXT's liability is limited, and its sole option, to repair or replacement, either new or refurbished, with a similar function that is equal or greater in value depending on supply.

In the United Kingdom:

- For NZXT products sold to customers in the UK, during the expected lifespan of your product your legal rights entitle you to the following:
 - > Up to 30 days: if your goods are faulty, then you can get an immediate refund.
 - > Up to six months: if your goods can't be repaired or replaced, then you're entitled to a full refund, in most cases.
 - > Up to six years: if your goods do not last a reasonable length of time you may be entitled to some money back.
- If the person seeking to rely on the guarantee is not the original consumer, the NZXT Warranty will cover the product in relation to that person provided that they are able to provide proof of the transfer of the benefit of the guarantee from the original consumer.
- The implied warranties under the Consumer Rights Act 2015 says that your goods must be as described, fit for all purposes for which such goods are usually supplied, and of satisfactory quality.

In the EU:

- If you are a consumer and have your habitual residence in the EU, you additionally enjoy the protection afforded to you by provisions that cannot be derogated from by agreement by virtue of the law where you have your habitual residence.



IX. WARRANTY SERVICE FROM RESELLERS

In the event that a warranty service is sought, you must provide proof of purchase (store receipt or invoice) in order to receive the service and if deemed necessary, repair or replacement product.

In North America:

Within the first 60 days after purchase, please return your product (or for power supplies installed within our enclosures, just the failed power supply) to your dealer or reseller for a replacement. If the product is still within warranty and you can no longer return it to your dealer, please contact NZXT Customer Support (see above) for assistance and instructions. NZXT will not accept returns without prior approval and an RMA number.

In Europe:

Within the first year after purchase, please return your product (or for power supplies installed within our enclosures, just the failed power supply) to your dealer or reseller for a replacement. If the product is still within warranty and you can no longer return it to your dealer, please contact NZXT Customer Support (see above) for assistance and instructions. NZXT will not accept returns without prior approval.

In Australasia:

Within the first two years after purchase, please return your product (or for power supplies installed within our enclosures, just the failed power supply) to your dealer or reseller for a replacement. If the product is still within warranty and you can no longer return it to your dealer, please contact NZXT Customer Support (see above) for assistance and instructions. NZXT will not accept returns without prior approval.

The cost of shipping will be borne at the first instance by you; however, if the purchased item is defective, NZXT will reimburse reasonable postage or transportation of costs.

Outside North America, Europe, and Australasia:

If your product needs to be returned within the warranty period, please contact the retailer or distributor from whom you purchased the product.



X. NZXT.COM STORE RETURNS/EXCHANGE POLICY

Eligible products under this NZXT Warranty qualify for a full refund or exchange only with an authorized RMA number and if the item is returned to the NZXT.com store inventory within 30 days of purchase. Returns are not allowed beyond 30 days of the purchase date. The NZXT.com Store reserves the right to deny any return or exchange. Refunds will be credited to the original method of payment. To initiate a return, simply submit a request via NZXT support site.

- > Visit nzxt.com/warranty and support.nzxt.com for information on warranty coverage and service.
- > Visite el sitio Web nzxt.com/warranty y support.nzxt.com para obtener información sobre la cobertura y el servicio de la garantía.
- > Visitez nzxt.com/warranty et support.nzxt.com pour les informations de la couverture de la garantie et du service.
- > Informationen zu Geltungsbereich und Service der Garantie finden Sie unter support.nzxt.com und nzxt.com/warranty.
- > Visitare il sito nzxt.com/warranty e support.nzxt.com per informazioni sulla copertura e sul servizio della garanzia.
- > Visite nzxt.com/warranty e support.nzxt.com para obter informações sobre a cobertura da garantia e assistência.
- > Подробную информацию об условиях гарантийного обслуживания см. на веб-сайте nzxt.com/warranty и support.nzxt.com.
- > 제품 보증 범위와 서비스 정보를 확인하시려면 nzxt.com/warranty 또는 support.nzxt.com 을 방문해 주시기 바랍니다.
- > 保証範囲およびサービスに関する情報については、support.nzxt.com と nzxt.com/warranty にアクセスしてください。
- > 请造访 nzxt.com/warranty 和 support.nzxt.com 了解保修范围和服务的信息。
- > 請訪問 nzxt.com/warranty 和 support.nzxt.com 了解產品保固範圍和更多服務訊息。

NZXT, Inc./ 15736 E Valley Blvd, City of Industry, CA 91744, USA
NZXT Europe GmbH/ Industriering Ost 66 | 47906 Kempen | Germany
+1 (800) 228-9395 / service@nzxt.com / [NZXT.com](https://nzxt.com)



SUPPORT AND SERVICE

If you have any questions or problems with the NZXT product you purchased, please don't hesitate to contact us using our support system. support.nzxt.com

Please include a detailed explanation of your problem and your proof of purchase. For comments and suggestions, you can e-mail our design team, designer@nzxt.com. Lastly we would like to thank you for your support by purchasing this product.

For more information about NZXT, please visit us online. NZXT Website: [NZXT.com](https://nzxt.com)

SOPORTE Y SERVICIO

Si tiene preguntas o problemas con el producto NZXT que usted compró, no dude en ponerse en contacto con service@nzxt.com y suministrar una explicación detallada de su problema así como su prueba de compra. Puede hacer consultas sobre piezas de repuesto en support.nzxt.com. Para comentarios y sugerencias, escriba un mensaje de correo electrónico a nuestro equipo de diseño: designer@nzxt.com. Gracias por comprar un producto NZXT. Para más información acerca de NZXT, visítenos en línea. Página web de NZXT: [NZXT.com](https://nzxt.com)

SUPPORT ET SERVICE

Si vous avez des questions ou des problèmes avec le produit NZXT que vous avez acheté, n'hésitez pas à contacter service@nzxt.com avec une description détaillée de votre problème et votre preuve d'achat. Vous pouvez aussi commander des pièces de remplacement auprès support.nzxt.com. Pour les commentaires et les suggestions, envoyez un email à notre équipe de design, designer@nzxt.com. Merci d'avoir acheté ce produit de NZXT. Pour plus d'informations sur NZXT, visitez notre site Web. Site Web de NZXT : [NZXT.com](https://nzxt.com)

KUNDENDIENST UND SERVICE

Falls Fragen oder Probleme bezüglich Ihres NZXT-Produktes auftreten, wenden Sie sich bitte mit einer detaillierten Problembeschreibung und Ihrem Kaufbeleg an service@nzxt.com.

Ersatzteile können Sie unter support.nzxt.com anfragen. Kommentare und Anregungen senden Sie bitte per designer@nzxt.com an unser Designteam. Vielen Dank, dass Sie ein NZXT-Produkt erworben haben. Weitere Informationen über NZXT erhalten Sie im Internet. NZXT-Webseite: [NZXT.com](https://nzxt.com)



ASSISTENZA E SERVIZIO

In caso di dubbi o problemi con il prodotto NZXT acquistato, non esitate a contattarci utilizzando il nostro sistema di assistenza.

support.nzxt.com

Includere una spiegazione dettagliata del problema e la prova di acquisto. Per commenti e suggerimenti, siete pregati di inviare un messaggio al nostro team di progettisti, all'indirizzo: designer@nzxt.com. Infine, vogliamo ringraziarvi del vostro supporto con l'acquisto di questo prodotto. Per altre informazioni su NZXT, visitate il nostro sito. Sito NZXT: [NZXT.com](https://nzxt.com)

ASSISTÊNCIA E MANUTENÇÃO

Caso tenha questões ou problemas com o produto NZXT adquirido, não hesite em contactar-nos através do endereço service@nzxt.com fornecendo a explicação detalhada do seu problema e a prova de compra. Poderá solicitar peças de substituição através do endereço support.nzxt.com. Para comentários e sugestões, contacte a nossa equipa de design através do endereço de e-mail, designer@nzxt.com. Obrigado por ter adquirido um produto NZXT. Para mais informações

acerca da NZXT, visite-nos online. Web site da NZXT: [NZXT.com](https://nzxt.com)

СЛУЖБА ПОДДЕРЖКИ И ОБСЛУЖИВАНИЯ

В случае возникновения вопросов или неисправностей в приобретенных вами продуктах NZXT обращайтесь по адресу: service@nzxt.com с подробным описанием проблемы и подтверждением покупки. О наличии запчастей можно узнать, обратившись по адресу: support.nzxt.com. Замечания и предложения отправляйте в адрес нашей группы разработчиков: designer@nzxt.com. Благодарим вас за покупку продукта NZXT. Более подробная информация о компании NZXT представлена на наших веб-сайтах. Веб-сайт NZXT: [NZXT.com](https://nzxt.com)



지원 및 서비스

구입한 NZXT 제품과 관련하여 질문 또는 문제가 있을 경우, 당사의 지원 시스템 (support.nzxt.com)을 사용하여 문의하십시오.

문제를 자세히 기술하고 구매 증빙을 제출하십시오. 의견 또는 제안 사항이 있을 경우 당사 설계 팀에 designer@nzxt.com으로 이메일을 보내십시오. 마지막으로 이 제품을 구입하여 당사를 응원해 주셔서 감사합니다. NZXT에 대해 자세히 알려면 온라인으로 방문하십시오. NZXT 웹사이트: [NZXT.com](https://nzxt.com)

サポートおよびサービス

購入されましたNZXTの製品に関するご質問または問題は、問題の詳細および購入の証明を添えて、ご遠慮なくservice@nzxt.comまでご連絡ください。交換部品はsupport.nzxt.comまでお尋ねください。ご意見およびご提案は弊社設計チーム、designer@nzxt.comまでメールを送信してください。NZXT製品をご購入いただきましてありがとうございます。NZXTに関する詳細は、インターネット上のウェブサイトをご覧ください。NZXT ウェブサイト: [NZXT.com](https://nzxt.com)

支持和服务

如果有任何疑问或者在使用 NZXT 产品的过程中遇到任何问题,欢迎联络 service@nzxt.com,联络时请提供关于问题的详细说明及购买凭证。您可以向 support.nzxt.com 查询更换部件。如有任何意见或建议,欢迎致信我们的设计团队,电子邮件地址是 designer@nzxt.com。感谢您购买 NZXT 产品。有关 NZXT 的更多信息,请造访我们的在线网站。NZXT 网站: [NZXT.com](https://nzxt.com)

支援和服務

如果在使用NZXT 產品的過程中有遇到任何問題或疑問，歡迎聯繫 service@nzxt.com，並請提供問題的詳細敘述及購買證明。您可以透過 support.nzxt.com 查詢更換部件。如有任何意見或建議，歡迎來信與設計團隊聯繫 designer@nzxt.com。最後，感謝您購買 NZXT 產品。有關 NZXT 的更多信息，請訪問我們的網站。NZXT 網站: [NZXT.com](https://nzxt.com)



FCC COMPLIANCE STATEMENT

This equipment has been tested and found to comply with the limits for a Class B digital device, pursuant to Part 15 of the FCC Rules. These limits are designed to provide reasonable protection against harmful interference in a residential installation. This equipment generates, uses, and can radiate radio frequency energy and, if not installed and used in accordance with the instructions, may cause harmful interference to radio communications. However, there is no guarantee that interference will not occur in a particular installation. If this equipment does cause harmful interference to radio or television reception, which can be determined by turning the equipment off and on, the user is encouraged to try to correct the interference by one or more of the following measures:

- Reorient or relocate the receiving antenna
- Increase the separation between the equipment and the receiver
- Connect the equipment onto an outlet on a circuit different from that to which the receiver is connected
- Consult the dealer or an experienced radio/TV technician for help

Shielded interconnect cables and a shielded AC power cable must be employed with this equipment to ensure compliance with the pertinent RF emission limits governing this device. Changes or modifications not expressly approved by the system's manufacturer could void the user's authority to operate the equipment.

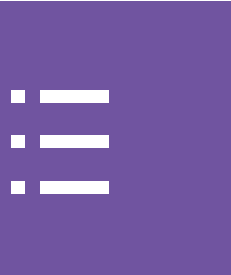

DECLARATION OF CONFORMITY

I. THIS DEVICE COMPLIES WITH PART 15 OF THE FCC RULES. OPERATION IS SUBJECT TO THE FOLLOWING CONDITIONS:

- This device may not cause harmful interference
- This device must accept any interference received, including interference that may cause undesired operation.

II. THIS DEVICE IS IN CONFORMITY WITH THE FOLLOWING EC/EMC DIRECTIVES:

EN 55022	Limits and methods of measurement of radio disturbance characteristics of information technology equipment
EN 61000-3-2	Disturbance in supply systems caused
EN 61000-3-3	Disturbance in supply systems caused by household appliances and similar electrical equipment "Voltage fluctuations"
EN 55024	Information technology equipment-immunity characteristics - Limits and methods of measurement
EN 60950	Safety for information technology equipment including electrical business Equipment

III. CE CONFORMITY

NZXT Inc, declares that this device is in compliance with the essential safety requirements and other relevant provisions set out in the European Directive.

IV. CANADIAN DEPARTMENT OF COMMUNICATIONS

This class B digital apparatus meets all requirements of the Canadian Interference-causing Equipment Regulations.
Cet appareil numérique de la classe B respecte toutes les exigences du Règlement sur le matériel brouilleur du Canada.

V. KOREAN CERTIFICATION MARK

Includes a KCC (Korean Communications Commission) certification number: KCC-R-R-ZXT-N7Z69XT.



5.4 BATTERY INFORMATION

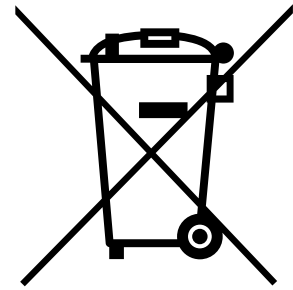

EUROPEAN UNION

Batteries, battery packs, and accumulators should not be disposed of as unsorted household waste. Please use the public collection system to return, recycle, or treat them in compliance with the local regulations.

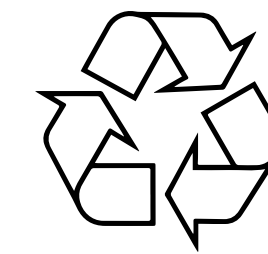

CALIFORNIA, USA

The button cell battery may contain perchlorate material and requires special handling when recycled or disposed of in California. For further information please visit: <http://www.dtsc.ca.gov/hazardouswaste/perchlorate>

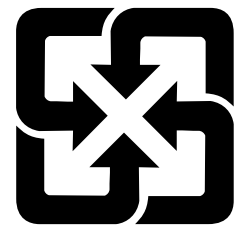

TAIWAN

For better environmental protection, waste batteries should be collected separately for recycling or special disposal.



CAUTION

- There is a risk of explosion, if battery is incorrectly replaced. Replace with the same or equivalent type recommended by the manufacturer.



ENGLISH

To protect the global environment and as an environmentalist, NZXT must remind you that...

Under the European ("EU") Directive on Waste Electrical and Electronic Equipment, Directive 2012/19/EU, effective February 14, 2014, products of "electrical and electronic equipment" cannot be discarded as municipal wastes, and manufacturers of covered electronics must take back such products at the end of their useful life. NZXT will comply with the product take back requirements at the end-of-life of NZXT products that are sold within the EU. You can return these products to local collection points.

ESPAÑOL

NZXT como empresa comprometida con la protección del medio ambiente, recomienda:

Bajo la directiva 2012/19/EU de la Unión Europea en materia de desechos y/o equipos electrónicos, con fecha de rigor desde el 14 de febrero de 2014, los productos clasificados como "eléctricos y equipos electrónicos" no pueden ser depositados en los contenedores habituales de su municipio, los fabricantes de equipos electrónicos, están obligados a hacerse cargo de dichos productos al término de su período de vida. NZXT estará comprometido con los términos de recogida de sus productos vendidos en la Unión Europea al final de su periodo de vida. Usted debe depositar estos productos en el punto limpio establecido por el ayuntamiento de su localidad o entregar a una empresa autorizada para la recogida de estos residuos.



FRANÇAIS

En tant qu'écologiste et afin de protéger l'environnement, NZXT tient à rappeler ceci...

Au sujet de la directive européenne (EU) relative aux déchets des équipement électriques et électroniques, directive 2012/19/EU, prenant effet le 14 février 2014, que les produits électriques et électroniques ne peuvent être déposés dans les décharges ou tout simplement mis à la poubelle. Les fabricants de ces équipements seront obligés de récupérer certains produits en fin de vie. NZXT prendra en compte cette exigence relative au retour des produits en fin de vie au sein de la communauté européenne. Par conséquent vous pouvez retourner localement ces matériels dans les points de collecte.

DEUTSCH

Hinweis von NZXT zur Erhaltung und Schutz unserer Umwelt
Gemäß der Richtlinie 2012/19/EU über Elektro- und Elektronik-Altgeräte dürfen Elektro- und Elektronik-Altgeräte nicht mehr als kommunale Abfälle entsorgt werden. NZXT hat europaweit verschiedene Sammel- und Recyclingunternehmen beauftragt, die in die Europäische Union in Verkehr gebrachten Produkte, am Ende seines Lebenszyklus zurückzunehmen. Bitte entsorgen Sie dieses Produkt zum gegebenen Zeitpunkt ausschliesslich an einer lokalen Altgerätesammelstelle in Ihrer Nähe.

ITALIANO

Per salvaguardare l'ambiente globale, NZXT ricorda che:
La Direttiva Europea (UE) RAEE, in materia di rifiuti costituiti da apparecchiature elettriche ed elettroniche (Direttiva 2012/19/UE, in vigore dal 14 febbraio 2014), le apparecchiature elettriche ed elettroniche non possono essere smaltite tra i rifiuti municipali e i produttori di apparecchiature elettroniche sono tenuti a ritirare tali prodotti alla fine del ciclo di vita utile. NZXT è conforme ai requisiti inerenti al ritiro a fine vita dei prodotti NZXT venduti nell'UE. Questi prodotti devono essere conferiti nei centri di raccolta locali.



PORTUGUÊS

Para proteger o meio ambiente global e como um ambientalista, a NZXT lembra você de que...

Sob a Diretiva Europeia (“EU”) sobre Equipamentos Eletroeletrônicos Residuais, Diretiva 2012/19/EU, em vigor desde 14 de fevereiro de 2014, produtos de “equipamentos eletroeletrônicos” não podem ser descartados como lixo municipal e os fabricantes de eletrônicos cobertos devem receber de volta tais produtos no fim de sua vida útil. A NZXT cumprirá os requisitos de recolhimento do produto ao fim da vida útil dos produtos da NZXT vendidos dentro da UE. Você pode devolver esses produtos aos pontos de coleta locais.

РУССКИЙ

В целях поддержки движения защитников окружающей среды и охраны глобальной окружающей среды компания NZXT напоминает вам...
В соответствии с требованиями Директивы по утилизации электрического и электронного оборудования ЕС 2012/19/EU от 14 февраля 2014 г. продукты, являющиеся «электрическим и электронным оборудованием», должны утилизироваться отдельно от бытовых отходов, и производители оборудования, подпадающего под действие данной директивы, должны принимать такие продукты в случае их возврата в конце срока службы. NZXT будет соблюдать требования к возврату продукта производителю в конце срока службы продуктов NZXT, которые продаются на территории ЕС. Для возврата продуктов производителю созданы специализированные пункты приема.



한국어

지구를 보호하고, 환경에 친화적인 기업인 NZXT는 다음 사항을 안내합니다. 2014년 2월 14일부터 시행되는 Directive 2012/19/EU, 폐전기·전자제품에 관한 유럽연합("EU")의 지침에 따라 "전기·전자제품"은 일반폐기물로서 폐기할 수 없으며, 수명이 다한 제품은 반드시 해당 제품의 제조업체가 회수해야 합니다. NZXT는 유럽 내에서 판매되는 NZXT 제품에 대한 회수 지침을 준수합니다. 수명이 다한 제품은 해당 지역의 회수처에 반납하실 수 있습니다.

日本語

NZXTはかけがえのない地球環境を保護するために、廃電気・電子製品(WEEE)に関する欧州連合(EU)の指令を遵守します。
WEEE指令2012/19/EU(2014年2月14日発効)で定められた通り、EU域内では電気機器・電子機器製品は地方自治体の廃棄物として廃棄できないため、対象となる電子機器メーカーは、製品が耐用年数に達した際に該当製品を引き取る必要があります。NZXTは、EU内で販売されるNZXT製品の耐用年数終了時の製品引き取り要件を遵守します。ユーザーの方におかれましては、該当製品を最寄りの回収場所にお出しいただけますよう、お願いいたします。

简体中文

作为一家环保型企业，为保护全球环境，NZXT 提醒您.....
根据 2014 年 2 月 14 日生效的欧洲 ("EU") 废弃电子电气设备指令——第 2012/19/EU 号指令的规定，“电气和电子设备”产品不可作为市政废物丢弃，相关电子产品的制造商须在此类产品使用寿命结束时将其收回。对于 NZXT 在欧盟地区售出的 NZXT 产品报废时，NZXT 将遵循该产品回收要求。您可以将这些产品送至当地的回收点。

中文

為保護全球環境，NZXT 提醒您...
依據 2014 年 2 月 14 日生效的歐盟 ("EU") 廢棄電子電氣設備指令第 2012/19 / EU 號指令規定，「電氣和電子設備」產品不得視為都市廢棄物丟棄，相關的電子產品製造商必須在產品使用壽命結束時將產品回收。對於歐盟境內銷售的 NZXT 產品，NZXT 將在產品使用壽命結束時，按照產品回收要求收回產品。您可以將這些產品送到當地的回收點。

5.6 REVISION HISTORY



Version 1.2, 2022/01/26