

NZXT

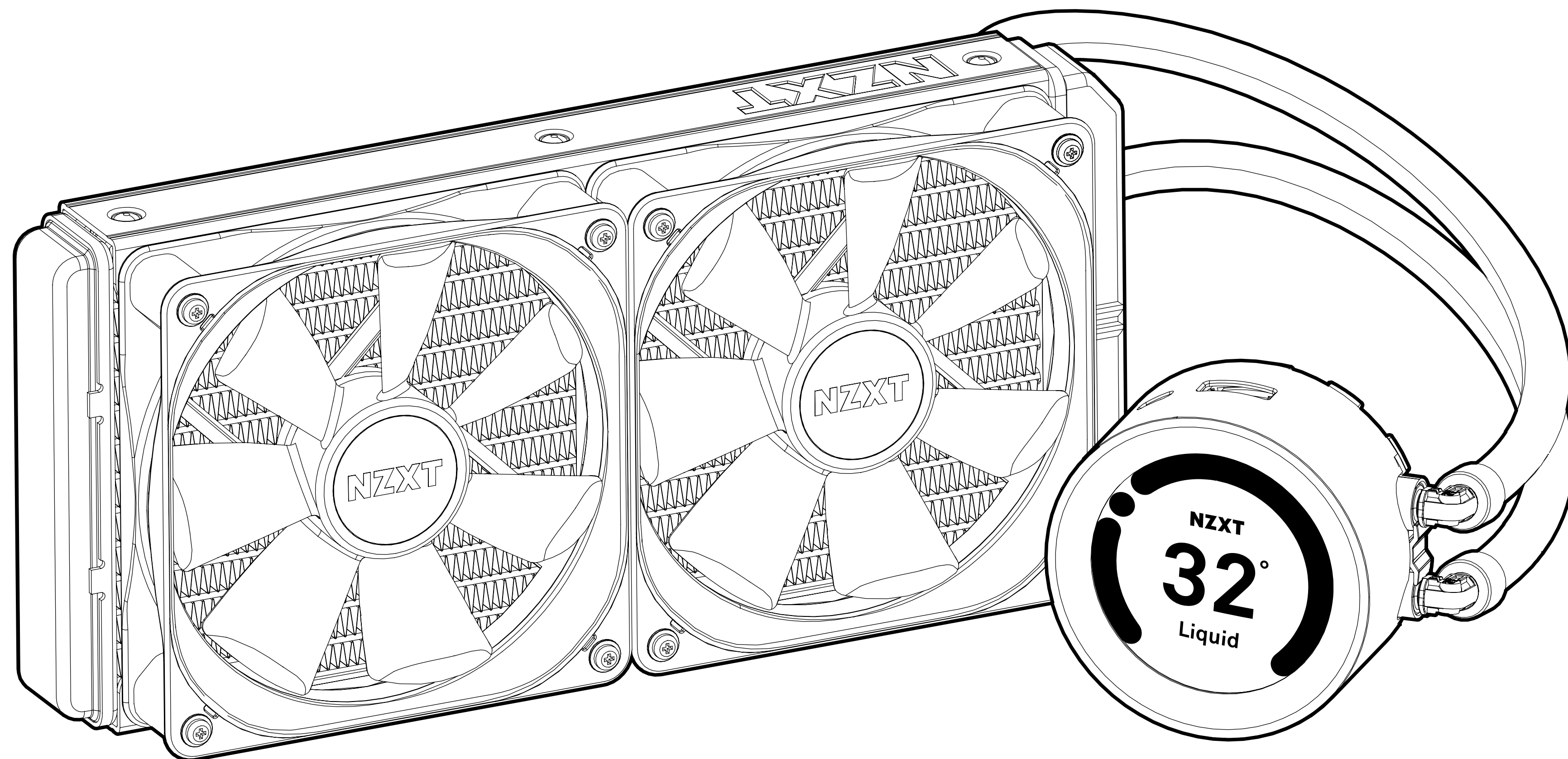

KRAKEN Z SERIES

SISTEMA DE REFRIGERAÇÃO LÍQUIDA COM ECRÃ LCD

1. COMPONENTES 02

2. PREPARAÇÃO 05

3. INSTALAÇÃO 13

4. DOWNLOAD DO NZXT CAM 25

5. APÊNDICE A-1

1. COMPONENTES



A. Kraken Z53 / Z63 / Z73

x1

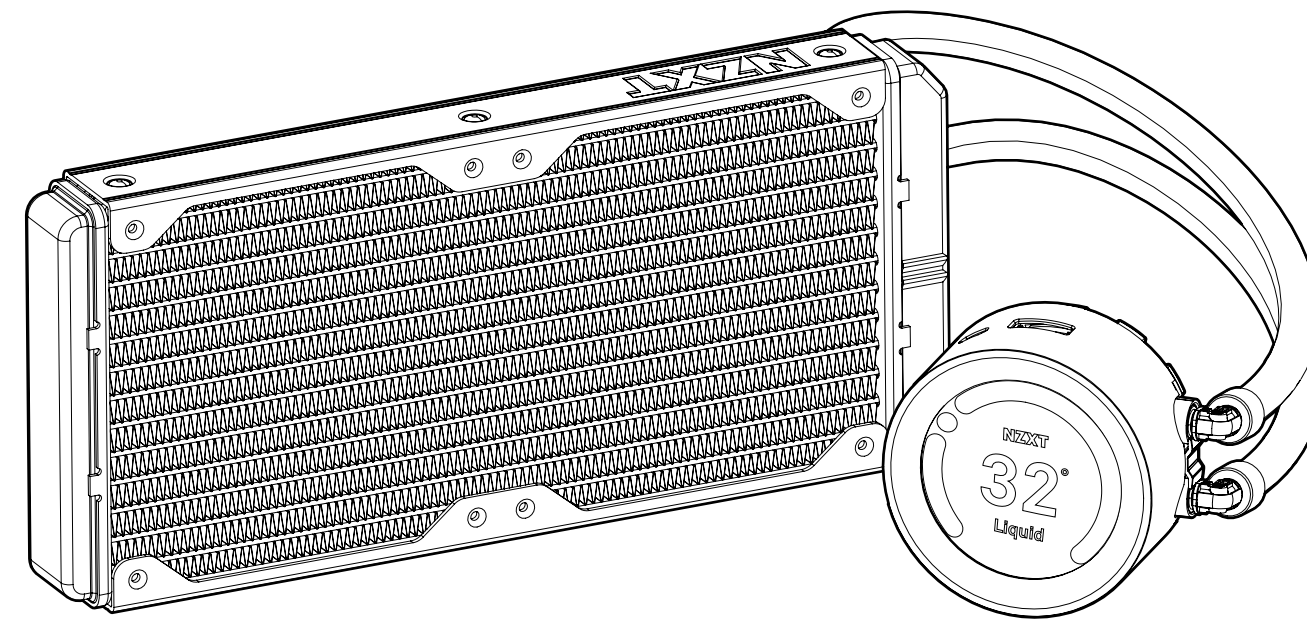

C. Suporte de retenção AMD

x1

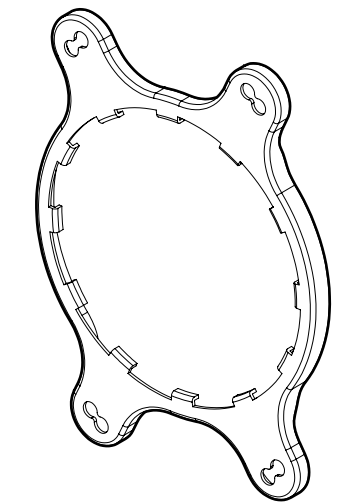

B. Suporte de retenção Intel (pré-instalado)

x1

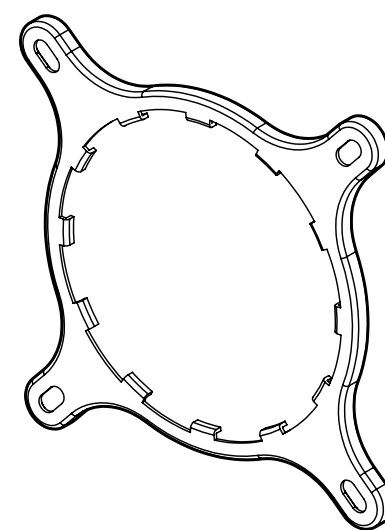

D. Backplate Intel

x1

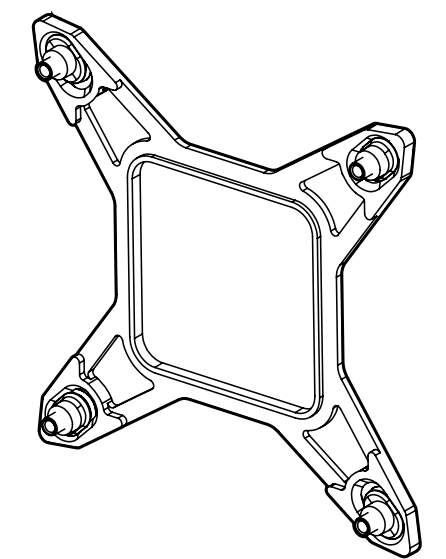



E. Espaçador para soquete Intel 1200/115X/1366

x4

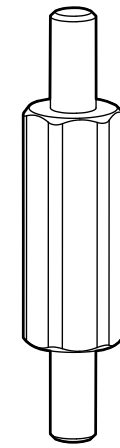

F. Espaçador para soquete Intel 1700

x4

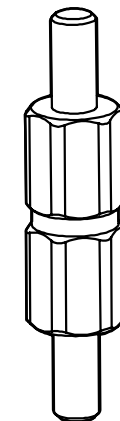

G. Espaçador AMD

x4

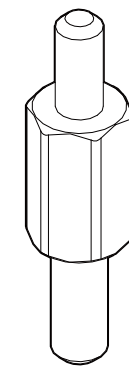

H. Manga AMD

x4

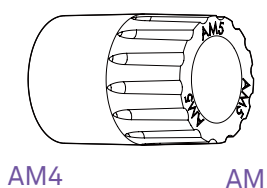

I. Parafuso do fan de 30 mm UNC 6-32

Z53 - x16, Z63 - x16, Z73 - x12

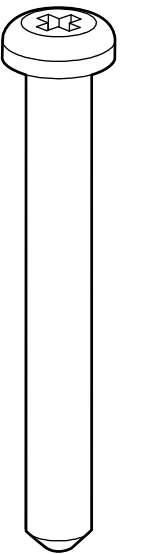

J. Parafuso de 5 mm UNC 6-32

Z53 - x8, Z63 - x8, Z73 - x12

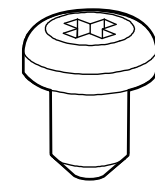

K. Arruela

Z53 - x16, Z63 - x16, Z73 - x24

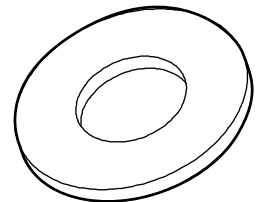

L. Parafuso-borboleta

x4

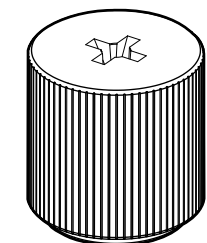



M. Jogo de cabos do tipo breakout

x1

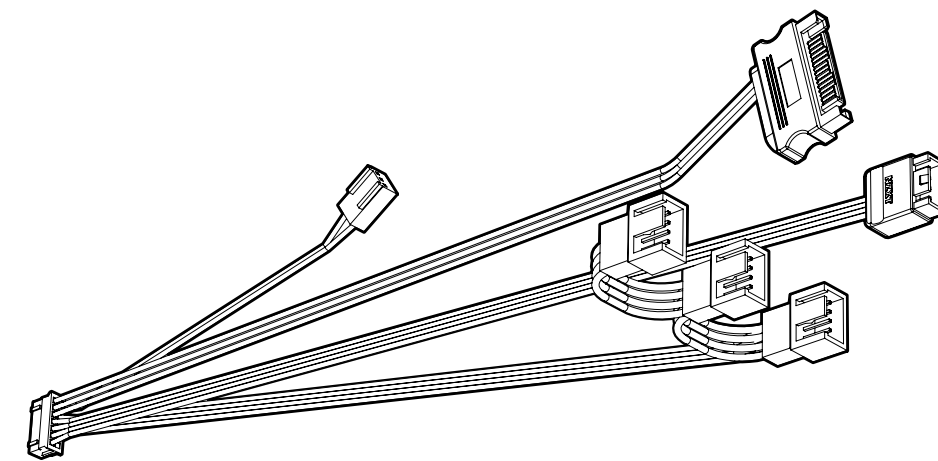

N. Cabo microUSB

x1

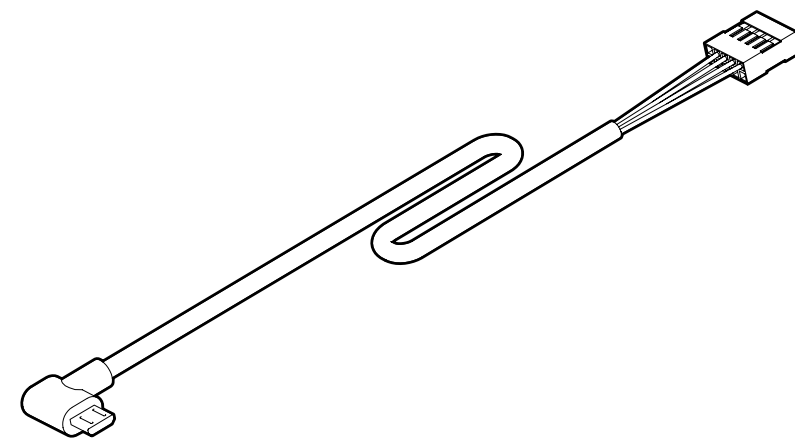

O. Fan Aer P

Z53 - x2 120MM, Z63 - x2 140MM,
Z73 - x3 120MM

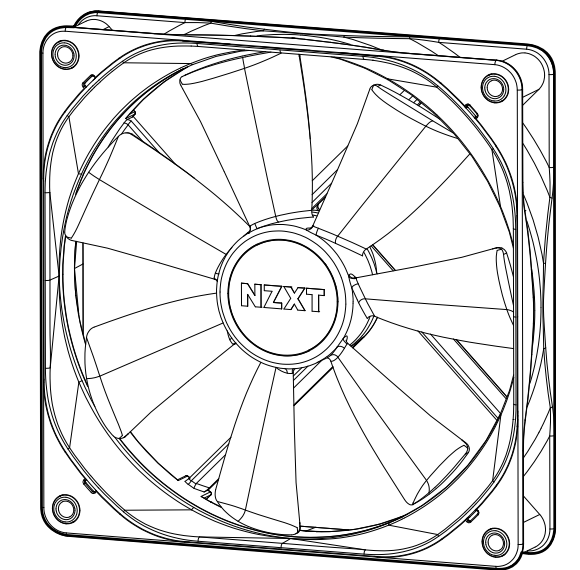

2. PREPARAÇÃO

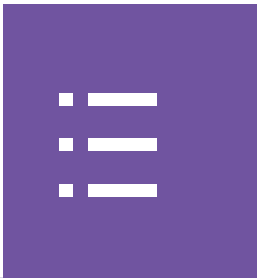

2.1 Preparação - Intel LGA 1700/1200/115X06

2.2 Preparação - Intel AMD.....09

2.1 PREPARAÇÃO - INTEL LGA 1700&1200/115X

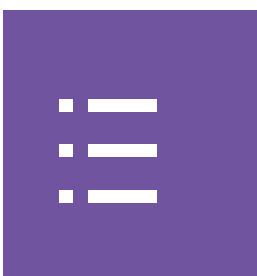

STEP 1 - PREPARAÇÃO DA BACKPLATE

Mova todas as quatro corrediças na backplate Intel para as posições mais internas para o Soquete 115X ou as posições mais externas para o Soquete 1700.

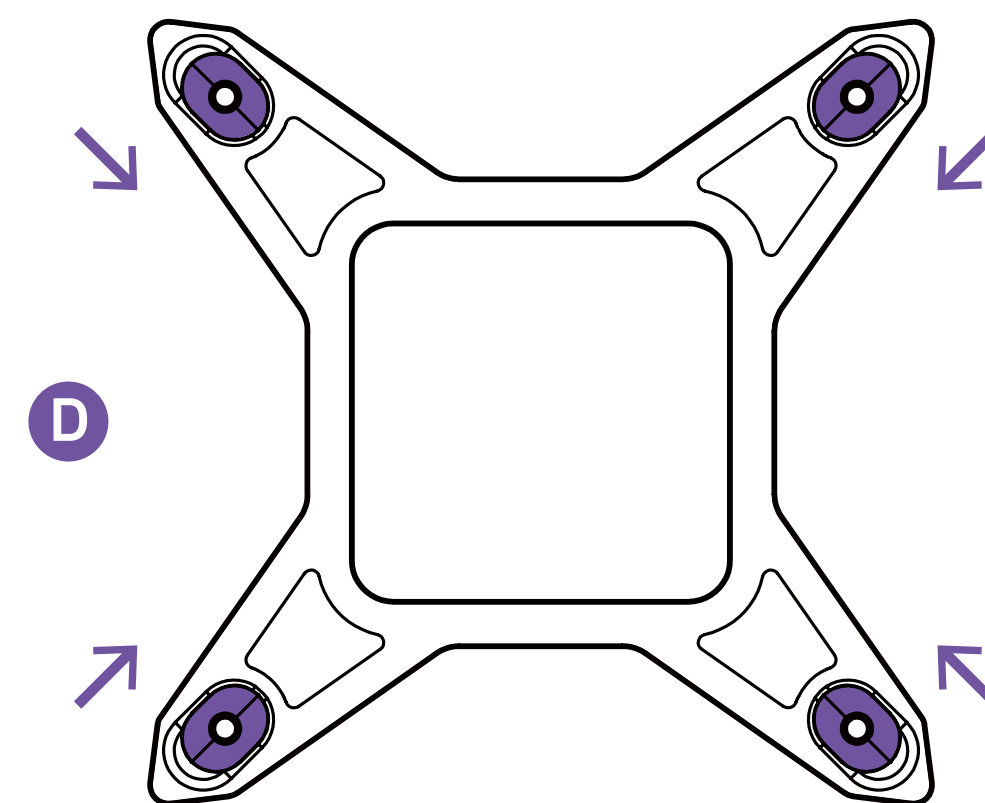

SOCKET 1200/115X

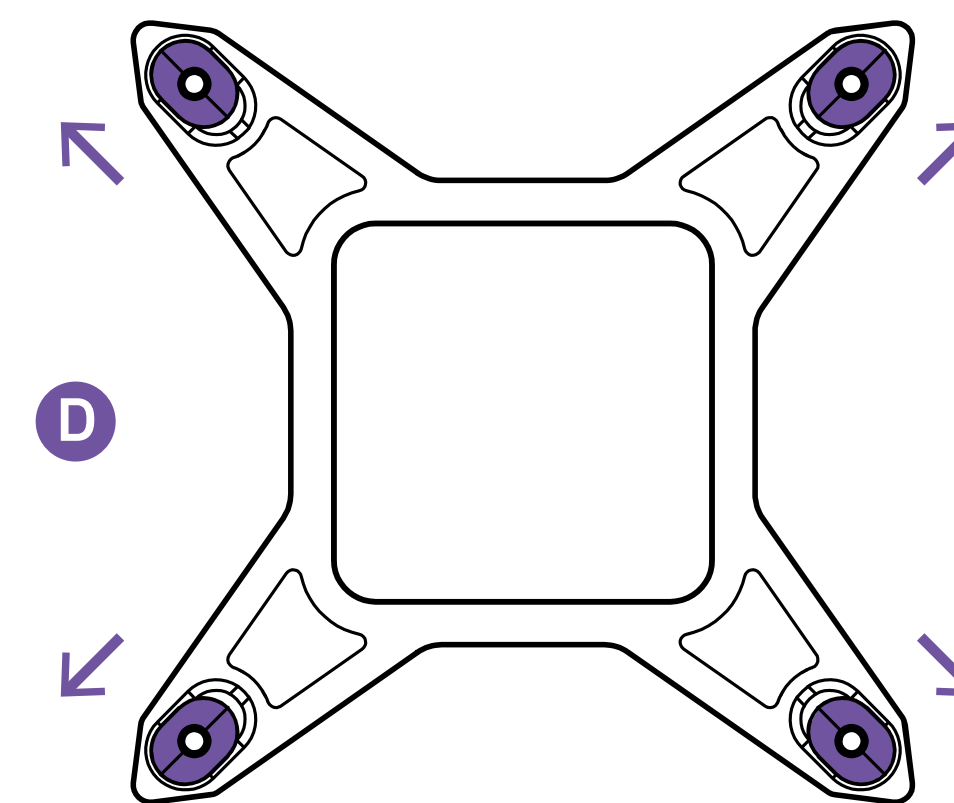

SOCKET 1700



STEP 2 - INSTALAÇÃO DA BACKPLATE

Instale a backplate Intel na parte traseira da placa-mãe conforme orientado na imagem. As corredeiras devem encaixar nos furos de montagem e a backplate do soquete de CPU deve encaixar dentro do recorte da backplate Intel.

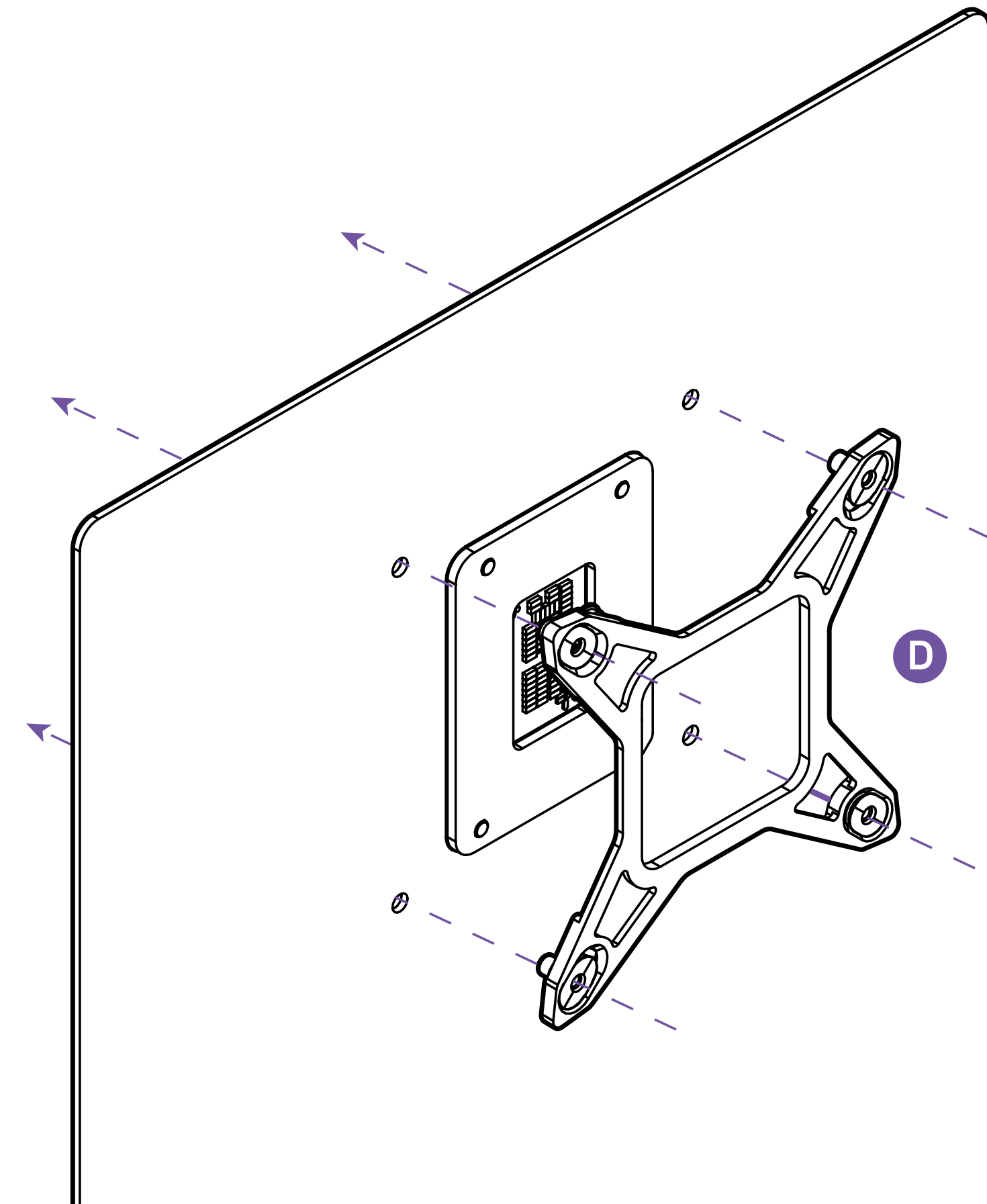



STEP 3 - INSTALAÇÃO DOS SEPARADORES

Pela frente da placa-mãe, instale os quatro separadores de Soquete 1700/1200/115X.

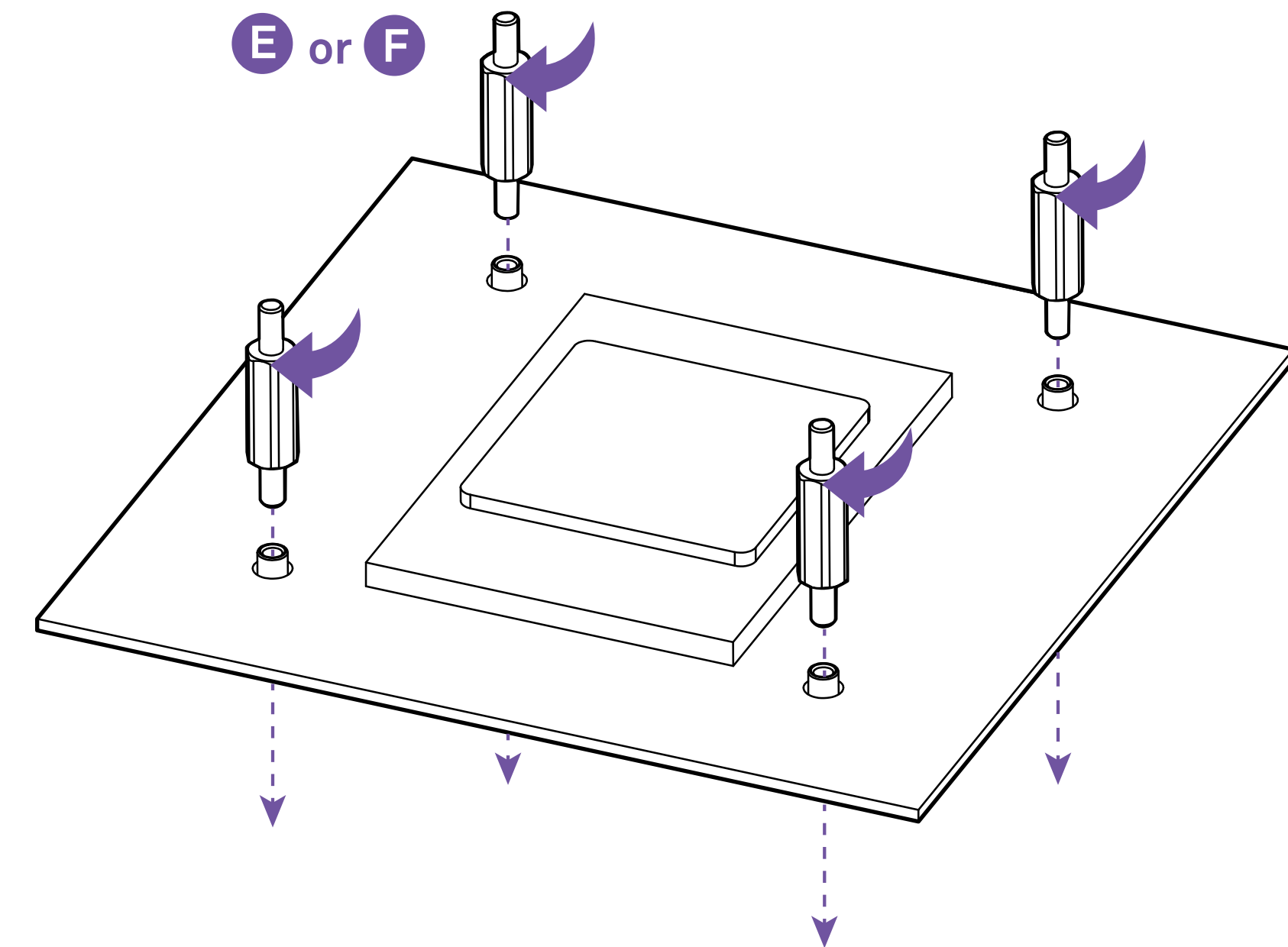



STEP 1

Remova o suporte de montagem AMD de série e mantenha a placa de suporte original na traseira da placa principal.

 PARA O SOCKETTR4, VÁ PARA AMD – ETAPA 4

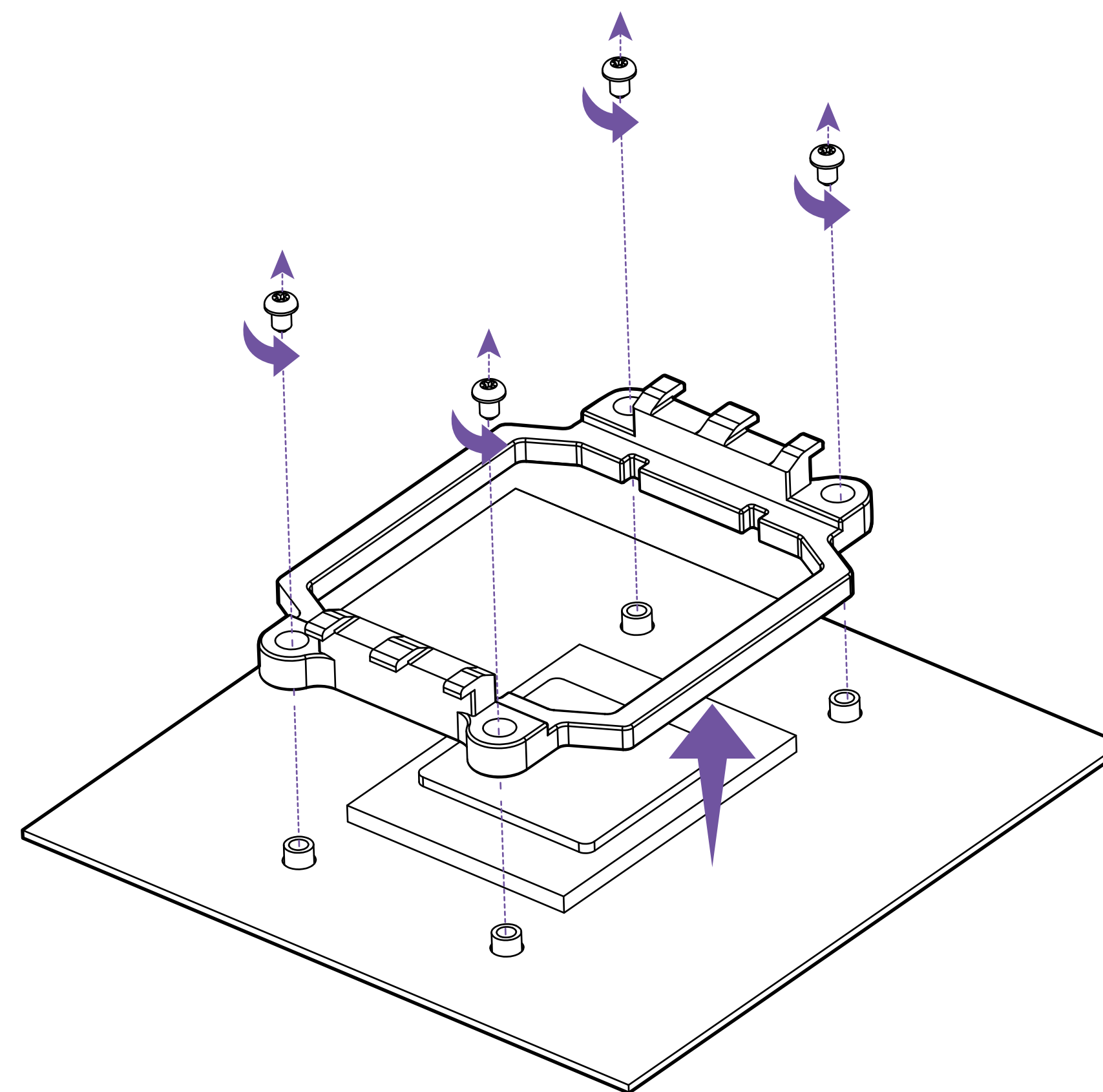



STEP 2

A partir da parte frontal da motherboard, instalar as quatro mangas AMD. Dependendo do encaixe que tem, verifique que orienta as mangas em conformidade, com o nome do encaixe voltado para cima.

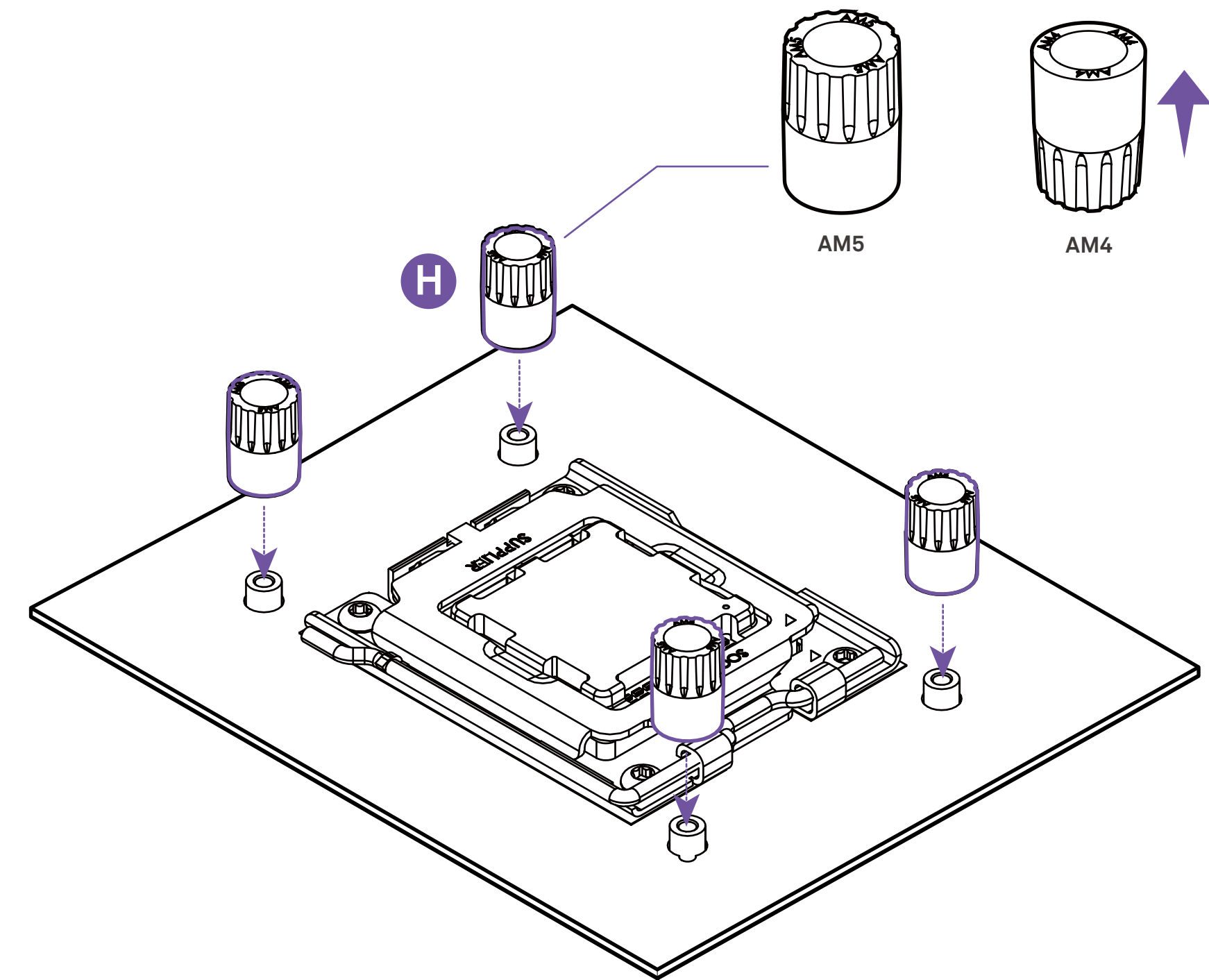



STEP 3

A partir da parte frontal da motherboard, instalar os quatro parafusos afastadores AMD.

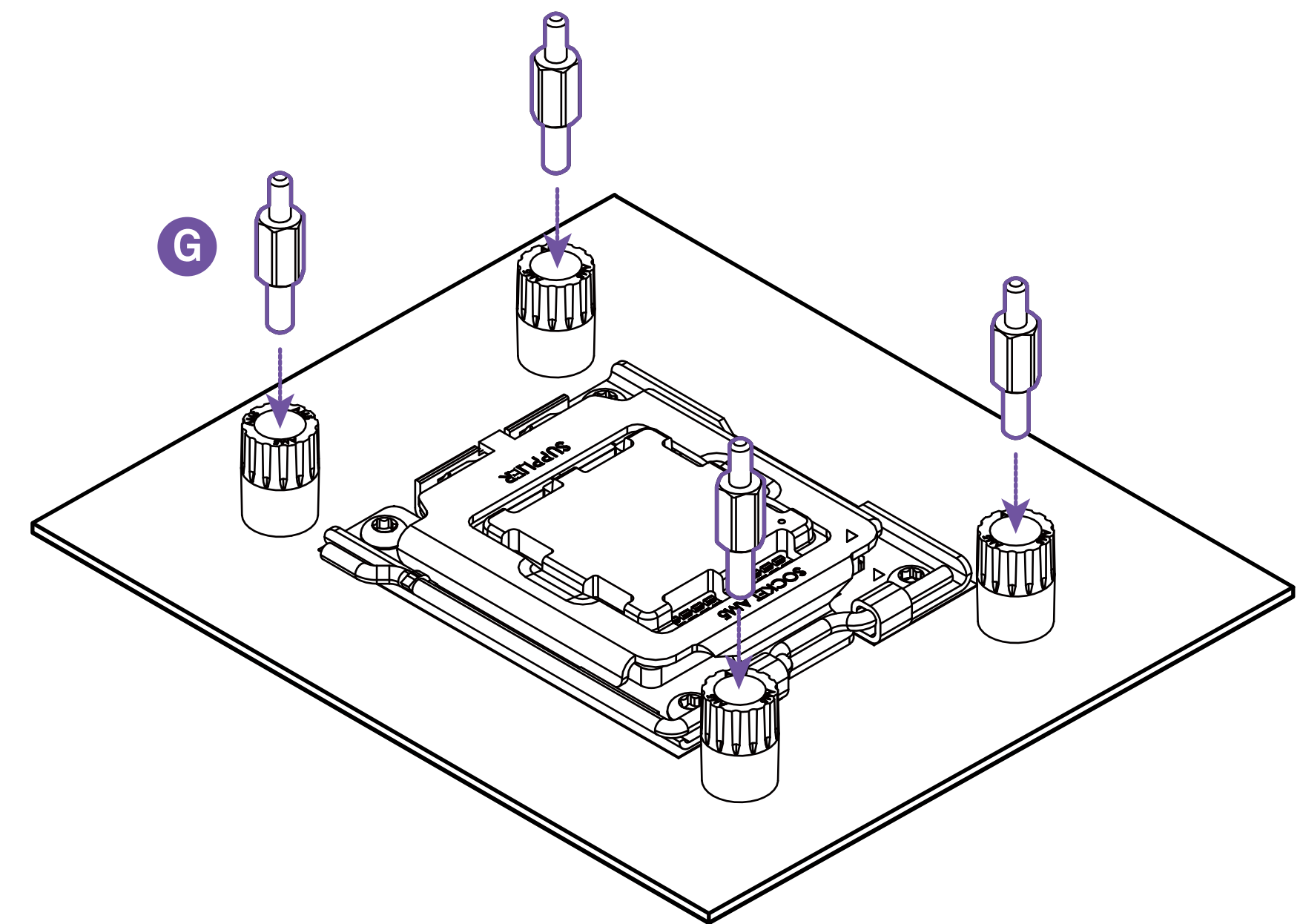



STEP 4 - TROCA DO SUPORTE DE RETENÇÃO

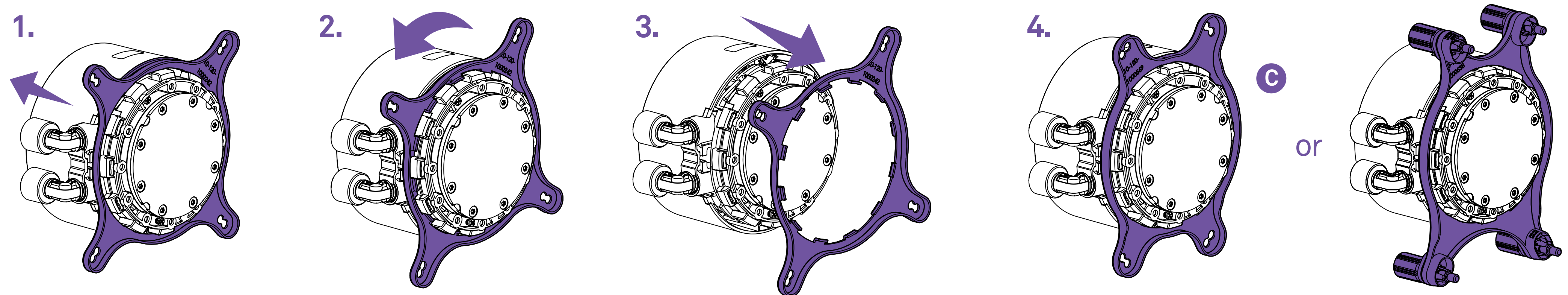

1. Pressione e gire o suporte de retenção Intel firmemente em direção à bomba.
2. Gire o suporte de retenção Intel no sentido anti-horário para liberar.
3. Puxe o suporte de retenção Intel para fora.
4. Siga estas etapas na ordem inversa para instalar o suporte de retenção AMD na bomba. Para o SocketTR4, instale o suporte de retenção do AMD SocketTR4 incluído dentro da caixa de varejo da CPU Threadripper.

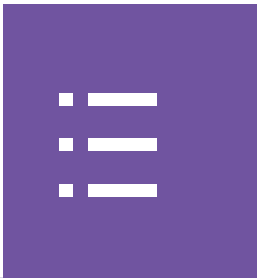

3.1 Instalação da bomba -
Orientação da bomba 14

3.2 Instalação da bomba - INTEL/AMD AM5/AM4 15

3.3 Instalação da bomba - AMD TR4 16

3.4 Montagem do radiador e dos fans 17

3.5 Alimentação dos fans 20

3.6 Conexão do tacômetro da bomba..... 21

3.7 Conexão do cabo de energia SATA 22

3.8 Conexão do cabo USB 23

3.9 Conexão do LED RGB para
controle de iluminação 24

3.1 INSTALAÇÃO DA BOMBA - ORIENTAÇÃO DA BOMBA

KRAKEN Z SERIES



A orientação do visor pode ser ajustada com o CAM em incrementos de 90°. Dependendo de sua placa-mãe, você pode definir a orientação do tubo da bomba conforme suas necessidades.

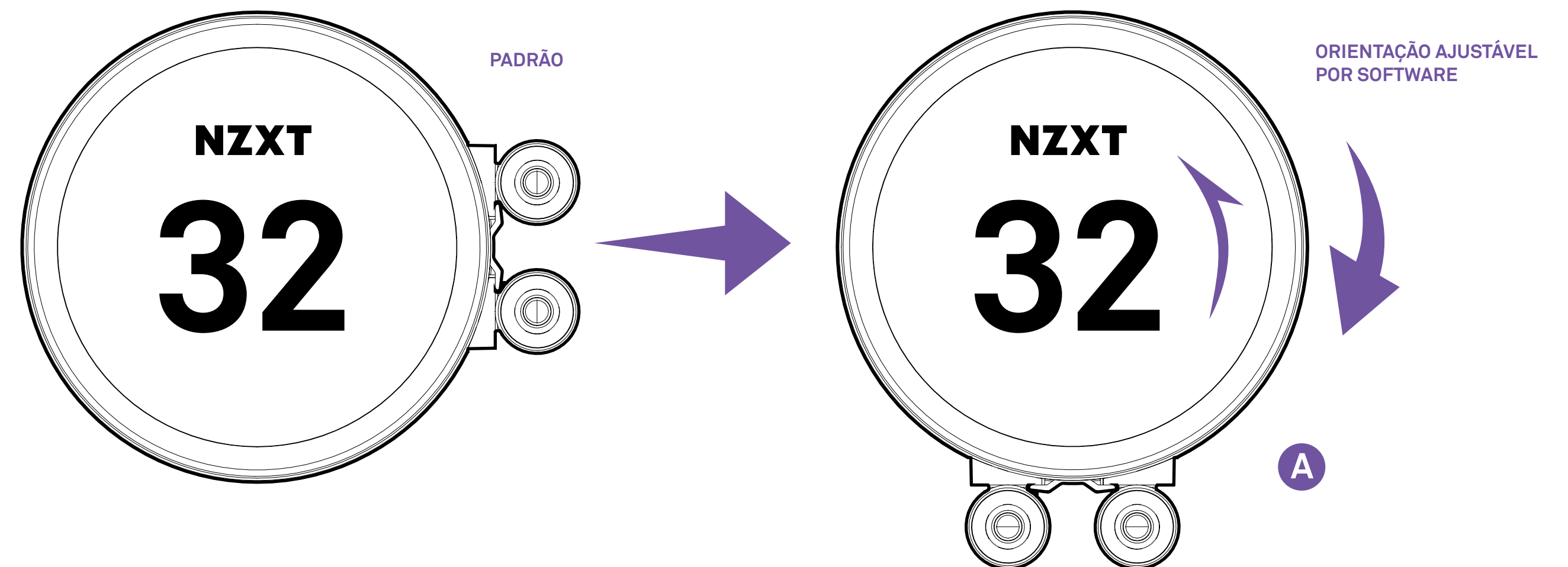

3.2 INSTALAÇÃO DA BOMBA - INTEL/AMD AM5/AM4



Coloque a bomba com o suporte de retenção na CPU.
Garanta que os separadores encaixem-se nos furos no suporte, aplique firmemente as porcas-borboleta.

INTEL

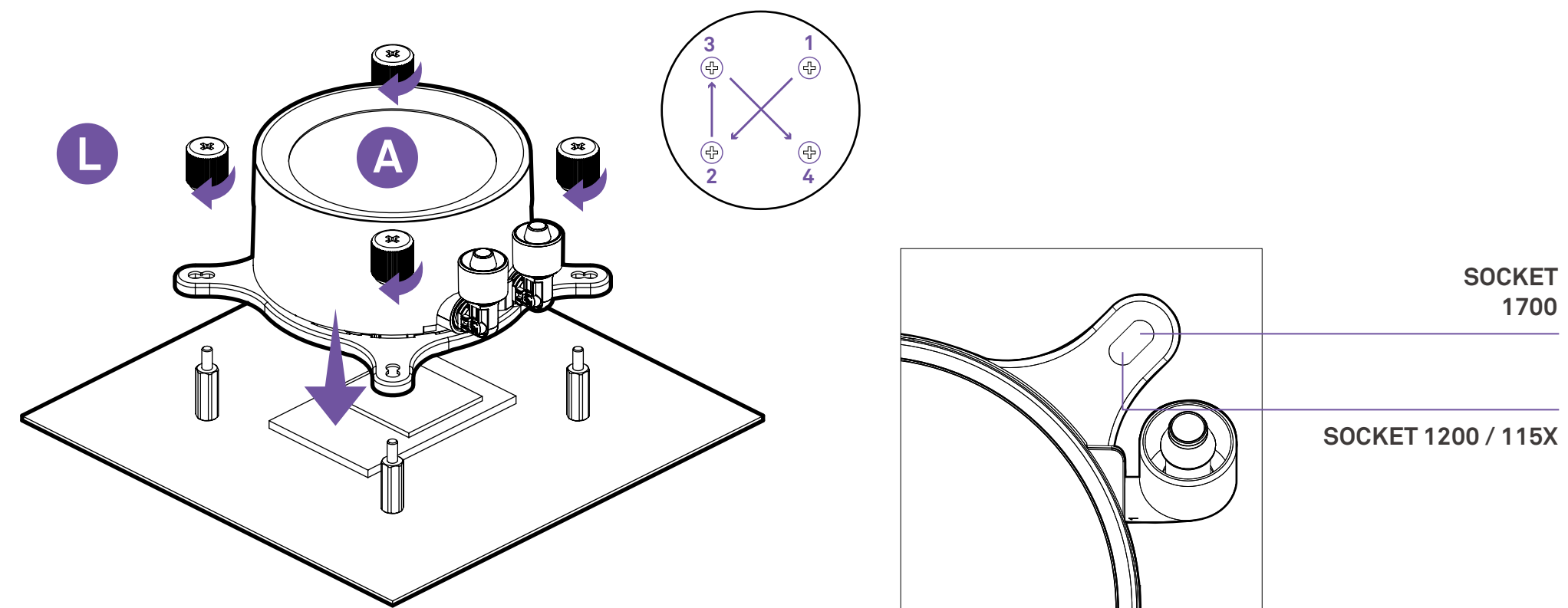

AMD AM5/AM4

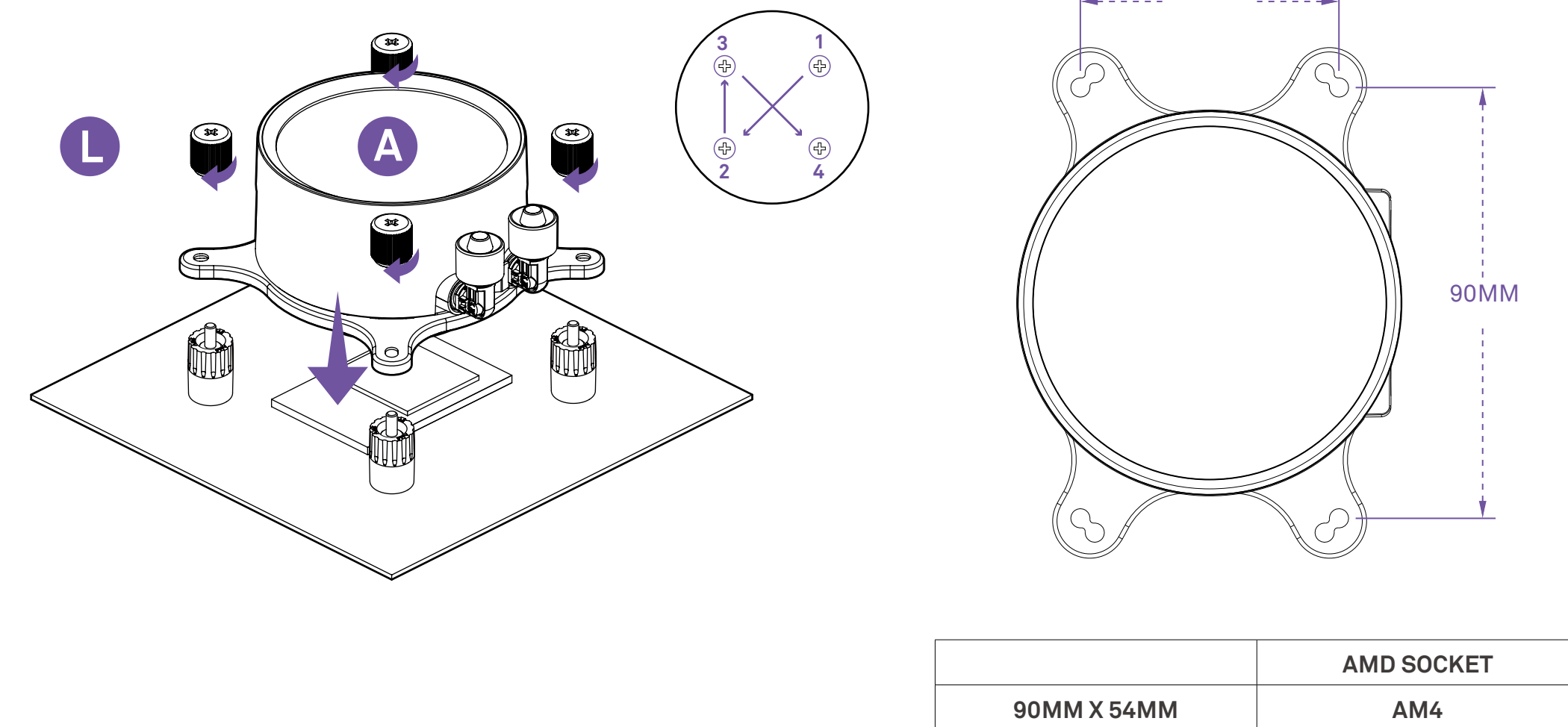

3.3 INSTALAÇÃO DA BOMBA - AMD TR4



Coloque a bomba com o suporte de retenção na CPU. Os furos do parafuso SocketTR4 têm um lado curto e um lado longo. Garanta que os quatro parafusos estejam alinhados e aperte-os em sequência de 1 a 4.

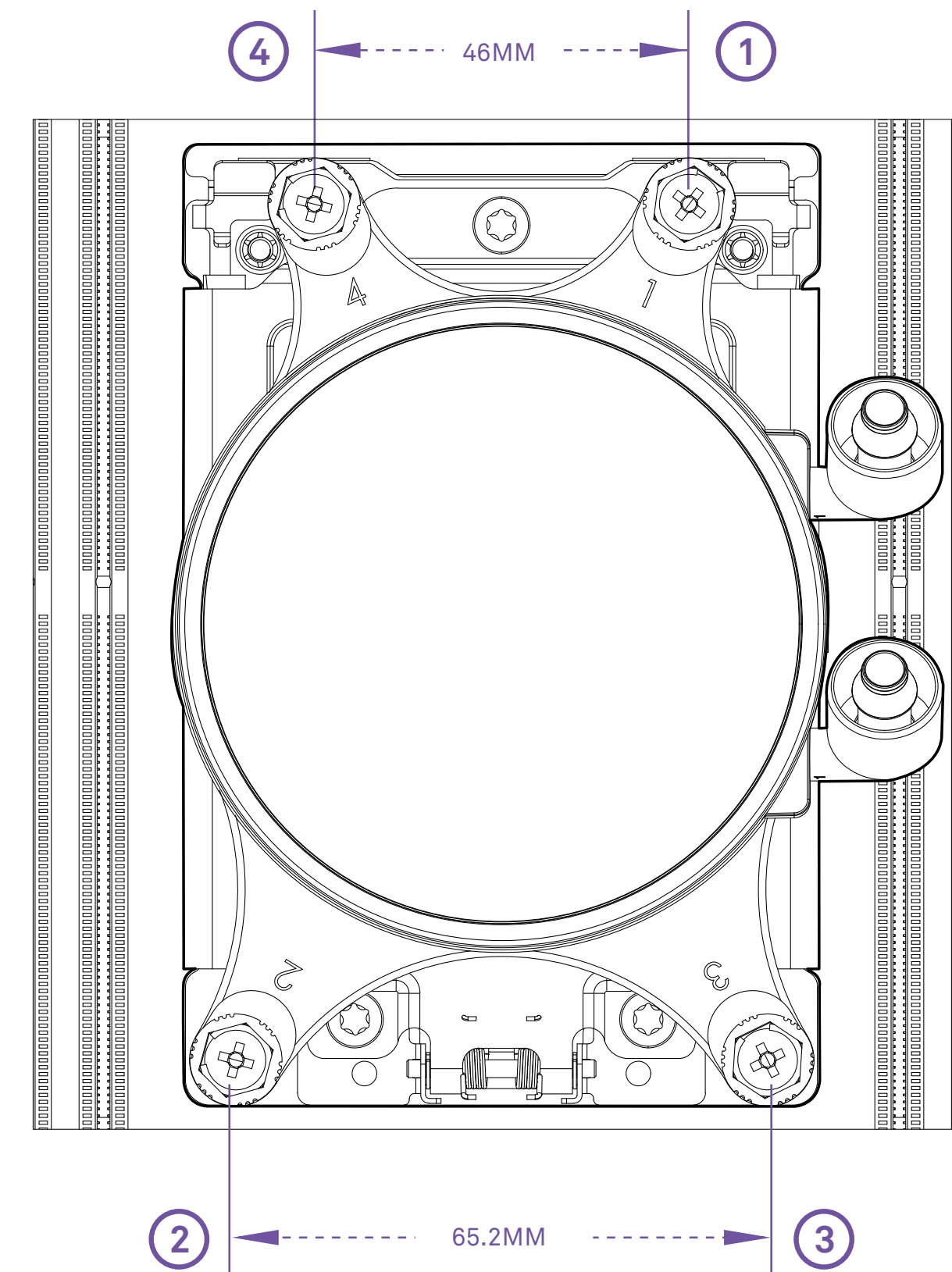



Dependendo da configuração de montagem do radiador, use os parafusos adequados para montar os radiadores:

- MONTAGEM DIRETA
- MONTAGEM INDIRETA

OBSERVAÇÃO

- Sempre use arruelas para prevenir danos.



MONTAGEM DIRETA

Para uma montagem em que o radiador encaixe-se diretamente na caixa, instale os fans primeiro usando os parafusos e as arruelas de 30 mm. Use os parafusos e arruelas de caixa de 5 mm para montar o radiador.

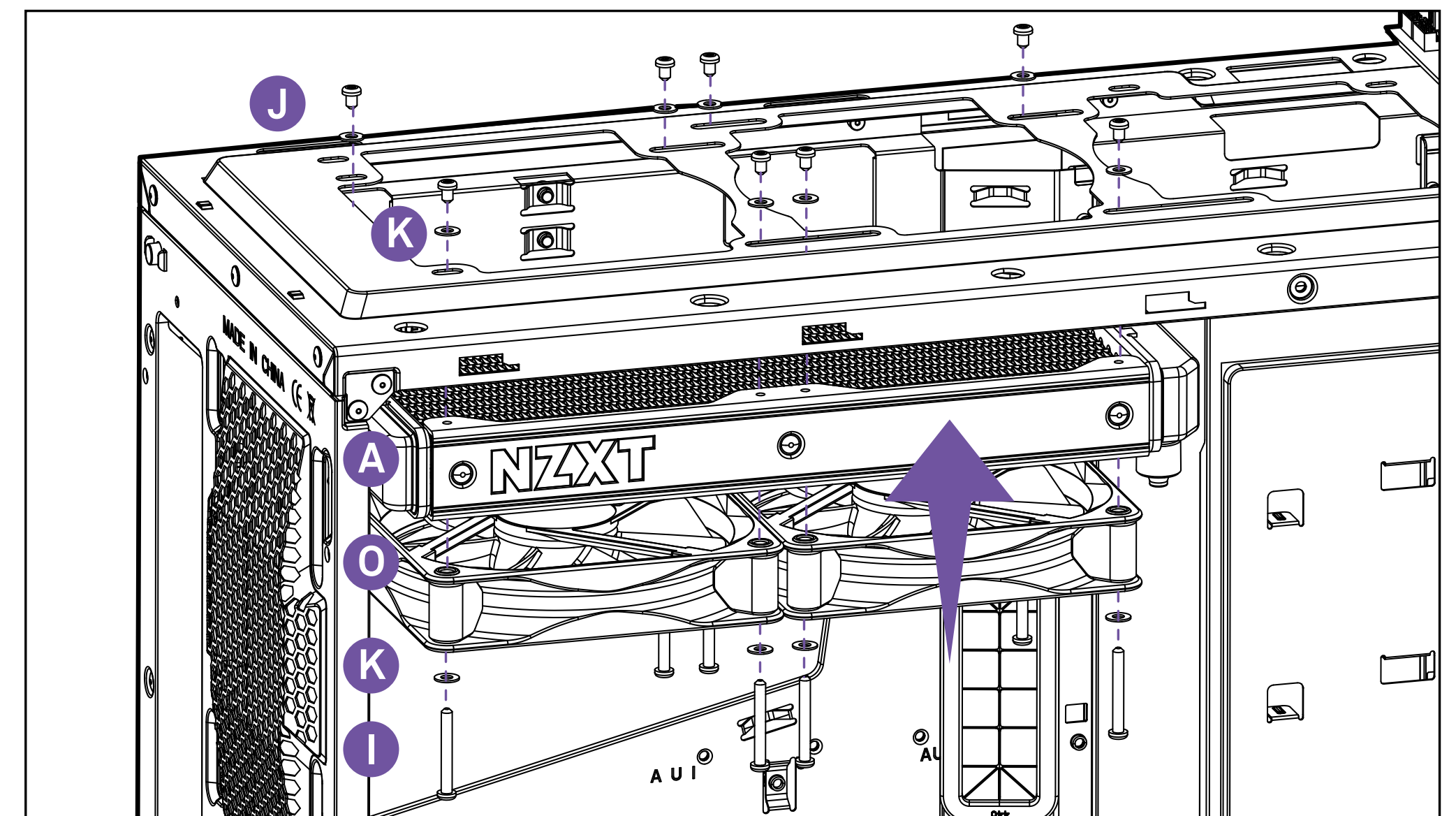



MONTAGEM INDIRETA

Para montagem em que os fans encaixem-se entre o radiador e o chassi, use parafusos e arruelas de 30 mm para a montagem.

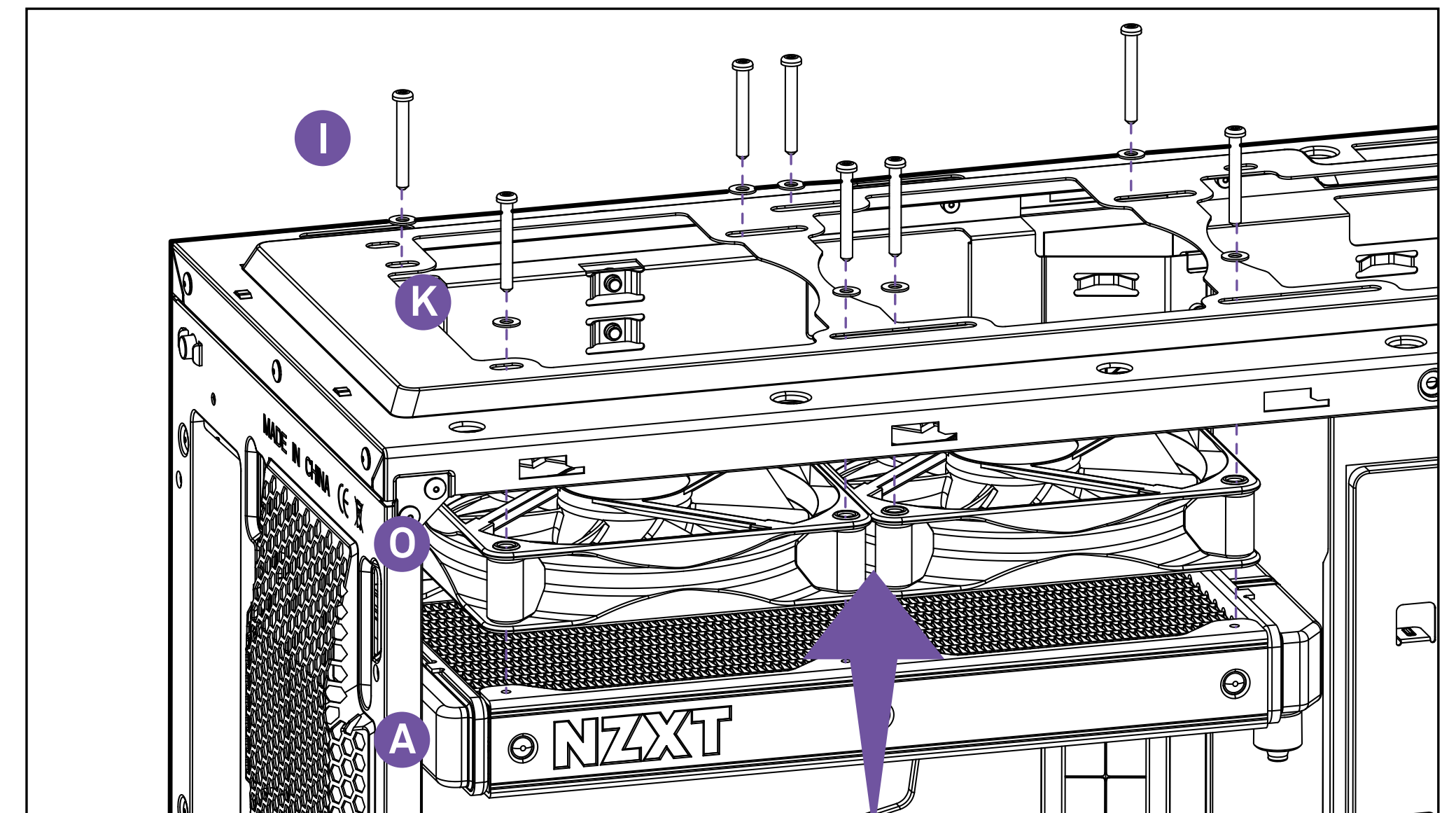

3.5 ALIMENTAÇÃO DOS FANS



Conecte o cabo do fan ao primeiro conector do fan no jogo de cabos do tipo breakout com 4 pinos. Use os conectores de fan restantes conforme necessário.

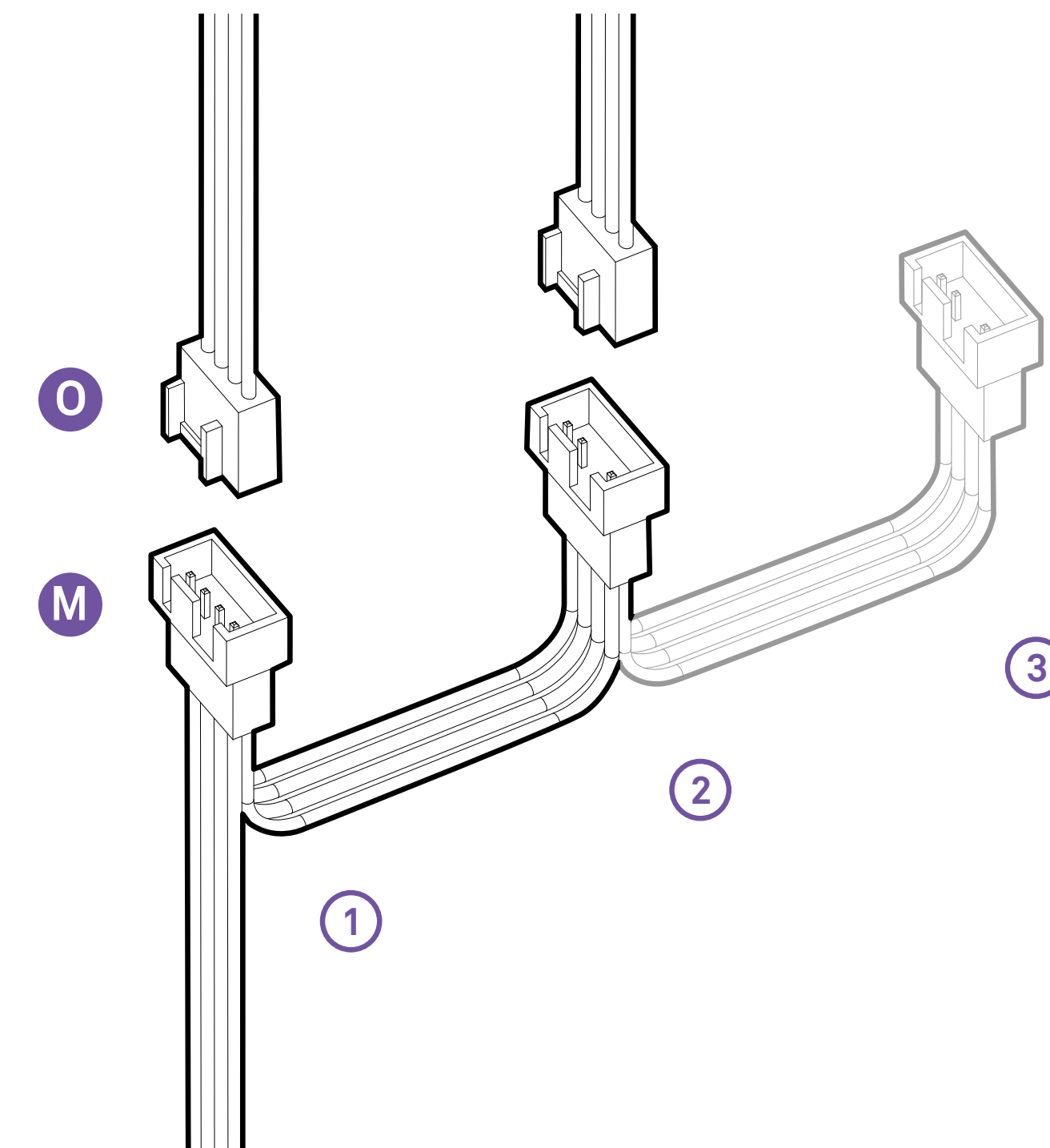

3.6 CONEXÃO DO TACÔMETRO DA BOMBA



Conecte o conector de 3 pinos no jogo de cabos do tipo breakout ao conector CPU_FAN ou AIO_PUMP de 4 pinos na placa-mãe.

OBSERVAÇÃO

- Talvez você precise desativar o aviso de falha do fan no BIOS da placa-mãe se o CPU_FAN não for usado.

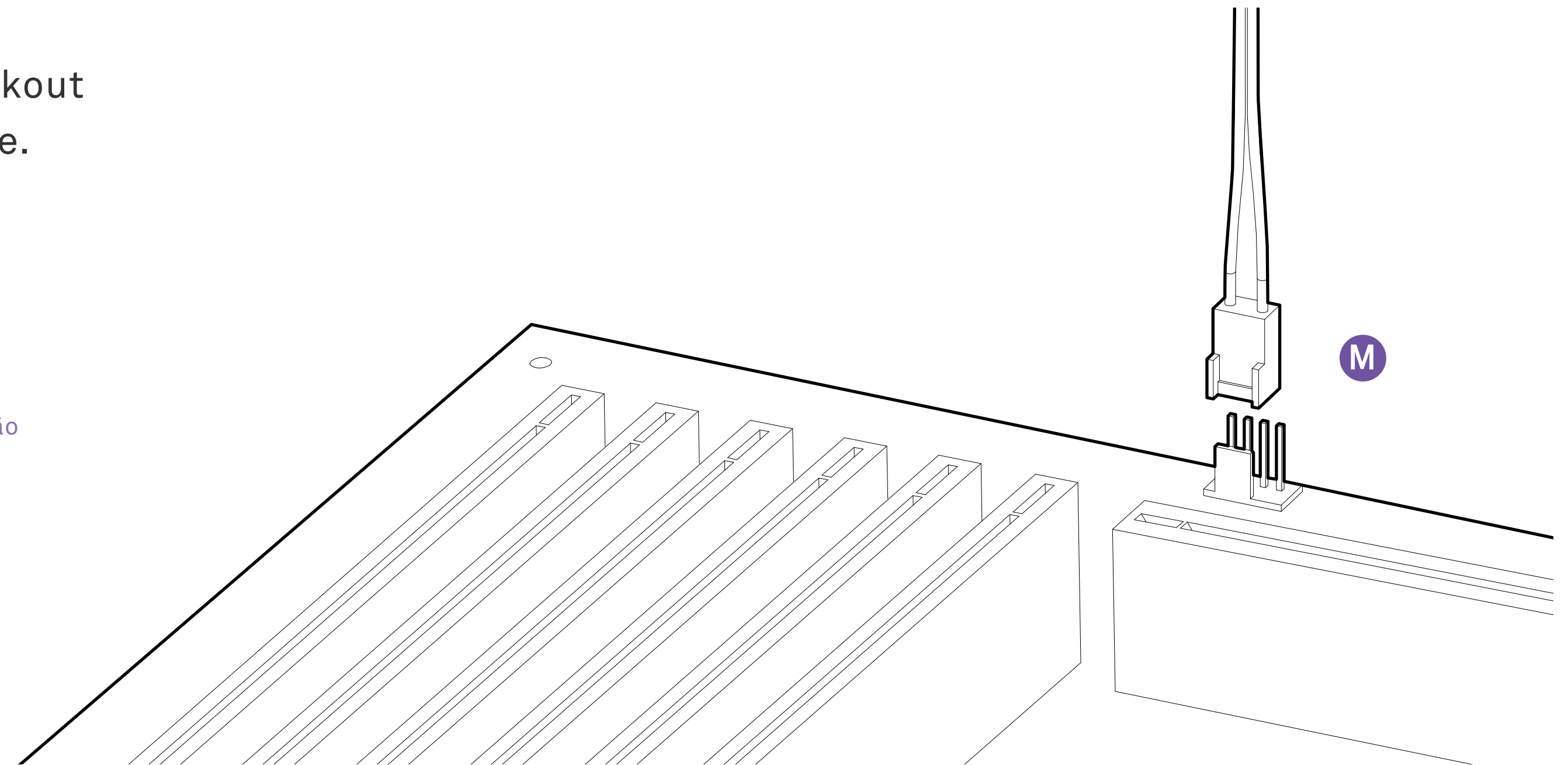

3.7 CONEXÃO DO CABO DE ENERGIA SATA



Conecte o cabo de energia SATA no jogo de cabos de energia ao cabo de energia SATA da fonte de alimentação.

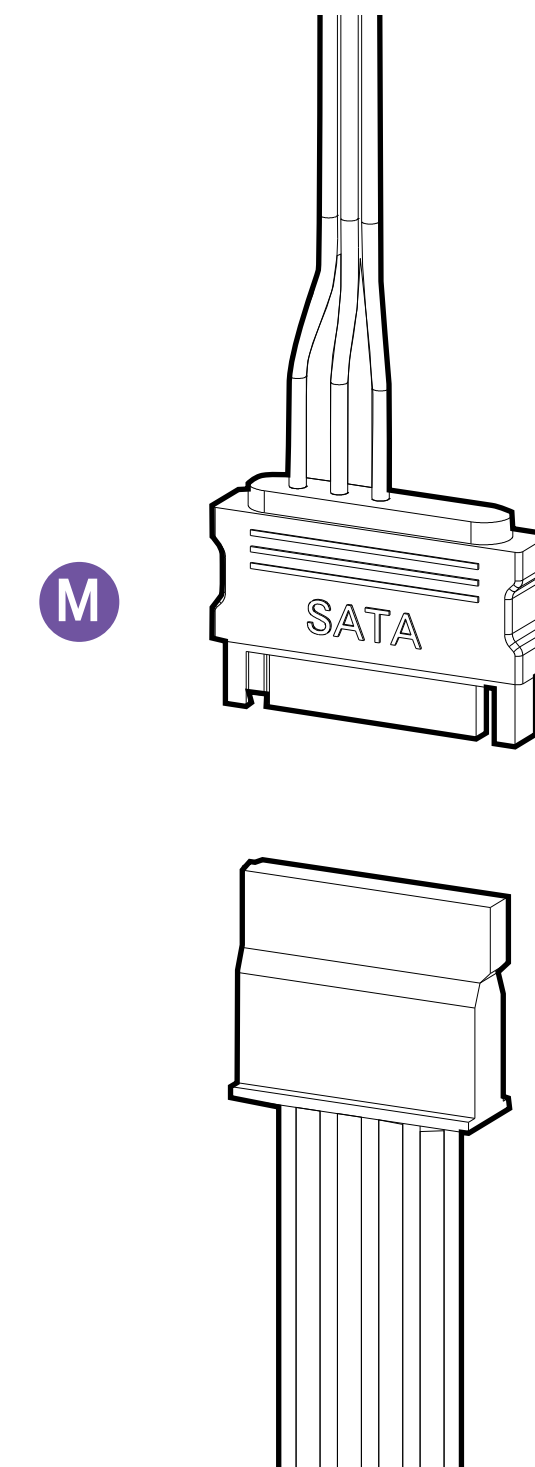

3.8 CONEXÃO DO CABO USB



Conecte o cabo miniUSB da bomba a um conector interno USB 2.0 disponível na placa-mãe.

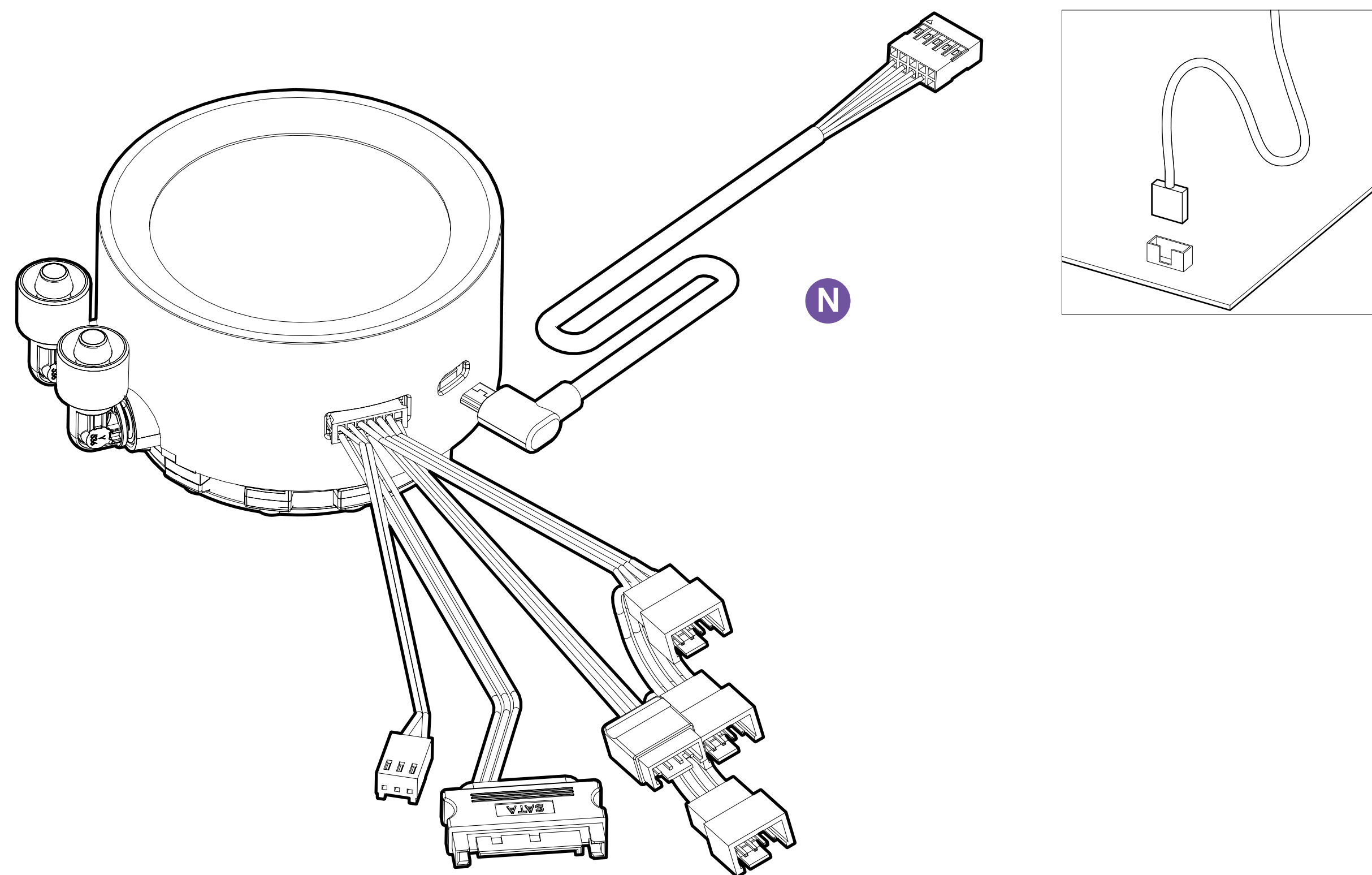

3.9 CONEXÃO DO LED RGB PARA CONTROLE DE ILUMINAÇÃO (OPCIONAL)



Verifique a orientação e conecte dispositivos compatíveis com NZXT RGB ao conector de LED RGB no cabo do tipo breakout. (Acessórios de iluminação vendidos separadamente)

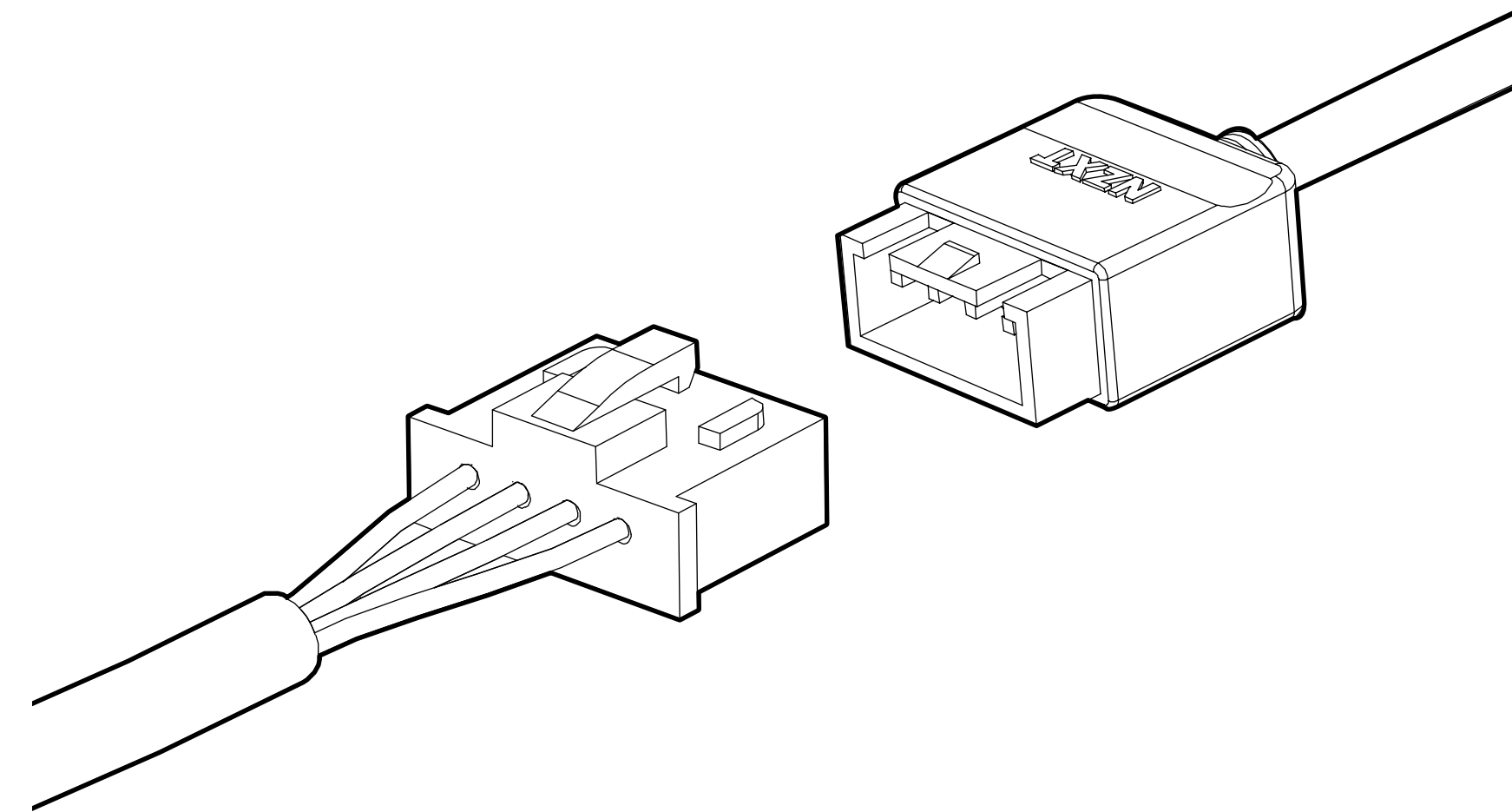

4. DOWNLOAD DO NZXT CAM



NZXT CAM

Download and install NZXT CAM from nzxt.com/camapp.

Descargue e instale NZXT CAM en nzxt.com/camapp.

Téléchargez et installez NZXT CAM depuis nzxt.com/camapp.

laden Sie NZXT CAM von nzxt.com/camapp herunter und installieren Sie die Software.

Scaricare e installare NZXT CAM da nzxt.com/camapp.

Baixe e instale o NZXT CAM de nzxt.com/camapp.

загрузите и установите приложение NZXT CAM со страницы nzxt.com/camapp.

nzxt.com/camapp 에서 NZXT CAM을 다운로드하여 설치하십시오.

NZXT CAMは nzxt.com/camapp からダウンロード・インストール可能です。

請从：nzxt.com/camapp 下载并安装 NZXT CAM 软件。

請從 nzxt.com/camapp 下載並安裝 NZXT CAM。



5.1 NZXT Global Warranty Policy.....A-2

5.3 Regulatory Notices.....A-11

5.2 Support and Service.....A-8

5.1 NZXT GLOBAL WARRANTY POLICY

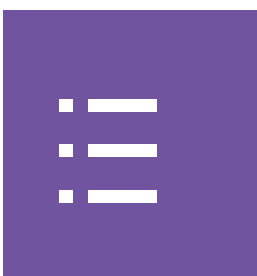

This NZXT Global Warranty Policy governs the sale of products by NZXT to you.

I. WARRANTY LENGTH

Any replacement product will be covered under warranty for the remainder of the warranty period or thirty days, whichever is longer. Proof of purchase is required for warranty service.

II. WHO IS PROTECTED

The Warranty covers only NZXT products purchased by the original consumer.

NEW NZXT PRODUCT	WARRANTY LENGTH FOR PARTS
Computer Cases	2 Years
Temperature Meters	2 Years
Fans	2 Years
Lighting	2 Years
Accessories	2 Years
Kraken M Coolers	3 Years
Headset/Headphone	2 Years
Headset/Headphone Storage	2 Years
Mixer	2 Years
Motherboards	3 Years
Bronze Power Supply	5 Years
Gold Power Supply	10 Years
Kraken X/X RGB/Z Coolers	6 Years
Mini ITX Case with PSU, AIO, and Riser Card	3-year warranty on case, riser card, and AIO. 10-year warranty on PSU.
REFURBISHED NZXT PRODUCT	WARRANTY LENGTH FOR PARTS
All NZXT Certified Refurbished Products	1 Years



III. WHAT IS AND IS NOT COVERED

Please note that our warranty is not an unconditional guarantee. If the product, in NZXT's reasonable opinion, malfunctions within the warranty period, NZXT will provide you at its sole discretion with a repaired or replacement product, either new or refurbished, with a similar function that is equal or greater in value depending on supply.

Our warranty does not cover the following:

- any product or serial number/warranty sticker modification applied without permission from NZXT;
- any damage that is not a manufacturing defect;
- damage, deterioration or malfunction resulting from: accident, abuse, misuse, neglect, fire, water, lightning, or other acts of nature, unauthorized product modification or failure to follow instructions included with the product;
- improper installation, unauthorized alterations or modifications, or repair or attempted repair by anyone not authorized by NZXT;
- shipping or transport damage (claims must be made with the carrier);
- normal wear and tear.

NZXT does not warrant that this product will meet your requirements. It is your responsibility to determine the suitability of this product for your purpose. For NZXT Store orders, we cover two way return shipping for all exchanges and returns. For all other authorized dealers, NZXT Support does not cover return shipping and only covers one way shipping from NZXT back to the end user for exchanges. Two way expedited shipping is provided for all PSUs covered under the Less Than Three program, indiscriminate of purchase location, provided the location is an approved NZXT reseller.

IV. EXCLUSION OF DAMAGES (DISCLAIMER)

NZXT's sole obligation and liability under this warranty is limited to the repair or replacement of a defective product with either a new or refurbished product with a similar function that is equal or greater in value at our option. NZXT shall not, in any event, be liable for any incidental or consequential damage, including but not limited to damages resulting from interruption of service and loss of data, business, or for liability in tort relating to this product or resulting from its use or possession.



V. LIMITATIONS OF IMPLIED WARRANTIES

Here are no other warranties, expressed or implied, including but not limited to those of merchantability or fitness for a particular purpose. The duration of implied warranties is limited to the warranty length specified in Paragraph I.

VI. TO OBTAIN TECHNICAL SUPPORT

If you have already referenced your product owner's manual and still need help, you may contact us by phone at +1 (800) 228-9395, by email at service@nzxt.com, or visit the NZXT Support site at nzxt.com/customer-support.

VII. HOW TO OBTAIN A WARRANTY SERVICE FROM NZXT

To receive a warranty service for your product when purchased directly from NZXT, you must submit a request via the NZXT Support site outlining the problem. If a technician deems the product defective or requiring testing, you will be required to provide a copy of your proof of purchase, which will enable you to submit a Return Merchandise Authorization "RMA" request.

Once approved, you'll receive an RMA number, upon which you will be asked to ship the defective item back to NZXT with the RMA number clearly marked or labelled on the package. NZXT recommends that appropriate measures are taken to safeguard the product from damage during shipping.



VIII. APPLICABLE LAW AND ADDITIONAL LEGAL RIGHTS FOR CONSUMERS

This warranty gives you specific legal rights. These conditions are governed and construed in accordance with the laws of California (with exception of its conflict of law provisions), and the application of the United Nations Convention of Contracts for the International Sale of Goods is expressly excluded. The non-exclusive jurisdiction of the courts of California is agreed, which means that you may bring a claim to enforce your consumer protection rights in connection with this Global Warranty in the country which you have your habitual residence where you may have additional rights. These rights may vary.

For original consumers who are covered by consumer protection laws or regulations in their country, state, or province of purchase or, if different, their country, state, or province of residence, the benefits conferred by this warranty are in addition to all rights and remedies conveyed by such consumer protection laws and regulations. To the extent that liability under such consumer laws can be limited, NZXT's liability is limited, and its sole option, to repair or replacement, either new or refurbished, with a similar function that is equal or greater in value depending on supply.

In the United Kingdom:

- For NZXT products sold to customers in the UK, during the expected lifespan of your product your legal rights entitle you to the following:
 - > Up to 30 days: if your goods are faulty, then you can get an immediate refund.
 - > Up to six months: if your goods can't be repaired or replaced, then you're entitled to a full refund, in most cases.
 - > Up to six years: if your goods do not last a reasonable length of time you may be entitled to some money back.
- If the person seeking to rely on the guarantee is not the original consumer, the NZXT Warranty will cover the product in relation to that person provided that they are able to provide proof of the transfer of the benefit of the guarantee from the original consumer.
- The implied warranties under the Consumer Rights Act 2015 says that your goods must be as described, fit for all purposes for which such goods are usually supplied, and of satisfactory quality.

In the EU:

- If you are a consumer and have your habitual residence in the EU, you additionally enjoy the protection afforded to you by provisions that cannot be derogated from by agreement by virtue of the law where you have your habitual residence.



IX. WARRANTY SERVICE FROM RESELLERS

In the event that a warranty service is sought, you must provide proof of purchase (store receipt or invoice) in order to receive the service and if deemed necessary, repair or replacement product.

In North America:

Within the first 60 days after purchase, please return your product (or for power supplies installed within our enclosures, just the failed power supply) to your dealer or reseller for a replacement. If the product is still within warranty and you can no longer return it to your dealer, please contact NZXT Customer Support (see above) for assistance and instructions. NZXT will not accept returns without prior approval and an RMA number.

In Europe:

Within the first year after purchase, please return your product (or for power supplies installed within our enclosures, just the failed power supply) to your dealer or reseller for a replacement. If the product is still within warranty and you can no longer return it to your dealer, please contact NZXT Customer Support (see above) for assistance and instructions. NZXT will not accept returns without prior approval.

In Australasia:

Within the first two years after purchase, please return your product (or for power supplies installed within our enclosures, just the failed power supply) to your dealer or reseller for a replacement. If the product is still within warranty and you can no longer return it to your dealer, please contact NZXT Customer Support (see above) for assistance and instructions. NZXT will not accept returns without prior approval.

The cost of shipping will be borne at the first instance by you; however, if the purchased item is defective, NZXT will reimburse reasonable postage or transportation of costs.

Outside North America, Europe, and Australasia:

If your product needs to be returned within the warranty period, please contact the retailer or distributor from whom you purchased the product.



X. NZXT.COM STORE RETURNS/EXCHANGE POLICY

Eligible products under this NZXT Warranty qualify for a full refund or exchange only with an authorized RMA number and if the item is returned to the NZXT.com store inventory within 30 days of purchase. Returns are not allowed beyond 30 days of the purchase date. The NZXT.com Store reserves the right to deny any return or exchange. Refunds will be credited to the original method of payment. To initiate a return, simply submit a request via NZXT support site.

- > Visit nzxt.com/warranty and support.nzxt.com for information on warranty coverage and service.
- > Visite el sitio Web nzxt.com/warranty y support.nzxt.com para obtener información sobre la cobertura y el servicio de la garantía.
- > Visitez nzxt.com/warranty et support.nzxt.com pour les informations de la couverture de la garantie et du service.
- > Informationen zu Geltungsbereich und Service der Garantie finden Sie unter support.nzxt.com und nzxt.com/warranty.
- > Visitare il sito nzxt.com/warranty e support.nzxt.com per informazioni sulla copertura e sul servizio della garanzia.
- > Visite nzxt.com/warranty e support.nzxt.com para obter informações sobre a cobertura da garantia e assistência.
- > Подробную информацию об условиях гарантийного обслуживания см. на веб-сайте nzxt.com/warranty и support.nzxt.com.
- > 제품 보증 범위와 서비스 정보를 확인하시려면 nzxt.com/warranty 또는 support.nzxt.com 을 방문해 주시기 바랍니다.
- > 保証範囲およびサービスに関する情報については、support.nzxt.com と nzxt.com/warranty にアクセスしてください。
- > 请造访 nzxt.com/warranty 和 support.nzxt.com 了解保修范围和服务的信息。
- > 請訪問 nzxt.com/warranty 和 support.nzxt.com 了解產品保固範圍和更多服務訊息。

NZXT, Inc./ 15736 E. Valley Blvd, City of Industry, CA 91744, USA
NZXT Europe GmbH/ Industriering Ost 66 | 47906 Kempen | Germany
+1 (800) 228-9395 / service@nzxt.com / [NZXT.com](https://nzxt.com)



SUPPORT AND SERVICE

If you have any questions or problems with the NZXT product you purchased, please don't hesitate to contact us using our support system. support.nzxt.com

Please include a detailed explanation of your problem and your proof of purchase. For comments and suggestions, you can e-mail our design team, designer@nzxt.com. Lastly we would like to thank you for your support by purchasing this product.

For more information about NZXT, please visit us online. NZXT Website: NZXT.com

SOPORTE Y SERVICIO

Si tiene preguntas o problemas con el producto NZXT que usted compró, no dude en ponerse en contacto con service@nzxt.com y suministrar una explicación detallada de su problema así como su prueba de compra.

Puede hacer consultas sobre piezas de repuesto en support.nzxt.com.

Para comentarios y sugerencias, escriba un mensaje de correo electrónico a nuestro equipo de diseño: designer@nzxt.com. Gracias por comprar un producto NZXT. Para más información acerca de NZXT, visítenos en línea. Página web de NZXT: NZXT.com

SUPPORT ET SERVICE

Si vous avez des questions ou des problèmes avec le produit NZXT que vous avez acheté, n'hésitez pas à contacter service@nzxt.com avec une description détaillée de votre problème et votre preuve d'achat. Vous pouvez aussi commander des pièces de remplacement auprès support.nzxt.com. Pour les commentaires et les suggestions, envoyez un email à notre équipe de design, designer@nzxt.com.

Merci d'avoir acheté ce produit de NZXT. Pour plus d'informations sur NZXT, visitez notre site Web. Site Web de NZXT : NZXT.com

KUNDENDIENST UND SERVICE

Falls Fragen oder Probleme bezüglich Ihres NZXT-Produktes auftreten, wenden Sie sich bitte mit einer detaillierten Problembeschreibung und Ihrem Kaufbeleg an service@nzxt.com.

Ersatzteile können Sie unter support.nzxt.com anfragen.

Kommentare und Anregungen senden Sie bitte per designer@nzxt.com an unser Designteam. Vielen Dank, dass Sie ein NZXT-Produkt erworben haben. Weitere Informationen über NZXT erhalten Sie im Internet. NZXT-Webseite: NZXT.com



ASSISTENZA E SERVIZIO

In caso di dubbi o problemi con il prodotto NZXT acquistato, non esitate a contattarci utilizzando il nostro sistema di assistenza. support.nzxt.com Includere una spiegazione dettagliata del problema e la prova di acquisto. Per commenti e suggerimenti, siete pregati di inviare un messaggio al nostro team di progettisti, all'indirizzo: designer@nzxt.com. Infine, vogliamo ringraziarvi del vostro supporto con l'acquisto di questo prodotto. Per altre informazioni su NZXT, visitate il nostro sito. Sito NZXT: NZXT.com

ASSISTÊNCIA E MANUTENÇÃO

Caso tenha questões ou problemas com o produto NZXT adquirido, não hesite em contactar-nos através do endereço service@nzxt.com fornecendo a explicação detalhada do seu problema e a prova de compra. Poderá solicitar peças de substituição através do endereço support.nzxt.com. Para comentários e sugestões, contacte a nossa equipa de design através do endereço de e-mail, designer@nzxt.com. Obrigado por ter adquirido um produto NZXT. Para mais informações acerca da NZXT, visite-nos online. Web site da NZXT: NZXT.com

СЛУЖБА ПОДДЕРЖКИ И ОБСЛУЖИВАНИЯ

В случае возникновения вопросов или неисправностей в приобретенных вами продуктах NZXT обращайтесь по адресу: service@nzxt.com с подробным описанием проблемы и подтверждением покупки. О наличии запчастей можно узнать, обратившись по адресу: support.nzxt.com. Замечания и предложения отправляйте в адрес нашей группы разработчиков: designer@nzxt.com. Благодарим вас за покупку продукта NZXT. Более подробная информация о компании NZXT представлена на наших веб-сайтах. Веб-сайт NZXT: NZXT.com



지원 및 서비스

구입한 NZXT 제품과 관련하여 질문 또는 문제가 있을 경우, 당사의 지원 시스템 (support.nzxt.com)을 사용하여 문의하십시오. 문제를 자세히 기술하고 구매 증빙을 제출하십시오. 의견 또는 제안 사항이 있을 경우 당사 설계 팀에 designer@nzxt.com으로 이메일을 보내십시오. 마지막으로 이 제품을 구입하여 당사를 응원해 주셔서 감사합니다. NZXT에 대해 자세히 알려면 온라인으로 방문하십시오. NZXT 웹사이트: NZXT.com

サポートおよびサービス

購入されましたNZXTの製品に関するご質問または問題は、問題の詳細および購入の証明を添えて、ご遠慮なくservice@nzxt.comまでご連絡ください。交換部品はsupport.nzxt.comまでお尋ねください。ご意見およびご提案は弊社設計チーム、designer@nzxt.comまでメールを送信してください。NZXT製品をご購入いただきましてありがとうございます。NZXTに関する詳細は、インターネット上のウェブサイトをご覧ください。NZXT ウェブサイト: NZXT.com

支持和服务

如果有任何疑问或者在使用 NZXT 产品的过程中遇到任何问题,欢迎联络 service@nzxt.com,联络时请提供关于问题的详细说明及购买凭证。您可以向 support.nzxt.com 查询更换部件。如有任何意见或建议,欢迎致信我们的设计团队,电子邮件地址是 designer@nzxt.com。感谢您购买 NZXT 产品。有关 NZXT 的更多信息,请造访我们的在线网站。NZXT 网站: NZXT.com

支援和服務

如果在使用NZXT 產品的過程中有遇到任何問題或疑問，歡迎聯繫 service@nzxt.com，並請提供問題的詳細敘述及購買證明。您可以透過 support.nzxt.com 查詢更換部件。如有任何意見或建議，歡迎來信與設計團隊聯繫 designer@nzxt.com。最後，感謝您購買 NZXT 產品。有關 NZXT 的更多信息，請訪問我們的網站。NZXT 網站: NZXT.com

5.3 REGULATORY NOTICES



Designed in Los Angeles, California. Made in China 中國製造 中国制造



This device complies with Part 15 of the FCC Rules. Operation is subject to the following two conditions: (1) This device may not cause harmful interference, and (2) this device must accept any interference received, including interference that may cause undesired operation.
CAN ICES-3 (B) / NMB-3 (B)

The maximum ambient temperature is 50°C, the maximum normal operating temperature of the radiator (coolant) is 60°C, and the maximum abnormal temperature of the radiator (coolant) is 70°C.

This equipment is not suitable for use in locations where children are likely to be present.



전기용품안전관리법에 의한 표시

제품명: Liquid CPU Cooling System,
모델명: RL-KRZ73-01/RL-KRZ63-01/RL-KRZ53-01,
정격입력: 5Vdc  ; 12Vdc  , 제조국: 중국,
제조년월: 별도표기, A/S연락처: 080 212 3278



R-R-ZXT-RLKRZ7301

本标识内数字表示产品在正常使用状态下的环保使用年限为10年。
某些部件也可能有环保使用期限标识，其环保使用年限以标识内的数字为准。
说明：电路板/适配器：单板/电路模块上电子元器件的陶瓷或玻璃中含铅。

