

NZXT

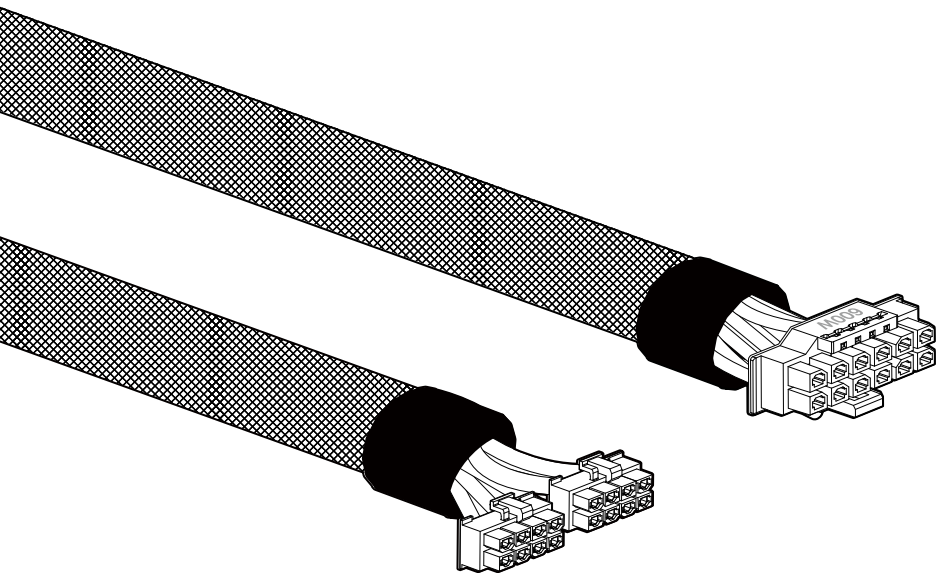

12VHPWR ADAPTER CABLE

16-PIN TO DUAL 8-PIN 12VHPWR PCIE 5.0 PSU CABLE

TABLE OF CONTENTS

VERSION 1.0, 2023/02/23

INSTALLATION 02

NZXT GLOBAL WARRANTY POLICY 04

REGULATORY STATEMENT 07

SUPPORT AND SERVICE 08

INSTALLATION

INSTALACIÓN
INSTALLATION
INSTALLIEREN
INSTALLAZIONE
INSTALAÇÃO

설치
取り付け
安裝
安裝

STEP 1

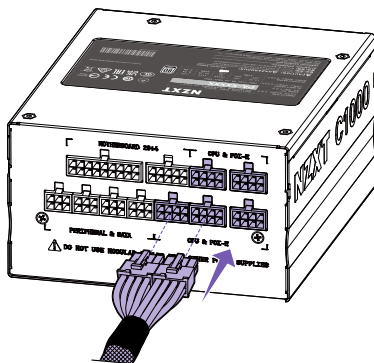

STEP 2

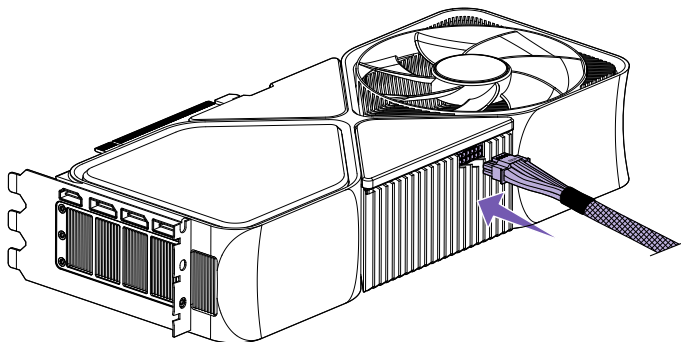

INSTALLATION

INSTALACIÓN
INSTALLATION
INSTALLIEREN
INSTALLAZIONE
INSTALAÇÃO

설치
取り付け
安裝
安裝

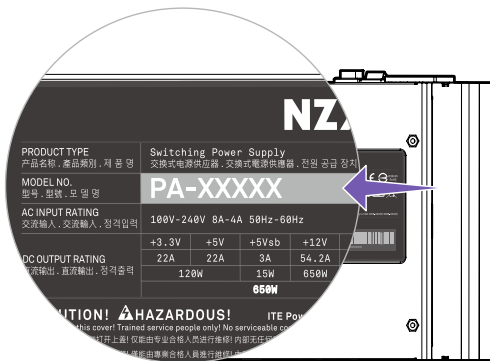

NOTE: The 12VHPWR adapter cable is only compatible with NZXT C Series PSU with model number PA-xxxxx. Do not connect with NZXT's PSU with model number NP-xxxxx. *Reference to the image to find the model number.

WARNING: El cable adaptador 12VHPWR solo es compatible con la fuente de alimentación NZXT de la serie C con el número de modelo PA-xxxxx. No lo conecte con la fuente de alimentación de NZXT's con el número de modelo NP-xxxxx. *Consulte la imagen para encontrar el número de modelo.

WARNING: Le câble adaptateur 12VHPWR est uniquement compatible avec le bloc d'alimentation NZXT de la série C ayant pour référence le n° PA-xxxxx. Ne connectez pas le bloc d'alimentation NZXT's avec le modèle ayant pour référence le n° NP-xxxxx. *Se référer à l'image pour trouver la référence du modèle.

WARNING: Das 12VHPWR-Adapterkabel ist nur mit NZXT-Netzteilen der C-Serie mit der Modellnummer PA-xxxxx kompatibel. Nicht mit NZXT's Netzteilen mit Modellnummer NP-xxxxx verbinden. *Die Modellnummer kann wie auf der Abbildung gezeigt gefunden werden.

WARNING: Il cavo adattatore 12VHPWR è compatibile esclusivamente con l'alimentatore NZXT serie C, numero del modello PA-xxxxx. Non connettere con l'alimentatore NZXT's, numero del modello NP-xxxxx. *Consulta l'immagine per individuare il numero del modello.

WARNING: O cabo adaptador 12VHPWR é compatível apenas com NZXT C Series PSU com número de modelo PA-xxxxx. Não conecte com NZXT's PSU com número de modelo NP-xxxxx. *Faça referência à imagem para encontrar o número do modelo.

WARNING: 12VHPWR 어댑터 케이블은 모델 번호가 PA-xxxxx인 NZXT C 시리즈 PSU와만 호환됩니다. 모델 번호가 NP-xxxxx인 NZXT의 PSU와 연결하지 마십시오. *모델 번호를 찾으려면 이미지를 참조하세요.

WARNING: 12VHPWRアダプターケーブルは、NZXT CシリーズPSUの型番PA-xxxxxとのみ互換性があります。NZXT's PSUの型番NP-xxxxxと接続してはなりません。*型番は画像を参照してください。

WARNING: 12VHPWR 适配器线缆仅兼容型号为 PA-xxxxx 的 NZXT C 系列电源供应器。请勿连接型号为 NP-xxxxx 的 NZXT 电源供应器。* 请参阅图片以查找型号。

WARNING: 12VHPWR 适配器线缆仅与型号编号为 PA-xxxxx 的 NZXT C 系列电源装置相容。请勿连接型号编号为 NP-xxxxx 的 NZXT 电源装置。* 请参阅图片以查找型号编号。

NZXT GLOBAL WARRANTY POLICY

This NZXT Global Warranty Policy governs the sale of products by NZXT to you.

I. WARRANTY LENGTH

New NZXT Product	Warranty Length
Accessories	2 Years

Any replacement product will be covered under warranty for the remainder of the warranty period or thirty days, whichever is longer. Proof of purchase is required for warranty service.

II. WHO IS PROTECTED

The Warranty covers only NZXT products purchased by the original consumer.

III. WHAT IS AND IS NOT COVERED

Please note that our warranty is not an unconditional guarantee. If the product, in NZXT's reasonable opinion, malfunctions within the warranty period, NZXT will provide you at its sole discretion with a repaired or replacement product, either new or refurbished, with a similar function that is equal or greater in value depending on supply. Our warranty does not cover the following:

- any product or serial number/warranty sticker modification applied without permission from NZXT;
- any damage that is not a manufacturing defect;
- damage, deterioration or malfunction resulting from: accident, abuse, misuse, neglect, fire, water, lightning, or other acts of nature, unauthorized product modification or failure to follow instructions included with the product;
- improper installation, unauthorized alterations or modifications, or repair or attempted repair by anyone not authorized by NZXT;
- shipping or transport damage (claims must be made with the carrier);
- normal wear and tear.

NZXT does not warrant that this product will meet your requirements. It is your responsibility to determine the suitability of this product for your purpose. For NZXT Store orders, we cover two way return shipping for all exchanges and returns. For all other authorized dealers, NZXT Support does not cover return shipping and only covers one way shipping from NZXT back to the end user for exchanges. Two way expedited shipping is provided for all PSUs covered under the Less Than Three program, indiscriminate of purchase location, provided the location is an approved NZXT reseller.

IV. EXCLUSION OF DAMAGES (DISCLAIMER)

NZXT's sole obligation and liability under this warranty is limited to the repair or replacement of a defective product with either a new or refurbished product with a similar function that is equal or greater in value at our option. NZXT shall not, in any event, be liable for any incidental or consequential damage, including but not limited to damages resulting from interruption of service and loss of data, business, or for liability in tort relating to this product or resulting from its use or possession.

V. LIMITATIONS OF IMPLIED WARRANTIES

There are no other warranties, expressed or implied, including but not limited to those of merchantability or fitness for a particular purpose. The duration of implied warranties is limited to the warranty length specified in Paragraph I.

VI. TO OBTAIN TECHNICAL SUPPORT

If you have already referenced your product owner's manual and still need help, you may contact us by phone at +1 (800) 228-9395, by email at service@nzxt.com, or visit the NZXT Support site at nzxt.com/customer-support.

VII. HOW TO OBTAIN A WARRANTY SERVICE FROM NZXT

To receive a warranty service for your product when purchased directly from NZXT, you must submit a request via the NZXT Support site outlining the problem. If a technician deems the product defective or requiring testing, you will be required to provide a copy of your proof of purchase, which will enable you to submit a Return Merchandise Authorization "RMA" request.

Once approved, you'll receive an RMA number, upon which you will be asked to ship the defective item back to NZXT with the RMA number clearly marked or labelled on the package. NZXT recommends that appropriate measures are taken to safeguard the product from damage during shipping.

VIII. APPLICABLE LAW AND ADDITIONAL LEGAL RIGHTS FOR CONSUMERS

This warranty gives you specific legal rights. These conditions are governed and construed in accordance with the laws of California (with exception of its conflict of law provisions), and the application of the United Nations Convention of Contracts for the International Sale of Goods is expressly excluded. The non-exclusive jurisdiction of the courts of California is agreed, which means that you may bring a claim to enforce your consumer protection rights in connection with this Global Warranty in the country which you have your habitual residence where you may have additional rights. These rights may vary.

For original consumers who are covered by consumer protection laws or regulations in their country, state, or province of purchase or, if different, their country, state, or province of residence, the benefits conferred by this warranty are in addition to all rights and remedies conveyed by such consumer protection laws and regulations. To the extent that liability under such consumer laws can be limited, NZXT's liability is limited, and its sole option, to repair or replacement, either new or refurbished, with a similar function that is equal or greater in value depending on supply.

In the United Kingdom:

- For NZXT products sold to customers in the UK, during the expected lifespan of your product your legal rights entitle you to the following:
 - > Up to 30 days: if your goods are faulty, then you can get an immediate refund.
 - > Up to six months: if your goods can't be repaired or replaced, then you're entitled to a full refund, in most cases.
 - > Up to six years: if your goods do not last a reasonable length of time you may be entitled to some money back.
- If the person seeking to rely on the guarantee is not the original consumer, the NZXT Warranty will cover the product in relation to that person provided that they are able to provide proof of the transfer of the benefit of the guarantee from the original consumer.
- The implied warranties under the Consumer Rights Act 2015 says that your goods must be as described, fit for all purposes for which such goods are usually supplied, and of satisfactory quality.

In the EU:

- If you are a consumer and have your habitual residence in the EU, you additionally enjoy the protection afforded to you by provisions that cannot be derogated from by agreement by virtue of the law where you have your habitual residence.

IX. WARRANTY SERVICE FROM RESELLERS

In the event that a warranty service is sought, you must provide proof of purchase (store receipt or invoice) in order to receive the service and if deemed necessary, repair or replacement product.

In North America:

Within the first 60 days after purchase, please return your product (or for power supplies installed within our enclosures, just the failed power supply) to your dealer or reseller for a replacement. If the product is still within warranty and you can no longer return it to your dealer, please contact NZXT Customer Support (see above) for assistance and instructions. NZXT will not accept returns without prior approval and an RMA number.

In Europe:

Within the first year after purchase, please return your product (or for power supplies installed within our enclosures, just the failed power supply) to your dealer or reseller for a replacement. If the product is still within warranty and you can no longer return it to your dealer, please contact NZXT Customer Support (see above) for assistance and instructions. NZXT will not accept returns without prior approval.

In Australasia:

Within the first two years after purchase, please return your product (or for power supplies installed within our enclosures, just the failed power supply) to your dealer or reseller for a replacement. If the product is still within warranty and you can no longer return it to your dealer, please contact NZXT Customer Support (see above) for assistance and instructions. NZXT will not accept returns without prior approval.

The cost of shipping will be borne at the first instance by you; however, if the purchased item is defective, NZXT will reimburse reasonable postage or transportation of costs.

Outside North America, Europe, and Australasia:

If your product needs to be returned within the warranty period, please contact the retailer or distributor from whom you purchased the product.

X. NZXT.COM STORE RETURNS/EXCHANGE POLICY

Eligible products under this NZXT Warranty qualify for a full refund or exchange only with an authorized RMA number and if the item is returned to the NZXT.com store inventory within 30 days of purchase. Returns are not allowed beyond 30 days of the purchase date. The NZXT.com Store reserves the right to deny any return or exchange. Refunds will be credited to the original method of payment. To initiate a return, simply submit a request via NZXT support site.

- > Visit nzxt.com/warranty and support.nzxt.com for information on warranty coverage and service.
- > Visite el sitio Web nzxt.com/warranty y support.nzxt.com para obtener información sobre la cobertura y el servicio de la garantía.
- > Visitez nzxt.com/warranty et support.nzxt.com pour les informations de la couverture de la garantie et du service.
- > Informationen zu Geltungsbereich und Service der Garantie finden Sie unter support.nzxt.com und nzxt.com/warranty.
- > Visitate il sito nzxt.com/warranty e support.nzxt.com per informazioni sulla copertura e sul servizio della garanzia.
- > Visite nzxt.com/warranty e support.nzxt.com para obter informações sobre a cobertura da garantia e assistência.
- > 제품 보증 범위와 서비스 정보를 확인하시려면 nzxt.com/warranty 또는 support.nzxt.com 을 방문해 주시기 바랍니다.
- > 保証範圍およびサービスに関する情報については、support.nzxt.com と nzxt.com/warranty にアクセスしてください。
- > 請造訪 nzxt.com/warranty 和 support.nzxt.com 了解保修范围和服務的信息。
- > 請訪問 nzxt.com/warranty 和 support.nzxt.com 了解產品保固範圍和更多服務訊息。

NZXT, Inc. | 15736 E. Valley Blvd, City of Industry, CA 91744, USA

NZXT Europe GmbH | Ammerthalstrasse 32 Kirchheim bei Muenchen 85551, Germany

NZXT UK Ltd. | First Floor 5 Fleet Place London EC4M 7RD, GB United Kingdom

+1 (800) 228-9395 / service@nzxt.com / nzxt.com

REGULATORY STATEMENT

WEEE

Disposal of Waste Electrical and Electronic Equipment and/or Battery by users in private households in the European Union.



This symbol on the product or on the packaging indicates that this can not be disposed of as household waste. You must dispose of your waste equipment and/or battery by handing it over to the applicable take-back scheme for the recycling of electrical and electronic equipment and/or battery. For more information about recycling of this equipment and/or battery, please contact your city office, the shop where you purchased the equipment or your household waste disposal service. The recycling of materials will help to conserve natural resources and ensure that it is recycled in a manner that protects human health and environment.

Recycling information: See <http://www.benq.com/support/recycle> for details.

SUPPORT AND SERVICE

SUPPORT AND SERVICE

If you have any questions or problems with the NZXT product you purchased, please don't hesitate to contact us using our support system.

service@nzxt.com support.nzxt.com

Please include a detailed explanation of your problem and your proof of purchase. For comments and suggestions, you can e-mail our design team, designer@nzxt.com.

Lastly we would like to thank you for your support by purchasing this product. For more information about NZXT, please visit us online. NZXT Website: [NZXT.com](https://nzxt.com)

SOPORTE Y SERVICIO

Si tiene preguntas o problemas con el producto NZXT que usted compró, no dude en ponerse en contacto con service@nzxt.com y suministrar una explicación detallada de su problema así como su prueba de compra.

Puede hacer consultas sobre piezas de repuesto en support.nzxt.com.

Para comentarios y sugerencias, escriba un mensaje de correo electrónico a nuestro equipo de diseño: designer@nzxt.com.

Gracias por comprar un producto NZXT. Para más información acerca de NZXT, visítenos en línea. Página web de NZXT: [NZXT.com](https://nzxt.com)

SUPPORT ET SERVICE

Si vous avez des questions ou des problèmes avec le produit NZXT que vous avez acheté, n'hésitez pas à contacter service@nzxt.com avec une description détaillée de votre problème et votre preuve d'achat.

Vous pouvez aussi commander des pièces de remplacement auprès support.nzxt.com.

Pour les commentaires et les suggestions, envoyez un email à notre équipe de design, designer@nzxt.com.

Merci d'avoir acheté ce produit de NZXT. Pour plus d'informations sur NZXT, visitez notre site Web. Site Web de NZXT : [NZXT.com](https://nzxt.com)

KUNDENDIENST UND SERVICE

Falls Fragen oder Probleme bezüglich Ihres NZXT-Produktes auftreten, wenden Sie sich bitte mit einer detaillierten Problembeschreibung und Ihrem Kaufbeleg an service@nzxt.com.

Ersatzteile können Sie unter support.nzxt.com anfragen.

Kommentare und Anregungen senden Sie bitte per designer@nzxt.com an unser Designteam.

Vielen Dank, dass Sie ein NZXT-Produkt erworben haben. Weitere Informationen über NZXT erhalten Sie im Internet. NZXT-Webseite: [NZXT.com](https://nzxt.com)

ASSISTENZA E SERVIZIO

In caso di dubbi o problemi con il prodotto NZXT acquistato, non esitate a contattarci utilizzando il nostro sistema di assistenza. support.nzxt.com
Includere una spiegazione dettagliata del problema e la prova di acquisto. service@nzxt.com

Per commenti e suggerimenti, siete pregati di inviare un messaggio al nostro team di progettisti, all'indirizzo: designer@nzxt.com.

Infine, vogliamo ringraziarvi del vostro supporto con l'acquisto di questo prodotto. Per altre informazioni su NZXT, visitate il nostro sito.

Sito NZXT: [NZXT.com](https://nzxt.com)

ASSISTÊNCIA E MANUTENÇÃO

Como tenha questões ou problemas com o produto NZXT adquirido, não hesite em contactar-nos através do endereço service@nzxt.com fornecendo a explicação detalhada do seu problema e a prova de compra.

Poderá solicitar peças de substituição através do endereço support.nzxt.com.

Para comentários e sugestões, contacte a nossa equipa de design através do endereço de e-mail, designer@nzxt.com.

Obrigado por ter adquirido um produto NZXT. Para mais informações acerca da NZXT, visitenos online. Web site da NZXT: NZXT.com

지원 및 서비스

구입한 NZXT 제품과 관련하여 질문 또는 문제가 있을 경우, 당사의 지원 시스템 support.nzxt.com 을 사용하여 문의하십시오. 문제를 자세히 기술하고 구매 증빙을 제출하십시오. service@nzxt.com

의견 또는 제안 사항이 있을 경우 당사 설계 팀에 designer@nzxt.com으로 이메일을 보내십시오.

마지막으로 제품을 구입하여 당사를 응원해 주셔서 감사합니다. NZXT에 대해 자세히 알려면 온라인으로 방문하십시오. NZXT 웹사이트: NZXT.com

サポートおよびサービス

購入されましたNZXTの製品に関するご質問または問題は、問題の詳細および購入の証明を添えて、ご遠慮なく service@nzxt.com までご連絡ください。

交換部品は support.nzxt.com までお尋ねください。

ご意見およびご提案は弊社設計チーム、designer@nzxt.com までメールを送信してください。

NZXT製品をご購入いただきましてありがとうございます。NZXTに関する詳細は、インターネット上のウェブサイトをご覧ください。NZXT ウェブサイト: NZXT.com

支持和服務

如果有任何疑问或者在使用 NZXT 产品的过程中遇到任何问题，欢迎联络 service@nzxt.com，联络时请提供关于问题的详细说明及购买凭证。

您可以向 support.nzxt.com 查询更换部件。

如有任何意见或建议，欢迎致信我们的设计团队，电子邮件地址是 designer@nzxt.com。

感谢您购买 NZXT 产品，有关 NZXT 的更多信息，请造访我们的在线网站。NZXT 网站: NZXT.com

支援和服務

如果在使用 NZXT 產品的過程中有遇到任何問題或疑問，歡迎聯繫 service@nzxt.com，並請提供問題的詳細敘述及購買證明。

您可以透過 support.nzxt.com 查詢更換部件。

如有任何意見或建議，歡迎來信與設計團隊聯繫 designer@nzxt.com。

最後，感謝您購買 NZXT 產品。有關 NZXT 的更多資訊，請瀏覽我們的網站。NZXT 網站: NZXT.com

NZXT

NZXT, Inc. | 15736 E. Valley Blvd, City of Industry, CA 91744, USA

NZXT Europe GmbH | Ammerthalstrasse 32 Kirchheim bei Muenchen 85551, Germany

NZXT UK Ltd. | First Floor 5 Fleet Place London EC4M 7RD, GB United Kingdom

+1 (800) 228-9395 / service@nzxt.com / nzxt.com

立光科技國際股份有限公司 | 台北市中山區長安東路二段 36巷 3號 1樓