

P11104DC
(For flat materials)
700 lbs [320 kg]

P11004DC
(For curved materials)
600 lbs [270 kg]

P1HV1104DC
(For rough materials)
600 lbs [270 kg]

CHANNEL LIFTERS - P1

In addition to a modular design, these Powr-Grip® vacuum lifters provide 180° rotation and 90° tilt, for expandability and a full range of load motion at the installation site or on the shop floor.

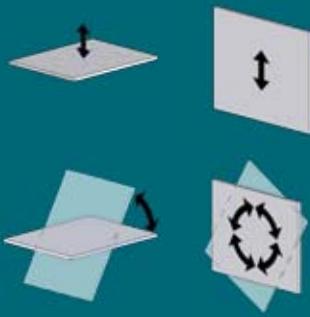
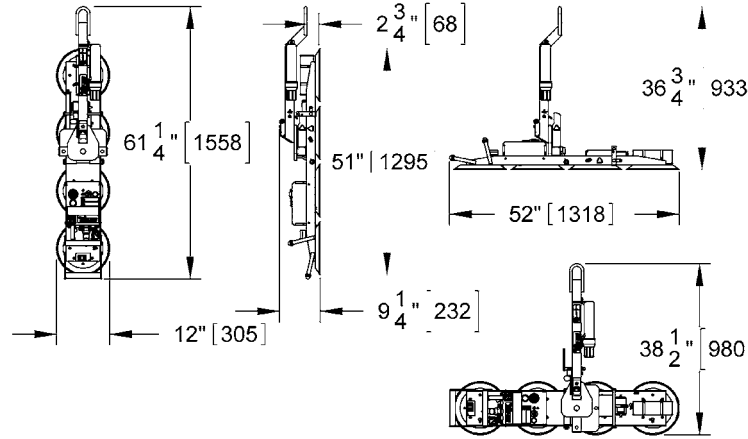

**THE ORIGINAL
& TRUSTED NAME
IN VACUUM LIFTING
EQUIPMENT**

Standard Pad Spread:	P11104DC: 51" x 12" [1295 x 305 mm] P11004DC: 49" x 10" [1245 x 254 mm] P1HV1104DC: 50" x 11" [1270 x 280 mm]
Number / Size of Pads:	P11104DC: 4 / 11" [28 cm] dia. lipped P11004DC: 4 / 10" [25 cm] dia. concave P1HV1104DC: 4 / 10" [25 cm] dia. lipped
Load Capacity: (On smooth, nonporous surfaces. Please contact us for recommendations on other surfaces.)	P11104DC: 700 lbs [320 kg] P11004DC: 600 lbs [270 kg] (Capacity is reduced on curved surfaces. Please contact us for capacity on curved surfaces.) P1HV1104DC: 600 lbs [270 kg]
Average Unit Weight:	70 lbs [32 kg]
Standard Operating Power:	12 volts DC, 10 amps (for each Pad Channel)
Load Movement:	Manual rotation, 180° edgewise, with locking in three positions. Manual tilt, 90° between upright and flat, with automatic latching in upright position. (Units can be tilted ONLY when the lift bar is locked in the center position, as shown on drawings.)
Standard Features:	On-board battery and charger Battery energy gauge Low vacuum warning light Vacuum gauge Vacuum line filter Vacuum reserve tank
Alternative Power Systems:	Air (venturi) power system (P11104AIRS, P11004AIRS or P1HV1104AIRS) AC power system (P11104AC, P11004AC or P1HV1104AC) (Specifications may not be as listed above. Please contact us for more information.)
Available Options:	Remote control system (EO8RC1) Movable control pendant (EO9RP) Dual vacuum system (EO10DVS) Individual pad shutoffs (CM1COWB) Closed cell foam pad rings (FRHV11) (Available on P1HV1104 units only) ABS shipping case (53005) (see page 2 for more information)

Wood's Powr-Grip Co., Inc.
908 West Main - P.O. Box 368
Laurel, Montana 59044 U.S.A.
406.628.8231 (phone)
406.628.8354 (fax)

800.548.7341
www.powrgrip.com



Products are manufactured under an ISO 9001 quality management system

Wood's Powr-Grip products are sold through authorized dealers.

Design Standards:
(See www.powrgrip.com for more
information.)

ASME B30.20 - 2006
(BTH-1 Design Category "B", Service Class "0")
CE
AS 4991 - 2004

COMPONENTS

PAD CHANNELS

Each channel features an independent, on-board vacuum generating system, including vacuum pump, vacuum controls and standard features as listed on page 1.

PC1104: (for flat materials) 4 / 11" [28 cm] dia. lipped pads

PC1004: (for curved materials) 4 / 10" [25 cm] dia. concave pads

PCHV1104: (for rough materials) 4 / 10" [25 cm] dia. lipped pads

LIFT FRAMES

PCFT1A1: For one Pad Channel

PCFT2SA45: For two Pad Channels, approx. 4½' [1.38 m] pad spread

PCFT2SA7: For two Pad Channels, approx. 7' [2.14 m] pad spread

INTERCHANGEABLE ARMS

(Pad spread can be changed if optional arms are purchased)

FA245: Optional arms convert PCFT2SA7 Lift Frame to PCFT2SA45 Lift Frame

FA27: Optional arms convert PCFT2SA45 Lift Frame to PCFT2SA7 Lift Frame



SHIPPING CASE FOR P1 VACUUM LIFTERS

(vacuum lifter and case sold separately)

Designed specifically for shipping and storing Powr-Grip® P11104, P11004 and P1HV1104 Vacuum Lifters.

Durable thermo-formed ABS construction.

Three straps on inside of case hold vacuum lifter firmly in place.

Eight plastic buckles attached to nylon straps hold case in closed position.

Handles molded into the case structure enable convenient handling.

Ribbed exterior of case enables easy stacking of multiple lifters.

Case design incorporates grooves on the bottom to facilitate forklift handling.