

CHANNEL LIFTER

As a smaller version of Powr-Grip's popular P1 Channel Lifter, this mighty little vacuum lifter is ideal for handling and installing commercial or residential windows. An on-board, DC power system enhances lifter portability, while a Dual Vacuum System improves load security.

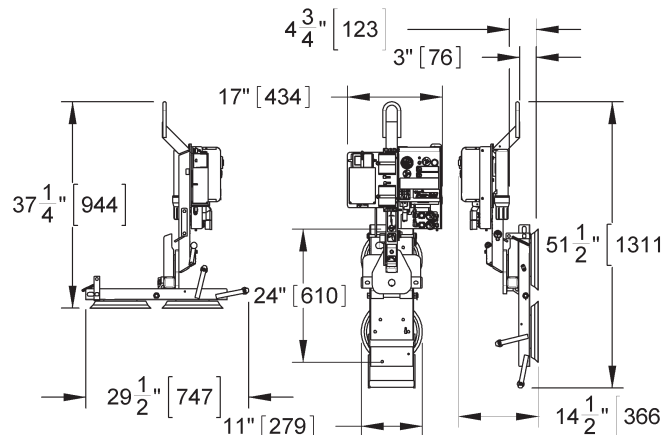

Standard Pad Spread	24" x 11" [610 x 279 mm]
Number / Size of Pads	2 / 10" [25 cm] dia. lipped vacuum pads
Load Capacity (On smooth, nonporous surfaces. Please contact us for recommendations on other surfaces.)	300 lbs [135 kg]
Unit Weight	72 lbs [33 kg]
Standard Operating Power	12 volts DC, 10 amps
Load Movement	Manual rotation, 180° edgewise, with locking in three positions. Manual tilt, 90° between upright and flat, with automatic latching in upright position (Lifters can be tilted ONLY when lift bar is locked in center position, as shown above.)
Standard Features	Dual vacuum system Low vacuum warning light and buzzer On-board battery and charger Battery energy gauge Vacuum gauges Vacuum line filters Vacuum reserve tanks
Available Options	Movable control pendant (EO9RP) Closed cell foam vacuum pad rings (FRHV11) Alternative vacuum pads: 9" [23 cm] diameter vacuum pad (VPFS9) 10" [25 cm] dia. concave vacuum pad (G0750) 11" [28 cm] dia. lipped vacuum pad (G3370) (Specifications not as listed above. Please contact us for more information.)
Design Standards (See www.powrgrip.com for more information.)	ASME B30.20 - 2006 (BTH-1 Design Category "B", Service Class "0") CE AS 4991 - 2004

P1HV1102DC
300 lbs [135 kg]

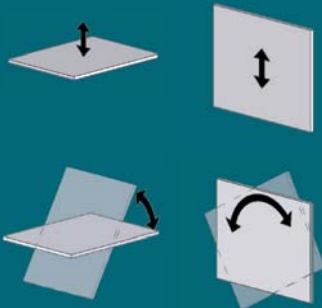

**THE ORIGINAL
& TRUSTED NAME
IN VACUUM LIFTING
EQUIPMENT**

Wood's Powr-Grip Co., Inc.
908 West Main - P.O. Box 368
Laurel, Montana 59044 U.S.A.
406.628.8231 (phone)
406.628.8354 (fax)

800.548.7341
www.powrgrip.com



Products are manufactured under an ISO 9001 quality management system

Wood's Powr-Grip products are sold through authorized dealers.