

## INDUSTRIAL TRUCKS

PRODUCT CATEGORY CLASSIFICATION: UN CPC 4353 (EXCLUDING TRACTORS OF THE TYPE USED ON RAILWAY STATION PLATFORMS)

*PCR REGISTRATION NUMBER TO BE ADDED BY THE SECRETARIAT*

**DRAFT VERSION 1.0.0 FOR OPEN CONSULTATION. DO NOT CITE OR USE.**

VALID UNTIL 20XX-YY-ZZ (TO BE ADDED BY THE SECRETARIAT)

DRAFT PCR FOR OPEN  
CONSULTATION

## INDUSTRIAL TRUCKS

PRODUCT CATEGORY CLASSIFICATION: UN CPC 4353 (EXCLUDING TRACTORS OF THE TYPE USED ON RAILWAY STATION PLATFORMS)

## INTRODUCTION TO OPEN CONSULTATION

This draft PCR document is available for open consultation from 2025-02-12 until 2025-04-11. Feel free to forward the draft to any other stakeholder you might think is relevant, including colleagues and other organisations.

We are interested in comments from stakeholders on:

- General
  - Alignment with PCRs available in other programmes for type III environmental declarations, industry-specific LCA guidelines or similar.
- Scope of PCR
  - Product category definition and description
  - Classification of product category using CPC codes
- Goal and scope, life cycle inventory and life cycle impact assessment
  - Functional unit/declared unit
  - System boundary
  - Allocation rules
  - Data quality requirements
  - Recommended databases for generic data
  - Impact categories and impact assessment methodology
- Additional information

Comments shall be sent directly to the PCR Moderator (contact details available in Section 1). There is a template for comments on [www.environdec.com](http://www.environdec.com) that may be used.

For questions about the PCR, please contact the PCR moderator. For general questions about the International EPD System, EPD or PCR development, please contact the Secretariat via [support@environdec.com](mailto:support@environdec.com).

INDUSTRIAL TRUCKS

PRODUCT CATEGORY CLASSIFICATION: UN CPC 4353 (EXCLUDING TRACTORS OF THE TYPE USED ON RAILWAY STATION PLATFORMS)

## TABLE OF CONTENTS

|                                                           |    |
|-----------------------------------------------------------|----|
| Introduction to open consultation.....                    | 2  |
| 1 Introduction.....                                       | 4  |
| 2 General information.....                                | 5  |
| 2.1 Administrative information.....                       | 5  |
| 2.2 Scope of PCR.....                                     | 6  |
| 3 Review and background information.....                  | 8  |
| 3.1 Open consultation.....                                | 8  |
| 3.2 PCR review.....                                       | 8  |
| 3.3 Existing PCRs for the product category.....           | 8  |
| 3.4 Reasoning for development of PCR.....                 | 9  |
| 3.5 Underlying studies used for PCR development.....      | 9  |
| 4 LCA method.....                                         | 10 |
| 4.1 Modelling approach.....                               | 10 |
| 4.2 functional unit.....                                  | 10 |
| 4.3 Process flow diagram.....                             | 15 |
| 4.4 Cut-off rules.....                                    | 16 |
| 4.5 Allocation rules.....                                 | 16 |
| 4.6 Data and data quality rules.....                      | 16 |
| 4.7 Other LCA rules.....                                  | 16 |
| 4.8 Specific rules per life-cycle stage and module D..... | 17 |
| 4.9 Environmental performance indicators.....             | 18 |
| 4.10 Specific rules per EPD type.....                     | 18 |
| 5 Content of LCA report.....                              | 20 |
| 6 Content and format of EPD.....                          | 21 |
| 6.1 EPD languages.....                                    | 21 |
| 6.2 Units and quantities.....                             | 21 |
| 6.3 Use of images in EPD.....                             | 21 |
| 6.4 Sections of the EPD.....                              | 21 |
| 7 List of abbreviations.....                              | 24 |
| 8 References.....                                         | 25 |
| 9 Version history of PCR.....                             | 26 |
| 10 ANNEX 1.....                                           | 27 |

INDUSTRIAL TRUCKS

PRODUCT CATEGORY CLASSIFICATION: UN CPC 4353 (EXCLUDING TRACTORS OF THE TYPE USED ON RAILWAY STATION PLATFORMS)

# 1 INTRODUCTION

This document constitutes Product Category Rules (PCR) developed in the framework of the International EPD System: a programme for Environmental Product Declarations (EPD)<sup>1</sup> according to ISO 14025:2006, ISO 14040:2006, ISO 14044:2006, and product-specific standards, such as EN 15804 and ISO 21930 for construction products. EPDs are voluntary documents for a company or an industry association to present transparent, consistent, and verifiable information about the environmental performance of their products (goods or services).

The General Programme Instructions (GPI), publicly available on [www.environdec.com](http://www.environdec.com), includes the rules for the overall administration and operation of the programme and the basic rules for developing EPDs registered in the programme. A PCR complements the GPI and the normative standards by providing specific rules, and guidelines for developing an EPD for one or more specific product categories (see Figure 1), thereby enabling the generation of consistent EPDs within a product category. A PCR should not repeat the rules and guidelines of the GPI, but include additions, specifications and deviations to the rules set in the GPI. As such, a PCR shall be used together with the GPI.

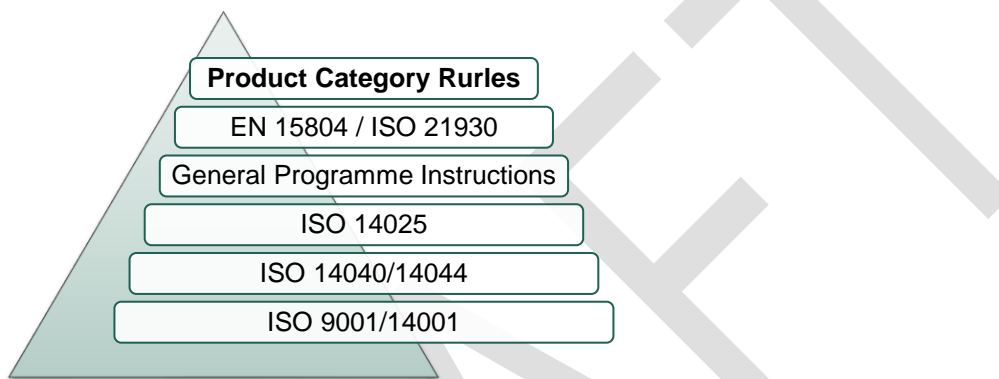

Figure 1. The hierarchy between PCRs, standards, and other documents. EN 15804 and ISO 21930 are normative standards for construction products only.

The present PCR uses the following terminology:

- The term “shall” is used to indicate what is obligatory, i.e., a requirement.
- The term “should” is used to indicate a recommendation. Any deviation from a recommendation shall be justified in the EPD development process.
- The terms “may” or “can” are used to indicate an option that is permissible.

For definitions of other terms used in the document, see the GPI and normative standards.

Any references to this PCR shall include the PCR registration number, name, and version number.

The programme operator maintains the copyright of the PCR to ensure that it is possible to publish, update, and make it available to all organisations to develop and register EPDs. Stakeholders participating in PCR development should be acknowledged in the final document and on the website.

<sup>1</sup> Termed type III environmental declarations in ISO 14025.

INDUSTRIAL TRUCKS

PRODUCT CATEGORY CLASSIFICATION: UN CPC 4353 (EXCLUDING TRACTORS OF THE TYPE USED ON RAILWAY STATION PLATFORMS)

## 2 GENERAL INFORMATION

### 2.1 ADMINISTRATIVE INFORMATION

|                                  |                                                                                                                                                                                                                                                                                                                                                                                                                                                                                                                                                                                                                                                                                                                                                                                                                                                                                                                                                                                                                                                                                                                                                                                                                                                                                                                                                                                                                                                                                                                                                                                                                                                              |
|----------------------------------|--------------------------------------------------------------------------------------------------------------------------------------------------------------------------------------------------------------------------------------------------------------------------------------------------------------------------------------------------------------------------------------------------------------------------------------------------------------------------------------------------------------------------------------------------------------------------------------------------------------------------------------------------------------------------------------------------------------------------------------------------------------------------------------------------------------------------------------------------------------------------------------------------------------------------------------------------------------------------------------------------------------------------------------------------------------------------------------------------------------------------------------------------------------------------------------------------------------------------------------------------------------------------------------------------------------------------------------------------------------------------------------------------------------------------------------------------------------------------------------------------------------------------------------------------------------------------------------------------------------------------------------------------------------|
| Name:                            | Industrial trucks                                                                                                                                                                                                                                                                                                                                                                                                                                                                                                                                                                                                                                                                                                                                                                                                                                                                                                                                                                                                                                                                                                                                                                                                                                                                                                                                                                                                                                                                                                                                                                                                                                            |
| Registration number and version: | <i>To be added by the Secretariat</i>                                                                                                                                                                                                                                                                                                                                                                                                                                                                                                                                                                                                                                                                                                                                                                                                                                                                                                                                                                                                                                                                                                                                                                                                                                                                                                                                                                                                                                                                                                                                                                                                                        |
| Programme:                       | <br>The International EPD System                                                                                                                                                                                                                                                                                                                                                                                                                                                                                                                                                                                                                                                                                                                                                                                                                                                                                                                                                                                                                                                                                                                                                                                                                                                                                                                                                                                                                                                                                                                                            |
| Programme operator:              | EPD International AB, Box 210 60, SE-100 31 Stockholm, Sweden.<br>Website: <a href="http://www.environdec.com">www.environdec.com</a><br>E-mail: <a href="mailto:support@environdec.com">support@environdec.com</a>                                                                                                                                                                                                                                                                                                                                                                                                                                                                                                                                                                                                                                                                                                                                                                                                                                                                                                                                                                                                                                                                                                                                                                                                                                                                                                                                                                                                                                          |
| PCR Moderator:                   | Elena Neri, INDACO2 srl, <a href="mailto:elena.neri@indaco2.it">elena.neri@indaco2.it</a>                                                                                                                                                                                                                                                                                                                                                                                                                                                                                                                                                                                                                                                                                                                                                                                                                                                                                                                                                                                                                                                                                                                                                                                                                                                                                                                                                                                                                                                                                                                                                                    |
| PCR Committee:                   | KION Group, INDACO2 Srl, Ecodynamics Group - University of Siena, Still SpA, Dematic, ICIM Group                                                                                                                                                                                                                                                                                                                                                                                                                                                                                                                                                                                                                                                                                                                                                                                                                                                                                                                                                                                                                                                                                                                                                                                                                                                                                                                                                                                                                                                                                                                                                             |
| Publication date:                | <i>To be added by the Secretariat</i><br>See Section 9 for a version history of the PCR.                                                                                                                                                                                                                                                                                                                                                                                                                                                                                                                                                                                                                                                                                                                                                                                                                                                                                                                                                                                                                                                                                                                                                                                                                                                                                                                                                                                                                                                                                                                                                                     |
| Valid until:                     | <i>To be added by the Secretariat</i><br>The validity may change. See <a href="http://www.environdec.com">www.environdec.com</a> for the latest version of the PCR and the latest information on its validity and transition periods between versions.                                                                                                                                                                                                                                                                                                                                                                                                                                                                                                                                                                                                                                                                                                                                                                                                                                                                                                                                                                                                                                                                                                                                                                                                                                                                                                                                                                                                       |
| Development and updates:         | <p>The PCR has been developed following ISO 14027, including public consultation and review. The rules for the development and updating processes are described in Section 9 of the GPI.</p> <p>The PCR is valid for a pre-determined time period to ensure that it is updated at regular intervals. When the PCR is about to expire, the PCR Moderator shall initiate a discussion with the Secretariat on if and how to proceed with updating the PCR and renewing its validity. A PCR may be updated before it expires, based on changes in normative standards or provided significant and well-justified proposals for changes or amendments are presented.</p> <p>When there has been an update of the PCR, the new version should be used to develop EPDs. For small updates (change of third-digit version number), the previous version is normally immediately removed from the PCR library on <a href="http://www.environdec.com">www.environdec.com</a> and there is no transition period. For medium updates (change of second-digit version number), the previous version of the PCR is valid in parallel during a transition period of at least 90 days, but not exceeding its previously set validity period. For large updates (change of first-digit version number), the previous version is valid in parallel during a transition period of at least 180 days, but not exceeding its previously set validity period.</p> <p>Stakeholder feedback on PCRs is very much encouraged. Any comments on this PCR may be sent directly to the PCR Moderator and/or the Secretariat during its development or during its period of validity.</p> |

## INDUSTRIAL TRUCKS

PRODUCT CATEGORY CLASSIFICATION: UN CPC 4353 (EXCLUDING TRACTORS OF THE TYPE USED ON RAILWAY STATION PLATFORMS)

|                                      |                                                                                                                                                                                                                                                                                                     |
|--------------------------------------|-----------------------------------------------------------------------------------------------------------------------------------------------------------------------------------------------------------------------------------------------------------------------------------------------------|
| Standards and documents conformance: | General Programme Instructions of the International EPD System, version 5.0.0, based on ISO 14025 and ISO 14040/14044. <sup>2</sup>                                                                                                                                                                 |
| PCR language(s):                     | At the time of publication, this PCR was available in English. If the PCR is available in several languages, these are available on <a href="http://www.environdec.com">www.environdec.com</a> . In case of translated versions, the English version takes precedence in case of any discrepancies. |

## 2.2 SCOPE OF PCR

### 2.2.1 PRODUCT CATEGORY DEFINITION AND DESCRIPTION

This document provides Product Category Rules (PCR) for the assessment of the environmental performance of Industrial trucks and the declaration of this performance by an EPD. The product category corresponds to UN CPC 4353 - Fork-lifts trucks; other work trucks whether or not fitted with lifting or handling equipment (excluding tractors of the type used on railway station platforms).

The product category covered by the scope of this PCR is industrial trucks identified as wheeled vehicles having at least three wheels with a powered or non-powered driving mechanism — except those running on rails — which are designed either to carry, tow, push, lift, stack or tier in racks any kind of load, and which are controlled either by an operator or by driverless automation, as defined by the Industrial trucks vocabulary: ISO 5053-1:2020- Industrial trucks — Vocabulary — Part 1: Types of industrial trucks.

All the truck types are characterized by common components, such as liftings system, forks, chassis. Some variants are constituted by: powered or non-powered driving mechanism/ electric & electronic component / controlled by an operator or by driverless automation.

Examples of products included in the scope of this PCR are, e.g., forklift trucks, heavy duty trucks, pallet trucks, hand pallet trucks, pallet stackers, very narrow aisle trucks, reach trucks, tow trucks, logistic trains (see exemplificative figures in Annex 1 of this PCR).

The classification in the UN CPC system is Subclass 43530:

- Division 43 - " General-purpose machinery "
- Group 435 " Lifting and handling equipment and parts thereof "
- Class 4353 and Subclass: 43530 "Fork-lift trucks; other works trucks whether or not fitted with lifting or handling equipment; tractors of the type used on railway station platforms (this PCR)

Additional information is available on <https://unstats.un.org/unsd/classifications/Family/Detail/1074>.

This PCR does not include tractors of the type used on railway station platforms belonging to the same CPC Subclass

### 2.2.2 GEOGRAPHICAL SCOPE

This PCR may be used globally.

### 2.2.3 EPD VALIDITY

An EPD becomes valid as of its version date (see Section 8.4.5 of the GPI). When an EPD is originally published, the validity period is normally five years starting from the version date or until the EPD has been de-registered from the International EPD System. Shorter validity periods are also accepted, for example if decided by the EPD owner.

<sup>2</sup> Some rules influencing EPD development are independent of the GPI version referred to in the PCR. For example, the latest rules on EPD verification procedures in the GPI shall be followed within 90 days of its publication. See Section 5.1 in the GPI for a description of the four categories of rules and when they shall be followed.

INDUSTRIAL TRUCKS

PRODUCT CATEGORY CLASSIFICATION: UN CPC 4353 (EXCLUDING TRACTORS OF THE TYPE USED ON RAILWAY STATION PLATFORMS)

For rules on when an EPD shall be updated and re-verified during its validity, see Section 6.7.1 of the GPI. For validity periods in case of updates of EPDs, see Section 6.6 of the GPI.

The version date and the period of validity shall be stated in the EPD.

Publication of a new version of the PCR or the GPI does not affect the validity of already published EPDs.

DRAFT

INDUSTRIAL TRUCKS

PRODUCT CATEGORY CLASSIFICATION: UN CPC 4353 (EXCLUDING TRACTORS OF THE TYPE USED ON RAILWAY STATION PLATFORMS)

### 3 REVIEW AND BACKGROUND INFORMATION

This PCR was developed in accordance with the PCR development process described in the GPI of the International EPD System, including open consultation and review.

#### 3.1 OPEN CONSULTATION

##### 3.1.1 VERSION 1.0.0

This PCR was available for open consultation from 2025-02-12 until 2025-04-11, during which any stakeholder was able to provide comments by contacting the PCR Moderator and/or the Secretariat.

Stakeholders were invited via e-mail or other means to take part in the open consultation and were encouraged to forward the invitation to other relevant stakeholders. The following stakeholders provided comments during the open consultation and agreed to be listed as contributors in the PCR and on [www.environdec.com](http://www.environdec.com):

- *List of stakeholder names and affiliation (to be added after the open consultation).*

*In case no stakeholders provided comments and agreed to be listed as contributors, the above sentence shall be adjusted accordingly (“No stakeholders provided comments during the open consultation and agreed to be listed as contributors in the PCR and on [www.environdec.com](http://www.environdec.com).”) and the bullet list shall be removed.*

#### 3.2 PCR REVIEW

##### 3.2.1 VERSION 1.0.0

|                          |                                                                                                                                                                                                                                                                                                                                                                                                                                                                                 |
|--------------------------|---------------------------------------------------------------------------------------------------------------------------------------------------------------------------------------------------------------------------------------------------------------------------------------------------------------------------------------------------------------------------------------------------------------------------------------------------------------------------------|
| PCR review panel:        | The Technical Committee of the International EPD System. A full list of members is available on <a href="http://www.environdec.com">www.environdec.com</a> . The review panel may be contacted via <a href="mailto:support@environdec.com">support@environdec.com</a> .<br><br>Members of the Technical Committee were requested to state any potential conflict of interest with the PCR Committee, and if there were conflicts of interest they were excused from the review. |
| Chair of the PCR review: | <i>To be added by the Secretariat</i>                                                                                                                                                                                                                                                                                                                                                                                                                                           |
| Review dates:            | <i>To be added by the Secretariat</i>                                                                                                                                                                                                                                                                                                                                                                                                                                           |

#### 3.3 EXISTING PCRS FOR THE PRODUCT CATEGORY

As part of the development of this PCR, existing PCRs and other internationally standardised methods that could potentially act as PCRs were considered to avoid unnecessary overlaps in scope and to ensure harmonisation with established methods of relevance for the product category. The existence of such documents was checked among the following EPD programmes and international standardisation bodies:

- International EPD System. [www.environdec.com](http://www.environdec.com).
- IBU – Institut Bauen und Umwelt e.V., <https://epd-online.com/>
- Epd-norge, <https://www.epd-norge.no>
- EPD Italy, <https://www.epditaly.it/en/documents/>
- PEP ecopassport, <http://www.pep-ecopassport.org/>
- JEMAI EcoLeaf, <http://www.ecoleaf-jemai.jp/eng/pcr.html>



INDUSTRIAL TRUCKS

PRODUCT CATEGORY CLASSIFICATION: UN CPC 4353 (EXCLUDING TRACTORS OF THE TYPE USED ON RAILWAY STATION PLATFORMS)

- Product Environmental Footprint (PEF) initiative, European Commission <https://ec.europa.eu/environment/eussd/smgp/>

Table 1 lists the identified PCRs and other standardised methods.

Table 1. Existing PCRs and other internationally standardised methods that were considered to avoid overlap in scope and to ensure harmonisation with established methods.

| Name of PCR/standard, incl. registration number                            | Programme/standardisation body | Version number/date of publication | Scope                                                                                                                                               |
|----------------------------------------------------------------------------|--------------------------------|------------------------------------|-----------------------------------------------------------------------------------------------------------------------------------------------------|
| PCR 2010:08 Other special- and general-purpose machinery and parts thereof | The International EPD System   | Version 4.0, published 2022-04-04  | UN CPC 449 Other special-purpose machinery and parts thereof, 439 Other general-purpose machinery and parts thereof and class 44221 and class 44629 |

No existing PCRs or other relevant internationally standardized methods with overlapping scope were identified.

### 3.4 REASONING FOR DEVELOPMENT OF PCR

This PCR was developed to enable publication of EPDs for the product category defined in Section 2.2.1 based on ISO 14025 and ISO 14040/14044. The PCR enables different practitioners to generate consistent results when assessing the environmental impact of products of the same product category, and thereby it supports comparability of products within a product category.

### 3.5 UNDERLYING STUDIES USED FOR PCR DEVELOPMENT

The methodological choices made during the development of this PCR (declared/functional unit, system boundary, allocation methods, impact categories, data quality rules, etc.) were primarily based on the following underlying studies:

- CFP Report - KION Linde N20, Rev.1 November 2024

INDUSTRIAL TRUCKS

PRODUCT CATEGORY CLASSIFICATION: UN CPC 4353 (EXCLUDING TRACTORS OF THE TYPE USED ON RAILWAY STATION PLATFORMS)

## 4 LCA METHOD

This section provides rules for the LCA method used to develop an EPD for the product category as defined in Section 2.2.1. The basic rules of the LCA method are set in Annex A of the GPI, and this section only includes additions, specifications and deviations to the rules set in the GPI. Guidance and examples of applying the LCA method are also available on [www.environdec.com/methodology](http://www.environdec.com/methodology).

### 4.1 MODELLING APPROACH

See Section A.1 of the GPI.

### 4.2 FUNCTIONAL UNIT

EPDs based on this PCR shall use a Functional Unit (FU). The FU is defined as one unit of product used during the lifespan (see below for further details).

The reference flow is defined as one unit of product (plus its packaging, if applicable) leaving the factory gate.

To increase comparability between different types of products, in addition to declaring the results for one unit of product during the lifespan, results for GWP-GHG and WDP shall also be declared for 1 hour operation.

#### 4.2.1 TECHNICAL SPECIFICATION AND LIFESPAN

The technical lifespan of the Industrial Truck (i.e., the average time for which the product has been designed or proven to last) is considered the same of actual lifespan (i.e., the average time for which the product has been shown to be in use). Hereafter, generally "lifespan".

The lifespan should be 10000 h for warehouse and 20000 h for counterbalanced trucks as an average scenario.

A different lifespan is accepted only if based on proof/evidence, if justified and verifiable. It shall be clearly described in the EPD.

The list of the spare parts replaced throughout the lifespan and its replacement frequency shall be included and declared in the EPD (See Sections 4.2.3.3 and 4.8.3 for more details).

The following technical specification of the Industrial Truck shall be presented in the LCA report and EPD:

- Truck type (e.g., forklift, heavy duty, pallet, very narrow aisle, reach, tow truck, logistic train, order picker)
- Power supply type (e.g., internal combustion or electric)
- If internal combustion, detail the fuel type (e.g., gasoline, diesel, GLP)
- If electric, detail the battery type (e.g., Li-Ion or Lead-Acid)
- Maximum load (in ton)
- Movimentation type (i.e., handing or lifting)
- Work environment (i.e., indoor or outdoor)

#### 4.2.2 SYSTEM BOUNDARY

The scope of this PCR and EPDs based on it is *cradle-to-grave* for electric engine powered and IC (Internal Combustion) machineries; *cradle-to-grave with options* for hand pallet trucks (module B is optional).

All environmentally relevant processes from "cradle to grave" should be included, so that at minimum 95% of the total energy use, mass of product content, and environmental impact is accounted for (see Section 4.4).

## INDUSTRIAL TRUCKS

PRODUCT CATEGORY CLASSIFICATION: UN CPC 4353 (EXCLUDING TRACTORS OF THE TYPE USED ON RAILWAY STATION PLATFORMS)

### 4.2.3 LIFE-CYCLE STAGES AND INFORMATION MODULES

Because of different data quality rules and the presentation of results, the product life cycle shall be divided into the following life-cycle stages and information modules:

- Product stage, modules A1-A3:
  - A1: Raw material extraction and processing (e.g., mining, agricultural and forestry operations), production of intermediate materials and components (e.g., including transformation processes such as rolling, drawing and extrusion), processing of secondary material input (e.g., recycling processes), production of distribution and consumer packaging, etc.
  - A2: Transports to the manufacturer of the product
  - A3: Manufacturing of the product<sup>3</sup>
- Distribution and installation stage, modules A4-A5:
  - A4: Transport of the product to the distribution site/user, including storage of product (e.g., warehouse and retail operations).
  - A5: Installation of the product, for example component assembly (e.g., including transports and waste processing of material and product losses arising in A5), if relevant.
- Use stage, modules B1-B7:
  - B1: Use/application/operation of the product (e.g., consumptions and emissions not included in B2-B7)
  - B2: Maintenance of the product
  - B3: Repair of the product
  - B4: Replacement
  - B5: Refurbishment
  - B6: Energy use in use/application/operation (e.g., including direct emissions associated with its use).
  - B7: Water use in use/application/operation
- End-of-life stage, modules C1-C4:
  - C1: De-construction/demolition/deinstallation
  - C2: Transport to waste processing and/or disposal
  - C3: Waste processing for reuse, recovery and/or recycling
  - C4: Disposal

In addition, consequences of recovered material/energy beyond the product cycle shall be reported in module D.

In the EPD, the environmental performance of each of the life-cycle stages and module D shall be reported separately, and in aggregated form for the life-cycle stages (modules A-C).

Section A.3.1 of the GPI outlines rules for how to assign generation of electricity and production of fuels, steam and other energy carriers used, and losses arising, in each information module.

Sections 4.2.3.1 to 4.2.3.5 further describe the processes to include or exclude for each life-cycle stage.

Note that generation of electricity and production of fuels, steam and other energy carriers shall be assigned to the information module in which the energy carrier is used. Also note that each module shall include the waste processing of waste generated in the module up to the end-of-waste state or final disposal; except waste processing of the product itself, which is included in module C. Related, note the way of assigning losses described in Figure 3 of Section A.3.1 of the GPI.

<sup>3</sup> These are often, but not always, the processes under operational control of the EPD owner.

## INDUSTRIAL TRUCKS

PRODUCT CATEGORY CLASSIFICATION: UN CPC 4353 (EXCLUDING TRACTORS OF THE TYPE USED ON RAILWAY STATION PLATFORMS)

## 4.2.3.1 Modules A1-A3: Product stage

- Module A1:
  - extraction and production of raw materials for truck components (e.g. steel, aluminium, plastics, powder coating ) and the production of supplied components (e.g. batteries, forks, lifting systems, wheels, counterweight for counterbalance trucks) that are not internally manufactured
  - recycling processes of secondary materials from other product life cycles,
  - generation of electricity and production of fuels, steam and other energy carriers used in the module,
  - waste treatment of waste generated in the module
- Module A2:
  - transport of materials/components to the manufacturing plant
- Module A3:
  - truck (and components, if internally performed) manufacturing, including e.g. carpentry, painting, assembly, testing, packaging (if applicable)
  - ordinary maintenance of equipment used in the manufacturing ( <3years ),
  - generation of electricity and production of fuels, steam and other energy carriers used in the module,
  - waste treatment of waste generated in the module, including its transport to waste treatment platform

Processes not listed here may also be included. All elementary flows at resource extraction shall be included, except for the flows that fall under the general cut-off rule in Section 4.4.

The following processes shall not be included:

- manufacturing of production equipment, buildings and other capital goods,
- business travel of personnel,
- travel to and from work by personnel, and
- research and development activities.

Any other exclusion shall be justified

## 4.2.3.2 Modules A4-A5: Distribution and installation stage

- Module A4:
  - Transport of the final product from manufacturing to the distribution platform (if applicable)
  - Transport to the final user

If specific data are too diversified, an average scenario referred to the representative distribution macro-area shall be adopted (e.g., Europe, America, Asia). It is allowed to add additional scenarios (max 3) in the Environmental Performance section.

- Module A5:
  - Waste treatment of the product packaging (if applicable) , including its transport to waste treatment platform
  - Installation (if applicable), e.g. electricity consumptions for assembly of some components at the final user

This module shall be aligned/ referred to the same scenario adopted for A4. It is allowed to add additional scenarios (max 3) in the Environmental Performance section.

Processes not listed here may also be included. All elementary flows at resource extraction shall be included, except for the flows that fall under the general cut-off rule in Section 4.4.

Any other exclusion shall be justified

## INDUSTRIAL TRUCKS

PRODUCT CATEGORY CLASSIFICATION: UN CPC 4353 (EXCLUDING TRACTORS OF THE TYPE USED ON RAILWAY STATION PLATFORMS)

## 4.2.3.3 Modules B1-B7: Use stage (mandatory for electric engine powered and Internal Combustion machineries; optional for hand pallet trucks)

- Module B1:
  - Use of the Industrial Truck (e.g. cleaning and other consumptions not included in B2-B7)
- Module B2:
  - Maintenance of the Industrial Truck (e.g. lubricating oil, grease, air filters, Lead-Acid water refill)
- Module B3:
  - Repairing of Industrial Truck components
- Module B4:
  - Replacement of spare parts (e.g. belts, wheels)
- Module B5:
  - Refurbishment of Industrial Truck components (e.g. batteries, drivers cab components, repainting chassis components, hydraulic system as hoses, valves).
- Module B6:
  - Operational energy use (e.g. electricity, fuel) and direct emissions (e.g. for internal combustion trucks)
- Module B7:
  - Operational water use

Each B module includes the production, components, and product inputs to the module e.g. production and transport of consumables used in maintenance (B2), or new product components/spare parts used in replacement (B4). The transport of spare parts is considered not relevant for this type of products, and can be excluded.

Waste treatment (i.e. up to the end-of-waste state or final disposal) shall be included in each module where the waste is generated, including its transport to waste treatment platform (e.g. the waste treatment of exhausted parts that are replaced, shall be included in the module where wasted).

All modules shall be accounted for the lifespan, according to manufacturer technical data sheets.

These modules shall be aligned/ referred to the same scenario adopted for A4. It is allowed to add additional scenarios (max 3) in the Environmental Performance section.

Processes not listed here may also be included. All elementary flows at resource extraction shall be included, except for the flows that fall under the general cut-off rule in Section 4.4.

Any other exclusion shall be justified

## 4.2.3.4 Modules C1-C4: End-of-life stage

- Module C1:
  - De-installation (if applicable), e.g. electricity consumptions for disassembly some components before sending the Industrial Truck to waste treatment
- Module C2:
  - Transport of Industrial Truck to waste treatment
- Module C3:
  - Waste processing for reuse, recovery and/or recycling of the Industrial Truck, up to the end-of-waste state
- Module C4:
  - Disposal of the Industrial Truck

## INDUSTRIAL TRUCKS

PRODUCT CATEGORY CLASSIFICATION: UN CPC 4353 (EXCLUDING TRACTORS OF THE TYPE USED ON RAILWAY STATION PLATFORMS)

These modules shall be aligned/ referred to the same scenario adopted for A4. It is allowed to add additional scenarios (max 3) in the Environmental Performance section.

Processes not listed here may also be included. All elementary flows at resource extraction shall be included, except for the flows that fall under the general cut-off rule in Section 4.4.

Any other exclusion shall be justified

The declaration of environmental consequences of reuse, recycling and/or recovery of materials and energy beyond the product system is permitted in module D (optional). These results shall be separately declared. Note that module D is not part of the product system and thus not considered to be a life-cycle stage.

#### 4.2.3.5 Excluded processes

See Section A.3.1.1 of the GPI.

In addition, packaging of components, adhesive, labels, lubricating grease can be excluded

### 4.2.4 OTHER BOUNDARY SETTING RULES

See Section A.3.2 of the GPI for rules on setting boundaries to nature as well as geographical and temporal boundaries. See Section A.4 of the GPI and Section 4.5 below for rules on setting boundaries to other product systems.

INDUSTRIAL TRUCKS

PRODUCT CATEGORY CLASSIFICATION: UN CPC 4353 (EXCLUDING TRACTORS OF THE TYPE USED ON RAILWAY STATION PLATFORMS)

### 4.3 PROCESS FLOW DIAGRAM

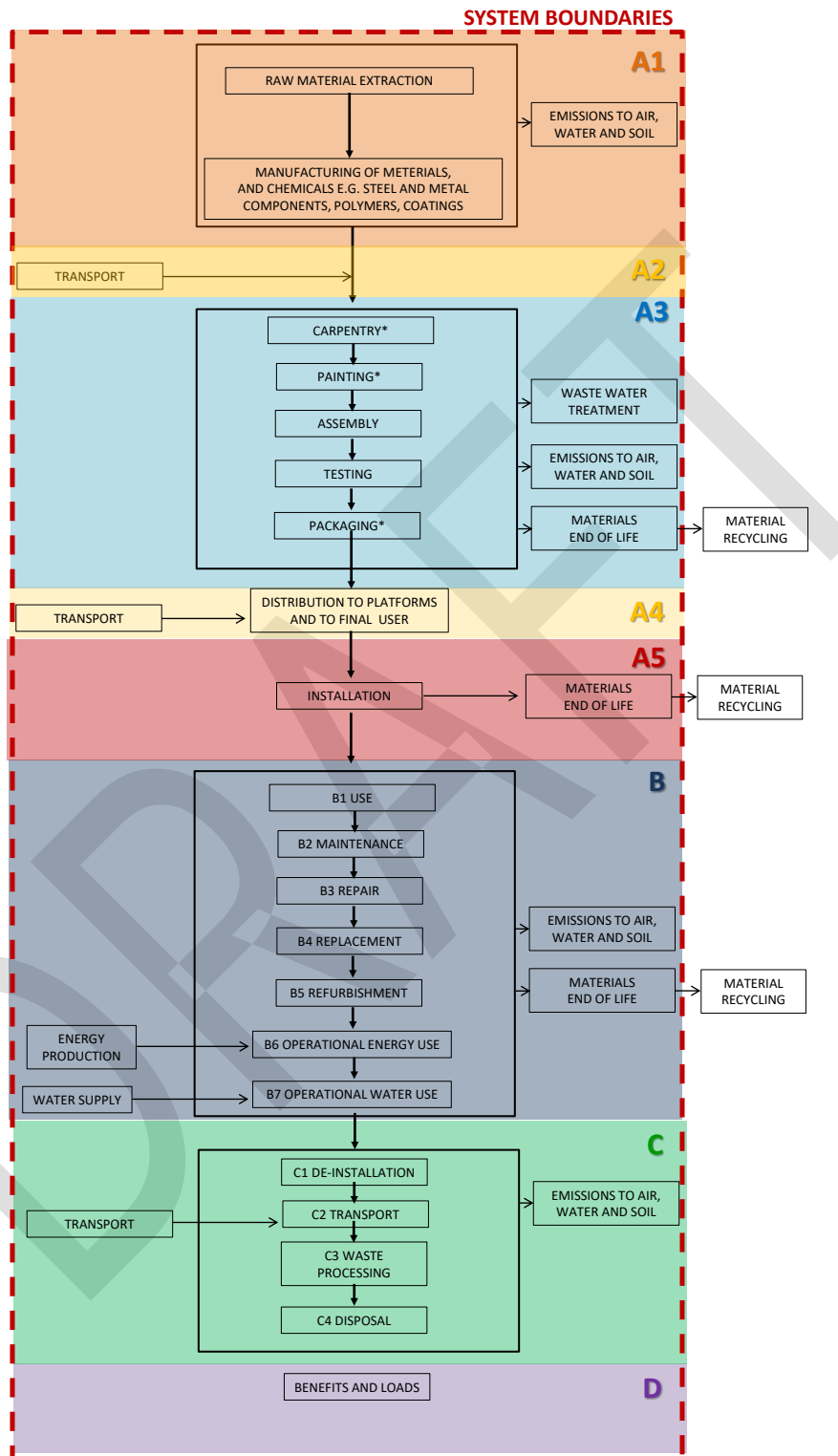

Figure 2. Process flow diagram illustrating the processes that shall be included in the product system, divided into the life-cycle stages. The illustration of processes to include may not be exhaustive. \*=operations that can be internally or externally

## INDUSTRIAL TRUCKS

PRODUCT CATEGORY CLASSIFICATION: UN CPC 4353 (EXCLUDING TRACTORS OF THE TYPE USED ON RAILWAY STATION PLATFORMS)

*performed. Module B is mandatory for electric engine powered and Internal Combustion machineries; optional for hand pallet trucks. Module D is optional*

## 4.4 CUT-OFF RULES

See Section A.3.3 of the GPI.

## 4.5 ALLOCATION RULES

See Section A.4 of the GPI.

### 4.5.1 ALLOCATION OF CO-PRODUCTS

See Section A.4.1 of the GPI.

### 4.5.2 ALLOCATION OF WASTE

See Section A.4.2 of the GPI.

## 4.6 DATA AND DATA QUALITY RULES

See Section A.5 of the GPI.

See Section 4.7 for further rules related to data and data quality per life-cycle stage and module D.

### 4.6.1 DATA CATEGORIES

See Section A.5.1 of the GPI.

### 4.6.2 DATA QUALITY REQUIREMENTS FOR PRIMARY DATA

See Section A.5.2 of the GPI.

### 4.6.3 DATA QUALITY REQUIREMENTS FOR REPRESENTATIVE SECONDARY DATA

See Section A.5.3 of the GPI.

### 4.6.4 DATA QUALITY ASSESSMENT AND DECLARATION

See Section A.5.4 of the GPI.

### 4.6.5 EXAMPLES OF DATABASES FOR SECONDARY DATA

All commercial or publicly available databases that meet the data quality requirements maybe used. The specifications and the version of the database shall be reported in the EPD.

## 4.7 OTHER LCA RULES

See Section A.6 of the GPI.

For specific LCA rules per life-cycle stage, see Section 4.8.



## INDUSTRIAL TRUCKS

PRODUCT CATEGORY CLASSIFICATION: UN CPC 4353 (EXCLUDING TRACTORS OF THE TYPE USED ON RAILWAY STATION PLATFORMS)

#### 4.7.1 MASS BALANCE

See Section A.6.1 of the GPI.

#### 4.7.2 ELECTRICITY MODELLING

See Section A.6.2 of the GPI.

#### 4.7.3 BIOGAS MODELLING

See Section A.6.3 of the GPI.

### 4.8 SPECIFIC RULES PER LIFE-CYCLE STAGE AND MODULE D

See Section A.7 of the GPI.

Below are further data quality requirements and other LCA rules per life-cycle stage, and for module D, of relevance for the product category.

#### 4.8.1 PRODUCT STAGE, A1-A3

See Section A.7.1 of the GPI.

If primary data are used for the production (e.g., from raw material to the finished component) of main parts of the Industrial Truck (e.g., steel, aluminium components, battery) the related PCRs for basic materials and fabricated products may be followed as reference, if available. For example:

- Basic Iron or Steel products: PCR2015:03 Basic iron or steel products & special steels, except construction products
- Basic Aluminium products: PCR 2022:08 Basic aluminium products and special alloys
- Fabricated metal products: PCR 2023:01 Fabricated metal products, except construction products

Regarding A2, i.e., transport of materials/components to the manufacturing, specific data shall be used for main components (e.g., axis, battery, engine, wheels) for at least 95% of Industrial Truck weight, based on the actual transportation mode and distances from suppliers.

The remaining minor components may be modelled according to fixed distances as follows, if no specific data are available or it is too time consuming to be collected:

- International transport: 20000 km by ship plus 1000 km by lorry,
- Intracontinental transport: 3500 km by lorry,
- Domestic transport: 1500 km by lorry,
- Local transport: 50 km by lorry.

If this option is adopted, the choice shall reflect the representative scenario and be justified

#### 4.8.2 DISTRIBUTION AND INSTALLATION STAGE, MODULES A4-A5

See Section A.7.2 of the GPI.

In addition, for A4, if the distribution to one specific customer/market is not representative or if customer/markets are too diversified, an average scenario referred to the representative distribution macro-area shall be adopted (e.g. Europe, America, Asia). It is allowed to add additional scenarios (max 3) in the Environmental Performance section.

The third option is a default transportation, if no specific data are available:

- International transport: 20000 km by ship plus 1000 km by lorry,
- Intracontinental transport: 3500 km by lorry,

## INDUSTRIAL TRUCKS

PRODUCT CATEGORY CLASSIFICATION: UN CPC 4353 (EXCLUDING TRACTORS OF THE TYPE USED ON RAILWAY STATION PLATFORMS)

- Domestic transport: 1500 km by lorry,
- Local transport: 50 km by lorry.

If the third option is adopted, the choice shall reflect the representative scenario and be justified

A5 may be set to zero if not relevant for the product. This choice shall be justified.

#### 4.8.3 USE STAGE, MODULES B1-B7

See A.7.3 of the GPI.

B modules shall be accounted for the lifespan (see Section 4.2.1).

Operation consumptions and maintenance shall be modelled according to a scenario based on manufacturer technical data sheets/actual data.

Consumptions may be calculated: Lifespan (h)\*kWh/h (according to VDI cycle and battery efficiency due to energy losses)

#### 4.8.4 END-OF-LIFE STAGE, MODULES C1-C4

See A.7.4 of the GPI.

If no specific data are available on transportation distances to waste treatment plant, a default distance of 1000 km by lorry may be used.

Assumptions on the end-of life scenario shall be documented in the LCA report and EPD.

#### 4.8.5 CONSEQUENCES FOR RECOVERED MATERIAL/ENERGY BEYOND THE PRODUCT LIFE CYCLE (MODULE D)

See A.7.5 of the GPI.

### 4.9 ENVIRONMENTAL PERFORMANCE INDICATORS

See Section A.8 of the GPI.

In addition, results for GWP-GHG and WDP shall be declared per each included module and in aggregated form (A1-A3, A-C) for 1 hour operation (i.e. dividing reported results by lifespan in hours).

### 4.10 SPECIFIC RULES PER EPD TYPE

#### 4.10.1 MULTIPLE PRODUCTS FROM THE SAME COMPANY

See Section A.9.1 of the GPI.

#### 4.10.2 SECTOR EPD

See Section A.9.2 of the GPI.

#### 4.10.3 EPD OWNED BY A TRADER

See Section A.9.3 of the GPI.

#### 4.10.4 EPD OF PRODUCT NOT YET ON THE MARKET

See Section A.9.4 of the GPI.

INDUSTRIAL TRUCKS

PRODUCT CATEGORY CLASSIFICATION: UN CPC 4353 (EXCLUDING TRACTORS OF THE TYPE USED ON RAILWAY STATION PLATFORMS)

#### 4.10.5 EPD OF PRODUCT RECENTLY ON THE MARKET

See Section A.9.5 of the GPI.

DRAFT

INDUSTRIAL TRUCKS

PRODUCT CATEGORY CLASSIFICATION: UN CPC 4353 (EXCLUDING TRACTORS OF THE TYPE USED ON RAILWAY STATION PLATFORMS)

## 5 CONTENT OF LCA REPORT

Data for verification shall be presented in the form of an LCA report – a systematic and comprehensive summary of the project documentation that supports the verification of an EPD. The LCA report is not part of the public communication.

See Section 8.3.1 of the GPI for rules on the content of the LCA report.

Note that there may be rules on the content of the LCA report elsewhere in the GPI or in this PCR.

DRAFT

INDUSTRIAL TRUCKS

PRODUCT CATEGORY CLASSIFICATION: UN CPC 4353 (EXCLUDING TRACTORS OF THE TYPE USED ON RAILWAY STATION PLATFORMS)

## 6 CONTENT AND FORMAT OF EPD

See Section 7 of the GPI.

### 6.1 EPD LANGUAGES

See Section 7.1 of the GPI.

### 6.2 UNITS AND QUANTITIES

See Section 7.2 of the GPI.

### 6.3 USE OF IMAGES IN EPD

See Section 7.3 of the GPI.

### 6.4 SECTIONS OF THE EPD

See Section 7.4 of the GPI.

#### 6.4.1 COVER PAGE

See Section 7.4.1 of the GPI.

#### 6.4.2 GENERAL INFORMATION

See Section 7.4.2 of the GPI.

#### 6.4.3 INFORMATION ABOUT EPD OWNER

See Section 7.4.3 of the GPI.

#### 6.4.4 PRODUCT INFORMATION

See Section 7.4.4 of the GPI.

#### 6.4.5 CONTENT DECLARATION

See Section 7.4.5 of the GPI.

In addition, the content declaration should report main components of the product (i.e. 90% of product weight) aggregated per material/ substance category (e.g. steel, aluminium, copper, battery, polymers, electronics) and the remaining weight as other, see an example in the figure below. The same shall be reported in a separate table for spare part replaced in B module (if included), see an example in the figure below.

The % of recycled material includes post and pre-consumer scraps and should be calculated on the weighted average of recycled materials used in each component

INDUSTRIAL TRUCKS

PRODUCT CATEGORY CLASSIFICATION: UN CPC 4353 (EXCLUDING TRACTORS OF THE TYPE USED ON RAILWAY STATION PLATFORMS)

Table 2. Example of content declaration of the product

| Materials | Mass % versus the product (excluding packaging weight) | % recycled material (post- and pre-consumer) | Biogenic material, kg C/ product |
|-----------|--------------------------------------------------------|----------------------------------------------|----------------------------------|
| Steel     | 70%                                                    | 60%                                          | 0%                               |
| Aluminium | 10%                                                    | 50%                                          | 0%                               |
| Rubber    | 5%                                                     | 10%                                          | 0%                               |
| Plastics  | 2%                                                     | 0%                                           | 0%                               |
| Metals    | 4%                                                     | 0%                                           | 0%                               |
| Other     | 7%                                                     | 0%                                           | 0%                               |
| TOTAL     |                                                        |                                              |                                  |

Table 3. Example of content declaration of spare parts replaced in module B

| Material  | Mass % versus the product (excluding packaging weight) | % recycled material (post- and pre-consumer) | Biogenic material, kg C/ product |
|-----------|--------------------------------------------------------|----------------------------------------------|----------------------------------|
| Steel     | 1%                                                     | 60%                                          | 0%                               |
| Rubber    | 1%                                                     | 50%                                          | 0%                               |
| Aluminium | 0.5%                                                   | 0%                                           | 0%                               |

### 6.4.6 LCA INFORMATION

See Section 7.4.6 of the GPI.

### 6.4.7 ENVIRONMENTAL PERFORMANCE

See Section 7.4.7 of the GPI.

The EPD shall declare the environmental performance indicators listed or referred to in Section 4.9, per functional unit, per life-cycle stage and module D.

Additional (max 3) scenarios for alternative distribution / use / end of life may be reported in a separate subsection of the Environmental Performance section (e.g., 1 scenario for distribution / use / end of life in Europe, 1 scenario for distribution / use / end of life in Asia, 1 scenario for distribution / use / end of life in North America). In this case, modules A4-C4 shall be aligned.

### 6.4.8 ADDITIONAL ENVIRONMENTAL INFORMATION

See Section 7.4.8 of the GPI.

### 6.4.9 ADDITIONAL SOCIAL AND ECONOMIC INFORMATION

See Section 7.4.9 of the GPI.

### 6.4.10 INFORMATION RELATED TO SECTOR EPDS

See Section 7.4.10 of the GPI.

INDUSTRIAL TRUCKS

PRODUCT CATEGORY CLASSIFICATION: UN CPC 4353 (EXCLUDING TRACTORS OF THE TYPE USED ON RAILWAY STATION PLATFORMS)

#### 6.4.11 VERSION HISTORY

See Section 7.4.11 of the GPI.

#### 6.4.12 ABBREVIATIONS

See Section 7.4.12 of the GPI.

#### 6.4.13 REFERENCES

See Section 7.4.13 of the GPI.

DRAFT

INDUSTRIAL TRUCKS

PRODUCT CATEGORY CLASSIFICATION: UN CPC 4353 (EXCLUDING TRACTORS OF THE TYPE USED ON RAILWAY STATION PLATFORMS)

## 7 LIST OF ABBREVIATIONS

|     |                                                |
|-----|------------------------------------------------|
| CPC | Central product classification                 |
| EPD | Environmental product declaration              |
| GPI | General Programme Instructions                 |
| ISO | International Organization for Standardization |
| LCA | Life cycle assessment                          |
| PCR | Product category rules                         |
| RSL | Reference service life                         |
| UN  | United Nations                                 |

DRAFT



INDUSTRIAL TRUCKS

PRODUCT CATEGORY CLASSIFICATION: UN CPC 4353 (EXCLUDING TRACTORS OF THE TYPE USED ON RAILWAY STATION PLATFORMS)

## 8 REFERENCES

CEN (2021) EN 15804:2012+A2:2019/AC:2021, Sustainability of construction works – Environmental product declarations – Core rules for the product category of construction products.

EPD International (2024) General Programme Instructions for the International EPD System. Version 5.0.0, dated 2024-06-19. Available on [www.environdec.com](http://www.environdec.com).

ISO (2006a) ISO 14025:2006, Environmental labels and declarations – Type III environmental declarations – Principles and procedures.

ISO (2006b) ISO 14040:2006, Environmental management – Life cycle assessment – Principles and framework.

ISO (2006c) ISO 14044: 2006, Environmental management – Life cycle assessment – Requirements and guidelines.

ISO (2015a) ISO 14001:2015, Environmental management systems – Requirements with guidance for use.

ISO (2015b) ISO 9001:2015, Quality management systems – Requirements.

ISO (2017) ISO 21930:2017, Sustainability in buildings and civil engineering works – Core rules for environmental product declarations of construction products and services.

ISO (2018b) ISO/TS 14067:2018, Greenhouse gases – Carbon footprint of products – Requirements and guidelines for quantification and communication.

ISO (2020) ISO 5053-1:2020, Industrial trucks — Vocabulary — Part 1: Types of industrial trucks

KION, 2024 CFP Report - KION Linde N20, Rev.1

PCR 2010:08 Other special- and general-purpose machinery and parts thereof v.4.0, published 2022-04-04

PCR2015:03 Basic iron or steel products & special steels, except construction products

PCR 2022:08 Basic aluminium products and special alloys

PCR 2023:01 Fabricated metal products, except construction products

INDUSTRIAL TRUCKS

PRODUCT CATEGORY CLASSIFICATION: UN CPC 4353 (EXCLUDING TRACTORS OF THE TYPE USED ON RAILWAY STATION PLATFORMS)

## 9 VERSION HISTORY OF PCR

VERSION 1.0.0, 20YY-MM-DD

Original version of the PCR

DRAFT

INDUSTRIAL TRUCKS

PRODUCT CATEGORY CLASSIFICATION: UN CPC 4353 (EXCLUDING TRACTORS OF THE TYPE USED ON RAILWAY STATION PLATFORMS)

## 10 ANNEX 1

The following pictures show example of industrial trucks included in the scope of this PCR (pictures from ISO 5053-1:2020)

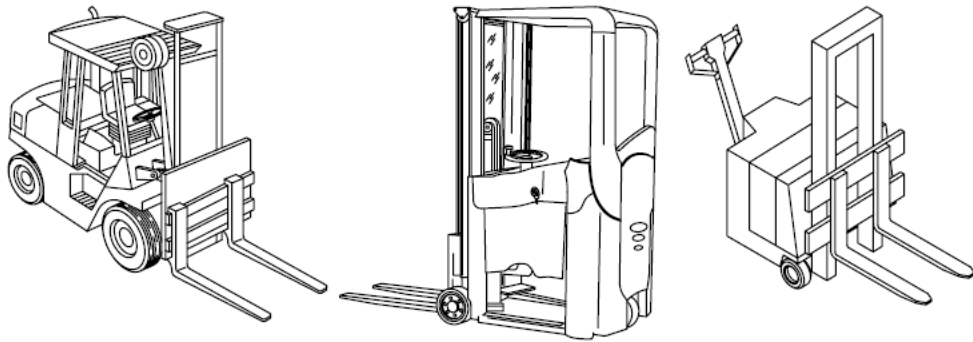

Figure 3. Counterbalance lift truck

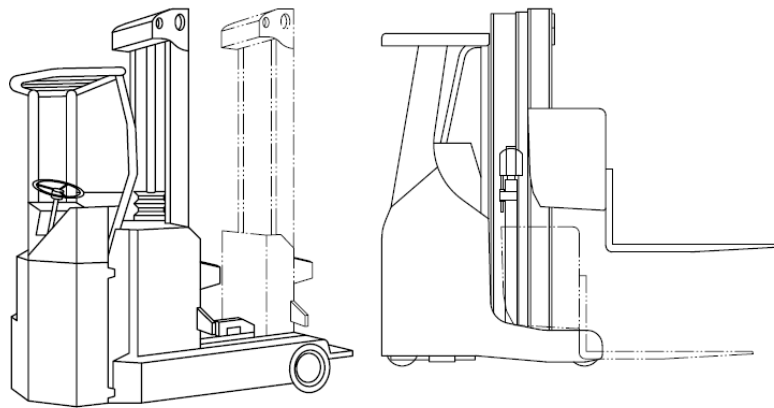

Figure 4. Reach truck

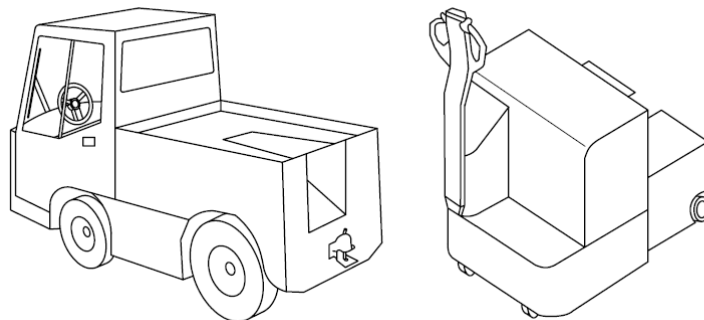

Figure 5. Towing tractor

INDUSTRIAL TRUCKS

PRODUCT CATEGORY CLASSIFICATION: UN CPC 4353 (EXCLUDING TRACTORS OF THE TYPE USED ON RAILWAY STATION PLATFORMS)

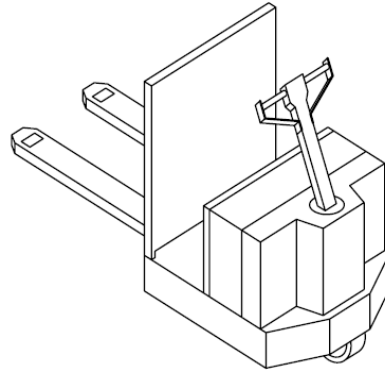

Figure 6. Centre-controlled order-picking truck

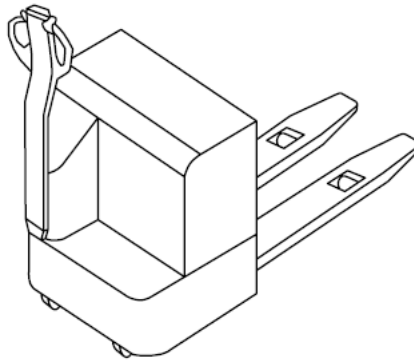

Figure 7. Pallet truck

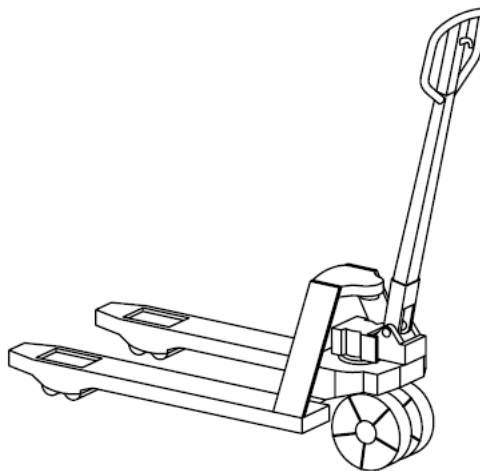

Figure 8. Pedestrian-propelled pallet truck

INDUSTRIAL TRUCKS

PRODUCT CATEGORY CLASSIFICATION: UN CPC 4353 (EXCLUDING TRACTORS OF THE TYPE USED ON RAILWAY STATION PLATFORMS)

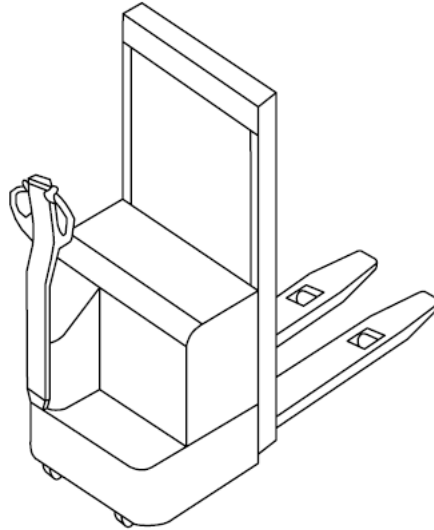

Figure 9. Pallet-stracking truck

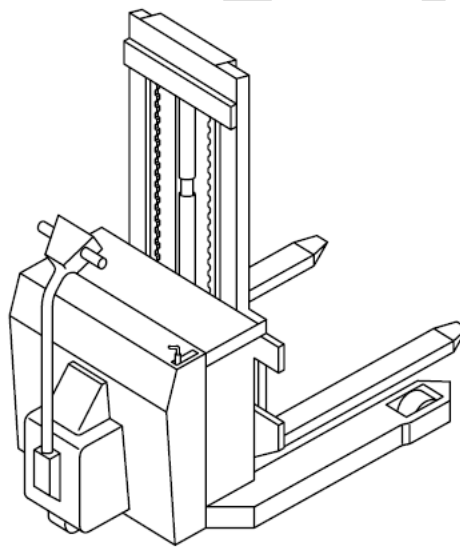

Figure 10. Straddle truck

INDUSTRIAL TRUCKS

PRODUCT CATEGORY CLASSIFICATION: UN CPC 4353 (EXCLUDING TRACTORS OF THE TYPE USED ON RAILWAY STATION PLATFORMS)

DRAFT

© EPD INTERNATIONAL AB 2025

YOUR USE OF THIS MATERIAL IS SUBJECT TO THE GENERAL TERMS OF USE PUBLISHED ON BY EPD INTERNATIONAL AB:S HOMEPAGE ON [WWW.ENVIRONDEC.COM](http://WWW.ENVIRONDEC.COM). IF YOU HAVE NOT REGISTERED AND ACCEPTED EPD INTERNATIONAL AB:S THE GENERAL TERMS OF USE, YOU ARE NOT AUTHORIZED TO EXPLOIT THIS WORK IN ANY MANNER.

COVER IMAGE © *TO BE ADDED BY THE SECRETARIAT IN THE PCR*

