

FIVE PRO

FIVE PRO advanced managerial armchair with mesh backrest characterized by essential shapes, able to grant high functional and comfort performance.

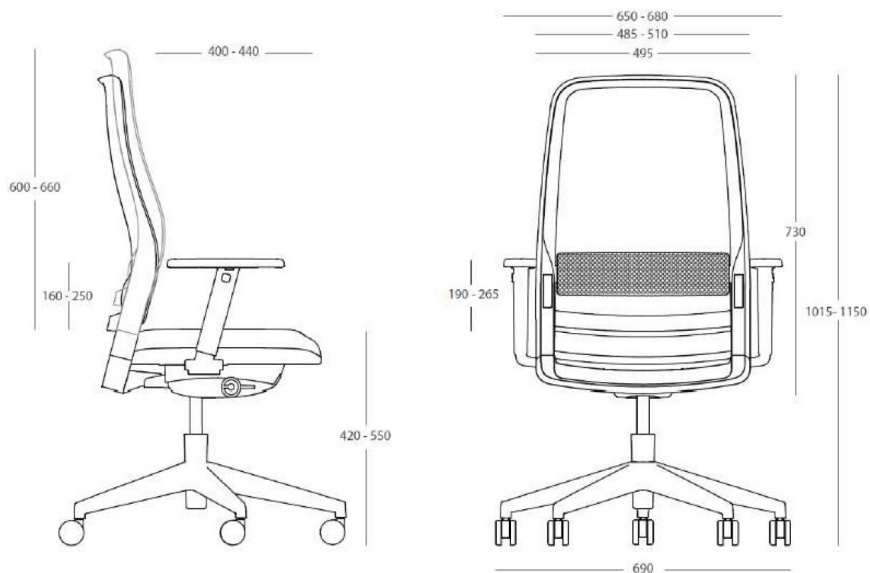

DIMENSIONS



FIVE PRO

SEDILE & SCHIENALE

Managerial armchair with double-track Up & Down adjustable backrest to grant stability, and an additional height-adjustable lumbar support.

The backrest is made of a high-resistance black polypropylene frame that welcomes the polyurethane foam padding. The external backrest in polypropylene is equipped with height-adjustment lumbar support.

The seat is realized with high-resistance recycled polypropylene under-seat cover – thickness 2,5 mm – equipped with 2 steel bars to enhance the resistance.

OPTIONAL

1. Sliding seat

PADDING

The seat is made of non-deformable polyurethane density 40 thickness 5 cm.

The backrest is made of non-deformable cold injected foam density 40 thickness 3 cm.

Fire-retardant version available.

MECHANISM

Five pro is equipped with self-weighting mechanism with 5 lock positions.

M12 synchron mechanism made of black aluminum, height adjustable seat and synchronized adjustment of seat/ backrest with antishock system, 5 lock positions.

Tilt adjustment through an under-seat lever.



Gas lift in compliance with DIN 4550 – 4th level.

BASE

Five pro is available with 2 different 5-spoke bases on castors (standard in black nylon 65 mm):

“LOOP” black polypropylene base. [d. 680 mm]

“LOOP” polished aluminium base. [d. 680 mm]

Optional proposed with the same fastening kit diam. 11 mm:

Black (R06) or grey with chromed carter (R06) rubber castors

Rubber and self-breaking castors (R06A)

“Polo” rubber castors with central hole

Black nylon feet (R08)

FIVE PRO

ARMRESTS

1. Fixed black polypropylene armrests
2. Height-adjustable black polypropylene armrests
3. Height and width adjustable black polypropylene armrests with soft polyurethane surface
4. 3D adjustable black polypropylene armrests with soft polyurethane surface
5. 3D adjustable aluminium armrests with black polypropylene carter and soft polyurethane surface

CERTIFICATIONS

1. EN1335-A
2. 1IM FIRE RETARDANT
3. CAM



FIVE PRO

UPHOLSTERY

CREPE'

CATEGORY 1

350 gr/mtl
100% Polyester Class 1 ,EN1021/1-2
50.000 +/- 10% cycles

BIO-EXPO

CATEGORY 2

300 gr/mt2
100% Propitex FR bacteriostatic
Class 1UNI EN ISO 354:2003
100.000 +/- 10% cycles Martindale

EXTREME

CATEGORY 2

350 gr/mtl
100% Xtreme FR
Class 1 , EN 1021-1/2
100.000 +/- 10% cycles Martindale

LASER

CATEGORY 2

560 gr/mtl
100% Polyester FR
Class 1
80.000 +/- 10% cycles Martindale

ECOPELLE

CATEGORY 2

630 gr/mt2
83% PVC, 17% Synthetic
ISO 379-DIN75200-CSERF4/83 10%
cycles Martindale

ERA

CATEGORY 3

448 gr/mtl
100% Trevira CS
Class 1UNI EN ISO 354:2003
100.000 +/- 10% cycles Martindale

LASER PLUS

CATEGORY 3

630 gr/mtl
100% Polyester FR Trevira
Class1 , 4.000 +/- cycles Martindale

ECOPELLE SOUL

CATEGORY 3

760 gr/mt2
Superficies 100% POLYURETHANE,
Base Polyester 85%,17% Cotton
EN1021-1/BSS852 PART 1
>100.000 EN ISO 5470-2

MELANGE

CATEGORY 3

390 g/lin.m
100% Trevira CS
Class 1
80.000 +/- 10% cycles Martindale

JET

CATEGORY 3

365 +/- 5% g/lin.m
100% Polyester FR
Class 1
80.000 +/- 10% cycles Martindale

ECOPELLE SISTEMA PRO

CATEGORY 3

710 gr/mt2
Surface 93% PVC
Base Polyester 28%
CLASS1
100.000 CYCLES

ECOPELLE VITAX

CATEGORY 3

850 gr/mt2
Surface 98% PVC 2% PU
Base cotton 100%
CLASS 1
100.000 CYCLES

ONE RECYCLE

CATEGORY 3

525 gr/mt2
100% recycled polyester
Base cotton 100%
CLASS 1IM
100.000 CYCLES

LANA

CATEGORY 5

500 gr/mt2
75% Lana, 25% polyamide
Class 1
100.000 cycles Martindale

PELLE

CATEGORY 5/6

620 g/lin.m
100% Cow leather
Class 1, EN 1021-1/2

PIED POULE

CATEGORY 6

550 g/lin.m
66% cotton, 34% Polyester
35.000 % cycles Martindale

EUROPOST 2

CATEGORY 6

710 g/lin.m
63% PU, 16% CO, 21% PL
Ini1975 CLASS1emme,UNI9175/FA
50.000% cycles Martindale

PREMIUM /ELEGANCE

CATEGORY 7

100% First quality cow leather
Thickness 1,2/1,4 mm
EN1021-1/2

STEELCUT TRIO

CATEGORY 7

770 g/lin.m
90% New wool worsted, 10% Nylon
Class 1, EN 1021-1/2
100.000 % cycles Martindale

REMIX

CATEGORY 7

415 g/lin.m
90% New wool worsted, 10% Nylon
Class 1, EN 1021-1/2
100.000 % cycles Martindale

VELLUTO DECONTRACTE'

CATEGORY 7

590 g/lin.m
19% CO, 61% PC,10% PL, 10%VI
40.000 % cycles Martindale

MERIT

CATEGORY 7

500g/lin.m
76% Polyester Recycled
24% Polyester
EN 1021-1/2
85.000 % cycles Martindale

VELLUTO

CATEGORY 8

600 g/lin.m
100.000 % PL Flame retardant

PELLE SOFT

CATEGORY 8

100% Cow leather Thickness,8-2 mm
Aniline treatment – First quality
EN1021-1/2

GABRIEL MESH

510 gr. gr/mtl
100% Polyester / Polyester
BS EN 1021-1:2014
70.000 / rub

FIVE PRO

GOAL MESH

350 gr/ mq
100% Polyester CL. 1
100.000 Martindale cycles

USAGE AND MAINTENANCE

In order to have an optimal maintenance of the products and to preserve the characteristics of the materials by which they are made, it is recommended the following course of action.

FABRICS

Cleaning: check the dedicated selection written on the color Swatch card.

Usage: it is recommended to pay careful attention to the fabrics as they can be cut or ripped easily.

WOODS

Cleaning: clean using a soft cloth, soaked in tepid water. Dry always after the cleaning. Remove immediately any liquid substances or other residue in order to prevent the absorption.

Usage: wooden surfaces, being a natural material, might be subjected to color alterations with sun exposure and use over time. It is reminded that wooden surfaces cannot endure direct heat sources.

METALS

Cleaning: both steel and aluminum surfaces, and the painted ones, have to be cleaned using a soft cloth soaked in tepid water. For the most persistent stains it is possible to dilute mild soap with water moderately. Dry always after the cleaning, using a soft cloth of deer-hide. Do not use cleaning products for steel, chlorine, bleach or other strong products. It is not recommended to use abrasive, scourers, which can scratch the metal surfaces.

Usage: pay attention to the food stains as coffee, coke, fruit juices that can make indelible marks on the surfaces.

WARRANTY

QUINTI guarantees the products will maintain their properties for 6 years from delivery, except normal usury and provided that they will be used according to the guidelines given. QUINTI will replace, free of charge, any product found non-compliant with this warranty, without incurring any other liability of sort. Components, external accessories or materials supplied by the buyer and applied to the products in order to customize them will not be supported by the guarantee. For an optimal maintenance of the products and to keep unchanged the characteristics of the materials with which they are made, some simple attentions are necessary.
