

# WELLAIR

## QUICK START GUIDE

# NanoDetect PRO

REV 1/2026

NanoDetect PRO (Wi-Fi): SKU 100080

NanoDetect PRO-S (Cellular): SKU 100081



[wellairsolutions.com](http://wellairsolutions.com)



## GET STARTED

This QuickStart guide aims to help you with the initial setup of your NanoDetect, where it's connected to NanoView. For local only installations, reference the Resources section, where you can find setup instructions for all different installation types.

## PHASE 1: DIGITAL PREP

### App Download

Download the NanoView App to begin setting up. This is required for local and networked setups.

The WellAir NanoView App can be downloaded from Google or Apple app store.



### Dashboard Access

To access the NanoView Dashboard, navigate to the following link and log in using your assigned credentials: <https://cloud.wellairsolutions.com/#/login>

## PHASE 2: HARDWARE SETUP

### WHAT'S IN THE BOX

Each NanoDetect PRO or PRO-S package contains the following components:

1. (1) NanoDetect PRO device
2. (2) mounting brackets
3. (2) screws
4. (1) sensor capsule
5. (1) USB cable and US adaptor plug
6. (1) Installation manual

### SAFETY PRECAUTIONS

Failure to adhere to these instructions may result in device malfunction or damage.

- Do not disassemble or modify the device  
Keep the device away from open flames, heat, cold, and liquid sources.
- This device is not intended as a reference monitor; WellAir/Plasma Air will not be liable for any damage caused by inaccurate readings.
- Avoid shocks or impacts to the device.

**WARNING: Do not connect to power before installation is complete.**

### HARDWARE OVERVIEW

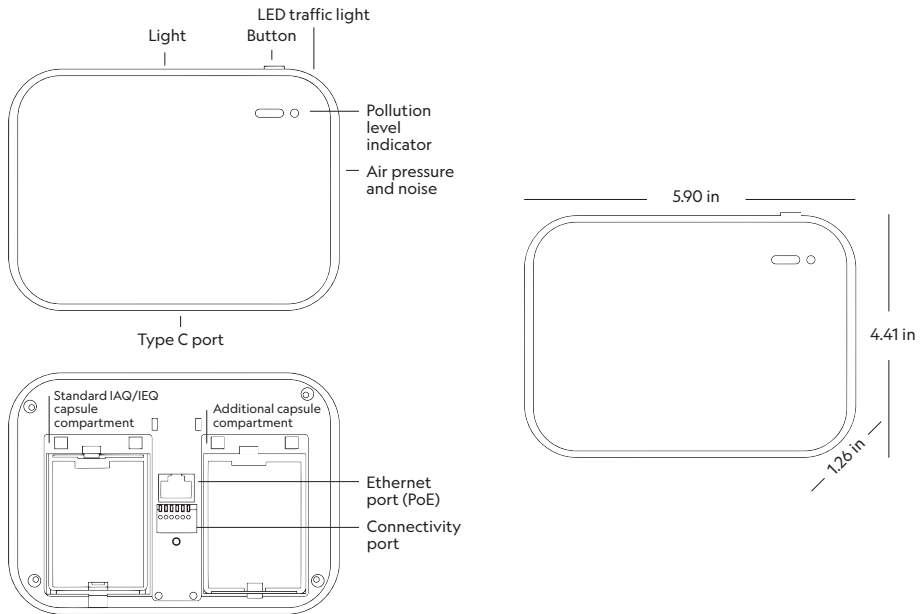

## CAPSULE INSTALLATION:

### Step 1

Pop off the capsule cover. Please note that a flat screwdriver may be needed if the capsule covers are tight.

### Step 2

Insert the sensor at a 30-degree angle into the designated slot. Once aligned, press down on the top side of the capsule to secure it in place.

### Step 3

Position the cover over the capsules and press down firmly on the upper part to ensure a secure fit.

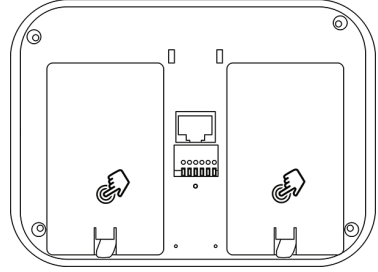
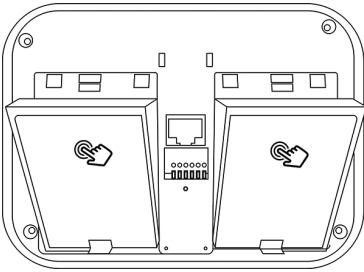

## MOUNTING

Mount the NanoDetect PRO device to wall in line with customer or building scheme requirements which are typically:

- 3.6 ft to 5.6 ft (1.1m to 1.7m) above the floor
- Clear of doors, windows and air vents
- Close to a power source

### 1. DRY WALL

- a. Attach the small bracket to the device with screws
- b. Mount bracket A on the wall
- c. Slide the device onto bracket A for secure placement

### 2. ELECTRICAL BOX MOUNT - REGIONAL VARIATIONS

- a. Line up the plate with your in-wall electrical box and mount it in place using Electrical Box Screws (vertical for US and horizontal for EU as per dry wall mount).

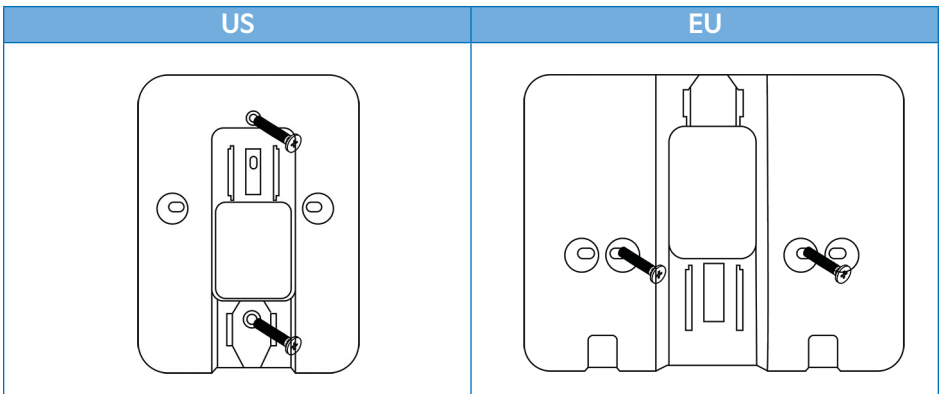

b. Slide the device into the wall-mounted brackets until securely positioned.

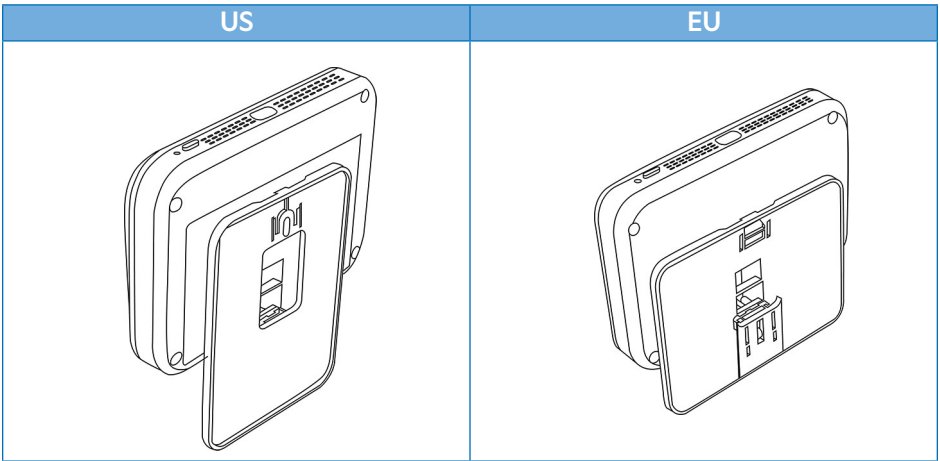

#### WARNING

- Please ensure that the power to the electrical box is turned off.
- Follow all local and national electrical and building codes.
- Do not connect to power before mechanical installation is complete.

### PHASE 3: POWER & CONNECTIVITY

#### POWER SUPPLY OPTIONS

The Sensor supports multiple power options for flexible installation:

- Type C (cable and adaptor/plug included)
- 24V AC
- 10-30V DC
- PoE (Power over Ethernet) Recommended: Simple single-cable installation

Connect the necessary power and connectivity cables:

- Power Cable
  - Connect 10-30V DC or 24V AC to the +/- terminals on the connectivity port.
  - For Power over Ethernet (PoE), connect to the Ethernet port
- Connectivity Cables
  - Connect Modbus or BACnet cables to the A/B terminals on the connectivity port.
  - Connect the Ethernet cable to the Ethernet port.

## DEVICE WI-FI ONBOARDING

1. Open the NanoView App on your mobile device.
2. Create or log in to your account.

If this is your first time using the app, follow prompts to create a username and password. Returning users can log in with existing credentials.

3. Enable Bluetooth access

Confirm that Bluetooth is turned on and shared with the NanoView App when prompted.

4. Start the Add Device process

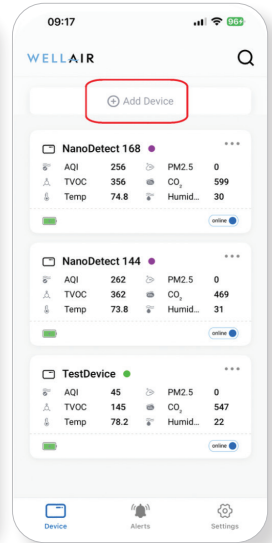
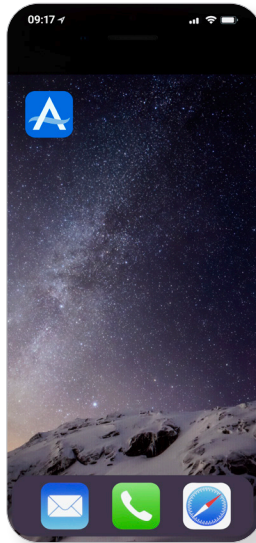

5. Select the device type

On the next screen, select NanoDetect PRO

6. Choose Wi-Fi setup

Select the option to add the device using a Wi-Fi network.

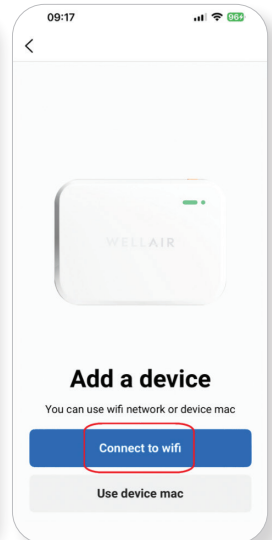
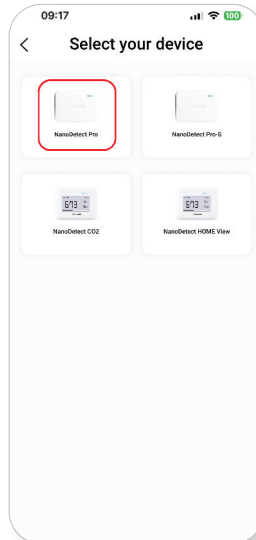

## 7. Review Wi-Fi and device status

The app will display your current Wi-Fi connection and device status. When ready, tap **Next Step**.

## 8. Select your sensor

A list of available sensors will appear. Identify your sensor by matching:

- Device model (e.g. NanoDetect PRO)
- Serial number (located on the product label on the back of the sensor)

Select the correct device from the list.

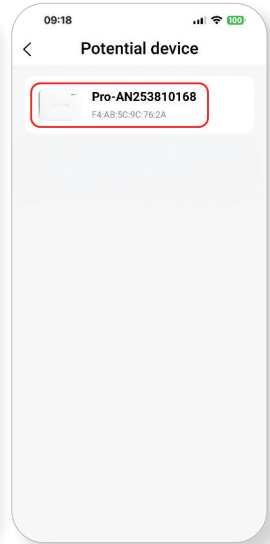
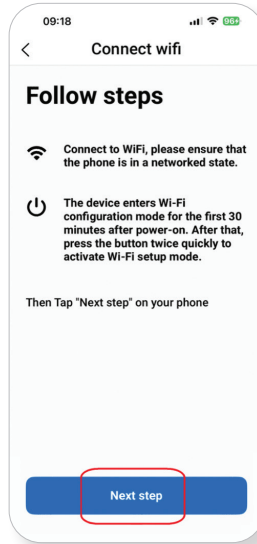

## 9. Enter Wi-Fi credentials

Confirm the Wi-Fi network name (SSID), enter the network password, and tap **Connect**.

## 10. Confirm successful connection

Once the setup is complete, the sensor will appear on the main **Devices** screen, indicating it is successfully connected to the Wi-Fi network.

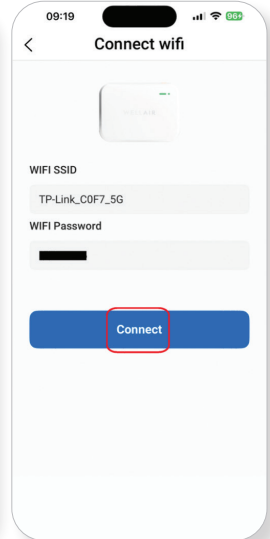
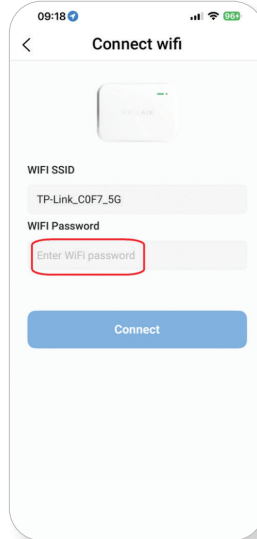

For information on other onboarding options, see link below:  
[NanoView App Guide | WellAir NanoDetect PRO](#)

## TROUBLESHOOTING

The troubleshooting guide can be accessed using the link:  
<https://www.wellairsolutions.com/news/troubleshooting>

## RESOURCES

For more information, guides and resources, please visit our dedicated support portal:  
<https://www.wellairsolutions.com/support-center-nanodetect-pro>

## DECLARATION of CONFORMITY

The NanoDetect PRO series meets essential requirements for CE, FCC, RoHS, and REACH certifications.

FCC ID XMR2023FCM362K

This device complies with part 15 of the FCC Rules. Operation is subject to the following two conditions:

- (1) This device may not cause harmful interference, and
- (2) This device must accept any interference received, including interference that may cause undesired operation.

---

European Union Importer:

**Novaerus (Ireland) Limited**

DCU Innovation Campus  
Old Finglas Road, Glasnevin,  
Dublin D11 KXN4, Ireland  
+353 1 907 2750

**Plasma Air International LLC**

3540 Toringdon Way, Suite 200,  
Charlotte, NC 28277  
1.866.508.1118  
info@wellairsolutions.com



