

# 75F<sup>®</sup> HyperStat<sup>™</sup> BACnet

Thermostat and humidistat with 8 on-board sensors for IAQM and efficiency in buildings with an existing BMS

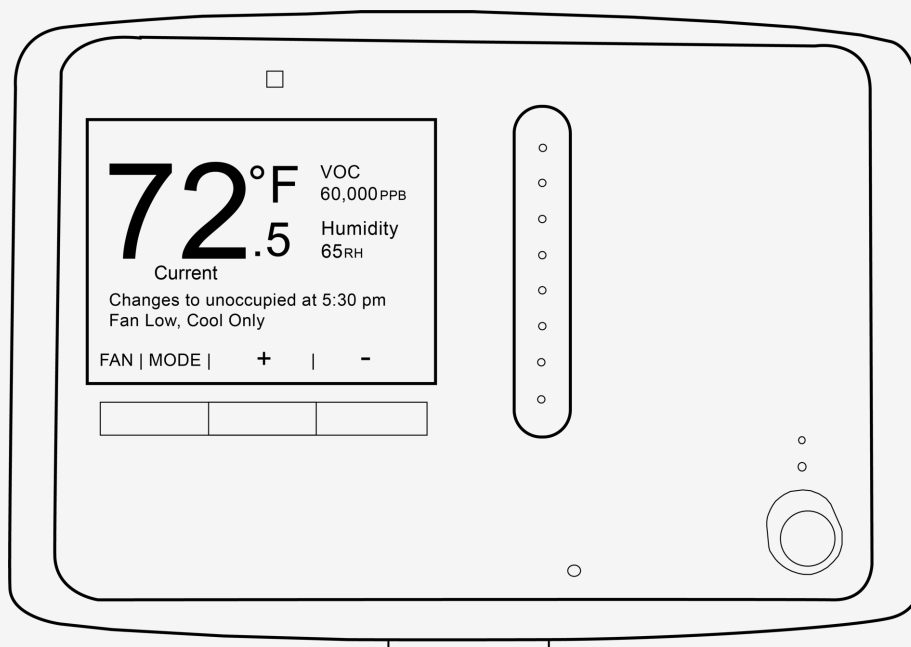

- Occupancy, temperature, VOC, light, humidity, sound, CO<sub>2</sub> and optional particulate matter
- TFT LCD display with touch slider and user buttons
- (6) Onboard relays
- (3) Analog outputs
- (2) Thermistor inputs
- (2) Analog inputs

# 75F® HyperStat™ BACnet

Give your occupants the power of IAQ management and localized temperature control with 75F's HyperStat, an all-in-one thermostat and humidistat thoughtfully crafted to support healthy, comfortable spaces. Each stat has up to eight on-board sensors for a complete picture of IAQ in your zone and has control capabilities for two-stage equipment to fine-tune sequences for optimal building health.

The HyperStat BACnet forgoes its online capabilities to bring the best IAQM and efficiency to buildings with an existing BMS.

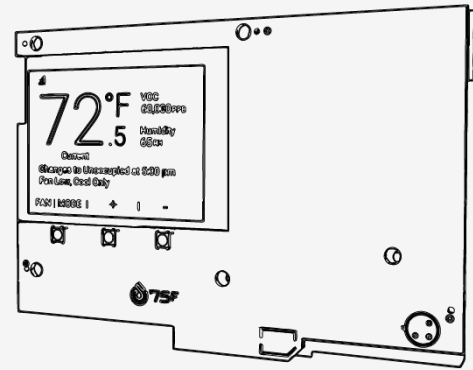

## OVERVIEW

The 75F® HyperStat™ with BACnet MSTP is a wired (RS-485) thermostat, humidistat, and IAQ sensing station. It comes with an industry-leading eight onboard sensors for occupancy, temperature, humidity, VOCs, light, sound, CO2 and PM2.5 to support the WELL Building Standard.

The standard HyperStat works out of the box with 75F's IoT BMS, delivering IAQ data every 60 seconds for seamless digital twin integration. With BACnet MSTP, it can be integrated into an existing BMS without the online features such as wireless communication and cloud-connected data.

## KEY FEATURES

- Data that complies with the WELL Building Standard, right out of the box.
- Built-in sequences for occupancy detection mean your HyperStat prioritizes health and comfort when it matters most and saves valuable energy when spaces are empty.
- Industry-leading connectivity allows interfacing to a wide variety of staged and fully modulating equipment.

## EQUIPMENT CONTROL

Up to five stages of cooling/heating/fan or fully modulating:

- Unit Heaters
- Water Source Heat Pumps
- Rooftop Units
- PTAC Units
- 4-Pipe Fan Coil Units
- 2-Pipe Fan Coil Units
- Induction Units

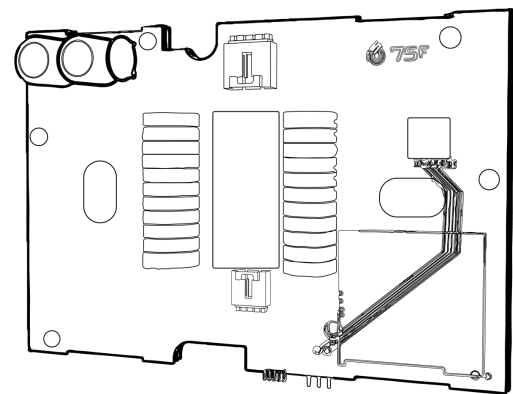

## INCLUDED

- 
- (1) Black or white HyperStat
- 
- (1) 10K type-2 thermistor with 30' cable
- 
- (2) Mounting screws
-

# 75F<sup>®</sup> HyperStat<sup>™</sup> BACnet

## MECHANICAL

<b>Dimensions</b>	165mm x 115mm x 29 mm (6.5" x 4.5" x 1.15")
<b>Mounting</b>	(2) screws in drywall
<b>Screen</b>	2.8" 240x320 pixel TFT LCD
<b>Operating Range</b>	0 to 122 F (-17 to 50 C)

## SENSORS

<b>Temperature</b>	Operating range between 0 to 122°F; typical accuracy of +/- 0.2C
<b>Humidity</b>	Operating range between 20 to 80% noncondensing; Typical accuracy of +/- 2% RH
<b>Dedicated CO<sub>2</sub> Sensor</b>	Range 0-40'000 ppm; Accuracy +/-30ppm; drift +/- 50ppm over range of 400-5000ppm and lifetime of 15 years
<b>VOC sensor</b>	TVOC: 0-60'000 ppb. Typical Accuracy - 15% of measured value
<b>Light</b>	Ambient light sensor; high-accuracy UV index sensor; matches erythemal curve; < 100 mix resolution
<b>Sound</b>	40-120dB response for 100 Hz to 10Khz
<b>Occupancy</b>	Passive Infra Red (PIR) with detection range of 4m with 30-degree angle

## OPTIONAL SENSORS

<b>PM2.5, PM10</b>	Detection range of 0-1000ug/m3 and accuracy of +/- 10ug/m3 (PM2.5, 0-100 ug/m3) or +/- 25ug/m3 (PM10, 0-100ug/m3)
--------------------	---

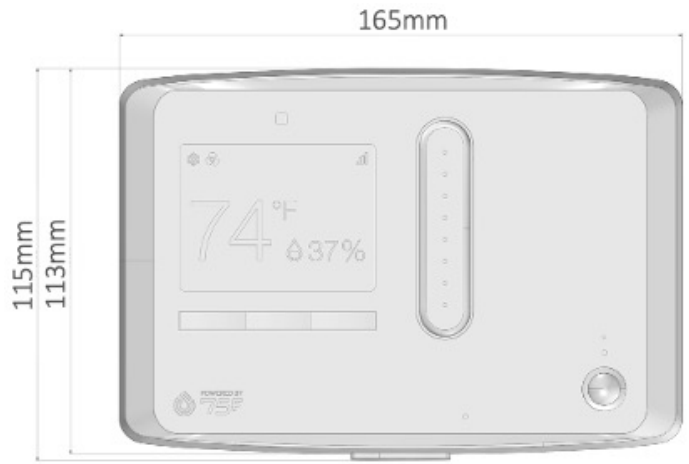

## ELECTRICAL

<b>Power</b>	24V AC/DC (+/-15%) with nominal power consumption 1.0W and maximum consumption of 2.5W
--------------	--

## COMMUNICATIONS

<b>Wired</b>	4 wire RS-485 interface 3 wire connector for low-power sensor bus
--------------	--

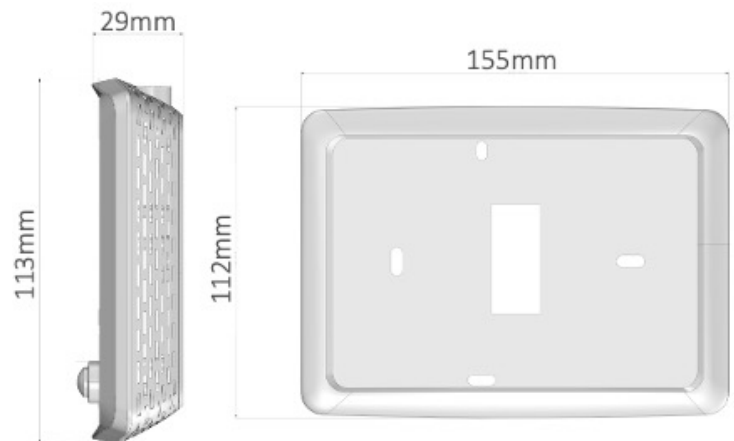

# 75F® HyperStat™ BACnet

## I/O

<b>Inputs</b>	(2) 10k type-2 thermistor inputs with 2% accuracy (2) 0-10V analog voltage inputs with 2% detection accuracy
<b>Outputs</b>	(6) Relays rated at 110V ac, 24V dc/1A (3) 0-10V/4 -20ma (max load of 20mA per channel) analog outputs

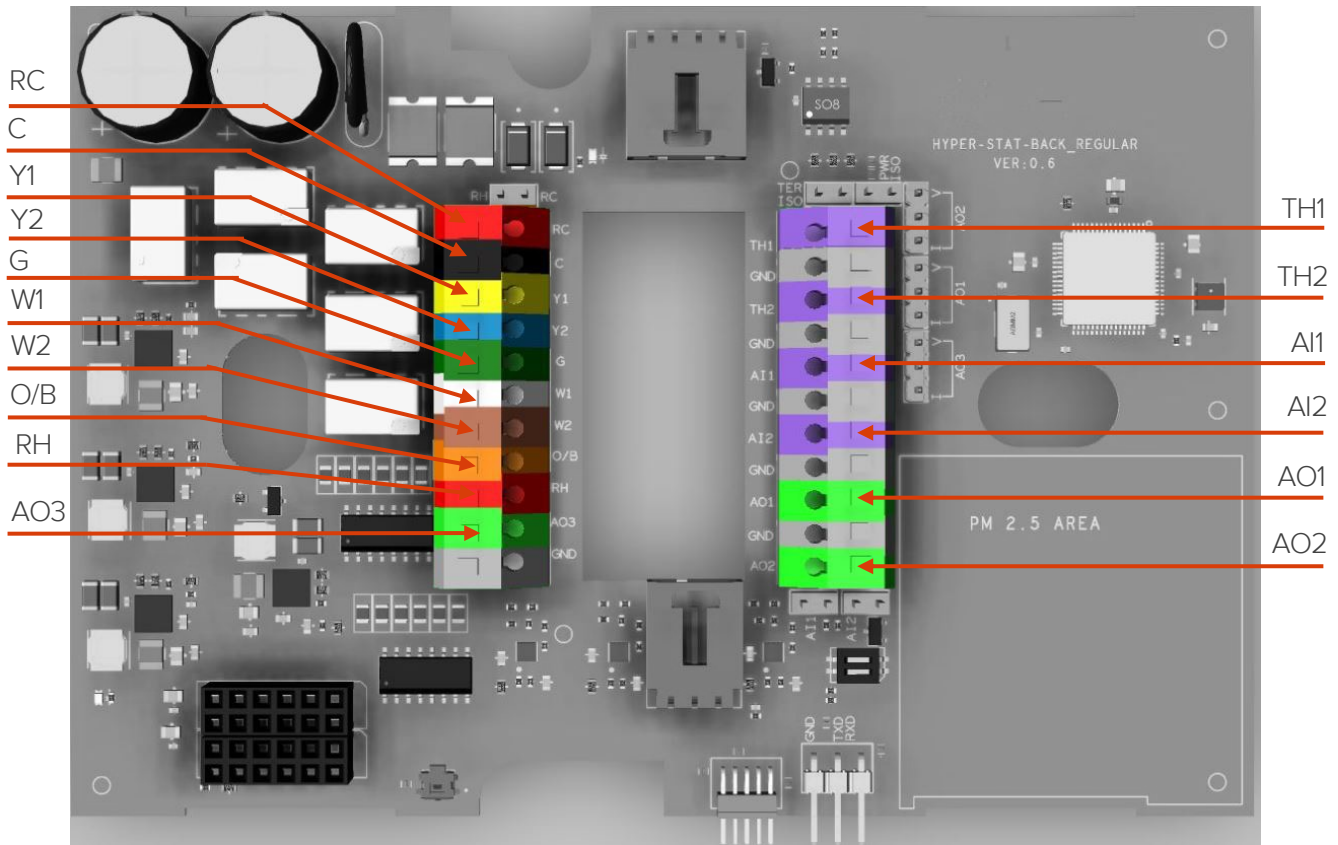

## WALL PLATE

**Dimensions** 165mm x 113 mm (6.5" x 4.5")