

IDA-X

Sugar and sugarfree
coating



AUTOMATIC SUGAR
COATING INSTALLATION:
THE PERFECT COMBINATION
OF DESIGN AND KNOW-HOW
FOR THE BEST
QUALITY PRODUCTS

IMPROVED PRODUCTIVITY,
FLEXIBILITY AND CONSISTANCY
WITH LOWER LABOUR AND
ENERGY COSTS

Dumoulin





IDA-X

FULL AUTOMATIC
COATING
INSTALLATION
FOR SUGAR
AND SUGARFREE
COATING

IDA-X

FULL AUTOMATIC INSTALLATION FOR SUGAR AND SUGARFREE COATING

Machine type	502X	1002X	2002X	3002X
Useful volume (liters)	650	1300	2600	3900
Batch size (kg)	250-500	500-1000	1000-2000	2000-3000
Drum diameter (mm)	1600	1600	1800	1900
Drum length (mm)	1600	2900	4200	5600
Bed depth (mm)	450	450	540	630

PRODUCTS RANGE

A wide range of centers

- Dried fruits, seeds, nuts...
- Toffees, caramels, liquorices...
- Biscuits, extruded products
- Chewing gums and chewy candies

A wide range of coatings

- Any type of syrup, sucrose, dextrose
- All polyols
- Dry powders, icing sugar...
- Waxing, glazing, varnishing



DRUM DESIGN

Fully perforated drum

- Suitable for hard sugar coat, sugarless coat, glazing or varnishing
- Air flow through products bed
- Low pressure drop for better efficiency
- Faster drying time



Shallow bed depth

- Elongated drum shape for lower bed depth
- Careful handling of fragile products
- Better mixing
- Better exposure to ventilation and spraying

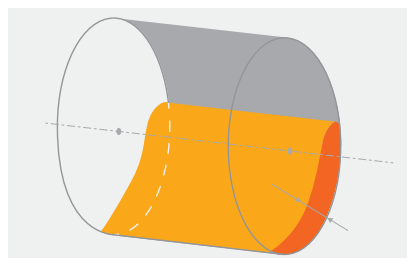

SYRUP SPRAYING

Syrup preparation

- Modular custom design
- Hot or cold solutions with various ingredients, gum, gelatine, starch, colour, flavour...

Syrup dosing and spraying

- High accuracy and consistency, with lobes pump and flowmeter
- Double jacketed networks
- Spraybar extraction for easy maintenance
- Spray nozzles automatic cleaning

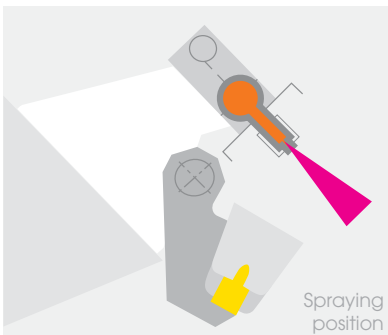
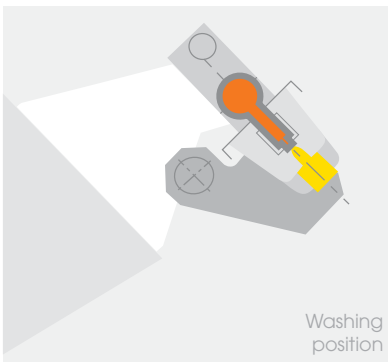

POWDER DISTRIBUTION

To help crystallization

for coating with polyols

To cover products

with cocoa powder, icing sugar...

Accurate system

with powder dosing / weighing and compressed air powder transport

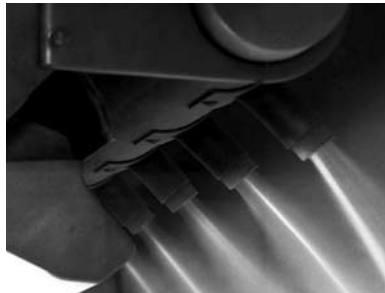
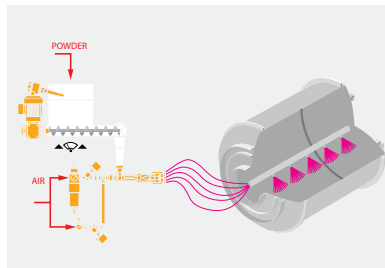

VARNISHING AND WAXING

Varnishing solution tanks

For aqueous and alcoholic solution

Varnish dosing systems

for controlled steps

Varnish spraying systems in the pan

with airless spray guns

Micronised carnauba wax distribution

with air spray system



AIR TREATMENT GROUP

Process Air

- Airflow, temperature and humidity control
- Perfect repeatability

Machine type	502X	1002X	2002X	3002X
Airflow (m ³ /h)	4500	9000	18000	27000

Exhaust Air

- Negative pressure inside pan
- Automatic cleaning
- Dust collection

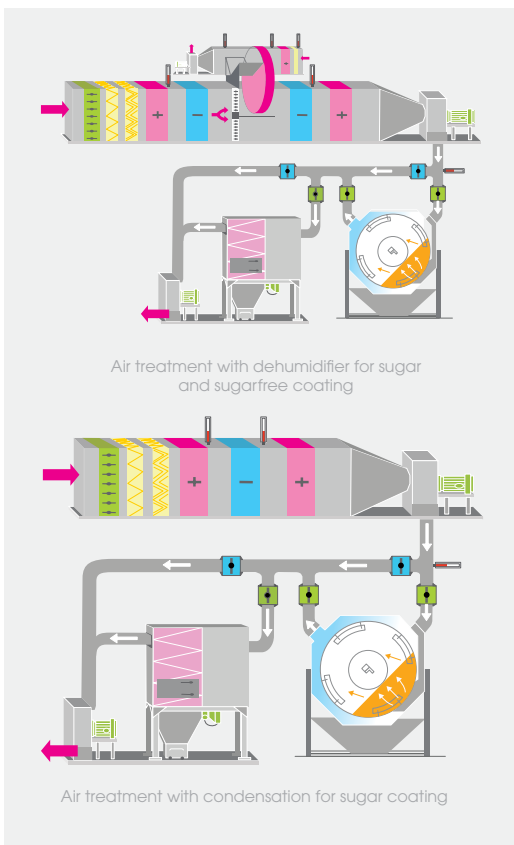

LOADING SYSTEM

Custom design solutions

- According to products fragility
- Adapted to batch size and facility layout
- Wide range of dosing conveyors, elevators, belts

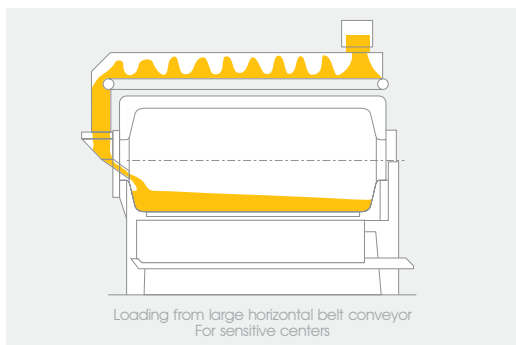
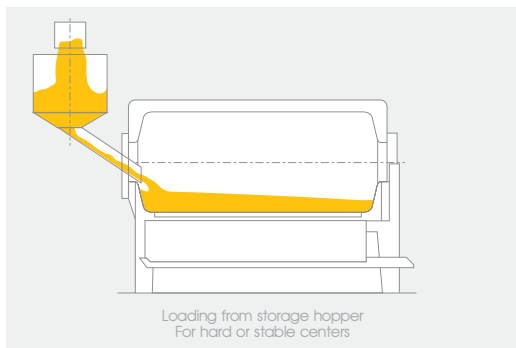

- Automatic fast loading system



UNLOADING SYSTEM

Fast unloading system by traps allowing to start next batch very quickly

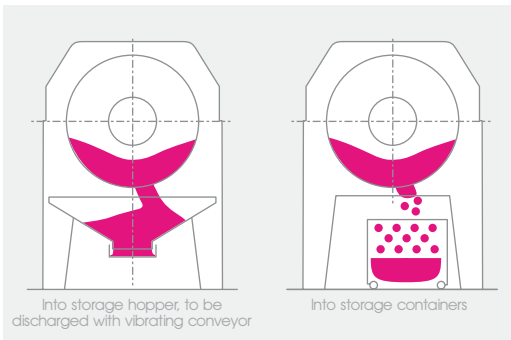

DEVELOPMENT AND ASSISTANCE

Industrial scale laboratory

Equipped with 250kg and 500kg coating machines
Recipe development with your products

On-site assistance

Operators and maintenance staff training
Process development and improvement



AUTOMATION

Effective control of the coating process with different possibilities

IDA PROG3

The basic solution for quality coatings with simple machine handling

- Automatic coating cycle according to programmed recipes.
- Semi automatic controls for loading, unloading and washing functions.

IDA PROG4

Fully automated system allowing to customize all machine parameters

- Automatic coating cycle according to user-friendly recipe building module
- All functions run from operator terminal including programmable sequences
- Overview screens for installation status
- Possibility to network with other machines and supervision system

IDA PROG5

The ultimate process, production and quality control. Supervisory Control and Data Acquisition (SCADA)

- Batch data recording and displaying
- Historical trends and fault reports
- Recipes download to IDA coaters
- Real-time overview of networked coaters

Dumoulin

Z.I. Le Closeau
5, rue Auguste Perdonnet
77220 Tournan-en-brie - FRANCE
Tél. : +33-(0)1 64 84 50 00
FAX : +33-(0)1 64 84 50 01

www.dumoulin.fr
E-mail : info@dumoulin.fr
RCS MELUN 582 045 852