

Easy Line Little,
semiautomatic corker
for natural corks
and synthetics

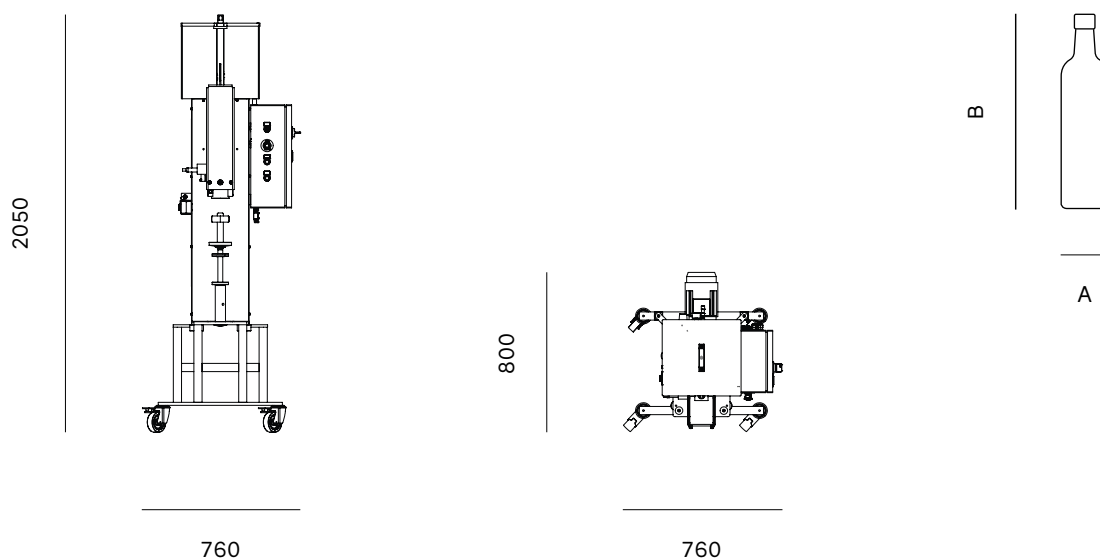

Realised to satisfy the demand of a small production. The corking unit does not need lubrication as the contact parts are made of self lubricating material and works therefore "dry". The absence of lubrication by means of grease or oil eliminates the related contamination. The cork jaws, which are made of polymers, guarantee a better sliding and absence of oxidation. Easy Line Little is designed to ensure a good result with its basic functions included in the model. In addition it can be enriched with a plus function.



● **FUNCTIONS**

- NATURAL CORKING EASY LITTLE

The corks are stacked by an automatic hopper feeding system.
The corker is equipped with corking system under vacuum.

● ● **PLUS FUNCTIONS**

- GAS INJECTION SYSTEM

This system allows inert gas injection into the bottle, which helps eliminate as much oxygen as possible.

Technical specifications

Machine weight	Approx. 132 Kg.	
Size	Approx. cm. 760x800x2050 H	
Consumption	Electricity 230V 50Hz 1.3 kW; Maximum absorption 6A - Air 150 l/min	
Productivity (*)	Up to 600 b/h	
Bottle size	A - Max 100 B - Min 230 Max 400	
Cap types and measures	Natural corks and synthetics	Diameter - Min 22 Max 27 mm - Height - Min 35 Max 50 mm