

kassow robots

strong · fast · simple

Cobots with 7 axes – shaping the future of flexible automation



strong

fast

simple

www.kassowrobots.com

How can you outsmart the competition?

Simply automate!

A payload of 5 to 18 kg and a reach of 850 to 1800 mm – all delivered at joint speeds of up to 225 degrees per second: Our five lightweight 7-axis robots are ready to go to work in virtually no time – at companies of all sizes.

Our concept of simply automate comes from our unique benefits:

- Plug-in configuration
- Intuitive programming with a phone-like user interface
- Easy relocation within a factory thanks to the lightweight design
- And, above all, higher production

Your robot colleague will take over the repetitive and physically demanding jobs in your factory so workers can then perform jobs that generate more value.

Your major benefit: Every cobot made by Kassow Robots has a 7th axis. This axis gives our cobots the highest possible degree of freedom. The robot's arm mimics the dexterity of the human arm. A feature that enables it to reach around corners.

From standard to sophisticated tasks, our cobots are prepared to perform the infinite number of jobs required in factory automation operations (see page 4).



- 7 axes
- Lightweight robots
- Payloads of up to 18 kg
- Reach of up to 1800 mm
- Speeds of up to 225 degrees per second
- Perfect for human-robot collaboration (HRC)

Kassow Robots: Product Family

| | Reach/Payload |
|---------------|---------------|
| KR810 | 850 mm/10 kg |
| KR1018 | 1000 mm/18 kg |
| KR1205 | 1200 mm/5 kg |
| KR1410 | 1400 mm/10 kg |
| KR1805 | 1800 mm/5 kg |



KR1410

KR1805

Great potential for beginners and pros



- Providing you with our modular platform CBuns for capability extensions
- Seamless end-of-arm tooling that is easy to install and configure
- Option to extend any kind of software based on efficient C/C++ code using robot API
- Option to prepare and import your own custom code into our system
- 500Hz servo loop
- ROS integration

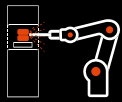

WELDING



PACKAGING & PALLETIZING

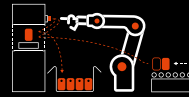

CNC & MACHINE TENDING



PICK & PLACE

Cobots with maximum dexterity in action

Pick & place, machine tending, welding, gluing, labelling, palletizing: From small batch to 24/7 mass production, our lightweight robots can perform virtually any production task.

The special kinetics created by the 7th axis allows Kassow Robots to outclass conventional cobots.

Kinematic examples:

- Any predefined path – straight, zigzag, or curved – can be followed without stopping and at a pre-set speed.
- The extraordinary maneuverability allows the cobots to be used in the most confined spaces – an invaluable benefit in the push to automate existing production.



CNC



Dispensing



Labelling



Laser Engraving



Welding



Assembling

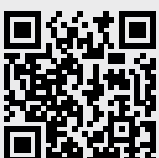

www.kassowrobots.com/cases

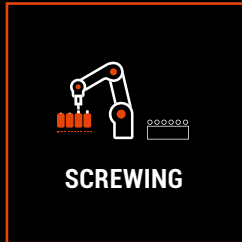

Gaining far more production with 7 axes

Your added value created by our lightweight robots

- **Great maneuverability & around-the-corner reach**
You can use the robot's arms in extremely confined spaces – and profit from the tremendous flexibility created by the 7th axis!
- **Easy programming & operations**
Divorce yourself from robot experts – program and operate the cobots yourself!
- **High flexibility & fast relocation**
Use the cobots in different places within your production facilities – the cobots' light weight and the plug and play approach makes it possible!
- **Employees & cobots team up**
Delegate the repetitive and unsafe jobs to your robot colleagues – and allow your employees to generate more added value elsewhere!
- **Fast ROI & more satisfied employees**
Our cobots pay for themselves quickly – boost your competitiveness with their high productivity!



"Strong, Fast, Simple" and lots of added value created by the 7th axis – company founder Kristian Kassow continues to look out for the customers.



Sales Director Dieter Pletscher shows just how easy it is to operate a cobot. "It reminds me of a smartphone."

Robots that can share work space with humans without being placed in safety enclosures are called collaborative robots or simply "cobots." In the process known as human-robot collaboration (HRC), a robot's various skills (e.g., strength, precision, and stamina) are combined with the strengths of humans (e.g., make decisions, evaluate alternatives). As a result, robots and humans can work near one another. The entire process is safe: if, for instance, a cobot encounters a barrier, it will shut off automatically.

Dimensions and special product features

Robot head & ports

All cobot models

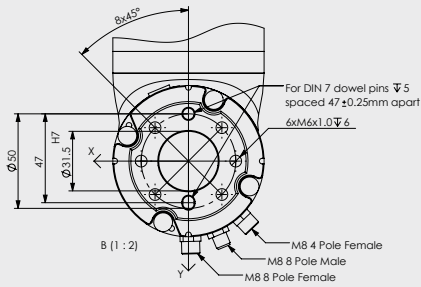

Dimensions of the base plate

KR810, KR1205

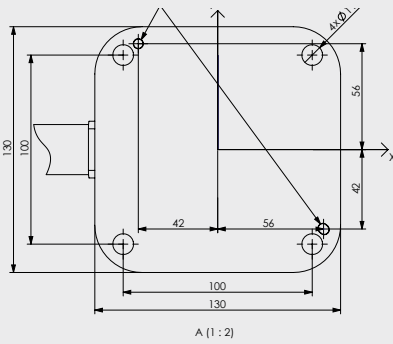

KR1018, KR1410, KR1805

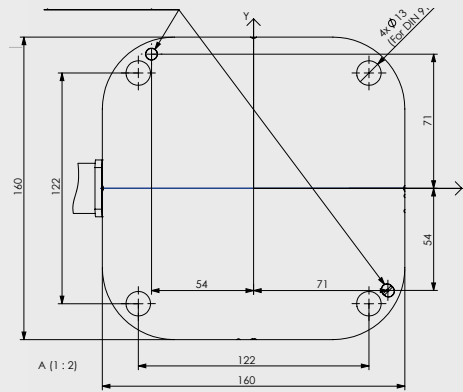

Connectivity

- Three I/O ports with 24V power
- Ethernet port (ModBus TCP)

Our cobots can be connected directly to end-of-arm tool.



Free drive button

- Flexible waypoint programming
- Operation without a user panel



Are you interested in flexible automation?

Contact us if you have any questions about our cobots or have specific projects in mind!

At a glance: Technical specifications

| General specifications | KR810 | KR1018 | KR1205 | KR1410 | KR1805 |
|-----------------------------|---|-----------|-----------|-----------|-----------|
| Reach (mm) | 850 | 1000 | 1200 | 1400 | 1800 |
| Payload (kg) | 10 | 18 | 5 | 10 | 5 |
| Weight (kg) | 24 | 34 | 25 | 35 | 38 |
| Joint speed (deg/s) | 225 | 163/225 | 225 | 163/225 | 163/225 |
| Joint ranges (deg) | J2 and J4: -70°/+180°; J1, J3, J5, J6 and J7: ±360° | | | | |
| Brakes on joints | Yes | Yes | Yes | Yes | Yes |
| Absolute encoders on joints | Yes | Yes | Yes | Yes | Yes |
| Repeatability (mm) | +/- 0.1 | +/- 0.1 | +/- 0.1 | +/- 0.1 | +/- 0.1 |
| Degrees of freedom | 7 | 7 | 7 | 7 | 7 |
| Footprint (mm) | 130 × 130 | 160 × 160 | 130 × 130 | 160 × 160 | 160 × 160 |
| Operating temperature (C°) | 0–45 | 0–45 | 0–45 | 0–45 | 0–45 |
| Body material | Anodized aluminum | | | | |
| Protection rating | IP54 | IP54 | IP54 | IP54 | IP54 |

| Controller | KR810 | KR1018 | KR1205 | KR1410 | KR1805 |
|----------------------------|-------|--------|--------|--------|--------|
| Digital outputs 24V (pcs) | 8 | 8 | 8 | 8 | 8 |
| Relay outputs (pcs) | 4 | 4 | 4 | 4 | 4 |
| Digital inputs 3–30V (pcs) | 16 | 16 | 16 | 16 | 16 |
| Analogue I/O 0–10V (pcs) | 2/2 | 2/2 | 2/2 | 2/2 | 2/2 |
| Analogue I/O 4–20mA (pcs) | 2/2 | 2/2 | 2/2 | 2/2 | 2/2 |

| Power | KR810 | KR1018 | KR1205 | KR1410 | KR1805 |
|---------------------------------------|--------------------|--------------------|--------------------|--------------------|--------------------|
| Power consumption (with max. load; W) | 400–600 | 400–1200 | 400–600 | 400–1200 | 400–1200 |
| Supply voltage (VAC) | 100–120 or 200–240 | 100–120 or 200–240 | 100–120 or 200–240 | 100–120 or 200–240 | 100–120 or 200–240 |
| Supply current (A) | 16 | 16 | 16 | 16 | 16 |
| Supply frequency (Hz) | 50/60 | 50/60 | 50/60 | 50/60 | 50/60 |
| Max speed (mm/s) | 1200/1800 | 2000/2400 | 1200/1800 | 2000/2400 | 2000/2400 |
| Sound level (dB) | <65 | <65 | <65 | <65 | <65 |

7 Axes • Collaborative • Strong • Fast • Simple • Flexible • Danish

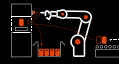

About Kassow Robots

"Strong, Fast, Simple": With this motto in mind, the Danish entrepreneur Kristian Kassow has developed five unique, efficient, lightweight robots with 7 axes. Manufactured in Copenhagen, KR cobots are extremely strong and fast, despite their long reach. They offer a payload of up to 18 kilograms, a reach of up to 1800 millimeters, and a speed of up to 225 degrees per second. Their exceptional maneuverability enables industrial companies to automate production processes even in

the most confined areas. The cobots are operated and programmed with the help of teach pendants developed on the basis of widely used tablet technologies. It is an intuitive process and can be done by anyone – a feature that creates more independence and cost efficiency.

Boost your competitiveness and let our cobots take care of the automation for you and benefit from increased autonomy and cost efficiency.

Extensive Partner Network – reliable partners

Did you know that Kassow Robots has developed an extensive network of business partners across four continents and 30 countries and is continuously expanding its network?

Our partners are from medium-sized enterprises, speak the language of our end customers, and are available to assist them even after the purchase of the 7-axis cobots.

The Kassow Robots partner network and we look forward to your request:

www.kassowrobots.com/partner



Kassow Robots Aps
Oliefabriksvej 57
2770 Kastrup/Copenhagen
DENMARK
+45 20 24 09 95
sales@kassowrobots.com
www.kassowrobots.com

www.linkedin.com/company/kassow-robots-aps/



Your Local Kassow Robots Partner

MECMATICA SRL
Via Campo Romano, 13 24050 Spirano
(BG)
ITALIA
+035 320144
automation@mecmatica-automation.it
www.mecmatica-automation.it

7 Axes • Collaborative • Strong • Fast • Simple • Flexible • Danish