

Square Slim Canopy Light

3-Power + 3 CCT Selectable



EnVisionLED's innovative Square Slim Canopy Light provides bright, even illumination for applications where high efficacy is desired. Offering a universal mounting bracket for ease of installation means less labor costs and with our **Select-N-Switch technology**, your choice of wattage and color temperature can be chosen at the time of installation. This Square Canopy provides unique reverse-throw lighting which gives up light, avoiding the common cave effect with other products on the market.

Applications:

- Parking Structures
- Canopies
- Car Parks
- Soffits
- Outdoor Corridors

Product Information:

- 3CCT Selectable: 30/40/50K
- Optional Bi-Level Motion + Daylight Sensor Available
- Optional Emergency Backup Available
- Di-Cast aluminum housing with PC lens
- No UV emission, no flicker, instant start, no humming
- L70 @ 50,000 hours lumen maintenance

Detail Specifications:

- IP65 Wet Location Rated
- CRI 80 SMD Lumiled LED Chips
- 100-277V Driver
- 150° Beam Angle/Type VS Distribution
- Operating Temperature: -4°F ~ +124°F
- Storing Temperature: -40°F ~ +185°F
- PF >0.9/Input: .85A/Output: 36-66V DC
- 0-10V Dimmable

Certifications:

- cUL Listed
- DLC Listed
- FCC CFR 47, FCC Part 15, Subpart B:2017
- 5 Year EnVision LED Limited Warranty

L
E
D
-
S
C
P
-
Wattage
-
T
R
I
-
Finish
-
Accessories
-
EMB
-
Warranty

1 Product	2 Wattage	3 Color	4 Finish	5 Accessories	6 EMB	7 Warranty
LED-SCP	3P60 25W 3,625lm 40W 5,800lm 60W 8,700lm	TRI 30/40/50K Selectable	WH White BZ Bronze	(Blank) None HB02DMS Daylight Sensor/ Bi-Level Motion Sensor Controller for HB02R (Controls Multiple) SBT Bluetooth Control BMS Bi-Level Motion Sensor HV 347-480V Driver for Fixture	(Blank) None EMB 20W Internal Emergency Backup	(Blank) 5 Year (incl.) 10YR 10 Year

Specs and model numbers are subject to change with or without notice

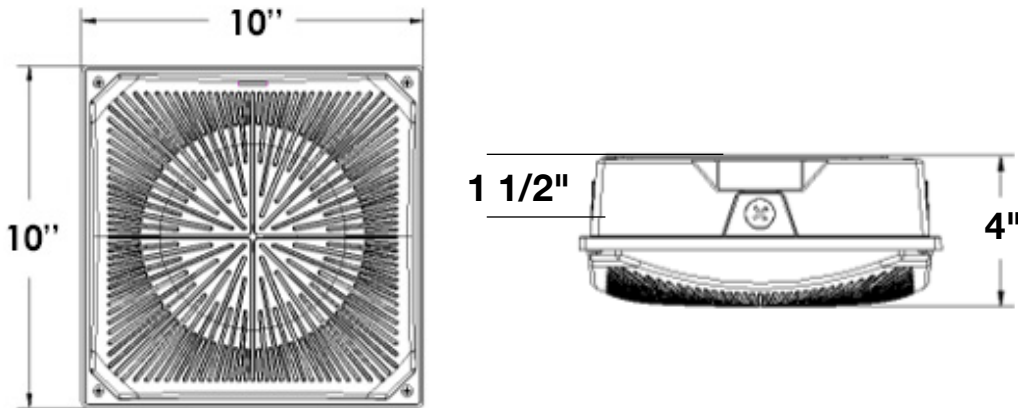
DIMENSIONS**Mounting:**

- Easy surface mount installation with universal mounting plate
- Easy 1/2" pendant mount/stem installation
- Pre-wired circuit wiring built in (3 in / 3 out)
- 1/2" Knockouts located on 4 sides and on top of the housing

FEATURES**Rugged Aluminum Housing**

Robust die-cast aluminum housing includes corrosion resistant primer and powder coat finish

3CCT Selectable

Selectable colors
30/40/50K

**Integrated Heatsink**

Improves longevity of fixture by dissipating heat generated during operation

3-Power

Selectable wattages:
25/40/60W (145lm/w)

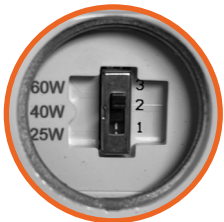
**Reverse-Throw Light**

Light is emitted from the back of the fixture as well as the front

Instant Start

.No flickering or humming
Light is soft and uniform while being easy on the eyes

Optic Lens

Each chip is controlled in order to provide forward throw light output