

9" Round Slim Emergency Battery Backup

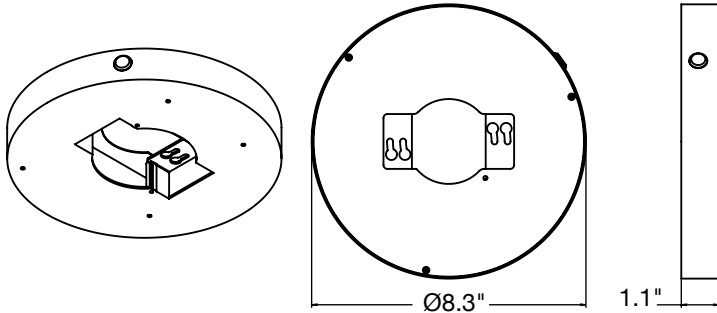

TOOLS & MATERIALS REQUIRED



*Wiring supplies are required by the Canadian Electrical Code and/or the Quebec electrical code.

SAFETY RECOMMENDATIONS

1. The lighting shall be mounted at a height of maximum 4.0m
2. Do not use outdoors
3. Do not mount near gas or electric heaters. Do not let power supply cords touch hot surfaces.
4. Use caution when changing batteries - **TURN ALL POWER OFF, BOTH WALL SWITCH AND MAIN POWER!** Use only designated battery as supplied with original unit or as listed for use with this product. Dispose of old battery in designated disposal location.
5. Equipment should be mounted in locations and at heights where it will not be subject to tampering by unauthorized personnel.
6. This product is designed for use with the 9" round series lighting. Must be used with any other fixture.
7. Do not use this product for other than intended use.

All serving should be performed by professional personnel.
SAVE THESE INSTRUCTIONS.

TEST BUTTON AND LED INDICATOR

TEST BUTTON FUNCTIONS

1. WHILE MAIN POWER IS ON

A quick press of the test button, (<3 seconds), simulates the "main power outage" or "emergency mode"
 The light fixture will come on in this case-it will be running on battery power.
 Pressing test button for 3-6 seconds puts the unit into the monthly self-check routine (approx. 3 minutes run time).
 Press test button again anytime to stop the routine.
 As the system runs its check on the battery power and circuit connections, the LED indicator will flash green at 1 cycle/second.
 Pressing test button for >6 seconds puts the unit into the annual self-check routine. Up to 90 minute run time
NOTE: THIS SYSTEM WILL COMPLETELY DISCHARGE THE BATTERY DURING THIS ROUTINE.
 Press test button again anytime to stop the routine.
 As the system runs its more detailed annual check on the battery power and circuit connections, the LED indicator will quickly flash green at 3 cycle/second.

2. EMERGENCY STATUS (MAIN POWER OUTAGE)

Pressing test button for <1 second shuts off the unit, press again to turn back on.
 Pressing test button for >6 seconds completely shuts off emergency output. In this state, the system will not function unless the main power is restarted.

LED INDICATOR COLORS/FUNCTIONS

- RED:** Battery is charging
- GREEN:** Battery is fully charged
- YELLOW:** Check system - possible battery replacement needed or system maintenance required
- GREEN FLASHING:** Monthly annual check mode is running.
- OFF:** Indicates a power outage, when the battery backup unit is in emergency mode the LED indicator will be OFF.
- MINIMUM CHARGE TIME:** 24 hours.

OPTION #1: SLIM SURFACE MOUNT

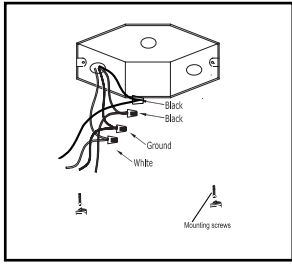

1. Turn OFF/disconnect power at circuit breaker. Typical junction box wiring has only white and black switched wires controlled by wall switch for ON/OFF or dimming. Ensure the junction box has an additional set of unswitched wires (continuous) main power wires as shown.

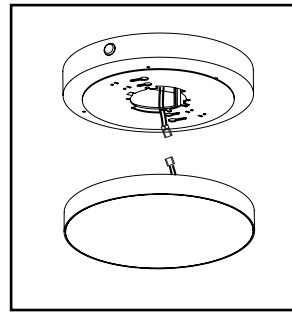

3. Make electrical connections from the blink LED lighting fixture with the battery backup.

- Use the orange connector already supplied and affixed to the unit.
- Be sure to connect the ground wire coming from the lighting fixture.

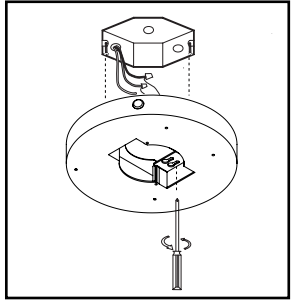

2. Screw the emergency backup unit up into the junction box using the screws provided. Then using the wire unit provided, connect the three cables available for connection into the junction box.

- Connect the "switched line" to the black switched power cable coming from the junction box.
- Connect the "continuous main power" from the battery backup box to the continuous main black wire from the junction box.
- Connect the "neutral" white wire from the battery backup together with the other two neutral wires coming.

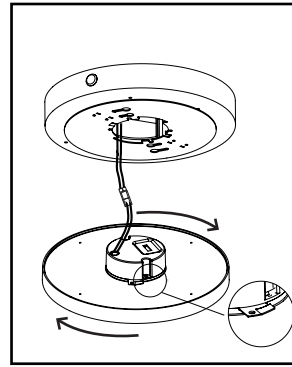

4. Pop and lock into place.

- Feed all wires up into the battery backup box.
- Complete installation by pushing the fixture into the mounting plate.

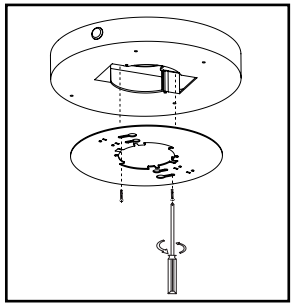

FOR CONTINUOUS POWER APPLICATIONS

If the battery back up is used for:

- A system with 24/7 lighting
- As a dedicated emergency lighting only, (light off in normal condition) Only continuous unswitched power is needed at the junction box-no need for switched wires.

OPTION 1

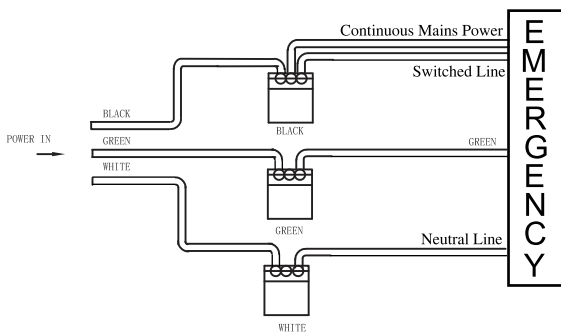

For option 1, above as 24/7 lighting:

- Connect the two black wires (labeled as "continuous main power" and "switched line") from the battery backup to the black main wire in the junction box and connect the white ("neutral") to white from the box wires.
- Screw the 2x 8/32 screws provided then go to STEP 4 (shown above)

OPTION 2

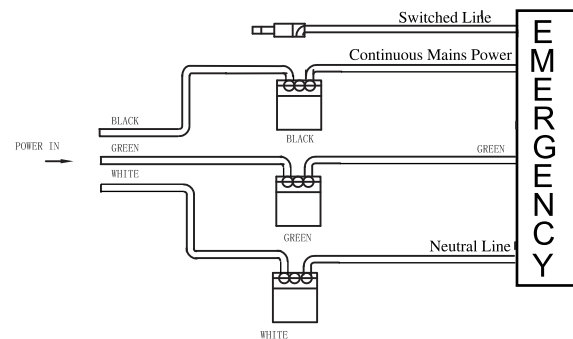

For option 2, above as emergency light only:

- Connect the black wire (labeled as "continuous main power") from the battery backup to the black main wire in the junction box and connect white ("neutral") to white from the battery backup fixture to the junction box.
- Screw wire nut over the "switched line" and leave unconnected. Then screw the emergency backup unit up into the junction box using 2x 8/32 screws provided, then go to STEP 4 (shown above).