

Undercabinet Puck Light Installation Instructions

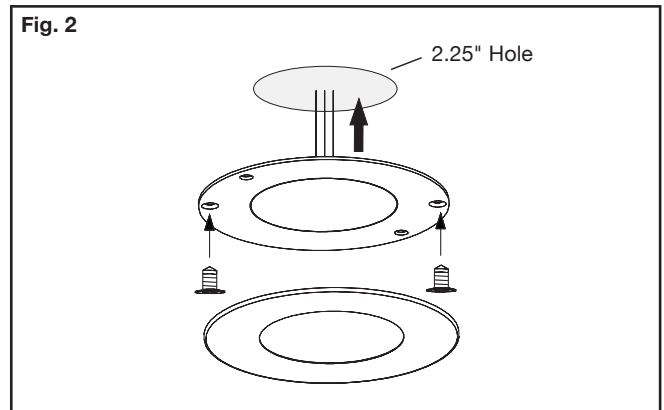
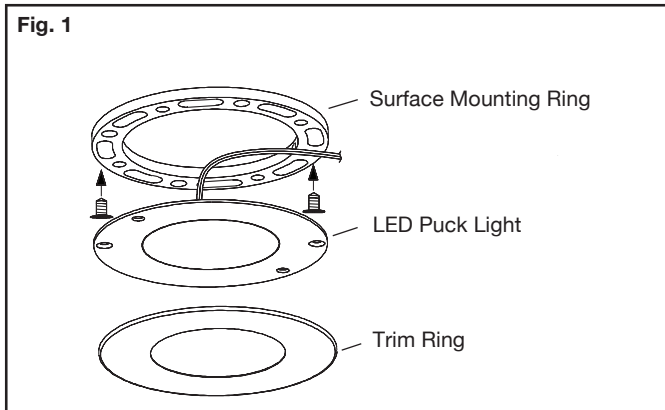

IMPORTANT: Read all instructions before installing fixtures.

Retain for future reference.

- To be used only with listed class 2 power supplies.
- Always consider voltage drop effect when linking fixtures together.
- To extend driver life span, do not exceed 80% of driver rated load.

SAFETY: For your safety, this fixture must be wired in accordance to local electrical codes and ordinances. All work should be done by a qualified electrician.

WARNING: Make certain power is OFF from the electrical panel before starting installation or attempting any maintenance. Indoor installation only.

1-PACK INCLUDED COMPONENTS:

- 1 x LED puck light
- Surface mounting ring
- Trim ring
- Mounting hardware

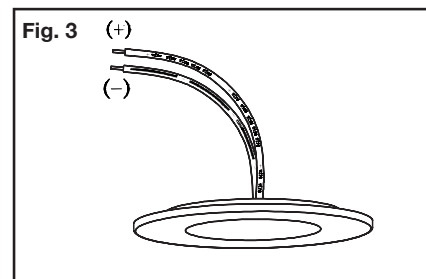

3-PACK INCLUDED COMPONENTS:

- 3 x LED puck light
- Surface mounting ring
- Trim ring
- 12W LED Driver, constant voltage, 12V, Class I
- Mounting hardware

TOOLS REQUIRED:

- Power Drill
- Screw Driver
- For Round: 2-1/4" Cut hole saw (Recess mounting without torsion clips)
- For Square: 2-1/4" x 2-1/4" Cut hole saw (Recess mounting without torsion clips)

ASSEMBLY INSTRUCTIONS:

1. Open packaging and place all components onto a clean surface.
2. Turn power OFF from the electrical panel before starting installation.
3. A) For surface mounting: Remove the trim ring from the puck light and lift the LED light out of the surface mounting ring (without completely removing wire). Position mounting ring into the desired location. Ensure the wire for the LED puck light is positioned in the wire groove of surface mounting ring. Attach surface mounting ring to medium using the screws provided [Fig.1]. Pull the excess wire through the wire notch then re-attach the LED light to the surface mounting ring. Connect the trim ring to the LED puck light magnet tabs. Attach wire evenly to surface medium with mounting hardware.
 B) For recessed mounting: Remove the trim ring from the puck light and remove the LED light completely from surface mounting ring. With a screw driver (supplied by others) detach the torsion clips from the LED puck light. In your desired area drill a 2-1/4" hole, using a cut hole saw (supplied by others). Run the wires through the cut hole, and then secure the LED puck light to medium with screws provided [Fig.2B]. Connect the trim ring back to the LED puck light magnetic tabs.

4. A) For Hardwire: Use wire type and gauge suitable for application to connect the fixtures, and twist-on wire connectors (supplied by others) [Fig.4A]. Ensure correct polarity is followed through the line [Fig.3].
 B) For Plug-in: Make a daisy chain connection with male to female DC connection. Attach female DC connector to a power feed from the 12V constant voltage driver [Fig. 4B].
5. Rest driver to the desired secured location.
6. Once assembly is complete, turn on power to confirm fixture is working properly.

