



S-Line: Bi Level Motion Sensor 1/2" Knockout



TECHNICAL DATA

POWER SUPPLY	12V-24V DC
HF SYSTEM	5.8GHz±75MHz
DIM CONTROL OUTPUT	0-10V Max. 25mA Sinking Current
DETECTION RADIUS/ANGLE	Max. 26ft. / 360°
MOUNTING HEIGHT	Max. 40ft.
REMOTE RANGE	50ft. Indoor, No Backlight
HUMIDITY	Max. 95% RH
TEMPERATURE	-40°F ~ 158°F

NOTE: The high-frequency output of this sensor is <0.2mW that is just one 5000th of the transmission power of a mobile phone or the output of a microwave oven.

Series
S-BMS-EXT-1

Specs and model numbers are subject to change with or without notice.

INSTALLATION

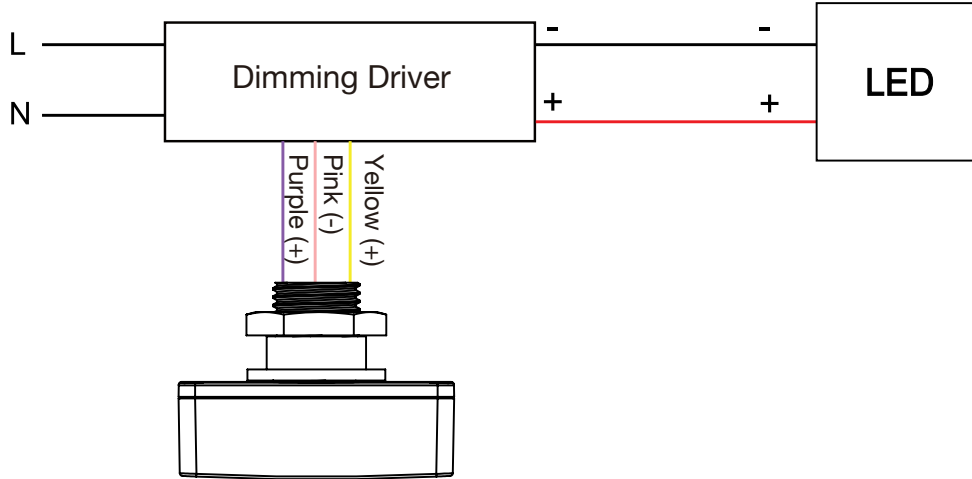

DIMENSIONS

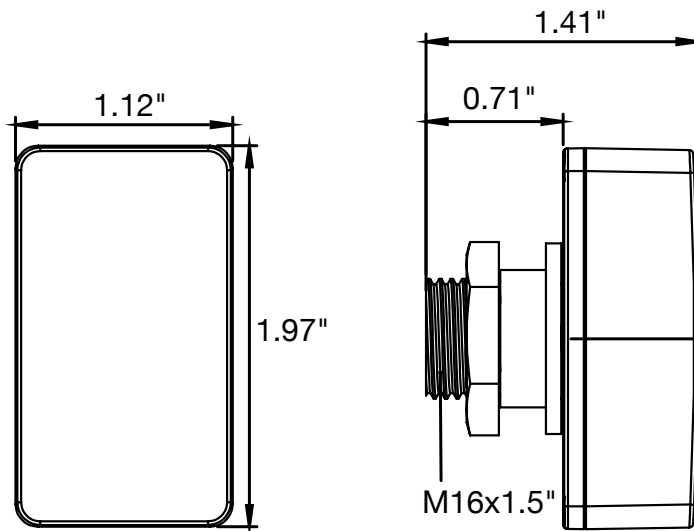

PERFORMANCE

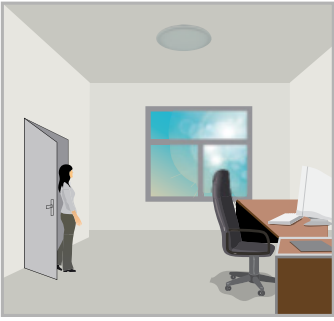

With sufficient natural light, the light does not switch on when presence detected.



With insufficient natural light, the sensor switches on the light automatically when person enters the (options) standby level after the room. The lamp never switch off with presence, even the nature light is sufficient.



People left, light still dims to 0/10%/30%/50% (options) standby level after the hold time.



Light switches off automatically after the dimming time elapsed.

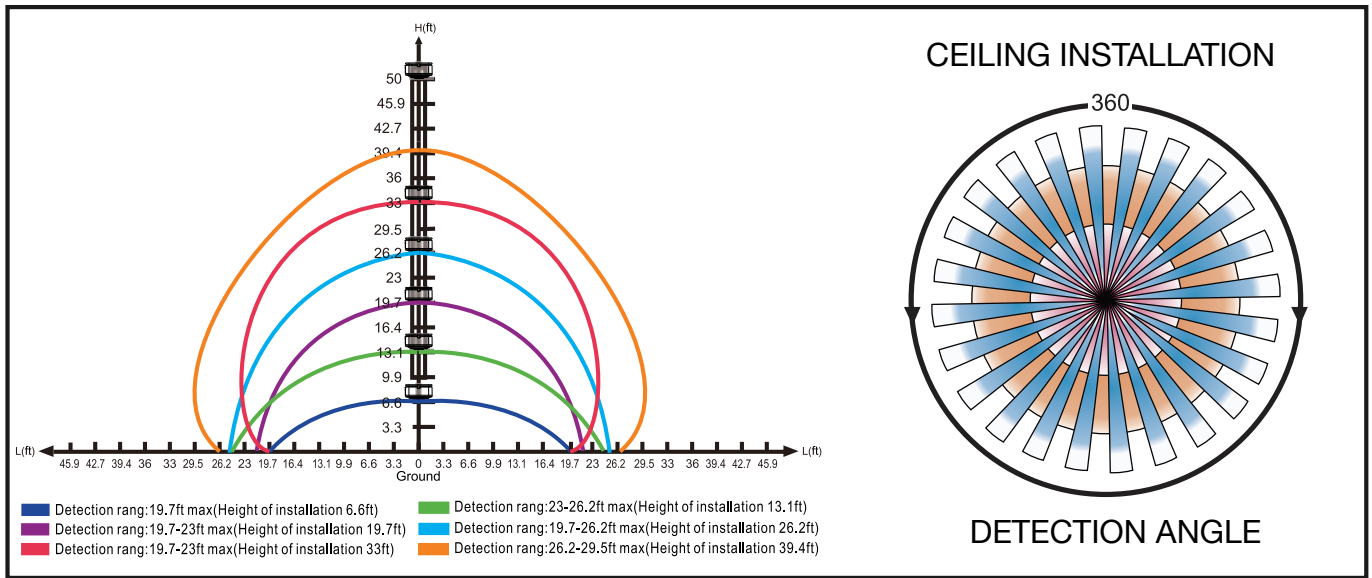

SENSOR COVERAGE















Once powering the device up, the ANT-11 will use factory default parameters to operate. If adjustments are needed, "RC-100" Wireless IR configuration tool must be used,

REMOTE CONTROL



LED	DESCRIPTION
BRIGHTNESS	High end trim turning function (to set the putput level of connected lighting during occupancy).
SENSITIVITY	To set the occupancy sensitivity of the sensor.
HOLD TIME	The time the sensor will turn OFF (if you choose stand-by level is 0) or dim the light to a low level after the area is vacated.
DAYLIGHT SENSOR	Represents various thresholds of natural light level for the sensor.
	To select the current surrounding lux value as the daylight threshold. This feature enables the fixture to function well in any real application circumstances.
	The daylight sensor stops working and all motion detected could turn on the lighting fixture, no matter how bright the natural light is.
STAND-BY DIM	To set the output level of connected lighting during vacancy. The sensor will regulate the lighting output at the set level. Setting the STAND-BY DIM level at 0 means light full off during vacancy.
STAND-BY TIME	Represents the time at the sensor will keep the light at low dim level after the HOLD-TIME elapsed.

BUTTON	DESCRIPTION
	Press the ON/OFF button, the light goes to permanent ON or permanent OFF mode and the sensor is disabled. (MUST press the ON/OFF button to stop this mode for setting.
	Press AUTO button, the sensor starts to function and all settings remain the same as the latest status before the light is switched ON/OFF
	Display the current/latest setting parameters in LED indicators (the LED indicators will be ON for showing the setting parameters).
	Press the RESET button, all settings go back to the settings of dip switch in sensor.
	The button TEST2s is for testing purpose sensitivity only. After you choose sensitivity thresholds, then you press TEST2s button. The sensor goes to test mode (hold time is 2s) automatically, meanwhile the stand-by period and daylight sensor are disabled. Press AUTO button to quit from this mode.
	Enter in the setting condition, the parameter of remote control will flash to be selected and navigate to UP and DOWN to choose selected parameters in LED indicators.
	Navigate LEFT and RIGHT for chosen selected parameters in LED indicators.
	Confirm the selected parameter in the remote control.
	Press SEND button, upload the current parameters to sensor(s) the LED light which the sensor connects will ON/OFF as confirmed.
	Open and close smart daylight sensor. Press UP button or DOWN button. Enter in the setting condition, the parameter leds of remote control will flash to be selected. Press  for open or close smart daylight sensor.
	4 scene modes with preset parameters which are available to be changed and saved in modes.

Series
S-LINE-R
1W • 12V