

Snap On Sensor x EnVisionLS Enabled

Bi-Level Motion + Daylight Sensor



S-SN-PIR-SL allows for individual luminaire control and is equipped with both occupancy + daylight sensing. It utilizes a Bluetooth® Low Energy (BLE) mesh network. Commissioning can be set through the ENVISIONLS mobile app.

Detail Specifications:

- Input Voltage: 10-14V DC | 50mA
- Operating Temperature: -4-104F°
- Finish: White
- 360° detection
- Max Bluetooth Range: 328' line of sight
 - Highly dependent on surrounding environment
 - Bluetooth test recommended for range accuracy
- IP Rating: IP20 Damp Location

Applications:

- Commercial & Industrial
- Troffers, Wraps, Strips, & Other Linear Fixtures

Product Information:

- PIR motion sensor: Ideal for indoor environments with clear lines of sight to the area of interest. Detects warm objects, good for high vibration, areas of metal.
- Daylight Sensor: controls power consumption of the fixtures based on sunlight levels
- Magnetic Reset: touch the top part of the sensor for 5 seconds
- Include parameter profiles, dimming control, real-time sensor feedback
 - View our ENVISIONLS guide for full features

Mounting & Installation:

- Snap-On: sensor will be pre-fabricated at the factory level onto our various fixtures
- Max Mounting Height: 12ft

Certifications:

- UL Listed for USA and CA
- DLC NLC Listed ID NSLVR23CNTRL
- Bluetooth
- Approved for CA T24
- 5 Year Limited Warranty
- FCC CFR 47, GCC Part 15, Subpart B:2017

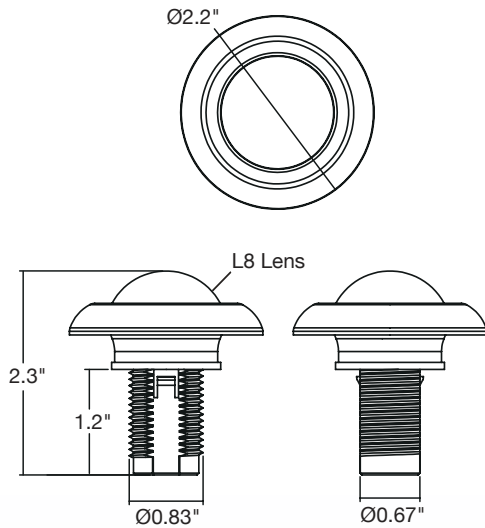

Item
S-SN-PIR-BT