

PL LAMP: G24
Fluorescent Replacement
4-CCT + 4-Power Selectable



EnVision LED has manufactured a G24 PL lamp replacement in LED that can work with or without the existing ballast. With a 360° angle, replace existing fluorescent G24 lamps in either vertical or horizontal direction. Unlike fluorescents, our LED lamp does not need time to warm up, it turns on instantly.

Detail Specifications

- IP Rating: Damp Location
- Beam Angle:
 - Directional: 110°
 - Omni-Directional: 360°
- 4-CCT: 30/35/40/50k
- 5-Power: 15/12/10/8w
- Chip: SMD 2835, R9 >50, CRI >80
- Operating Temperature: -4° - 114° F
- Average life (L70) of 50,000 hours

Applications:

- Can Lights
- Recessed Housings
- Interior Lighting
- Downlighting
- Showcases
- Residential, Commercial and Industrial

Product Information:

- Type A + B: Suitable for use in existing fixtures (view ballast compatible list) or ballast bypass
- Instant-On to full brightness
- Select-n-Switch Technology: 4-CCT & 4-Power Selectable

Driver Options:

- 120-277V
- Non-Dimmable
- PF >0.9, 50/60Hz

Mounting & Installation:

- G24Q-1, G24Q-2, G24Q-3, GX24Q-2, GX24Q-3
- Direct PL Lamp Replacement

Certifications:

- ETL Listed for USA and CA
- 5 Year Limited Warranty
- FCC CFR 47, GCC Part 15, Subpart B:2017

Compatible Ballast List

TRIAD
C2642UNVME
C2642/347ME
OSRAM SYLVANIA
QTP 2x26CF/UNV DM
QTP 2x26/32/42CF/UNV DM PEM
QTP 2x26/32/42CF/UNV DM
QTP 2x26CF/UNV DM
FULHAM
RHA-UNV-226-C
GE PROLINE
GEC226-MVPS-3W-L
HOWARD
EP2/26CF/MV/2
TOPAZ
B2642UNV/ME-TPZ
PROLUME
EP2CF26PS/MV/DC/K
KEYSTONE
KTEB-226-1-TP
KTEB-226-UV-RS-DW

WATT	LUMENS
8	960
10	1,200
12	1,440
15	1,800



4-Pin G24 Base

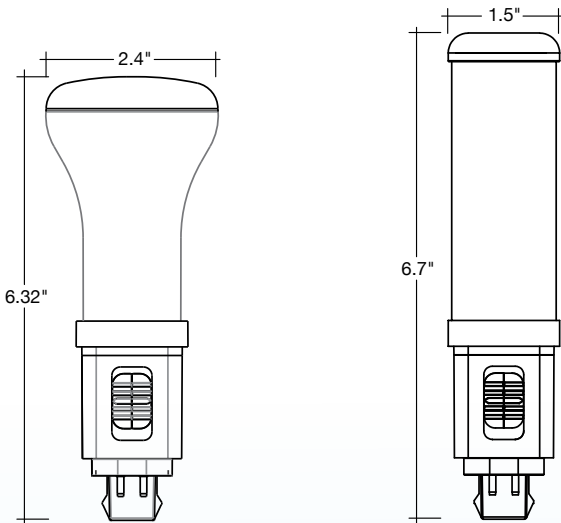

Series

LED-PL-G24-4P15-4CCT-DR
LED-PL-G24-4P15-4CCT-OMNI

Specs and model numbers are subject to change with or without notice.