

Battery Backup

16W-HV-0/10V



SPECIFICATIONS

RATED INPUT	100-277Vac, 50/60Hz, 5W max
INPUT CURRENT	80mA max
POWER FACTOR	>0.5
L IN TO L OUT	AC 3A max
BATTERY PACK VOLT/CAPACITY	Li-ion, 7.2V, 2.6Ah, 18.72Wh
OUTPUT VOLTAGE (EM MODE)	DC150-170V
OUTPUT POWER (EM MODE)	16W
STARTUP CAPABILITY/TIME	400W 500ms
RECHARGE TIME	≥36hours
TA	32°F<---->122°F
SUITABLE LAMP POWER	10-300W
LAMP POWER MUST BE WITH 0-10V or 1-10V DIMMER FUNCTION	≥32Watt
LAMP POWER WITHOUT 0-10V OR 1-10V DIMMING	≥31Watt

FEATURES

- UL Listed for damp locations.
- Suit for 10-300W lamp with 0-10V dimming function.
- Suit for 10-32W below lamp with or without 0-10V dimming function.
- DC120-190V Output.
- Initial functional self-check.
- Built-in high power AC relay to control normal led driver operation.
- Used with Lithium iron battery.
- Over-Charging/discharging protection.
- Rest mode.
- >90 minutes emergency time.
- ta: (32°F...122°F)
- Initial functional self-test
- IP20

Series

LED-EMB-16W-HV-0/10V

16W • Input: 120-277V AC 50/60Hz • Output: 120-190Vdc

Specs and model numbers are subject to change with or without notice.

FEATURES

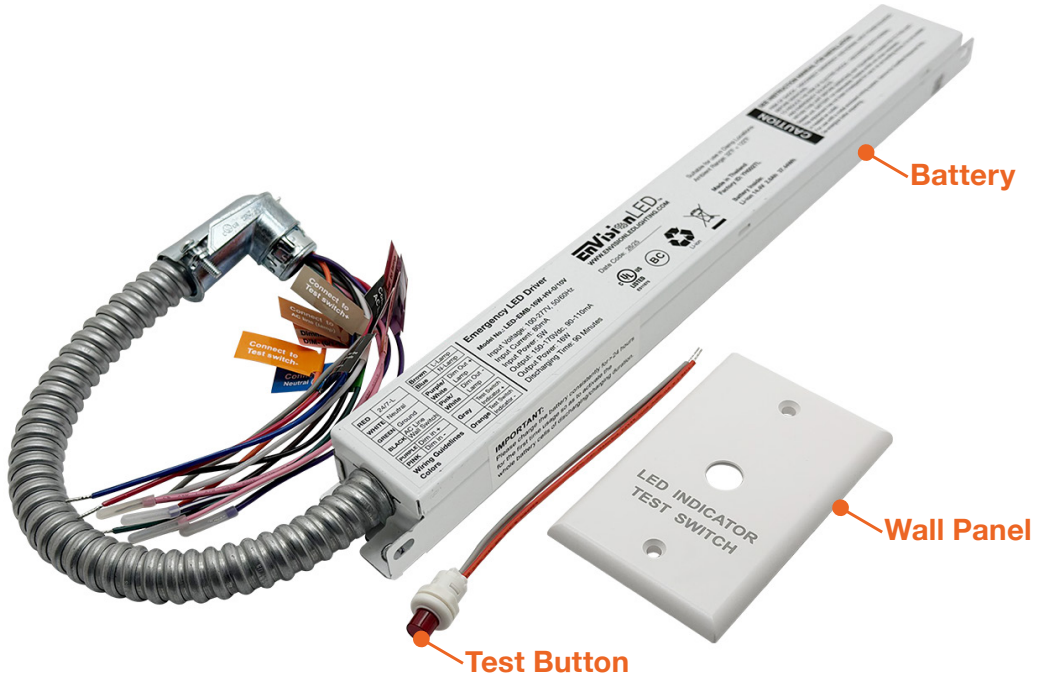

DIMENSIONS

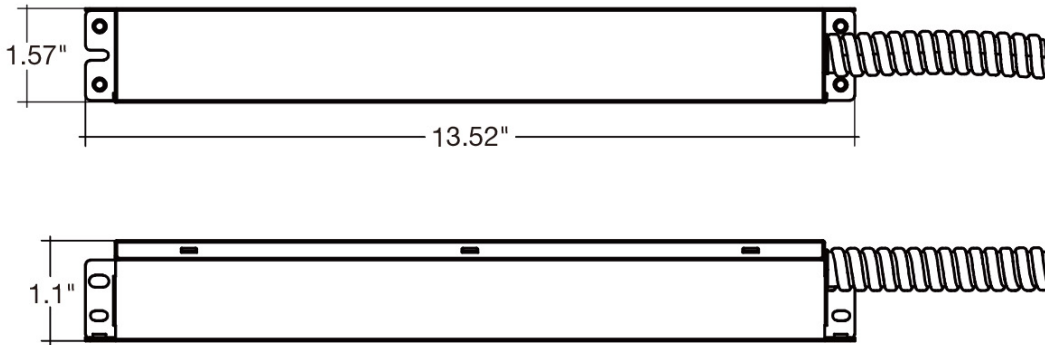

Specs and model numbers are subject to change with or without notice.

WIRING DIAGRAM

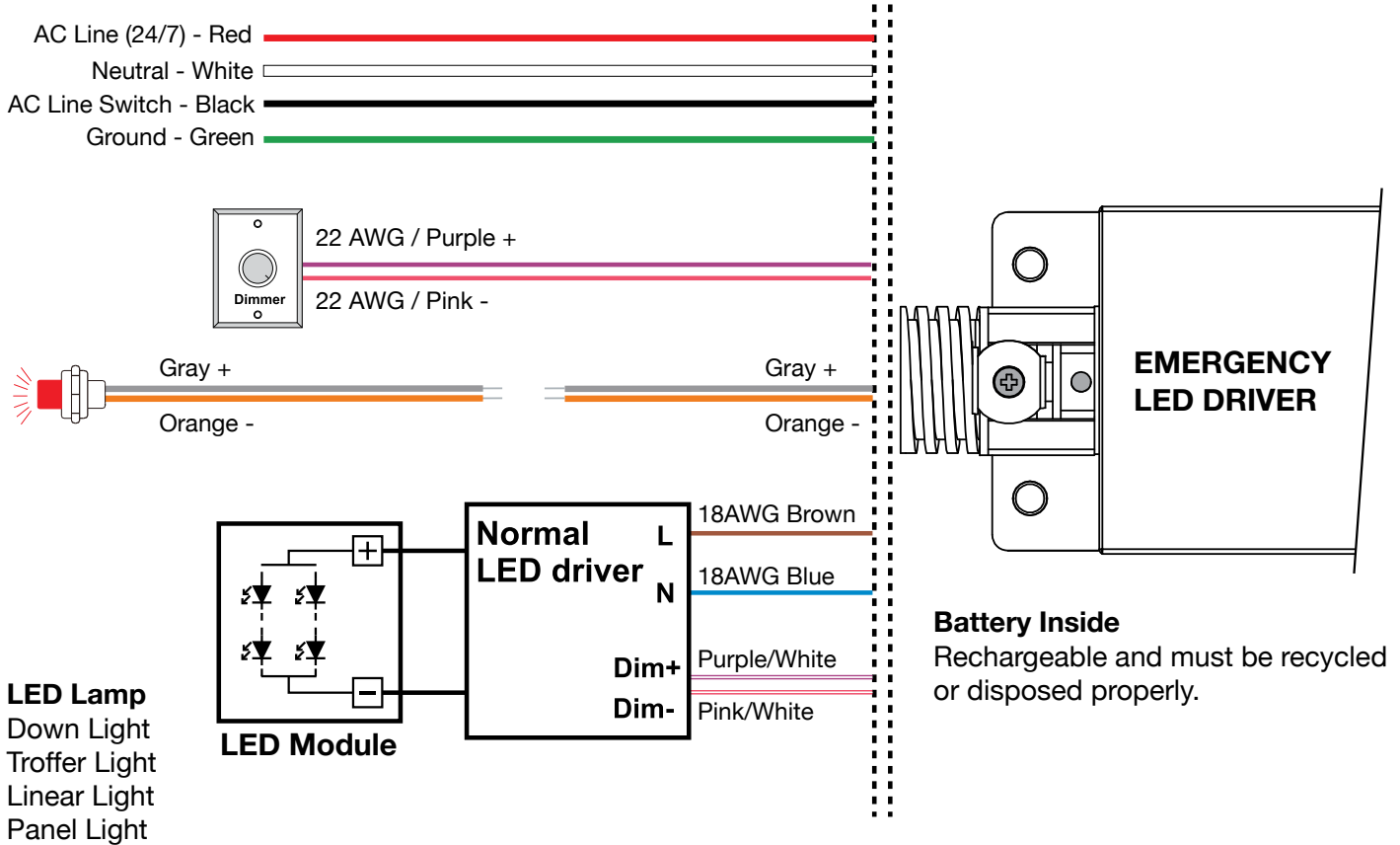

TEST SWITCH AND LED INDICATOR



Red Stable: Charging mode
Charging fully
OFF: Emergency mode

INDICATOR LIGHT	STATUS	COMMENT
Red slow flash (2 seconds on, 2 seconds off)	Battery Capacity not enough	Need to Continue Charging
Red Stable	Charging Mode, Fully Charged	AC Mode, Unit is Operating Correctly
Flashing 2 Times	Battery Error	Battery Discontinued or Battery Failure
Flashing 3 Times	Charging Error	Battery Voltage Abnormal
Flashing 5 Times	Temp Error	Temperature Abnormal
Continuous Flashing	LED Load Abnormal	Compatibility Test Fail

TEST SWITCH

Press switch to enter into emergency mode, release to recover charging mode.

REST MODE

Rest Mode can ensure battery long time storage, leakage current is very low in rest mode.

- Press and hold the test switch for over 3 seconds in the emergency mode to enter into rest mode.
- In rest mode, the battery is completely disconnected from the inverter, and the small leakage current can make its storage time longer.

CANCEL FAULTY MODE

- Press test button in charging mode to cancel faulty mode.

INSTALLATION SAFETY

- PLEASE INSTALL THIS PRODUCT PROPERLY BY THE LICENSED ELECTRICIAN.
- PLEASE CHECK AND CONFIRM ALL THE DATA AND USAGE SURROUNDING BEFORE INSTALLATION.
- THIS ITEM COULD BE USED IN THE SEALED FIXTURES OR INSTALLED OPEN AREA OF THE FIXTURES.
- PLEASE KEEP IT AWAY FROM THE FLAMMABLE MATERIALS WITH A PLACE OF GOOD HEAT DISSIPATION.
- PLEASE CHARGE THE BATTERY CONSISTENTLY FOR >24 HOURS FOR THE FIRST TIME USAGE SO AS TO ACTIVATE THE WHOLE BATTERY CELLS OF DISCHARGING/CHARGING DURATION.