

LED LOW PROFILE SURFACE DISK LIGHT MOUNTING INSTRUCTIONS

⚠ WARNING

Risk of fire - Supply conductors (power wires) connecting the fixture must be rated minimum 194°F if uncertain, consult an electrician.

Risk of electric shock disconnect power at fuse or circuit breaker before installing or servicing.

Risk of fire/electric shock, If not qualified, consult an electrician.

TOOLS REQUIRED



Ladder



Safety Glasses



Electrical Tape

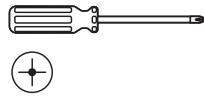

Phillips Screwdriver

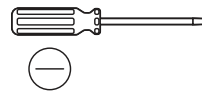

Flat Screwdriver



Pliers

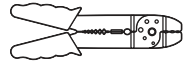

Wire Strippers

HOUSING INSTALLATION

Attach two mounted screws into outlet box leaving enough of the screw exposed to engage keyholes in the top of disk light. (Figure 1)

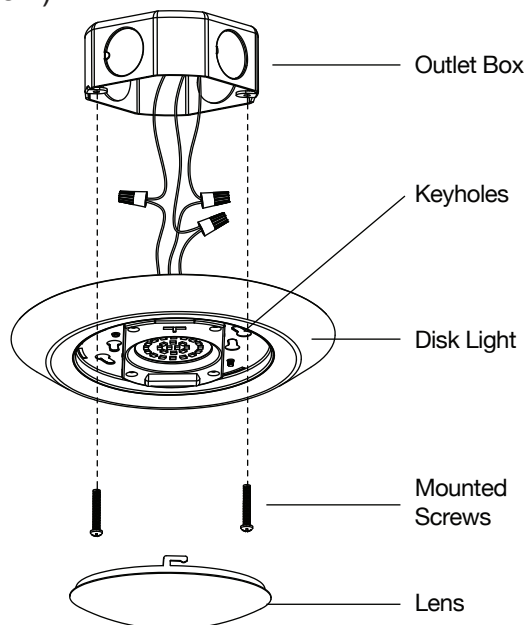

ELECTRICAL CONNECTION

1. Provide electrical service according to the “National Electrical Code” or your local electrical code to the outlet box.
2. Connect supply wires to fixture wires and insulate with proper size wire nuts. (Figure 1).
 - A. Connect incoming ground wire (green or bare) to fixture ground wire (green or bare)
 - B. Connect incoming common (white) wire to fixture common (white).
 - C. Connect incoming hot (black) wire to fixture black wire.

LENS INSTALLATION

1. Select desired color temperature using the CCT switch located on the LED module.
2. Align tabs on lens with notches on disk light housing. Twist to lock lens into place. Ensure lens is properly installed.