

Vertikale Ballenpresse
Vertical baling press



APV

300

500

Ausgereifte Technologie Sophisticated technology

Robuste, leistungsstarke vertikale Ballenpresse für hohe Ballengewichte auf kleinstem Raum. Einfache Bedienung durch automatisch öffnende Schiebetür, Textdisplay in jeweiliger Landessprache, sowie vollständiger Ballenauswurf mittels Gurt. Ballenumreifung wahlweise mit PE-Band oder Draht.

Strong and highly efficient vertical baling press for high bale weights in minimum space. Easy handling through digital text display, automatic bale ejection and automated sliding door. Bale strapping either with PE tape or steel wire.

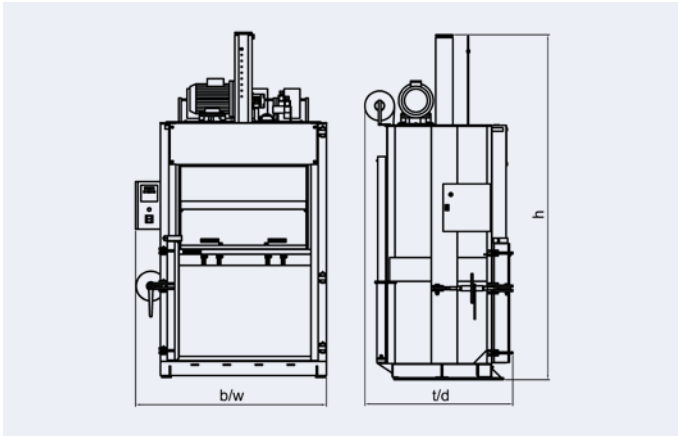

Technische Daten / Technical data

		APV 300	APV 500
Presskraft Pressing force	kN	300	500
Antrieb 400V Motor 400V	kW	5,5	7,5
Presszyklus Cycle time	sec	45	50
Presskammer bxtxh Box size wxdxh	mm	1200x800x1550	1200x800x1550
Füllöffnung Loading aperture	mm	1090x570	1090x570
Füllhöhe Loading height	mm	1100	1100
Ballenformat lxbtxh Bale dimensions lwxhx	mm	1200x800x1000	1200x800x1000
Ballengewicht Bale weight	kg	300-400	300-500
Bindung Strapping		4v	4v
Abmaße bxtxh Overall dimensions wxdxh	mm	1620x1260x2920	1620x1260x2920
Transporthöhe Shipping height	mm	2150	2150
Gewicht Total weight	kg	1650	1930

Technische Änderungen vorbehalten - Technical data subject to change



CE Conform/Conformity

Produktpalette / Product range

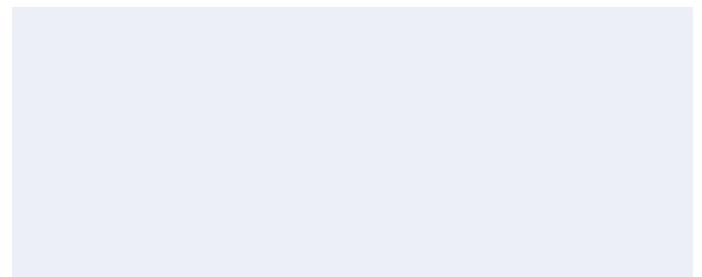

Roither Maschinenbau GmbH
4863 Seewalchen, Austria
Industriegebiet 11
Tel.: +43 (0)7662/8218
Fax: +43 (0)7662/8218 21
sales@austropressen.com
www.austropressen.com

