

Knitting Traditions



KNITTING TO SURVIVE

Stories from around the World and 21 Inspired Projects

Make this
Tree of Life Aran Vest

COLORWORK
Celebration
Fair Isle, Bohus, Sanquhar & More

Read the Diary of a Shetland Knitter

SPRING 2014

Broaden YOUR PERSPECTIVE, *deepen* YOUR KNOWLEDGE.



Beth Brown-Reisel



Candace Eisner-Strick



www.INTERWEAVEKNITTINGLAB.com

REGISTER NOW!

MAY 15-18, 2014

Radisson Hotel Manchester
MANCHESTER, NEW HAMPSHIRE

DISCOVER unique regional, ethnic and historical techniques and traditions through three days of classes and seminars—all presented by a roster of recognized knitting luminaries. Join us to deepen your knowledge of knitting history and expand your technical horizons. Plus, shop the Knitters' Market for unique yarns, patterns, tools and other knitting treasures!

LEARN from renowned instructors, including Beth Brown-Reinsel, Annie Modesitt, Katrine Wohllebe, Lily Chin, Shirley Paden, Alasdair Post-Quinn, and many more! NEW this year, 2-day intensive workshops.

KNIT around the world in four days with classes to broaden and deepen your knitting skills. Study Lace Motifs with Donna Druchunas, Shaped Intarsia with Daniela Nii, or try the Argyle Sock class, taught by Anne Berk.



Knitting Daily TV's **Vickie Howell** will be at Knitting Lab 2014 with a special event you won't want to miss!



Visit www.INTERWEAVEKNITTINGLAB.com to sign up today!

To learn more about sponsorship and exhibiting opportunities, contact:
Dana Groves • 610-232-5707 • Fax: 610-232-5754
dgroves@interweave.com



contents

Stories, Projects & Techniques

- 8** Aran Knitwear: The Myth and the Misty Reality—*Anne Carroll Gilmour*
- 13** Tree of Life Aran Vest—*Anne Carroll Gilmour*
- 19** Kempin Like Mad: Diary of a Shetland Knitter—*Hazel Tindall*
- 23** Slyde Cardigan—*Hazel Tindall*
- 27** The Telling Treasures of Uyeasound—*Elizabeth Lovick*
- 31** Uyeasound Table Runner—*Elizabeth Lovick*
- 33** By the Dexterous Use of Two Threads: Gloves and the Handknitting Industry of Sanquhar, Scotland—*Angharad Thomas*
- 37** Prince of Wales Sanquhar Gloves—*Angharad Thomas*
- 41** Winter: A Sanquhar Glove Pattern—*Beth Brown-Reinsel*



8



41

64



86



96



103

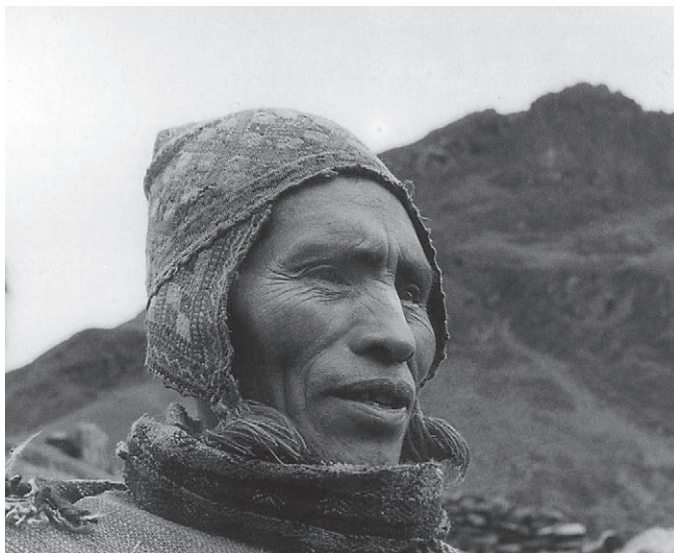

112



37

contents, *continued*

81



90



106



71



77

- 45** Knitting Stockings in Wales—*S. Minwel Tibbott*
- 47** Welsh Socks with a Quirk—*Judy Alexander*
- 50** Teaching the Poor to Knit: Knitting Teachers in England from the Sixteenth to the Nineteenth Century—*Lesley O'Connell Edwards*
- 56** On the Promenade: The Lace Knitting of Haapsalu, Estonia—*Nancy Bush*
- 60** Kajakakiri Stole—*Aime Edasi, Pille Källe, Nancy Bush*
- 64** Binge: Industrious Knitting in South Sweden—*Carol Huebscher Rhoades*
- 68** Binge Bjärbo Cap from Sweden—*Carol Huebscher Rhoades*
- 71** The Industry of Women: Emma Jacobsson and Bohus Stickning—*Courtney Kelley*
- 74** Vävanden Handwarmers—*Courtney Kelley*
- 77** Knitting in Macedonia: Survival and Creativity—*Jasemin Nazim*
- 81** Colorwork Hat from Macedonia—*Stanka Dimitrova*
- 83** Made for a Prince: The Sixteenth-Century Stocking Trade—*Chris Laning*
- 86** Barnim-Style Stockings—*Anne DesMoines*
- 90** Working with Wool: A Coast Salish Legacy & the Cowichan Sweater—*Sylvia Olsen*
- 96** Salish Fusion Fingerless Gloves and Salish Fusion Toque—*Sylvia Olsen*
- 99** Oomingmak Musk Ox Producers' Cooperative: Qiviut Lace in Alaska—*Donna Druchunas*
- 103** Arctic Tundra Scarf—*Donna Druchunas*
- 106** Dainty Work for Profit
- 112** Ancestral Memory: Knitting in the Shadow of Mount Ausangate—*Linda Ligon*
- 119** Knitting with Dignity: The Molo Wool Project in Kenya—*Gwen Meyer*

Departments

- 4** Letter from the Editor
- 124** Abbreviations & Techniques
- 128** Sources for Supplies



Pescadito

Contrarian Shawls

~ a new eBook

10 Unique Shawls to Knit & Crochet
using Fibra Natura yarns.



Whisper Lace
50 g/440 yds
70% wool, 30% silk

UNIVERSAL YARN
WWW.UNIVERSALYARN.COM

Available exclusively in local yarn stores.

Fleece made for sunny day play!



FREE KNIT PATTERN!
Download from brownsheep.com

Cotton Fleece is our coolest natural fiber yarn with 80% cotton and 20% merino wool to make it soft, wonderful to handle and perfect for those sunshine-warm days. Find Cotton Fleece in 60 inspiring colors at www.brownsheep.com



**Brown Sheep
Company, Inc.**

MITCHELL, NEBRASKA

✿ From the Editor ✿

Over the last five hundred years, amidst changing political, socio-economic, and cultural landscapes—and often because of grim personal circumstances—knitters across the world have taken up needles and yarn to sustain themselves, to feed their children, to pay the bills.

In *PieceWork's* eighth edition of *Knitting Traditions*, we pay tribute to these determined individuals as well as an array of cottage industries and cooperatives that have turned to knitting for income.

In this issue, you will meet Ceceila, a Cowichan knitter in western Canada who recalls knitting into the early hours of the morning by candlelight, knowing the sweater she finishes for sale will keep her children from going hungry; and James Moar, an invalid in 1880s Shetland, who learned to knit from his sisters, so he could contribute to the family income. You will discover the powerhouse stocking knitting trade that flourished in Wales for over two hundred years and the knitting cottage industries of Macedonia that have thrived from the nineteenth century to the bustling markets of today. You also will meet the Swedish social reformer, Berta Borgström, who formed a knitting cooperative to help women in need and to preserve her country's traditions.

As I pass my own stitches leisurely from one needle to the next these days, I wonder at how different my outlook is to these admirable women and men who used their handwork skills to quietly, steadily transform their lives—and still do. I am not being paid by the stitch, I have no quota to fill, my household stability is not dependent on my knitting production. Yet, as I think how knitting is, for me, a quiet meditation in a hectic world, so it was for many of them. In it, there was the work, yes, but also hope and possibility—rich pay, indeed. And this is why what we all earn with the work of our hands endures.

For help in holding my stitches in place while editing this issue, I owe special thanks to Anita Osterhaug, editorial director; Linda Ligon, creative director; and especially to Jeane Hutchins, *PieceWork* editor, for her wisdom and good humor. The 1879 historic Avery House in Fort Collins, Colorado, provided an ideal backdrop for photographing the inspirational projects, and we're grateful to Kristine Hart for her kind assistance there.

Knit on!

Karen Brock

Knitting Traditions

 INTERWEAVE.

EDITOR Karen Brock

EDITOR-IN-CHIEF, PIECEWORK Jeane Hutchins

EDITORIAL DIRECTOR Anita Osterhaug

CREATIVE DIRECTOR Linda Ligon

TECHNICAL EDITORS Tracey Davidson, Daniela Nii,
Karen Frisa

COPY EDITOR Veronica Patterson

EDITORIAL ASSISTANT Abbi Byrd

ASSOCIATE ART DIRECTOR
Samantha Wranosky

PRODUCTION DESIGNER
Nichole Mulder

PHOTOSTYLING Ann Swanson

VICE PRESIDENT, CONTENT
Helen Gregory

ADVERTISING MANAGER Stephanie Griess

MEDIA SALES TEAM MANAGER Diane Kocal

MARKETING MANAGER Annie Hartman Bakken

Knitting Traditions is a special issue of *PieceWork*® magazine (ISSN 1067-2249). *PieceWork* is published bimonthly by Interweave, a division of F+W Media, Inc., 201 E. 4th St., Loveland, CO 80537-5655. (970) 669-7672. USPS #011-717. Periodicals postage paid at Loveland, CO 80538, and additional mailing offices. Subscriptions: (800) 340-7496, email pckcustserv@cdsfulfillment.com. All contents of this issue of *Knitting Traditions* are copyrighted by F+W Media, Inc., 2014. All rights reserved. Projects and information are for inspiration and personal use only. Reproduction in whole or in part is prohibited, except by permission of the publisher.

Interweave Customer Service: (800) 272-2193

CONTACT PIECEWORK

Advertising: Stephanie Griess (877) 613-4630, sgriess@interweave.com; or visit pieceworkmagazine.com.

Retailers: If you are interested in carrying this magazine in your store please contact us:
Toll free (866) 949-1646
Email sales@interweave.com

Editorial inquiries: (970) 776-1448, piecework@interweave.com.

pieceworkmagazine.com

Interweave
201 E. 4th St.
Loveland, CO 80537
(970) 669-7672





- A unique gift of wearable masterpieces
- Eight times warmer than wool by weight

- Hand-knitted by over 200 Eskimo knitters
- Exclusive garments in Alaskan village patterns



OOMINGMAK
 Downtown Location • Corner of 6th & H
 Little brown house with musk ox mural
 604 H Street, Dept. PW, Anchorage, AK 99501
 (907) 272-9225 • www.qiviut.com





Strawberry Vines
 by June Dickinson
 Jamieson's Ultra



simply shetland
 Exclusive North American distributor of
 Jamieson's Shetland yarns
 Visit simplyshetland.com for your local retailer

Garments you'll wear over and over

Knit a collection of beautiful, wearable projects with *New American Knits* inspired by sportswear lines and New England colors.

New American Knits features 20+ everyday pieces designed by Amy Christoffers. Her garments have a casual elegance you'll swoon over with classic silhouettes, soft textures, and clean lines. *New American Knits* has the allure for those who enjoy a fun knitting project and those who crave a gorgeous finished piece.



Amy Christoffers
 160 Pages, \$24.99
 ISBN 13: 9781620330999

Order online at InterweaveStore.com.



Textured Stitches to Swatch and Explore!

CELEBRATE ESTONIAN KNITTING

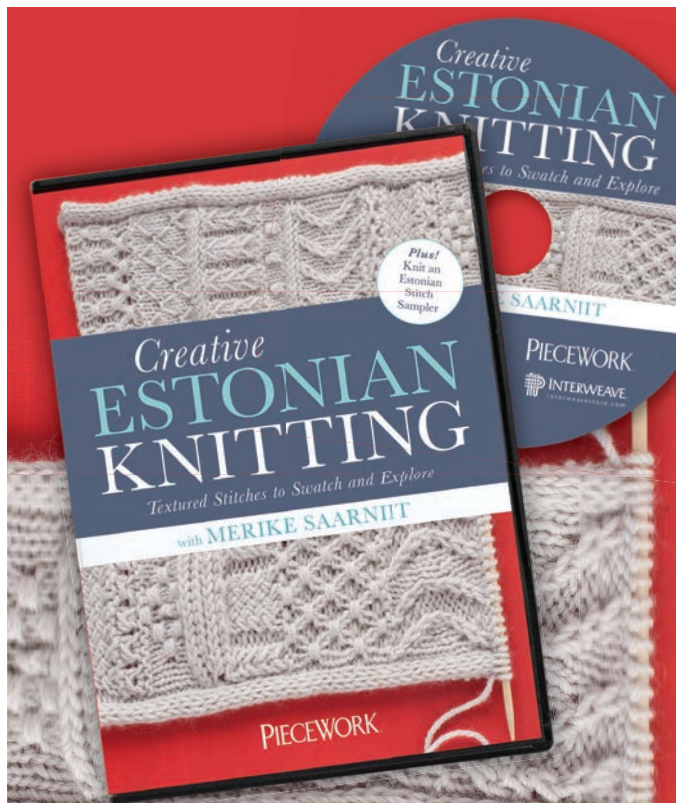

Merike Saarniit treasures the richness and creativity of her Estonian textile heritage. Reading the complex knitting patterns in her Estonian stitch dictionaries, Merike fell in love with the innovative designs and endless variations.

Learn to knit these beautiful patterns in this video workshop! In addition to the traditional stitches, you'll discover how Merike's innovative cast-on and selvedge treatments transform a swatch into a useful start for a hat, cuff, or even a sweater. With Merike's guidance, you will knit:

- Stretchy decorative elongated stitches
- Surprising stitch manipulations
- Several kinds of nupps
- Elegant horizontal and traveling patterns
- And more!

Plus! Follow along with Merike in this 90-minute video and make your own Estonian stitch sampler using the free pattern included with this workshop!

Available at your local yarn shop
or online at InterweaveStore.com.

 INTERWEAVE.

Founder, Creative Director Linda Ligon
Vice President, Group Publisher Shahla Hebets
Vice President, Content Helen Gregory
Vice President, Media Sales Julie Macdonald
Design Manager Larissa Davis
Senior Production Manager Nancy Pollock
Book Editorial Director Allison Korleski
Ecommerce Marketing Director Evelyn Bridge
Director, Magazine Marketing and Fullfillment Mark Fleetwood
Online Circulation Specialist Jodi Smith



F+W Media, Inc.

Chairman & CEO David Nussbaum
Chief Operating Officer/Chief Financial Officer James Ogle
President Sara Domville
Chief Digital Officer Chad Phelps
Vice President, eCommerce Lucas Hilbert
Senior Vice President, Operations Phil Graham
Vice President, Communications Stacie Berger

Interweave Main Office
201 E. 4th St.
Loveland, CO 80537
(970) 669-7672

Visit our websites at interweave.com • fwmedia.com

Interweave Magazines

Beadwork
Cloth Paper Scissors
CPS Studios
Drawing
Handwoven
Interweave Crochet
Interweave Knits
Lapidary Journal Jewelry Artist
Knitscene
PieceWork
Quilting Arts
Spin-Off
Step by Step Wire Jewelry
Stitch
Stringing

TREENWAY
silks
www.treenwaysilks.com

Camelot Chateau yarn (silk/camel blend)
Knitted by Diane de Souza 2012

LACE WEIGHT KNITTING YARNS
100% Silk and Silk Blends

Lakewood, CO • USA • toll-free 1.888.383.silk (7455)

KELBOURNE
PURVEYORS OF FINE YARN
WOOLENS
est. 2008 yarn usa

LENTEN ROSE
by Kate Gagnon Osborn
featuring The Fibre Company
Road to China Light

visit the pattern page for a video tutorial
on the Roositud technique!
kelbournewoolens.com/patterns/lenten-rose

Introducing
craft daily!

Watch your favorite workshop
videos on-the-go with streaming
video from Craft Daily

Visit www.CraftDaily.com to start viewing today!

✿ Aran Knitwear: ✿ The Myth and the Misty Reality

ANNE CARROLL GILMOUR



A photograph from Dr. Alfred Cort Haddon and Charles R. Browne's "Anthropometric Survey of the Irish Race." 1896. Not only were British commercially made ganseys seen in the Aran Islands, but Scottish bonnets were very popular as well. Photograph by Charles R. Browne © The Board of Trinity College Dublin, Ireland.

“ . . . And this man will not be nameless when we claim him from the swell. / There is so much more to this man's life than the pattern can ever tell.”

Title song from *The Pattern* CD by Willson and McKee. 1995. Used by permission of Kim McKee.

Much has been written and sung of the Aran sweaters that gained widespread popularity in the United States and Europe in the mid-twentieth century. Alas, most of it has proven to be erroneous romantic notions about the sweaters' age-old Celtic origins and unsubstantiated tales of identifying drowned fishermen by ancient “secret” family patterns stitched into their ganseys. To borrow words from Kim McKee's beautiful song “The Pattern,” there is “so much more” to the story of Aran knitwear.

How did the rumors and conjecture begin? In 1936, the first documented garment that could be classed as an Aran sweater was purchased in Muriel Gahan's Country Workers Ltd., a Dublin shop opened in 1930 to promote respect for rural craft workers and to provide an outlet for their goods. Heinz Edgar Kiewe, a textile writer and London shop owner, purchased the sweater. He proceeded to wax rhapsodic over his "discovery," planting the seeds of the designs' ancient Celtic origins by asserting that the figures in the *Book of Kells*, a ninth-century gospel, were wearing cabled Aran handknits from head to toe. Soon stories began to emerge about astoundingly talented eighth-century knitters who had worked from jealously guarded elaborate family patterns handed down through generations and used to help identify unfortunate seafarers washed up on distant shores. This last assumption may have sprung from a similar story being circulated about British seamen's ganseys but no substantial evidence corroborates either theory.



A group of Blasket Islanders standing in front of a cottage. These Aran men are wearing commercially made British ganseys. 1905. Photograph by John Millington Synge © The Board of Trinity College Dublin, Ireland.

It's a pretty story, but therein squats the toad. The tale was perpetuated and embellished by yarn manufacturers' publicists, shop owners, journalists, and by Kiewe himself, who published his "findings" in a book called *The Sacred History of Knitting: Recent Discoveries by Heinz Edgar Kiewe*. Kiewe admitted that he made no attempt to claim his assumptions as scholarly theory. He wrote to Richard Rutt (as related in Rutt's book *A History of Handknitting*), "I never romanticized, yet never felt forced to believe in written documents during my 55 years of research in textile history." He simply dismissed any need to authenticate his claims. Thus, Aran knitting was provided with a ready-made ancient history, and the marketing machine grabbed that ball and ran with it.

These popular myths were further encouraged when the style was adopted as stage costume by the Clancy Brothers and Tommy Makem, who exploded onto the vigorous folk-music scene that topped the charts in Britain and America in the 1960s. By this time, the first handknitting pattern for an Aran sweater had already appeared in a 1956 issue of *Vogue Knitting*; the sweater was produced by none other than Elizabeth Zimmermann, following printed instructions from the publisher. That the myths persist today some believe bears witness to a "blarney factor" in an industry that's simply sticking with successful advertising and marketing copy.

Although great for marketing, these notions about the patterns were largely debunked in later years, most recently by the rediscovery in 2012 of Dr. Alfred Cort Haddon and Charles R. Browne's "Anthropometric Survey of the Irish Race," an odd but thoroughly photo-documented scientific study of carefully selected communities of the Gaeltacht (Irish-speaking region) from 1891 to 1900. The documentary photographs of Aran villagers provide convincing evidence that Aran knitwear in any recognizable form didn't exist before or during that time.

What the survey's photographs clearly do show is that by 1897, fishermen in the Blasket Island region (adjacent to the Aran Isles off the Dingle peninsula in Kerry) were sporting well-worn commercially produced fishermen's ganseys. These photographs are especially valuable in that they portray seamen in their working garments; the images aren't staged photographs for which one would wear one's best gansey. The fine-gauge, close-fitting, and hard-wearing dark blue sweaters were being produced for sale by contract knitters in the west-coast port towns of northern Britain from as early as the 1840s. These

Aran knitting was provided with a ready-made ancient history, and the marketing machine grabbed that ball and ran with it.

working garments and the more ornate Scottish ganseys seem the most probable forerunners of what eventually would be known as the Aran Fisherman Sweater.

The survey also includes several 1892 photographs of Aran men (and one of a little boy) wearing typical commercially knitted and fulled Scottish bonnets. However, other than the dark blue sweaters, the Scottish bonnets, and the indigo stockings that were being handspun, dyed, and knitted by the women of Aran for family use, no other knitwear is greatly in evidence.

Just how did we get from workaday indigo stockings in 1891 to the exuberantly patterned white Aran Fisherman's Sweater well known today in the span of only some forty-odd years? Well, Heinz Edgar Kiewe was correct that the origins have been lost in the mists of time—only much more recently than he postulated. Several viable theories exist, and since the sweater's development is possibly within someone's living memory, information sharing is crucial to coming closer to the truth.

Imagine the wind-swept, stony Aran Islands of 1891, forty-five years before the first documented Aran sweater was seen in Muriel Gahan's Dublin shop window. Ireland was still reeling from post-famine recovery as well as from mass emigration, political upheaval, and the poverty and disenfranchisement these situations forced on peasant populations. Enter the Congested Districts Board with its good intentions to "Alleviate poverty and congested living conditions in the west of Ireland." The three Aran Islands—Inishmor, Inishmaan, and Inisheer (Inis Mór, Inis Meáin, and Inis Oírr in Irish, meaning Big Island, Middle Island, and East Island, respectively)—are located off the west coast at the mouth of Galway Bay. They actually were somewhat sparsely populated, but the rocky soil still made growing enough food to feed the population extremely difficult, and the fishing industry was faltering.

One of the board's main goals was to develop and encourage gainful employment for Aranites, thus decreasing the rate of emigration. At this time, the island women were already producing miles of homespun yarn for their own families, which they took to the local weaver for making up into *báinín* (natural white) flannel, from which most of their clothing was made. They also reserved some yarn for the indigo-dye kettle for stockings.

These sturdy blue stockings were the most often-mentioned article of handknitted clothing made on the Aran Islands before the mid-1930s. Another well-documented article of clothing was the heavy flannel petticoat, handwoven in red wool. This madder-dyed workhorse of a garment was used as skirt, cloak, bedding, swaddling for children, packing for a leaky *curragh* (small boat), and more. It often was worn over the head like an oversized hood, echoing the Kinsale cloak.

Like many such well-intended ventures that would require substantial change, all didn't go as planned. The board's attempts to get the Aran women to spin finer, softer, and more commercially viable yarn and refine their stocking-knitting skills to accommodate standard sizing and urban shoes (rather than the practical cowhide *pampooties* they normally wore) were of no interest to the pragmatic island knitters. The tough little sheep they raised, similar to the Scottish Blackface, were a long-stapled and whiskery lot that the islanders valued for the hard-wearing (if somewhat scratchy to less hardy folk) wool they provided.

One can only imagine how the islanders must have felt, being invaded by armies of do-gooders while dodging crews of invasive researchers. It must have seemed strange to them, by turns both amusing and annoying. As a result of the interest in improving the fishing industry, however, some very important visitors arrived: a herring-boat builder from Scotland, and three herring lassies. These women could not only gut, skin, and pack herring in seconds, they also could produce unique and highly textured Hebridean style ganseys expertly. They had needles at the ready during any downtime waiting for a catch. A most likely theory, told beautifully in Alice Starmore's detailed and well-researched book *Aran Knitting*, is that they shared both skills with the island women.

Starmore relates this as speculation, but anyone who has ever been part of a social knitting circle can guess what might have happened next. During their brief but impactful stay, the herring lassies inspired island knitting to take a creative new turn that spread like wildfire. As a possible offshoot of the attempt to improve the fishing industry, Aran knitwear as we know it today began to evolve. This is one believable theory, but there are others.

Sturdy Aran sheep on the Aran Island of Inishmor valued by the islanders for their hardwearing wool. Many modern Aran knitwear manufacturers now use much softer imported Merino wool. Photograph by and courtesy of the author.



In 1991, Rohana Darlington published her own explorations into the origins of the Aran style in *Irish Knitting*, wherein she relates a story that a woman from Inishmore told her. The woman stated that her mother and another island woman lived in the United States for a time and had learned cabling techniques from another foreign woman, who lived on an island off the coast of Boston in 1908. The trouble with this theory is that the same woman seems to contradict her own story in Deirdre McQuillan's *The Aran Sweater*. In that book, the author records the woman from Inishmore stating that her mother began to copy the jerseys she saw in American shop windows, but she preferred to try the exciting new stitch patterns in the thicker island handspun: the lighter shade showed off the texture better than dark blue millspun gansey wool and the thicker yarn worked up much more quickly. These are believable theories too—though the Aran knitters already would have been exposed to the crossed- and cabled-stitch patterns of commercial British ganseys years before 1908.

Though we may never know exactly how this knitted art form evolved, several factors have contributed to its story: socio-economic changes in Ireland and Europe between 1891 and 1936; scientific studies of the Aran people; the Irish struggle for home rule (1922–1923) and the subsequent surge in Irish national pride (not to mention reviving a culture and identity that had been oppressed for generations); World War I (1914–1918); events leading up to World War II (1939–1945); and advances in technology and modern conveniences. All of these elements affected life on the Aran Islands.

Perhaps most immediate for the people of Aran was that the weavers (usually men) were going off to war, to

jobs overseas, to any number of opportunities elsewhere. In the meantime, the women were still spinning miles of white wool. They didn't need to make as many stockings, had these beautiful stitches to experiment with (inspired by the herring-gutter gals, overseas sojourns, or perhaps just one really talented and creative knitter), had time on their hands—and were being encouraged to knit more. With the glories of nature and breathtaking old carved stone in their beautiful, albeit harsh island surroundings, it's not surprising that they wound up with such a striking and glorious art form. It certainly requires no false history or hype, no unlucky waterlogged sailors, no ancient Celtic monks.

Each of these theories may hold threads of truth. Even Mr. Kiewe was not entirely guilty of trying to pull the wool over anyone's eyes; he was sincere in his beliefs, as were many who encountered his printed works.

My own experience in the Aran Isles in 1999 tends to corroborate the Starmore theory and a similar incident related in Rohana Darlington's book. At the Aran Sweater Market and Museum in Kilronan on Inishmore, I was assisted by a lovely local woman. She immediately noticed the gansey I was wearing, which was Hebridean in style, heavily textured from the waist to the shoulders in cables and knit-purl texture motifs, with all the usual classic seamless techniques. When she politely asked how it was constructed, I quickly took it off for her to examine. She nodded and said wistfully, "This is how we once made them here, but nobody remembers how anymore."

Indeed she was right. The modern Aran sweater is pieced together dressmaker style, often handled by several different knitters—some on the mainland, some per-



The back view of a typical cardigan purchased at the Aran Sweater Market in Kiltonan, Inishmore, Aran Islands in 1999. Contemporary commercially produced Aran sweaters often sport pieced raglan construction, honey-comb and diamond motifs, as well as moss stitch and rope cables. The dizzying array of fashionable Aranwear styles available today online and through mail order are truly worthy of their proud (if somewhat recent) Island heritage. Photograph by and courtesy of the author.

haps on the islands, with some sections even worked by machine. The yarn has long since ceased to be handspun and is often imported merino, much softer than the wool the island sheep were known for. Decades ago, the demand for these beauties became much more than the island knitters could keep up with. By the 1970s, producing them had grown from a small cottage industry to a thriving business that involved mills, factories, and contract knitters from all over Ireland. It is rare now to find Aran sweaters completely handknit of local wool on the Aran Islands, even if that's how they might seem to be represented—with stories of ancient Celtic origins, drowned sailors, and secret family patterns intact. Such iconic stories call to mind the enigmatic words of Father Peter Lonergan in *The Quiet Man*, John Ford's cinematic love letter to Ireland: "Well, I can't say it's true, and I won't say it's not. . . ." ❀

Further Resources

Carville, Justin. "The Deviant Face: Photography in Alfred Cort Haddon and Charles R. Browne's Anthropometric Survey of the Irish Race." In *The Irish Headhunter*. www.heritagecouncil.ie/fileadmin/user_upload/Publications/Education/The_Irish_Headhunter_catalogue.pdf.

Congested Districts Board for Ireland. www.ovguide.com/congested-districts-board-for-ireland-9202a8c04000641f80

000000003c8a8a.

Darlington, Rohana. *Irish Knitting: Patterns Inspired by Ireland*.

London: A & C Black, 1991. Out of print.

Kiewe, Heinz Edgar. *The Sacred History of Knitting: Recent Discoveries by Heinz Edgar Kiewe*. Oxford: Art Needlework Industries, 1971. Out of print.

Lawless, Emily. *Grania: The Story of an Island, Volumes 1 & 2*. 1892. Reprint, Charleston, South Carolina: BiblioBazaar, 2011.

McQuillan, Deirdre. *The Aran Sweater*. Belfast, Northern Ireland: Appletree Press, 1993.

Rutt, Richard. *A History of Hand Knitting*. 1987. 2nd ed. Loveland, Colorado: Interweave, 2003.

Starmore, Alice. *Aran Knitting*. 1997. Expanded ed. Mineola, New York: Dover Publications, 2010.

Zimmermann, Elizabeth. *Knitting Around*. Pittsville, Wisconsin: Schoolhouse Press, 1989.

ABOUT THE AUTHOR AND DESIGNER. Anne Carroll Gilmour lives in the Wasatch Mountains near Park City, Utah, where she works in her studio and teaches workshops in spinning, weaving, and knitting. Her work has appeared in print and online as well as in galleries worldwide. A first-generation American, she readily admits that her Celtic roots and love of history show up frequently in her designs. Visit her website at www.wildwestwoolies.com.

A companion project follows

Tree of Life Aran Vest

ANNE CARROLL GILMOUR

Inspired by the preceding article

Using the seamless construction and individualized detail of the earliest Aran sweaters, Anne Carroll Gilmour's Tree of Life vest is a stunning tribute to both the myth and the reality of Aran knitting. Photograph by Joe Coca.

Machines now produce most modern Aran knitwear, using dressmaker-style assembled flat pieces. Earlier examples, however, were handknit seamlessly with individualized variations front to back and attention to small details and symmetry.

For this project, offered in three adult sizes for male or female, we look back to those exceptional earlier Arans by eliminating side seams, using mirror-image symmetry on cable and crossed stitches, and featuring a coordinating design variation on the back. To maintain symmetry toward the center back cable, don't be surprised when the instructions for the right front say to cable or cross to the left and vice versa.

Materials

Kerry Woolen Mills Aran Knitting Wool, 100% wool yarn, 3-ply, Aran weight, 365 yards (333.8 m)/200 gram (7.1 oz) hank, 2 (3, 4) hanks of Natural White; www.dublinbay.net

Needles, circular, 24 inches (60.0 cm), sizes 5 (3.75 mm) and 7 (4.5 mm) or size needed to obtain gauge

Cable needle

Stitch holders, 1 long (or extra circular needle) and 4 short

Stitch markers

Tapestry needle

Buttons, 1 inch (2.5 cm), 5

Small amount of contrasting yarn

Finished sizes: About 35¼ (40, 46¾) inches (90 [102, 119] cm) chest circumference, buttoned

Gauge: 17 sts and 23 rows = 4 inches (10.2 cm) in Irish Moss patt on larger needles; 30 sts of Double Diamond chart = 5½ inches (14.0 cm) wide; 19 sts of Right Front Cable chart = 2¾ inches (7.0 cm) wide

Special Abbreviations

RT (right twist)—slip 1 stitch onto cable needle, hold in back, knit 1 through the back loop, purl 1 from cable needle

LT (left twist)—slip 1 stitch onto cable needle, hold in front, purl 1, knit 1 through the back loop from cable needle

Instructions

Notes: See above and page 124 for Abbreviations and Techniques. The vest is worked back and forth in one piece from the lower edge to the underarm, then the upper fronts and back are worked separately.

Welt

With smaller needle and the long-tail method, CO 145 (167, 189) sts. Do not join.

Set-Up Row (WS): P2, *k3, [p1 tbl] 3 times, k3, p2; rep

from * to end.

Next Row (RS): K2, *work Twisted Tree Chart over 9 sts, k2; rep from * to end.

Next Row (WS): P2, *work Twisted Tree Chart over 9 sts, p2; rep from * to end.

Work 22 (28, 34) more rows in patt, ending with Row 6 of chart.

Body

Size 35¼ inches (90 cm) only,

Set-Up Row 1 (RS): K2, work Twisted Tree Chart as established over 9 sts, pm, work Set-Up Row 1 of Right Front Cable Chart over 13 sts, pm, work Set-Up Row 1 of Right Zigzag Chart over 9 sts, pm, M1p, k2, M1p, pm, k1, p1, M1, p1, [k1, M1p] 2 times, k1, p1, M1, p1, k1, pm, M1p, k2, pm, work Twisted Tree Chart as established over 9 sts, pm, k2, M1p, pm, k1 tbl, p1, M1, p1, k1 tbl, [M1p, k1 tbl] 2 times, pm, work Set-Up Row 1 of Double Diamond Chart over 19 sts, pm, [k1 tbl, M1p] 2 times, k1 tbl, p1, M1, p1, k1 tbl, pm, M1p, k2, pm, work Twisted Tree Chart as established over 9 sts, pm, k2, M1p, pm, k1, p1, M1, p1, [k1, M1p] 2 times, k1, p1, M1, p1, k1, pm, M1p, k2, M1p, pm, work Set-Up Row 1 of Left Zigzag Chart over 9 sts, pm, work Set-Up Row 1 of Left Front Cable Chart over 13 sts, pm, work Twisted Tree Chart as established over 9 sts, k2—190 sts.

Sizes 40 (46¾) inches (102 [119] cm) only,

Set-Up Row 1 (RS): K2, work Twisted Tree Chart as established over 9 sts, pm, work Set-Up Row 1 of Right Front Cable Chart over 13 sts, pm, work Set-Up Row 1 of Right Zigzag Chart over 9 sts, pm, M1p, k2, M1p, pm, *k1, p1, RT, k1 tbl, LT, p1, [k1, M1p] 3 times; rep from * 0 (1) more time(s), k1, p1, RT, k1 tbl, LT, p1, k1, pm, M1p, k2, pm, work Twisted Tree Chart as established over 9 sts, pm, k2, M1p, pm, k1 tbl, p1, M1, p1, k1 tbl, [M1p, k1 tbl] 2 times, pm, work Set-Up Row 1 of Double Diamond Chart over 19 sts, pm, [k1 tbl, M1p] 2 times, k1 tbl, p1, M1, p1, k1 tbl, pm, M1p, k2, pm, work Twisted Tree Chart as established over 9 sts, pm, k2, M1p, pm, **k1, p1, RT, k1 tbl, LT, p1, [k1, M1p] 3 times; rep from ** 0 (1) more time(s), k1, p1, RT, k1 tbl, LT, p1, k1, pm, M1p, k2, M1p, pm, work Set-Up Row 1 of Left Zigzag Chart over 9 sts, pm, work Set-Up Row 1 of Left Front Cable Chart over 13

sts, pm, work Twisted Tree Chart as established over 9 sts, k2—210 (238) sts.

All sizes,

Set-Up Row 2 (WS): P2, work Twisted Tree Chart as established over 9 sts, sl m, work Set-Up Row 2 of Left Front Cable Chart over 19 sts, sl m, work Set-Up Row 2 of Left Zigzag Chart over 9 sts, sl m, k1, p2, k1, sl m, [p1, k1] 6 (11, 18) times, p1, sl m, k1, p2, sl m, work Twisted Tree Chart as established over 9 sts, sl m, p2, k1, sl m, [p1 tbl, k1] 4 times, p1 tbl, sl m, work Set-Up Row 2 of Double Diamond Chart over 30 sts, sl m, [p1 tbl, k1] 4 times, p1 tbl, sl m, k1, p2, sl m, work Twisted Tree Chart as established over 9 sts, sl m, p2, k1, sl m, [p1, k1] 6 (11, 18) times, p1, sl m, k1, p2, k1, sl m, work Set-Up Row 2 of Right Zigzag Chart over 9 sts, sl m, work Set-Up Row 2 of Right Front Cable Chart over 19 sts, sl m, work Twisted Tree Chart as established over 9 sts, p2.

Next Row (RS): K2, work Twisted Tree Chart over 9 sts, sl m, work Right Front Cable Chart over 19 sts, sl m, work Right Front Zigzag Chart over 9 sts, sl m, work Mock Cable Left Chart over 4 sts, sl m, work Irish Moss Chart over 13 (23, 37) sts, sl m, work 1st 3 sts of Mock Cable Left Chart, sl m, work Twisted Tree Chart over 9 sts, sl m, work last 3 sts of Mock Cable Left Chart, sl m, work Right Zigzag Chart over 9 sts, sl m, work Double Diamond Chart over 30 sts, sl m, work Left Zigzag Chart over 9 sts, sl m, work 1st 3 sts of Mock Cable Right Chart, sl m, work Twisted Tree Chart over 9 sts, sl m, work last 3 sts of Mock Cable Right Chart, sl m, work Irish Moss Chart over 13 (23, 37) sts, sl m, work Mock Cable Right Chart over 4 sts, sl m, work Left Zigzag Chart over 9 sts, sl m, work Left Front Cable Chart over 19 sts, sl m, work Twisted Tree Chart over 9 sts, k2.

Note: Once you have established the main pattern charts, worked a few rows, and the patterns are better developed, you may remove the markers between charts, if desired.

Work even in patt through Row 48 of Zigzag Charts—piece measures about 12 (13, 14) inches (30 [33, 36] cm) from CO.

Divide for Fronts and Back,

Next Row (RS): Work 50 (54, 61) sts in patt and place these sts on holder for right front, BO 3 sts, work in patt to last 50 (54, 61) sts, place last 50 (54, 61) sts on holder for left front, turn—87 (99, 113) sts rem for back.

Back,



The back of Anne Carroll Gilmour's Tree of Life Aran Vest, showing the Twisted Tree, Zigzag, and Double Diamond patterns. Photograph by Joe Coca.

Next Row (WS): BO 3 sts, work in patt to end—84 (96, 110) sts rem.

BO 2 sts at beg of next 2 rows, then BO 1 st at beg of foll 2 (6, 10) rows—78 (86, 96) sts rem.

Work even in patt until armhole measures about 10 inches (25 cm), ending with Row 8 of Double Diamond Chart and Row 40 of Zigzag Charts. Work 4 rows in patt, working Rows 1–4 of Double Diamond Chart and working all other charts as established—armhole measures about 10½ inches (27 cm), ending with Row 44 of Zigzag Charts.

Shape shoulders with short-rows as foll,

Dec Row (RS): Work 26 (30, 35) sts in patt, sl 1, k2tog, pssso, ssk, k3tog, p8, sl 1, k2tog, pssso, k2tog, k3tog,

work to last 4 sts, wrap next st, turn—10 sts dec'd.

Left shoulder,

Short-Row 1 (WS): Work 14 (16, 18) sts in patt, turn.

Short-Row 2 (RS): Work to last 7 sts, wrap next st, turn.

Next Row (WS): Work 11 (13, 15) sts. Break yarn.

Place 18 (20, 22) left shoulder sts on holder. Place center 32 (36, 42) sts on holder for back neck—18 (20, 22) sts rem for right shoulder.

Right shoulder,

With WS facing, rejoin yarn at right neck edge.

Short-Row 1 (WS): Work to last 4 sts, wrap next st, turn.

Short-Row 2 (RS): Work to end.

Short-Row 3: Work to last 7 sts, wrap next st, turn.

Next Row: Work to end.

Place right shoulder sts on holder.

Left front,

Notes: Armhole and neckline shaping happen at the same time. Read the following section all the way through before proceeding. Work all patterns as established as closely as possible while working both the armhole and neckline shaping.

Return 50 (54, 61) held left front sts to needle. With RS facing, rejoin yarn.

At beg of RS rows, BO 3 sts once, then BO 2 sts once, then BO 1 st 1 (3, 5) times—6 (8, 10) sts dec'd at armhole edge.

At the same time, shape neckline.

Dec Row (RS): Work to last 3 sts, k2tog, k1—1 st dec'd at neck edge.

Rep Dec Row every RS row 25 (25, 28) more times—18 (20, 22) sts rem after all shaping is complete. Work even in patt until armhole measures about 10½

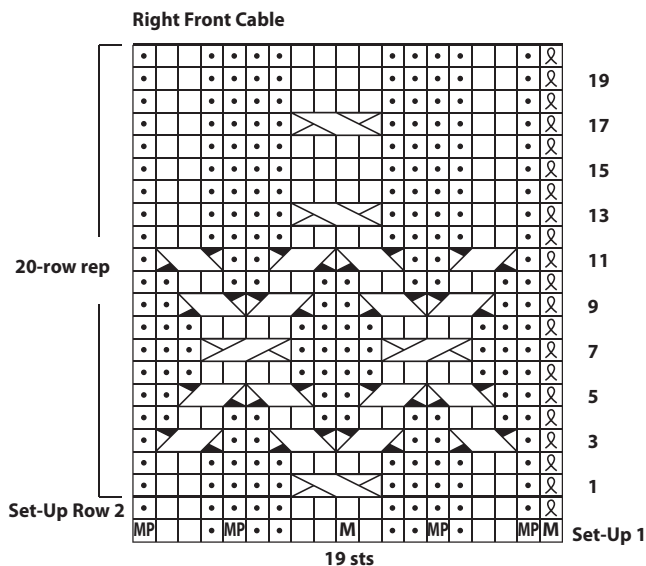
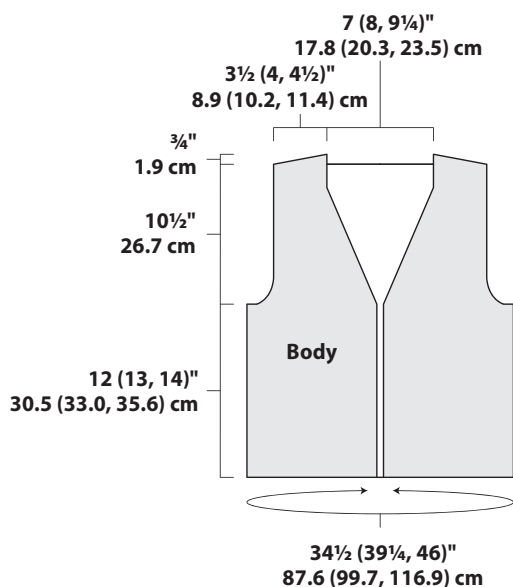

inches (27 cm), ending with Row 45 of Zigzag Chart.

Shape shoulder with short-rows as foll,

Short-Row 1 (WS): Work to last 4 sts, wrap next st, turn.

Short-Row 2 (RS): Work to end.

Short-Row 3: Work to last 7 sts, wrap next st, turn.

Next Row: Work to end.

Place all sts on holder.

Right front,

Notes: Armhole and neckline shaping happen at the same time. Read the following section all the way through before proceeding. Work all patterns as established as closely as possible while working both the armhole and neckline shaping.

Return 50 (54, 61) held right front sts to needle. With WS facing, rejoin yarn.

At beg of WS rows, BO 3 sts once, then BO 2 sts once, then BO 1 st 1 (3, 5) times—6 (8, 10) sts dec'd at armhole edge.

At the same time, shape neckline.

Work 1 WS row.

Dec Row (RS): K1, ssk, work to end—1 st dec'd at neck edge.

Rep Dec Row every RS row 25 (25, 28) more times—18 (20, 22) sts rem after all shaping is complete. Work even in patt until armhole measures about 10½ inches (27 cm), ending with Row 44 of Zigzag Chart.

Shape shoulder with short-rows as foll.

Short-Row 1 (RS): Work to last 4 sts, wrap next st, turn.

Short-Row 2 (WS): Work to end.

Short-Row 3: Work to last 7 sts, wrap next st, turn.

Next Row: Work to end.

Place all sts on holder.

Join shoulders using 3-needle BO.

Right Zigzag

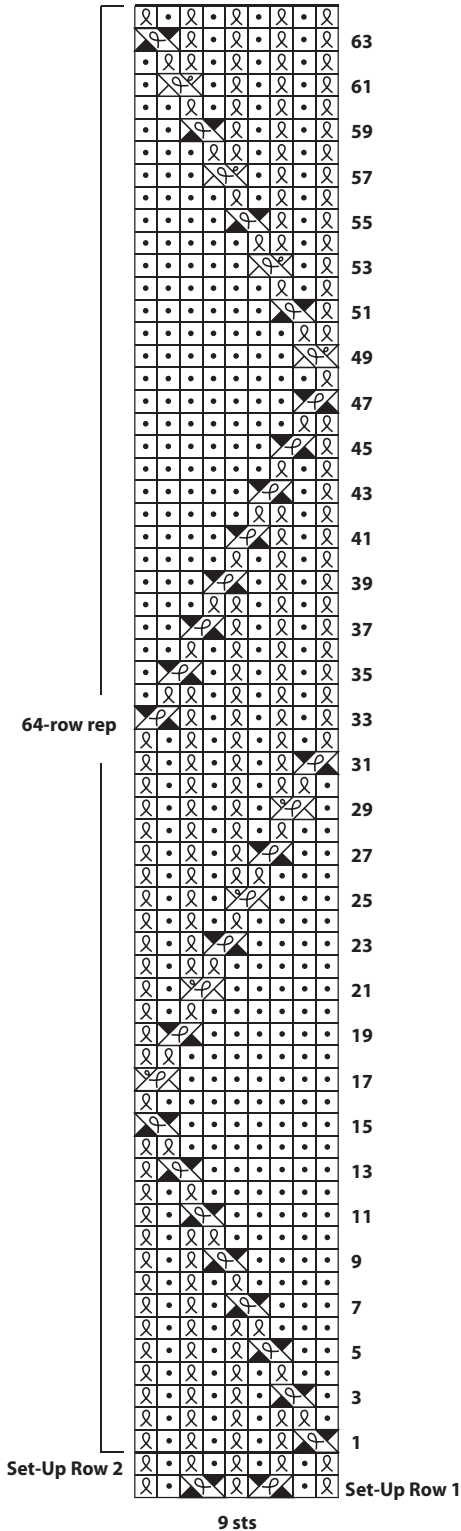

Front Band,

With smaller needles, RS facing, and beg at right front CO edge, pick up and k 54 (58, 62) sts along right front edge to beg of neckline shaping, pm, pick up and k 48 sts along neck shaping to center back neck sts, pm, work 32 (36, 42) back neck sts from holder as foll: sl 1, k2tog, pss0, work to last 3 sts, k3tog, pm, pick up and k 48 sts along left neck shaping to beg of neckline shaping, pm, pick up and k 54 (58, 62) sts along left front edge to CO edge—232 (244, 258) sts. Do not join.

Next Row (WS): K to m, sl m, M1, k to m, sl m, ssk, work to 2 sts before next m, k2tog, sl m, k to m, M1, sl m, k to end.

Mark buttonhole placement with contrasting yarn. *Notes:* Traditionally, buttonholes are on the left front for men and the right front for women. Five buttons are shown here, one near the beginning of the neck shaping and one close to the bottom of the welt, with the remaining three evenly spaced between them.

Rep last row, working 2-st 1-row buttonholes as marked. BO all sts pwise.

Armhole Edging,

With smaller needles, RS facing, and beg at center underarm, pick up and k 84 sts evenly around armhole. Pm and join in the rnd. P 1 rnd, then k 1 rnd. BO all sts kwise.

Sew on buttons opposite buttonholes.

Finishing

Weave in ends. Block to measurements. ❁

Double Diamond

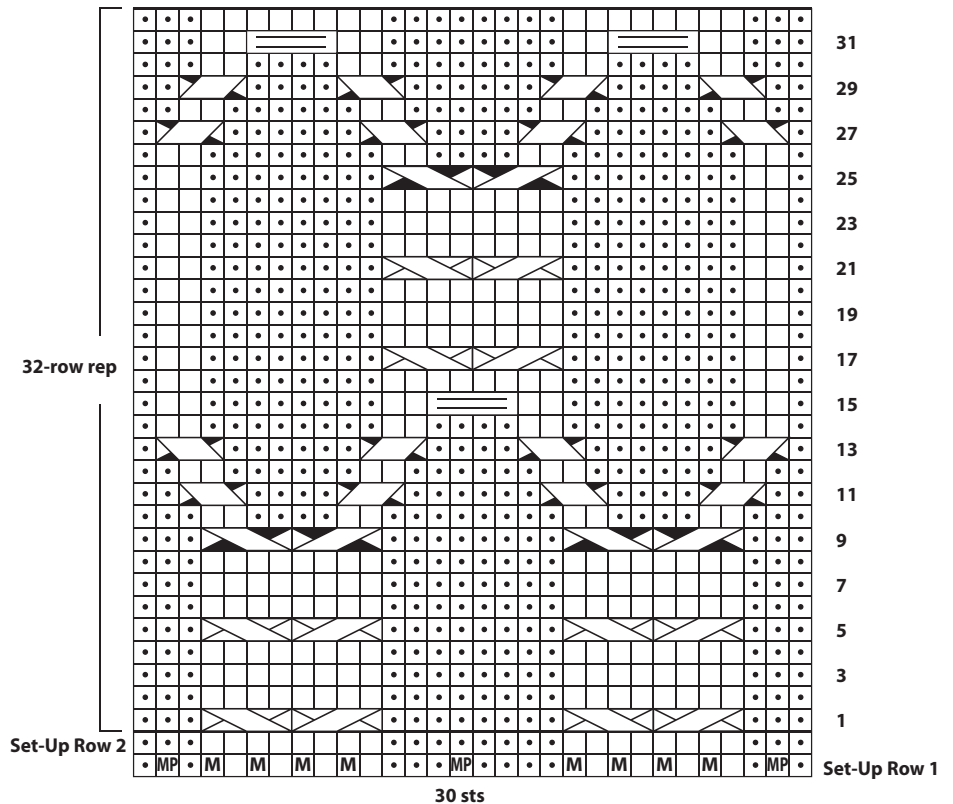

Left Zigzag

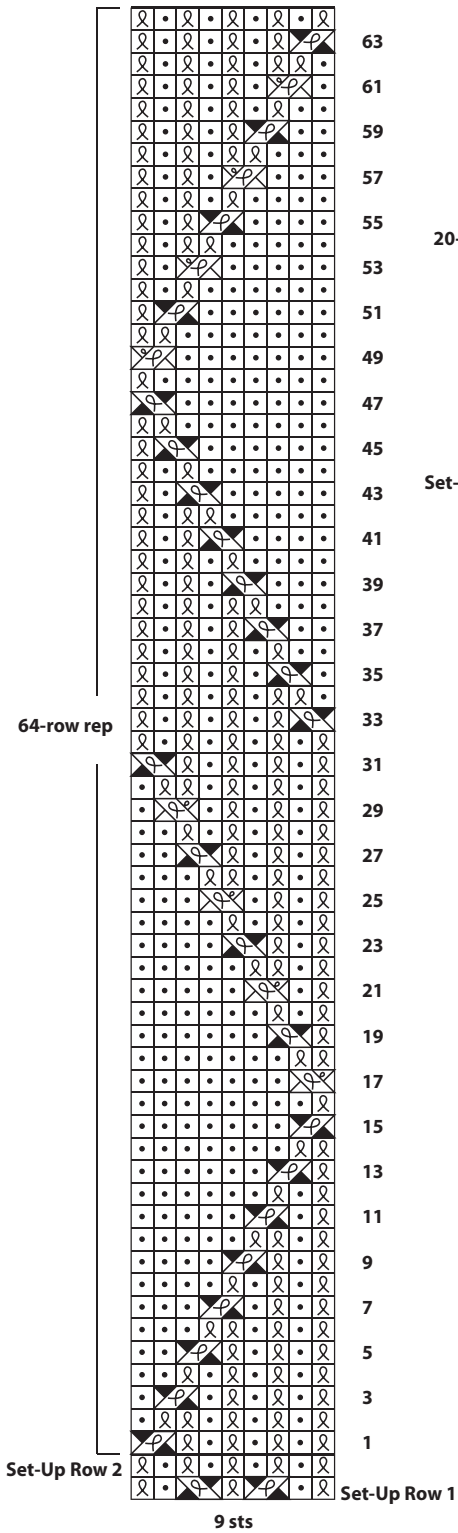

Left Front Cable

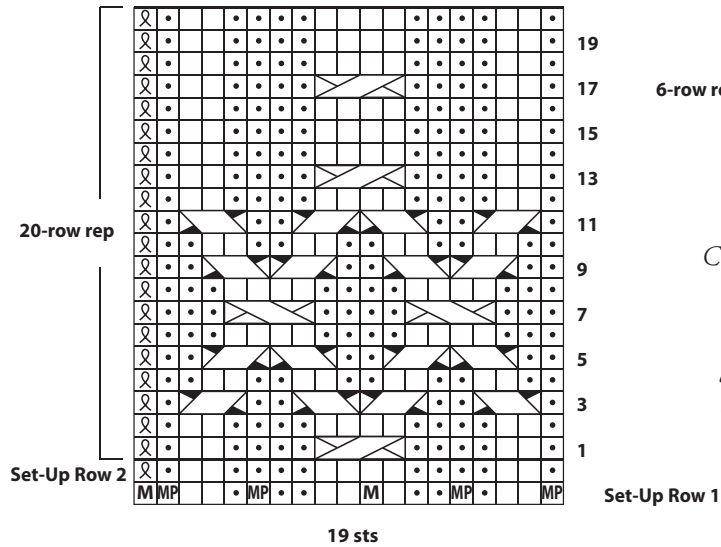

Twisted Tree

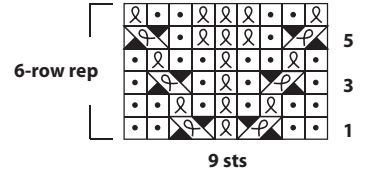

Charts may be photocopied for personal use.

The charts for this project are available in PDF format at pieceworkmagazine.com/Charts-Illustrations.

Key

- k on RS; p on WS
- p on RS; k on WS
- k1 tbl on RS; p1 tbl on WS
- M1
- M1p
- patt rep
- sl 1 st onto cn, hold in back, k1 tbl, p1 from cn (RT)
- sl 1 st onto cn, hold in front, p1, k1 tbl from cn (LT)
- sl 1 st onto cn, hold in front, k1 tbl, k1 tbl from cn
- sl 1 st onto cn, hold in back, k1 tbl, k1 tbl from cn
- sl 1 st onto cn, hold in back, k2, p1 from cn
- sl 2 sts onto cn, hold in front, p1, k2 from cn
- sl 2 sts onto cn, hold in back, k2, k2 from cn
- sl 2 sts onto cn, hold in front, k2, k2 from cn
- sl 2 sts onto cn, hold in back, k2, p2 from cn
- sl 2 sts onto cn, hold in front, p2, k2 from cn
- 4-st wrap—[sl next 4 sts to right-hand needle wyb, sl same 4 sts back to left-hand needle wyf] 2 times, k4
- k into the 2nd st on left-hand needle, do not sl st off needle, then k the 1st st on left-hand needle and sl both sts to right-hand needle at the same time
- k into the back of the 2nd st on left-hand needle, do not sl st off needle, then k the 1st st on left-hand needle and sl both sts to right-hand needle at the same time

Irish Moss

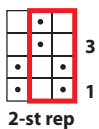

Mock Cable Left

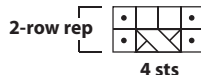

Mock Cable Right

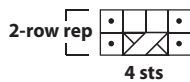

❁ Kempin Like Mad: ❁ Diary of a Shetland Knitter

HAZEL TINDALL

My mother, Chrissie Sandison (1917–2009), grew up in a remote part of Shetland, where the most common means of travel was by sea. She was the youngest of eight children. Before Chrissie's second birthday, her mother died, and her aunt, Ellen, became the mother figure in her life. Ellen was a hardworking widow who relied on knitting to contribute to the household needs. The ladies of the household were constantly knitting for sale, as well as to keep the family clothed. A jumper seemed always to be blocked and drying on a board.

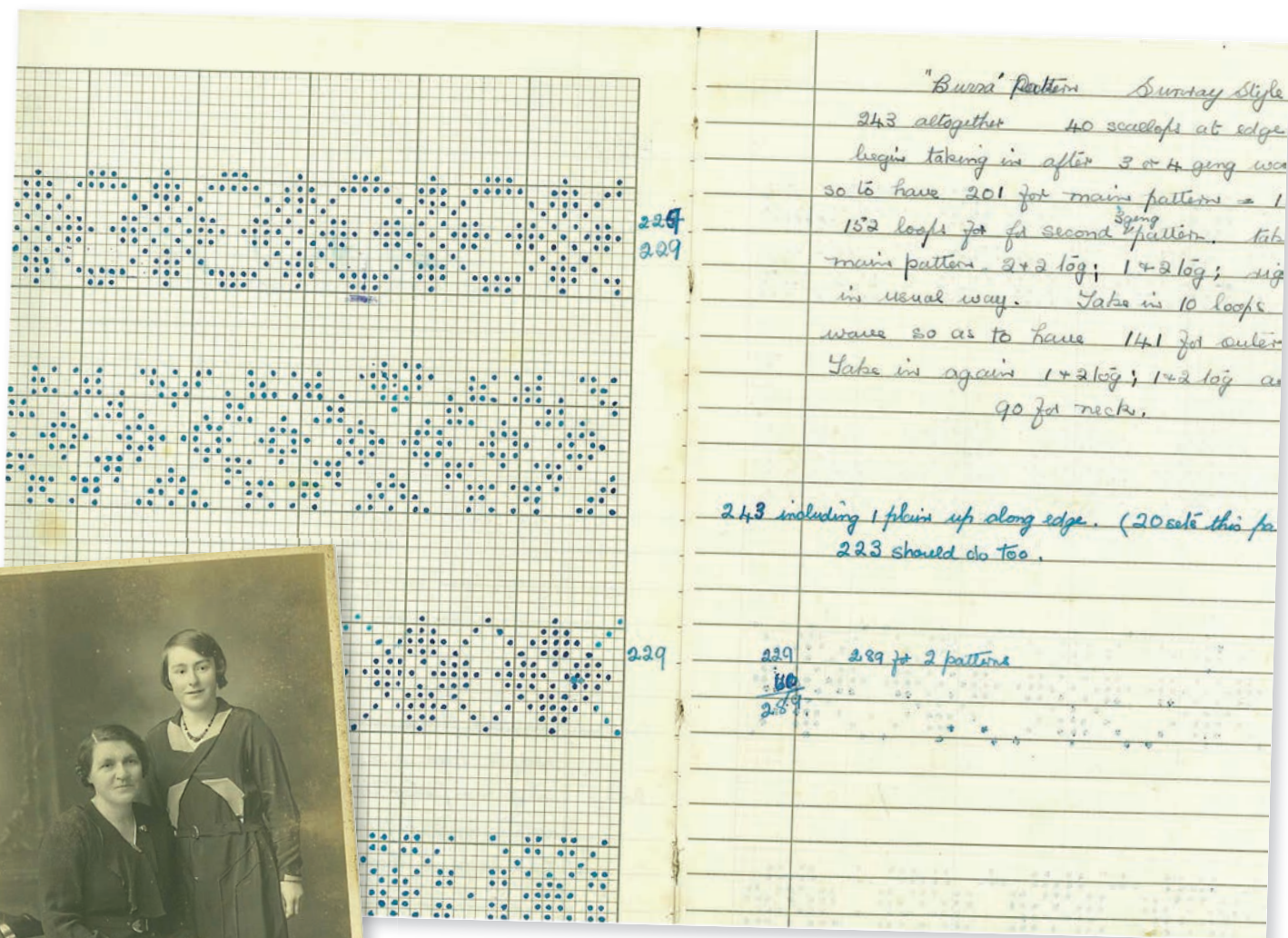

Above: A page from Chrissie Sandison's knitting notebook, showing the chart and instructions for the Burra pattern. Photograph courtesy of the author.

Left: Chrissie Sandison at right, with her Aunt Ellen in Lerwick, Shetland. Circa 1930. Photographer unknown. Collection of the author. Photograph courtesy of the author.

Me aunt, ' she tocht she'd better gie
 A talk, on da facts a life!
 "I ken na what'll com o' de yet
 For du scarcely casts a loof;
 Du's aetin' de white bread noo, me lass
 O' dat: dir is nae doot
 It'll no aye be like dis, du ken's
 When de fadders hoase du lae's
 For dan'll hae de kye ta mylk,
 An' paist oot de fodder shaeves
 Dan du'll hae tae set de at an' mak'
 Tae kled de man - an' hain's feet
 God help him it gets de!
 He'll no hae his troubles tae seek
 My lass, du'll need tae leid de sok
 (It's maist serious dan it soonds)
 Dir nae edder wye, apon a croft
 Tae gadder up twartfee pounds
 So lay by zjan trashy book's du reads
 An' 'lark' at' de bit a sok;
 Dats da wye tae get some "klink"

Original text from Chrissie Sandison's poem "Da Facts o Life."

Knitted garments were taken by boat or on foot over the hills and bartered at shops for everyday goods such as tea, flour, and sugar. The shopkeeper was in a position of power, deciding whether to buy the knitting and, if purchased, what goods would be given in exchange. In the majority of cases, this transaction favored the shopkeeper.

Chrissie's early and harsh realization of knitting's value came in 1929. Two of her brothers went by boat to take a parcel of knitting to the shop and to bring back one of her sisters, who had been visiting relatives. Not long after the brothers left, their boat capsized, and both drowned. The parcel of knitwear floated toward the shore, and neighbors retrieved it. In her book, *Slyde in the Right Direction*, Chrissie wrote, "It was my sad task to go there to collect the parcel—its contents were certainly far too valuable to abandon."

As Chrissie grew up, she preferred reading and writing to knitting. But her aunt was forever telling Chrissie that she needed to knit instead of read books. Here are a few lines from one of Chrissie's poems, "Da Facts o Life," in which she captures her aunt's frequently repeated advice (the language of the poem excerpts has been modernized for clarity; see the handwritten original shown above):

My aunt, she thought she'd better give
 A talk on the facts of life
 "I don't know what will become of you
 For you scarcely knit a stitch;
 You're eating your white bread now, my girl
 Of that there is no doubt
 It'll not always be like this, you know
 When your father's house you leave
 For then you'll have your cows to milk
 And share out the fodder sheaves
 Then you'll have to sit and knit
 To clothe your man, and children's feet. . . ."

Chrissie married in 1942 and had four children. Chrissie's husband, Jeemie, was a seaman until 1962, spending many months at a time away. Chrissie was at home caring for their four children and, with the help of Jeemie's unmarried sister, who lived with them, looking after their small croft. For Chrissie, as for others living in this rural community, paid work outside the home was not a possibility, so they relied on knitting to earn extra cash. Although Chrissie didn't enjoy knitting, the income from it was crucial, just as her aunt had said:

". . . My girl, you'll need to work at your knitting
 (It's more serious than it sounds)
 There's no other way upon a croft
 To gather a few pounds
 So lay aside those trashy books you read
 And work hard at your bit of knitting
 That's the way to get some money."

By the 1960s, the barter system had ended, so knitters found other outlets for their knitting, either through private contacts or with one of the various buyers in Lerwick, Shetland's main town. Again, the buyers had all the power; they could (and did on occasion) refuse to buy. My sisters and I helped to knit mittens and berets—small projects, almost certain to sell, that used up small amounts of colored yarn. Not only are mittens simple to knit, they're also easy to start when you're too tired to start something more complex but need to produce something for sale.

Because Fair Isle yoked jumpers and cardigans were in demand then, many households bought knitting machines so they could produce the bodies and sleeves for these sweaters quickly. Chrissie and Jeemie bought a knitting machine, and made long trips in snow to attend classes to learn how to use it. Neither of them enjoyed this endeavor, but they were lured to give it a try by neighbors and relatives who were knitting scores of

Excerpts from Chrissie Sandison's Diary 1961–1968

| | | | |
|-------------|---|-------------|--|
| 12 Jan 1961 | Worried a bit over cash situation. | 8 Sep 1965 | I knitted two on machine and I made a yoke and began a second one. We plan to get 10 ready for 25th. |
| 21 Feb 1961 | Knitting gloves. | 18 Sep 1965 | Doctor to see Alice [youngest daughter]—appendicitis so we took her to hospital. [Complications kept Alice in the hospital until October 6. Because the hospital had no parental accommodation, Chrissie, who didn't drive, managed just six visits.] |
| 3 Feb 1962 | This was a knitting Saturday. Thelma [oldest daughter] did the backs of a pair of gloves for herself so I was telling her that she could easily start knitting gloves to sell which would mean extra pocket money for her and a help to us as well. | 6 Oct 1965 | Happy to see Alice home. Tired tonight and no energy to knit or do anything. |
| 3 Mar 1962 | Thelma kempin [working hard to complete a piece of knitting] on white gloves. I will be happy when she gets a pair sold as it would encourage her to knit! | 15 Nov 1965 | Jeemie to hospital for gall bladder op [he got home on November 26th]. Bought myself black fur lined boots—almost £5. I will get them paid for from JA's twinset—I hope [JA, John Anderson, a relative of Chrissie's son-in-law; knitting for family was a common way of getting orders for knitwear.] |
| 19 Apr 1962 | Finished my 6th beret. | 4 Feb 1966 | Got all lumbers sold at 45 shillings each. Not much of the cash left but it's good to know I have no debts . . . |
| 2 May 1962 | Thelma managed to sell her gloves so it's still a help. | 8 Sep 1966 | Got cash for hosiery so I've got two bills paid off. |
| 11 Jan 1963 | Ordered knitting machine and put in names for lessons. | 28 Nov 1966 | Jeemie has been paid off today so that's not too good a prospect. We have a lot of things to get and Christmas in the offing so I will have to stick in at the hosiery—time is the biggest snag. |
| 29 Jan 1963 | To add to the other troubles our knitting machine arrived today, but seems complicated to me. | 3 Mar 1967 | J returned early owing to gale. It's really no weather for outside work. I'm on the rocks as usual. I don't suppose I'll ever have much water under my keel, yet I have aye managed somehow. I must make an all out effort to get to Lerwick with hosiery on Friday. |
| 9 Mar 1963 | To Lerwick. Disappointed to find mill closed (Saturday) and got no hosiery [handknitted garments] sold. I felt like kicking the blooming parcel right into the harbour. My kempin in vain. | 19 May 1967 | At Lerwick. Paid a lot bills so that's off my mind. |
| 22 Apr 1963 | Got 2 white lumbers [in Chrissie's world, a cardigan had a V-neck; lumbers or lumber-coats buttoned right up to the neck] sold. Sewed on buttons while visiting hospital. | 30 Jun 1967 | Hazel and I kempin so lots of chores left out. |
| 27 Apr 1963 | Spent nearly all my cash. Did some knitting—too tired and sleepy for much, but would need to knit to pay off some debts. | 1 Jul 1967 | Kempin like mad! Need to have been hoeing. |
| 1 Jan 1964 | This is a noanie [tiny] of a diary but I hope next year to be able to afford a better one than this. [The diary measured 2½ by 4 inches (6.3 by 10.2 cm).] | 26 Jul 1967 | Rained all day so I finished a whole lumber. That was a change! |
| 15 Feb 1964 | Got white lumbers sold so got debts paid. | 2 Dec 1967 | At Lerwick. Got most presents for Christmas. Spent all my money today so I'm broke though that's nothing new! |
| 23 May 1964 | At Lerwick. Lipper [an annoying person] refused to buy my white lumbers. | 5 Feb 1968 | 10 pairs of mittens to Lerwick. |
| 8 Feb 1965 | Got all my hosiery sold so that will square all my debts with a little over. | 24 Feb 1968 | I finished a lumber from grafting cuffs to the neck from 1 p.m. to 1 a.m. I was in a kempin mood. It won't last, that much is certain. |
| 11 Mar 1965 | Got 7 lumbers sold. Spent it all. | | |
| 16 Mar 1965 | I felt so weary but I got a yoke made nevertheless. | | |
| 23 Apr 1965 | I stuck in at knitting and got on a piece of a yoke. | | |
| 8 May 1965 | I kemped on a weird looking lumber. I hope I won't have to wear it on my own back . . . | | |



Chrissie Sandison's handknitted Fair Isle yoke with chart and notes. Chrissie cut yokes from sweaters she had knit for herself, after they had been worn so much she could no longer mend them, as a reminder of the design in case she wanted to reknit it. Collection of the author. Photograph courtesy of the author.

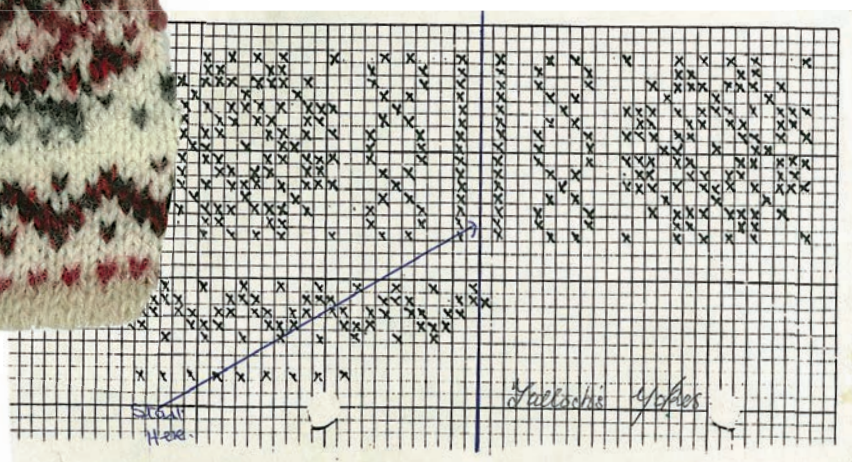

jumpers and cardigans each week. By the late 1960s, when plain cardigans and jumpers were needed, Chrissie grafted on cuffs and necks for sweaters that others made or to finish bodies and sleeves made on her own machine. This process was known as “feenishin.”

Chrissie started keeping a daily diary in 1961. Reading her diaries from the 1960s makes clear that she struggled to find time to knit goods to sell. You can almost hear her aunt’s words echo in the entries. Chrissie had neither checkbook nor credit card, so goods were bought from shopkeepers she knew who trusted her to make payment when she had cash. In the long days of summer, outside jobs took up time and energy, so most knitting was done in the winter months. As the decade ended, Jeemie’s paid employment finally became steadier, and Chrissie had less need to “kemp” (work). ❀

Further Reading

Abrams, Lynn. *Myth and Materiality in a Woman’s World: Shetland, 1800–2000*. Manchester, England: Manchester University Press, 2005.

Sandison, Chrissie. *Slyde in the Right Direction*. Lerwick, Shetland: The Shetland Times, 2008. Out of print.

ABOUT THE AUTHOR AND DESIGNER. Hazel Tindall was born and brought up in Shetland and has spent most of her life there. She is a lifelong knitter with a special interest in Fair Isle knitting. Her passion is sharing her knowledge through instruction both in the classroom and on DVDs and by writing patterns. Learn more about her at www.hazeltindall.com.



Chrissie Sandison in 1966. Photograph courtesy of the author.

A companion project follows

Slyde Cardigan

HAZEL TINDALL
Inspired by the preceding article



Slyde is the name of the croft (very small farm) where Chrissie Sandison was born. In the 1960s, especially, thousands of yoked sweaters and cardigans were knitted and exported from Shetland. Back then, the body and sleeves would have been machine-knitted and the yoke handknitted. This one is entirely handknitted.

The cardigan body is worked in one piece, back and forth; the sleeves are worked in the round. The yoke is knit from stitches from the body and sleeves, and a steek allows knitting the Fair Isle yoke in the round. After the yoke has been knitted, the remaining armhole openings are closed by picking up stitch-

es from the body sides and grafting them and underarm stitches to the sleeve stitches. The front edgings are knitted from stitches picked up from the side edges and easily could be changed to a button or zipper fastening if preferable. Neutral colors are suitable for a boy or girl.

Hazel Tindall's charming Fair Isle cardigan pays tribute to her mother's hard work earning money for the family through her knitting. The design is named after the croft in the Shetland Islands where her mother Chrissie Sandison was born. Photograph by Joe Coca.

Materials

Jamieson's Shetland Spindrift, 100% Shetland wool yarn, jumper weight, 115 yards (105.2 m)/25 gram (.88 oz) ball, 5 (6, 7) balls of #107 Mogit (MC) and 1 ball each of #336 Conifer (CC1), #140 Rye (CC2), #365 Chartreuse (CC3), and #390 Daffodil (CC4); www.simplyshetland.net

Needles, circular, 16 inches (40.0 cm) and 24 inches (60.0 cm), or double pointed, size 2 (2.75 mm) and size 3 (3.25 mm) or size needed to obtain gauge

Markers

Stitch holders

Clasps, 3

Tapestry needle

Blocking materials

Finished sizes: 26½ (29, 31) inches (67.3 [73.7, 78.7] cm) chest circumference

Gauge: 28 sts and 38 rows = 4 inches (10.2 cm) in St st on larger needle

Instructions

Notes: See page 124 for Abbreviations and Techniques. Stitches are kept on holders at various points; use stitch holders or strong cotton thread. Before beginning the yoke, take a moment to check that the sleeves are correct—the larger number of stitches next to the end-of-round marker should be adjacent to the back section. The yoke is knitted in the round with an eight-stitch steek. Steek stitches have been charted but are not included in the stitch counts. Where yoke rounds need just one color, either break the unused color or let it hang loose until it is needed again.

Rib

With smaller needle and MC, CO 173 (189, 205) sts. Do not join.

Row 1 (WS): P1, *k1, p1 tbl; rep from * to last 2 sts, k1, p1.

Row 2: K1, *p1, k1 tbl; rep from * to last 2 sts, p1, k1.

Rep Rows 1 and 2 four more times, then work Row 1 once more.

Body

Change to larger needle.

Row 1 (RS): K6 (14, 22), [M1, k23] 7 times, M1, k6 (14, 22)—181 (197, 213) sts.

Row 2: P.

Row 3: K.

Rep Rows 2 and 3 until 109 (119, 129) rows of St st have been worked (about 12¼ [13¼, 14¼] inches [31 (34, 36) cm] from CO).

Next Row (WS): P39 (43, 47), pm, p10, pm, p83 (91, 99), pm, p10, pm, p39 (43, 47).

Right Front after Armhole,

Row 1 (RS): K to 3 sts before m, k2tog, k1, place next 142 (154, 166) sts on holder—38 (42, 46) sts rem for right front.

Row 2: P.

Row 3: K to last 3 sts, k2tog, k1—1 st dec'd.

Rep Rows 2 and 3 three (six, six) more times—34 (35, 39) sts rem.

Next Row: P.

Place sts on holder.

Back after Armhole,

Place 1st 10 body sts on holder for underarm. Back is worked on next 83 (91, 99) sts.

Row 1 (RS): K1, ssk, k to last 3 sts, k2tog, k1—2 sts dec'd.

Row 2: P.

Rep last 2 rows 4 (7, 7) more times—73 (75, 83) sts rem.

Work 6 rows even.

Place sts on holder.

Left Front after Armhole,

Place 1st 10 body sts on holder for underarm. Left front is worked on next 39 (43, 47) sts.

Row 1: K1, ssk, k to end—1 st dec'd.

Row 2: P.

Rep last 2 rows 4 (7, 7) more times—34 (35, 39) sts rem.

Place sts on holder.

Sleeves,

With smaller needle and MC, CO 42 (44, 48) sts. Pm and join to work in the rnd.

Rnds 1–19: *K1 tbl, p1; rep from * around.

Change to larger needle.

Rnds 1–6: K.

Rnd 7: K1, M1, k to last st, M1, k1—2 sts inc'd.

Rep Rnd 7 every 8th rnd 5 (10, 11) more times—54 (66, 72) sts.

Work even until piece measures 12 (13, 14) inches (30.5 [33.0, 35.6] cm) from CO.

Left sleeve only,

Next Rnd: K44 (53, 59), place next 10 (13, 13) sts on holder, sl m, place next 13 (16, 16) sts on holder—31 (37, 43) sts rem for yoke.

Right sleeve only,

Next Rnd: K41 (50, 56), place next 13 (16, 16) sts on holder, sl m, place next 10 (13, 13) sts on holder—31 (37, 43) sts rem for yoke.

Yoke,

Transfer all sts from fronts, back, and sleeves onto spare needles.



The back of Hazel Tindall's Slyde Cardigan, showing the Fair Isle yoke. The yoke is knit with stitches from the body and sleeves, and a steek allows knitting the yoke in the round. Photograph by Joe Coca.

With MC and larger needle, CO 4 sts for steek, pm, with RS facing and beg at right front, k34 (35, 39), k31 (37, 43) right sleeve sts, k73 (75, 83) back sts, k31 (37, 43) left sleeve sts, k34 (35, 39) left front sts, pm, CO 4 sts for steek, pm (to indicate start/end of rnd) and join to work in the rnd—203 (219, 247) sts total, excluding steek sts.

With MC, k 0 (0, 2) rnds.

Work Rnds 1–4 of Bottom Border Chart.

Next Rnd: With CC2, k0 (0, 1), [k9 (15, 11), k2tog] 18 (12, 18) times, k5 (15, 12)—185 (207, 229) sts rem.

Work Rnds 1–16 of Yoke Chart—169 (189, 209) sts rem.

Next Rnd: With CC2, k1, [k2tog, k3] 33 (37, 41) times, k2tog, k1—135 (151, 167) sts rem.

Work Rnds 1–4 of Top Border Chart.

Next Rnd: BO 4 steek sts (st rem from BO is not included in foll instructions), k1 (0, 2), [k2tog, k1] 44 (50, 54) times, k1 (0, 2)—91 (101, 113) sts rem.

Using sharp scissors, cut center of steek to give a flat piece of work; this makes knitting the neck rib back and forth easier.

Change to smaller needle.

Row 1 (WS): P1, *k1, p1 tbl; rep from * to last 2 sts, k1, p1.

Row 2: K1, *p1, k1 tbl; rep from * to last 2 sts, p1, k1.

Rep Rows 1 and 2 four more times. BO all sts in patt.

Left Front Edging,

With RS facing, smaller needle, MC, and beg at left front neck edge, pick up and k 7 sts along edge of neck rib, 25 sts along edge of colorwork, pm, 61 (69, 75) sts along side of main body, and 6 sts along edge of lower rib—99 (107, 113) sts total.

Note: Stitch count may be different if you have altered the length.

Row 1 (WS): P1, *k1, p1 tbl; rep from * to m, remove m, [k1, p2tog tbl, k1, p1 tbl, k1, p2tog tbl] 3 times, [k1, p1 tbl] 3 times, k1, p1—93 (101, 107) sts rem.

Row 2: K1, *p1, k1 tbl; rep from * to last 2 sts, p1, k1.

Work 6 rows even in rib, ending with a RS row.

Loosely BO all sts in patt.

Note: The edging will look a bit tight but blocking will smooth it out.

Right Front Edging,

With RS facing, smaller needle, MC, and beg at right front lower edge, pick up and k 6 sts along rib, 61 (69, 75) sts along side of main body, 25 sts along colorwork, and 7 sts along rib—99 (107, 113) sts total.

Row 1 (WS): P1, [k1, p1 tbl] 3 times, [k1, p2tog tbl, k1, p1 tbl, k1, p2tog tbl] 3 times, *k1, p1 tbl; rep from * to last 2 sts, k1, p1—93 (101, 107) sts rem.

Row 2: K1, *p1, k1 tbl; rep from * to last 2 sts, p1, k1.

Work 6 rows even in rib, ending with a RS row.

Loosely BO all sts in patt.

Trim any loose ends from edge of steek. With CC1 threaded on the tapestry needle, sew cut edge of the steek to the wrong side of the yoke.

Close right underarm,

With RS facing, MC, and smaller needle, pick up 5 (8, 8) sts along right front armhole, k10 held underarm sts, pick up 8 (11, 11) sts along right back armhole—23 (29, 29) sts total. Transfer 23 (29, 29) held right sleeve sts to a knitting needle. Graft sts tog using Kitchener Stitch.

Close left underarm,

With RS facing, MC, and smaller needle, pick up 8 (11, 11) sts along left back armhole, k10 held underarm sts, pick up 5 (8, 8) sts along left front armhole—23 (29, 29)

sts total. Transfer 23 (29, 29) held left sleeve sts to a knitting needle. Graft sts tog using Kitchener Stitch.

Close any gaps where yoke, body, and sleeves meet.

Finishing

Using strong cotton and the tapestry needle, sew bind-off stitches of the front edgings together temporarily to make a tube. With right side facing, pass a separate strong cotton through neck edge of right front, edge of neck, and edge of left front. Tie ends of cotton in a bow. Wash in warm water. Squeeze to remove excess moisture.

Blocking

Block, stretching until sweater is completely smooth. Pull cotton in neck edge tighter and retie. Once it is dry, remove cotton from neck and front edgings. Sew on fastenings or zipper. 🌸

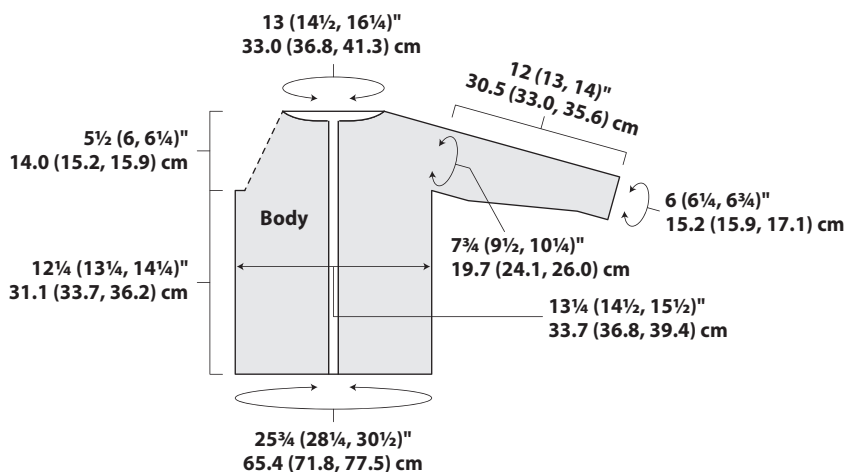

Bottom Border

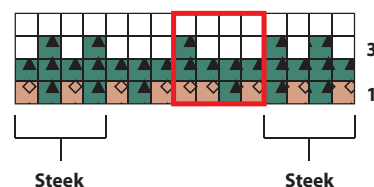

Top Border

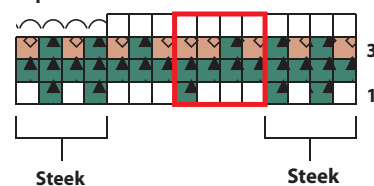

Yoke

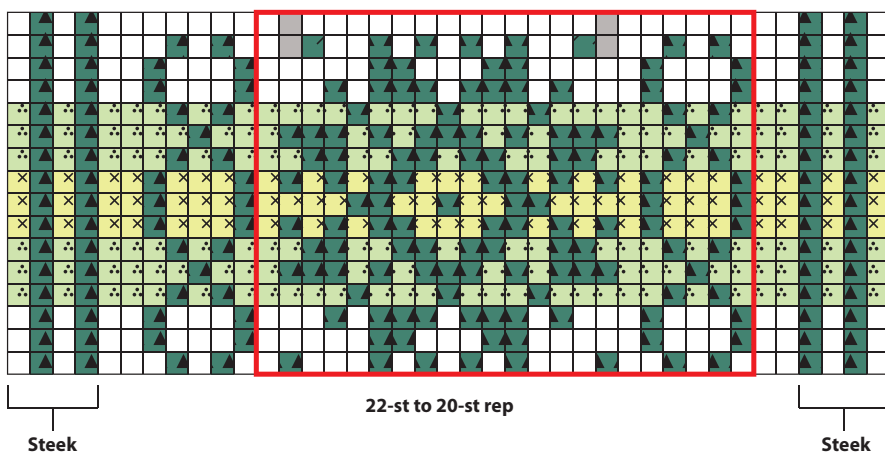

Key

- 15
- 13
- 11
- 9
- 7
- 5
- 3
- 1
- MC
- CC1
- CC2
- CC3
- CC4
- k2tog with CC1
- BO 1 st
- no st
- patt rep

Charts may be photocopied for personal use.

The charts for this project are available in PDF format at pieceworkmagazine.com/Charts-Illustrations.

✿ The Telling Treasures of Uyeasound ✿

ELIZABETH LOVICK



Unst, the northernmost island of the Shetland archipelago, has three main settlements: Haroldswick in the north, Baltasound mid-island, and Uyeasound in the south. It was at Uyeasound that a discovery made several years ago extended our knowledge of how knitting from this island, known worldwide for its fine knitted lace, was traded.

Shetland sheep resting on the Saxa Vord moor above Burra Firth, Unst. The sheep stay on the hills in all weather. Photograph by and courtesy of the author.

A shawl with a colored edging found in a box of knitted items in an out building of the former post office in Uyeasound, Shetland. The lace had been dyed after it was knitted, then sewn on. The brown would have been dyed with tea.

Photograph by the author and courtesy of the Unst Heritage Centre, Unst, Shetland.



For many years, Uyeasound had had a post office-cum-shop situated on the seafront at the end of the pier. When it closed, the owners Peggy Johnson and her brother John William Ritch emptied the shop and its associated buildings. At the back of one outbuilding was an old box containing knitted items and a letter dated May 17th, 1881, Unst, Shetland.

The letter was from James Moar (1856-1919) written to an unidentified woman with the implication that she would buy the knitted goods in the box. In the letter, Mr. Moar describes himself as an “invalid” of several years who lives with his widowed mother, no longer able to care for herself, as well as two sisters who were his only support. Determined to be “less bothersome to them” he learned to knit. His sister spun the yarn while he sat in bed and knitted lace.

We have no way of knowing whether the letter would have been sent with some or all of the items in the box. We also don’t know whether the story in the letter is accurate. Nevertheless, along with the knitted contents of the box, it offers an insight into knitting as an integral part of daily life in Unst in the late nineteenth century.

The box held a cross section of the types of articles knitted and traded on Unst: scarves and shawls, gloves, socks, and tray cloths. Collectively, such small knitted items were known as “hosiery,” a term not reserved for

leg wear. Some items were in remarkably good condition, but others had been attacked by moths or mice. Peggy Johnson, a lace knitter herself and involved with the Unst Heritage Centre in Haroldswick, gave the box of knitted items to the Unst Heritage Centre in 1993. Replicas of some items were knitted for display so that the originals could be kept safe from further deterioration.

I was lucky enough to be present for a rare showing of a few of the originals in the Unst Heritage Centre. Close inspection revealed that some items were knitted from beautifully prepared and finely spun yarn, while others used thicker, more uneven yarn. As was to be expected, the thick yarns were knitted into socks and gloves while the finest yarns were used for complex knitted shawls.

Some of the shawls had colored lace edgings. A close examination of the edgings reveals areas of slightly darker and lighter color, indicating that the lace had been dyed after it was knitted, then sewn on. The blue would have been dyed with indigo and the brown probably with tea. One piece, a roughly triangular shawl, had a thick cotton yarn threaded through each scallop of its lace edging to ready it for blocking. However, it hadn’t yet been blocked. Usually, several shawls would have been blocked at the same time. This one would have been sent unwashed to a designated laundress to join others of the same size to be blocked all together.

The story of how a fine knitted lace shawl was given to Queen Victoria, and how other Shetland shawls were taken to London for fashionable wear is well known. But in addition to the knitted pieces sent south, there was a knitting trade on the islands themselves.

The Shetland archipelago is long and thin, comprised of many small islands. For centuries, the main town has been Lerwick, situated on the east coast, roughly half way up the main island. Until recently, travel was by foot or by boat. People were used to walking many miles on tracks across the boggy, heather-clad hills, but travel by boat was often preferable. Folk living within about five miles of Lerwick tended to bring their knitted pieces into the town to sell them to the Lerwick shops or to the traders who would send the goods down south. But for folk living farther away, selling their knitting to local people was often a better bet.

Keep in mind that during the nineteenth century (and on into the twentieth), Shetland women were not usually knitting for pleasure; they were knitting for practical reasons. And the driving force behind fine Shetland lace knitting has always been economic.

Living on the islands was hard work. The weather conditions were harsh and relentless. The soil was thin and often impoverished, and many plants couldn't withstand the salt winds that hammer the islands. Although fish were plentiful, fishing was always a dangerous business. Weather could change in minutes, and storms could whip up out of blue skies. The peat that provided light and warmth had to be cut and dried on the hills, then brought down to the dwellings by foot or pony—all hard, physical work.

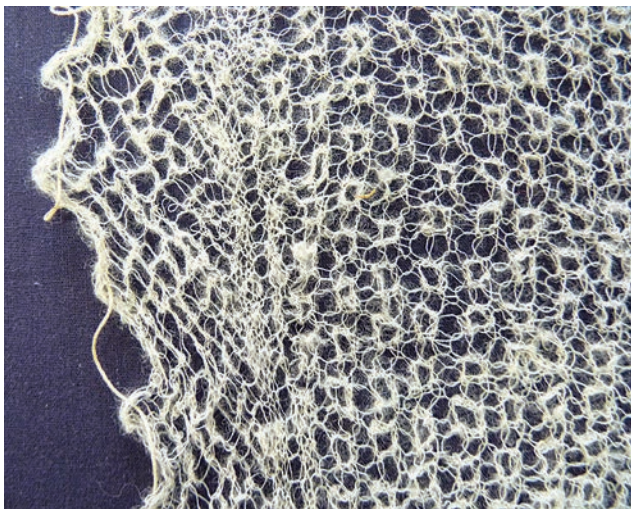

The triangular shawl with a thick cotton yarn threaded through each scallop of its lace edging in preparation for blocking.
Photograph by the author and courtesy of the Unst Heritage Centre, Unst, Shetland.

Under the islands' harsh conditions, the hardy Shetland sheep thrive. They have provided much for the islanders—milk, meat, wool, and hide. Like all old breeds, Shetland sheep have a variable fleece. The fineness of the fiber varies widely both between animals and on the same animal.

Unst Heritage Centre

Unst Heritage Centre is situated on Unst, the northernmost island in Shetland. Our collection reflects the island's crofting (farming) heritage, but the collection of handspun, handknit lace is particularly appreciated by visitors, especially knitters. This includes the rare lace knitwear referred to in the article. We welcome visitors on textile tours and we organize workshops in designing and knitting fine lace during the annual Shetland Wool Week. We have some knitting patterns unique to the Centre and are currently seeking funding to produce a booklet of lace motifs for the experienced knitter. www.unstheritage.com.

—Rhoda Hughson



Shetland lace display at the Unst Heritage Centre. Photography by Visit Scotland and courtesy of the Unst Heritage Centre, Unst, Shetland.

Although for today's needs, this variance might be a disadvantage, historically it was a great benefit. A flock would have sheep that provided fleece suitable for both tough outerwear and soft underwear. Blankets would be made from the coarser parts, and any fleece not capable of being spun would go into mattresses and pillows or on to the midden (rubbish heap), where it would give off heat as it decomposed, leaving a good compost to enrich the ground used for growing vegetables. Most flocks had one or two sheep whose fleeces were particularly fine. These were known as "kindly" sheep, and they were tethered near the back of the house so that no one could steal them. Their fleeces were used to spin the finest yarns to be knitted into the finest shawls.

Every young girl would be taught to knit and to spin, and by the time she had reached her early teens, it would be obvious where her talents lay. If she were a particularly talented spinner, a girl might be excused from some of the heavier farm work to spend her time spinning very fine yarn. The best knitter would then knit up the yarn, and the best bargainer would take finished pieces to the local shop to get as much money as possible for each item. Once a woman became known for producing quality items, whether fine lace or sturdy stockings, she would get orders from the slightly wealthier in the community. She could then knit items to order and not need to go through a middleman. The knitter would receive more money and the buyer would pay less, a system that suited both.

With no Social Security, National Health Service, or pensions, life for the old or infirm was harder still. Unmar-



Lace socks found in the box of knitted items along with James Moar's letter. Photograph by the author and courtesy of the Unst Heritage Centre, Unst, Shetland.

ried women, whatever their natural talent, often found that the only way they could support themselves was by spinning and knitting, hence the term "spinster" for an unmarried woman. If folk fell ill, knitting might well be the only way they could survive, as the letter from James Moar shows. Census records trace James Moar's knitting career. He is listed first as a knitter of hosiery, then later as a knitter of fine lace. He died in 1919 in Lerwick.

The treasures waiting in the box at Uyeasound have helped flesh out the story of the island's knitting trade. So the next time you're clearing out space or moving, make sure you open each box before you throw it away. One just might contain the kinds of treasures that can further our knowledge of times past. 🌿

Further Resources

- Fryer, Linda G. *Knitting by the Fireside and on the Hillside: History of the Shetland Hand Knitting Industry c. 1600-1900*. Lerwick, Scotland: The Shetland Times, 1994. Out of print.
- Laurenson, Sarah, ed. *Shetland Textiles 800 BC to the Present*. Edinburgh: Shetland Heritage Publications, 2013.

ABOUT THE AUTHOR AND DESIGNER. *Elizabeth Lovick lives on a small island off the top of Scotland, where she spins and knits, researches, and writes. She has a special interest in bringing traditional knitting styles to new audiences. Her website is www.northernlace.co.uk, and she blogs as Northern Lace. She is northernlace on Ravelry and Facebook and LizLovick on Twitter.*

A companion project follows



A Great Skua flying over moorland on Saxa Vord, Unst. There are no trees on the island as the salt winds are too strong for them to grow. Photograph by and courtesy of the author.

Uyeasound Table Runner

ELIZABETH LOVICK

Inspired by the preceding article

This design is based on one of the pieces found in the back of the Uyeasound shop in Unst, Shetland. The original piece has a separate, sewn-on lace edging dyed with indigo after the lace was knitted. The original piece is wider and shorter, probably designed to be used as a tray cloth. The yarn in the original is a two-ply handspun yarn, and the patterns are typical of Shetland lace in the 1890s.



Elizabeth Lovick's exquisite Uyeasound Table Runner inspired by a late-nineteenth-century piece of knitted lace intended for sale. The lace was found in a box in one of the Uyeasound post office buildings more than a century after it was knitted. Photograph by Joe Coca.

Materials

Jamieson & Smith Supreme Lace Weight, 100% Shetland wool yarn, 1 ply, laceweight, 436 yards (398.7 m)/25 gram (.88 oz) ball, 1 ball of White; www.shetlandwoolbrokers.co.uk

Needles, size 2 (2.75 mm) or size needed to obtain gauge; 1 needle, size 6 (4 mm) for CO and BO

Blocking wires, 2, at least 12 inches (30.5 cm), and 2, at least 30 inches (76.2 cm) long

Blocking pins

Finished size: 21 inches (53.3 cm) long and 10 inches (25.4 cm) wide, after blocking

Gauge: 32 sts and 56 rows = 4 inches (10.2 cm) in garter stitch on size 2 (2.75 mm) needles; 37 sts of center lace panel (from yo to yo) = 4½ inches (11.4 cm) wide on size 2 (2.75) needles

Instructions

Notes: See page 124 for Abbreviations and Techniques. One ball of yarn should make a runner up to 40 inches (101.6 cm) long. Only odd-numbered rows are charted. For all even-numbered rows, work yo, k2tog, k to end of row, except where there is a double yarnover on the row before, the first is knitted as usual and the second is purled. Work all single yarnovers and knit two together as knit one through the back loop.

Runner

Using larger needle and working loosely, CO 74 sts. Change to smaller needles.

Row 1: Yo, k2tog, k to end of row.

Rep last row 5 more times.

✿ By the Dexterous Use ✿ of Two Threads: Gloves and the Handknitting Industry of Sanquhar, Scotland

ANGHARAD THOMAS



High Street in the village of Sanquhar, 1860. Photograph courtesy of the Dumfries and Galloway Museums Service, Dumfries, Scotland.

On the gentle green slopes of southwest Scotland's Nith river valley sits the ancient town of Sanquhar—a crossroads that has drawn travelers and tradespeople for centuries. Rowan Reid, a local historian who has studied the history of Sanquhar knitting, describes the wool trade along Scotland's southern coast as having been an important one since medieval times. By the eighteenth century, Sanquhar had developed into a central wool-marketing town; the July Sanquhar Wool Fair determined wool prices for all of southern Scotland, though the fair's importance had begun to diminish by the end of the nineteenth century. Processing wool and making cloth employed many for multiple generations. From the eighteenth century on, knitting, including the production of socks and gloves, was counted among Sanquhar's industries. Though the town has just 2,000 or so inhabitants today, Sanquhar is still known in handknitting circles for the intricately patterned gloves that bear its name.

Sanquhar Duke pattern gloves in the collection of the Knitting & Crochet Guild, United Kingdom. The center pair, with the initials UW, were commissioned and knitted in Sanquhar. Photograph by the author, courtesy of the board of the Knitting & Crochet Guild, United Kingdom.



Establishing a history of this specialized knitting is difficult because it was very much a domestic activity, a true “cottage industry.” Also, because the knitting took place in the sorts of households where the earnings were welcome but where few accounts or inventories were kept, relatively few written records exist. Rowan Reid wrote, “Knitting was usually a means of supplementing the income of subsistence farmers; it is therefore elusive in contemporary accounts and records. The work of women and children, the sick and the aged often does not figure as a recognized trade.”

During the eighteenth century, handknitting as a domestic industry was widespread in the poor, rural uplands of Britain, including Scotland, Wales, and the Yorkshire Dales. Farming was subject to the vagaries of the weather, and other occupations, such as lead mining, were subject to fluctuations in demand. The need to supplement varying and meager incomes spurred these regions to become centers for the production of handknitted goods, which were produced by all members of the family in odd moments. At the core of the handknitting industry were stockings knitted in the round to be sold; stockings for the troops especially were in constant demand during times of war. The British colonies and the rapidly industrializing cities of the United Kingdom also were markets for the stockings. Evidence of and references to

the knitting and sale of Sanquhar gloves are few. Other textile industries left their mark: historical sources list the numbers of weaving looms in the area and give accounts of a carpet mill in a village close by; historical accounts mention knitting stockings. Though the 1912 records from Sanquhar’s churchyard list many people’s occupation as “weaver,” no graves record “knitter.” Nevertheless, a story can be pieced together through the gloves themselves, using fragments of documentation.

In the writings of local people more than 200 years ago, one can find hints that patterned knitting, probably stockings, existed. Stocking knitting started out as a home craft, but after the introduction of the stocking frame about 1770, it began to grow into an important industry throughout the Sanquhar region. Rowan Reid cites a description of the knitting industry from the 1770s: “Here are five frames in the stocking way, and a great deal of stockings knit and sold here, from one shilling to five shillings per pair, and a great demand for them.”

An account of Sanquhar in 1807 by local printer Thomas Brown, in the *Union Gazetteer for Great Britain and Ireland* (London: Vernor, Hood, and Sharpe) details the production of woven cloth, carpets, knitted stockings, and mitts. He writes that knitters “. . . by the dexterous use of two threads produce a substance resembling an outside and a lining. . . .” (The mitts mentioned would have most likely been fingerless, giving the hand protection while working.)

Author James Brown in *History of Sanquhar* (Edinburg: J. Anderson & Son, 1891) describes Sanquhar gloves and stockings in the early nineteenth century as “being woven on wires in a peculiar manner,” which presumably means knitted on fine needles. He goes on to say that this production could form the basis of a good industry for people in their own homes and that this would prevent the area from becoming depopulated. “But if this is to be

done, it must be done without delay, as the secret of the manufacture is now confined to a very few. It threatens to become a lost art.”

Despite economic changes, however, glove knitting in Sanquhar survived. In the late eighteenth century, several factors had begun to cause handknitting in much of Scotland to wane. Among those factors were the industrialization of spinning and processing wool and the inability to compete with the price of inexpensive machine-made garments. Yet the gloves themselves remained. Historical examples are found in the Knitting & Crochet Guild’s collection, the Tolbooth Museum in Sanquhar itself, and the Dumfries Museum, about 20 miles (32 km) away. Some are very worn and darned, and some are single gloves without a partner. The examples in the Knitting & Crochet Guild’s collection are all thought to have been bought in Sanquhar, having been commissioned with the personal initials of the original owner.

Sanquhar gloves are handknitted with tightly spun wool in two colors in a variety of detailed patterns, of which the Duke is the best known. Other patterns include Prince of Wales, Shepherd’s Plaid, Rose and Trellis, Drum and Cornet, Pheasant’s (or Bird’s) Eye, and one of the oldest, Midge and Flea. Black and white is the most common color combination.

One of the earliest pairs of patterned gloves still in existence is found in the Dumfries Museum from the collection of local historian Dr. Thomas B. Grierson, who died in 1889. He recorded them as “. . . of a pattern formerly worked at Sanquhar.” They are knitted in the Duke pattern and are well over one hundred years old. About 1880, the Duke of Buccleuch, the local landowner, placed an order for a large number of gloves, according to Richard Rutt in his *History of Hand Knitting*. Other re-



Blue Sanquhar gloves in the Duke pattern from the collection of Mrs M. E. MacDonald. They were made for sale in the 1950s and 1960s by Mrs. Aitken of Dumfries. Photograph courtesy of the Dumfries and Galloway Museums Service, Dumfries, Scotland.

ords from the end of the nineteenth century also suggest that gloves were being knitted in Sanquhar at that time.

Sanquhar gloves were known to have been on sale in shops in Edinburgh in 1900; the town clerk of Sanquhar reported seeing them there. No doubt he would have been proud to see this product of his town on sale in the Scottish capital.

After the First World War (1914–1918), it seems that gloves were knitted for personal orders. At a wool shop in Sanquhar, visitors could place orders for gloves with particular initials. Documents at the Tolbooth Museum in Sanquhar note that the knitter would receive two shillings and sixpence for a pair of gloves with personalized initials for which the customer provided the wool. That was in the 1920s and 1930s, when visitors came to the area for hunting and fishing, as they still do. The fortune of the Sanquhar glove was possibly secured by the return to Sanquhar of Miss Mary Forsyth (dates unknown), who came back to her native town in 1933 as a teacher of domestic science at Sanquhar Academy. From that time on, every girl knitted a pair of gloves when she was about thirteen or fourteen years old. Girls from a Glasgow school, who were evacuated to Sanquhar during World War II (1939–1945), also were taught to knit the gloves. This teaching established a knowledge and skill base that has helped ensure the continued existence of the glove knitting.

After World War II, glove knitting continued, mainly for visitors to the town. By this time, according to the displays in the Tolbooth Museum, two women, Jessie Wilson and her daughter were active knitters of



Gloves for sale in the local arts center, A' the Airts, in Sanquhar. Photograph by the author and courtesy of the A' the Airts director.

gloves and may have made a partial living from it. They were being paid five shillings for knitting a pair of gloves for which the customer provided the yarn. The patterns were passed on orally until 1955, when the first patterns were published in a woman's weekly magazine, *The People's Friend*. The pattern for a Sanquhar glove and scarf set was first published as a free supplement in *The Scottish Knitting Book No 1*. Later that same year, 1955, *The People's Friend* published *The Sanquhar Knitting Book*, which included similar Sanquhar patterns.

In his *History of Handknitting*, Rutt wrote of Mrs. Thomson, wife of the parish minister, who was "using the Sanquhar fabrics for fully-fashioned hand-framed garments." The same Mrs. Thomson, now in her late seventies, is still actively working on the production and continuation of Sanquhar knitting. She has written two instruction manuals for Sanquhar gloves and Sanquhar socks, available as kits through the A' the Airts, Upper Nithsdale's Community Arts and Crafts Centre. Gloves can be commissioned or bought at this center along with other items featuring the Duke pattern (www.all-the-airts.com).

The tradition of knitting gloves continues. A Sanquhar knitting group communicates on *Ravelry*, and the written patterns have been re-issued by the Scottish Rural Women's Institute. Handknitted gloves, along with other related Sanquhar-patterned items, such as greeting cards and key rings, provide an income in the twenty-first century. ❁

Green Sanquhar gloves in the Duke pattern from the collection of Mrs M. E. MacDonald. They were made for sale in the 1950s and 1960s by Mrs. Aitken of Dumfries. Photograph courtesy of the Dumfries and Galloway Museums Service, Dumfries, Scotland.



Sanquhar gloves in the Duke pattern

These gloves are from the collection of Dr Thomas B Grierson, who died in 1889. He recorded them as "of a pattern formerly worked at Sanquhar". They are therefore well over 100 years old.

Sanquhar gloves knitted in the Duke pattern, originally from Dr. Thomas B. Grierson's collection, now in the collection of the Dumfries Museum, Dumfries, Scotland. Photograph by the author, courtesy of Dumfries Museum, Dumfries, Scotland.

ABOUT THE AUTHOR AND DESIGNER. *Dr. Angharad Thomas is an independent designer, maker, and researcher. She is also the textile archivist for the collection of the Knitting & Crochet Guild of the United Kingdom. She has worked as a teacher, knitwear designer, and university lecturer. In the course of her career, she has travelled to Europe, the United States, Japan, Africa, and Australia. When not knitting or writing, she's often hiking and trekking in Britain and the Pyrenees. The author thanks all those in Sanquhar who helped with the research for this article and project, including the Dumfries Museum. She also thanks the board of the Knitting & Crochet Guild for permission to use the guild's photographs, and colleagues in the guild for their feedback.*

Further Resources

- Reid, Rowan. *Traditional Scottish Knitting: Sanquhar Pattern Gloves History and Knitting Pattern*. N.p.: The Galloway Tryst, 1998. Out of print.
- Rutt, Richard. *A History of Hand Knitting*. 1987. 2nd ed. Loveland, Colorado: Interweave, 2003.
- www.futuremuseum.co.uk/collections/life-work/key-industries/textiles/sanquhar-knitting.aspx

A companion project follows

Prince of Wales Sanquhar Gloves

ANGHARAD THOMAS

Inspired by the preceding article

Angharad Thomas's gloves in the Prince of Wales pattern create the pleasingly crisp geometric design for which Sanquhar knitting is famous. Photograph by Joe Coca.



The Prince of Wales, Albert Edward (1841–1910), the heir to the throne, visited Sanquhar in 1871, and the pattern or its name possibly dates from then. The glove has all the elements of the Sanquhar glove—two-color rib, a band with initials and date around the cuff, and the patterned hand and fingers. The thumb on this pair is placed at the side of the hand; the glove may be worn on either hand to even the wear.

The initials and date may be modified or omitted, if preferred. The gloves have a plain alphabet, seven stitches high. For a more vintage look, choose one that has serifs on the letters. Chart out your chosen letters and dates before knitting and depending on their length, the size of the panel may be altered. The row above and below the initials or date is the only place where the second yarn has to be caught under the first to avoid a long thread on the back of the work.

Materials

Schachenmayr Regia 3-Ply, 75% wool/25% polyamide yarn, fingering weight, 284 yards (259.7 m)/50 gram (1.8 oz) ball, 1 ball each of #324 Marine (MC; dark blue) and #1970 Pigeon Blue (CC; light blue); www.westminsterfibers.com

Needles, set of double pointed or 2 circulars, size 1 (2.25 mm) or size needed to obtain gauge

Stitch holders

Markers

Tapestry needle

Finished size: 7½ inches (19.0 cm) in circumference

Gauge: 45 sts and 44 rnds = 4 inches (10.2 cm) in charted patt

The pattern on the hand is easy to knit and to memorize. There are two rows of alternate stitches followed by two rows of three dark, three light. Depending on how these fall, dark or light diamonds are formed. The fingers and thumb alternate dark and light stitches.

The gloves may be knitted using four or five double-pointed or two circular needles. Two circulars is now my preferred method as it allows the front and back of the hand stitches to have a separate needle each. The stitch that runs up the side of the hand is at the start of each needle and allows a neat change of round. The “jog” in the pattern is disguised by this vertical stitch.

The colored rib and patterned hand and fingers are hallmarks of Sanquhar glove patterns.
Photograph by Joe Coca.



Instructions

Notes: See page 124 for Abbreviations and Techniques. Tuck each finger into glove after it is completed to keep it out of the way.

Right Glove

With MC and using the long-tail method, CO 80 sts. Pm and join to work in the rnd. K 1 rnd.

Next Rnd: K2 with MC, *p2 with CC, k3 with MC; rep from * to last 3 sts, p2 with CC, k1 with MC.

Rep last rnd 19 more times.

With MC, k 2 rnds.

Work Rows 1–40 of Right Glove Chart, pm for gusset as shown on Row 12 of chart—110 sts.

Next Rnd (Row 41 of Chart): Work to m, remove m, place next 29 sts on holder for thumb, remove m, CO 4 sts as shown on chart, work in patt to end—85 sts rem.

Cont in patt through Row 57 of chart.

Fingers,

Notes: Fingers and thumb are worked in Salt and Pepper pattern, alternating main color and contrasting color stitches. You *may* have to knit two together or pick up an extra stitch when starting the fingers to maintain this pattern correctly, but ensure that you have an odd number of stitches for each finger.

Index finger,

Sl 1st 14 sts of rnd (palm side of hand) onto a dpn, and last 10 sts of rnd (back of hand with date) onto a separate dpn; place rem 61 sts on holder.

Keeping in Salt and Pepper patt, work 14 palm sts, CO 3 sts, then work 10 sts from back of hand—27 sts total.

Work in patt for 2¼ inches (5.7 cm) or to desired length.

Shape top of finger,

Alternating MC and CC, k3tog around—9 sts rem. Break yarn, leaving an 8-inch (20.3-cm) tail. Thread tail on the tapestry needle, draw through rem sts, pull tight to gather, and fasten off on WS.

Middle finger,

Sl next 10 sts of rnd (palm side of hand) onto a dpn, and last 10 sts (back of hand with date) onto a separate dpn.

Keeping in Salt and Pepper patt, work 10 palm sts, CO 3 sts, work 10 sts from back of hand, pick up and k 4 sts from base of index finger—27 sts total.

Work in patt for 2¾ inches (7.0 cm) or to desired length.

Shape top of finger and finish as for index finger.

Ring finger,

Work as for middle finger.

Little finger,

Sl rem 21 sts onto dpn. Keeping in Salt and Pepper patt, work 21 sts, pick up and k 2 sts from base of 3rd finger—23 sts total.

Work in patt for 1¾ inches (4.4 cm), or to desired length.

Shape top of finger,

[K3tog] 7 times, k2tog—8 sts rem. Finish as for index finger.

Thumb,

Sl 29 thumb sts onto dpn. Keeping in Salt and Pepper patt, work 29 sts, pick up and k 4 sts from CO above thumb—33 sts total.

Work in patt for 1¾ inches (4.4 cm) or to desired length.

Shape top of thumb as for index finger—11 sts rem. Finish as for index finger.

Left Glove

Work as right glove, working Left Glove Chart in place of Right Glove Chart.

Index finger,

Sl 1st 10 sts of rnd (back of hand with initials) onto a dpn, and last 14 sts of rnd (palm side of hand) onto a

Right Glove

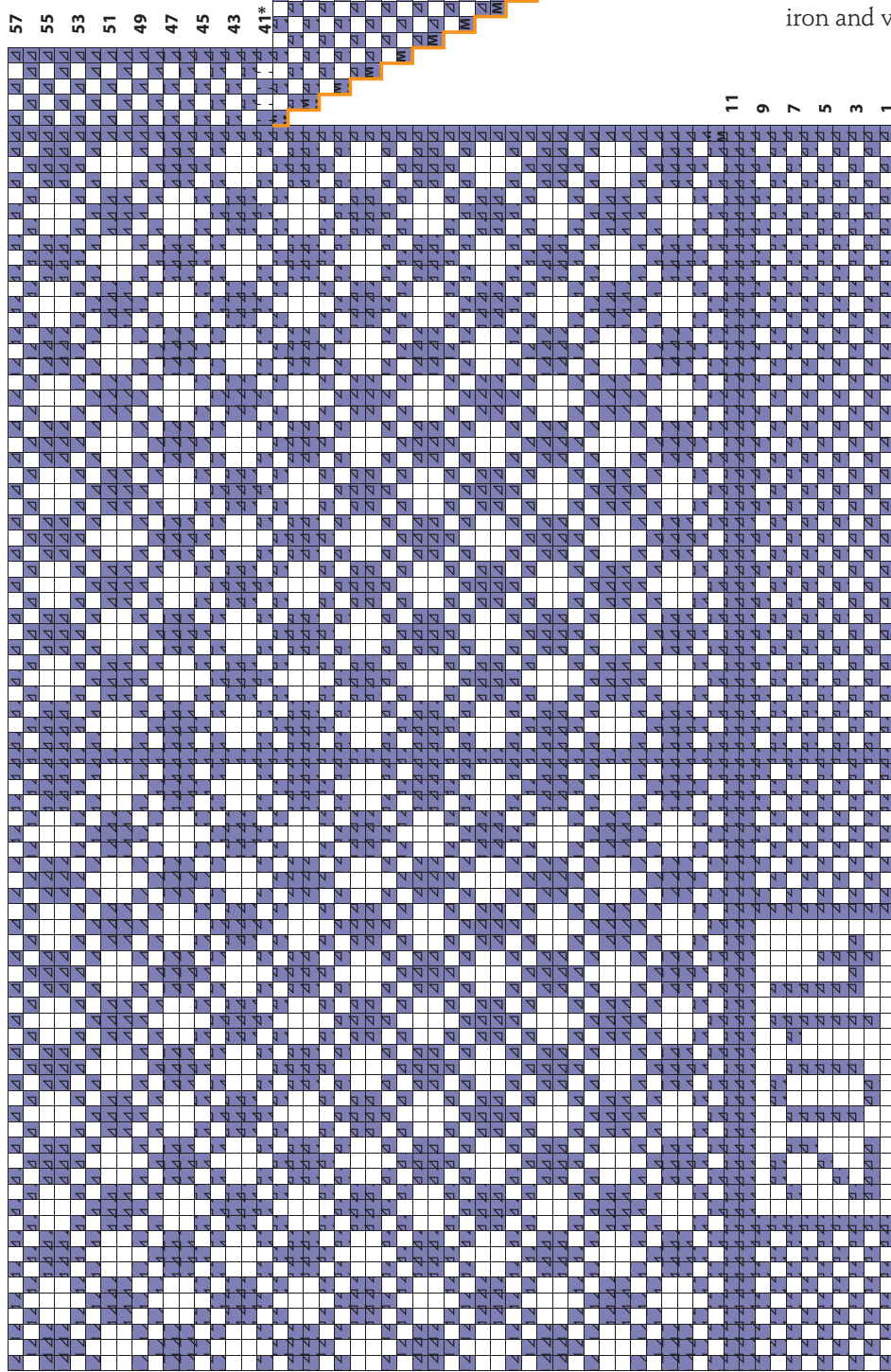

*Work as given in directions

80 sts to 110 sts to 85 sts

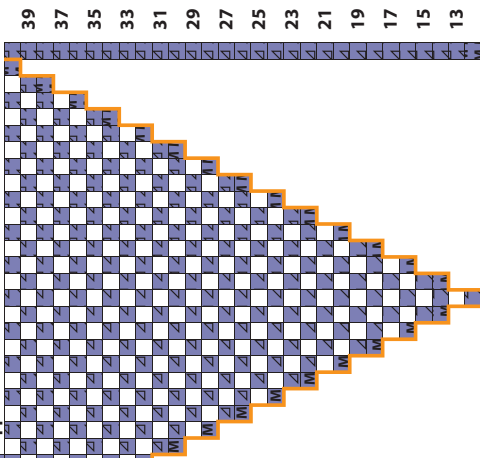





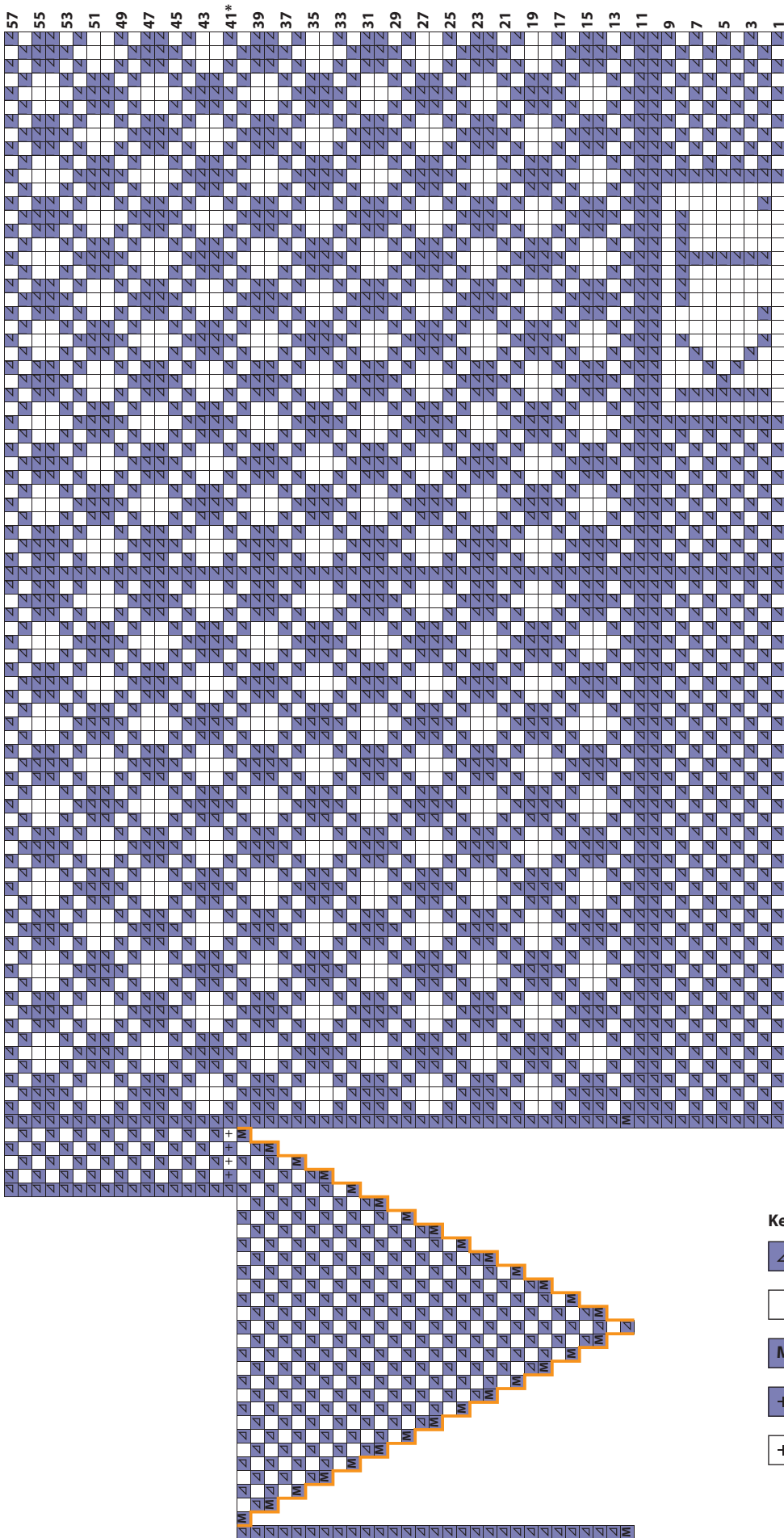

separate dpn; place rem 61 sts on holder. Keeping in Salt and Pepper patt, work 10 back of hand sts, CO 3 sts, then work 14 sts from palm—27 sts total. Work and finish as for right index finger, middle finger, ring finger, little finger, and thumb.

Finishing

Weave in loose ends, closing gaps at base of fingers where necessary. Press lightly using a hot iron and wet cotton or linen cloth. ❁

Left Glove



- Key**
-  k with MC
 -  k with CC
 -  M1 with MC, picking up MC strand
 -  CO 1 st with MC
 -  CO 1 st with CC
 -  gusset m

*Work as given in directions

80 sts to 110 sts to 85 sts

Charts may be photocopied for personal use.

The charts for this project are available in PDF format at pieceworkmagazine.com/Charts-Illustrations.

Winter: A Sanquhar Glove Pattern

BETH BROWN-REINSEL



Pine trees and snowflakes grace Beth Brown Reinsel's Winter gloves, her personalized variation of the classic Sanquhar pattern.
Photograph by Joe Coca.

I have been fascinated by the lovely Scottish tradition of Sanquhar gloves since I first saw a photograph of them. Drawn to their apparent complexity, I was happily surprised at the simple logic of their construction. Due to their fixed layout, these gloves are best knitted in different sizes by changing the needle and yarn size. I could not resist playing with the squares, while leaving the basic architecture alone. Now that I live in Vermont and winter is always around the corner, I chose little pine trees and snowflakes to grace my gloves that will keep me warm in beautiful, but frigid, New England.

Materials

Upton Yarns Cotswold x Romney, 100% wool yarn, fingering weight, 105 yards (96.0 m)/25 gram (.88 oz.) skein, 2 (2, 3) skeins of Pine Green (MC) and 2 skeins of Natural (CC); www.uptonyarns.com
Needles, set of double pointed, size 00 (0, 1) [1.75 (2, 2.25) mm] or size needed to obtain gauge

Markers

Stitch holders

Tapestry needle

Finished size: 7¼ (7¾, 8) inches (18.4 [19.7, 20.3] cm) in circumference

Gauge: 46 (44, 40) sts and 46 (44, 40) rnds = 4 inches (10.2 cm) in charted patt

Special Technique

Cast on in Pattern: Using the long-tail method and working yarns, holding color for stitch over index finger and other color over thumb, cast on the number of stitches needed in that color, swap yarns by bringing index finger yarn over thumb yarn, then cast on the number of stitches needed in new index finger color; repeat as needed.

Instructions

Notes: See above and page 124 for Abbreviations and Techniques. On bands with an odd number of motifs, the beginning and end of round will have the same motif. Motifs alternate vertically: snowflake over tree and tree over snowflake.

Gloves

Corrugated Rib,

With MC and using the long-tail method, CO 78 sts.
Pm and join to work in the rnd.

K 6 rnds.

Work Row 1 of Corrugated Rib Chart, then rep Rows 2 and 3 nine times, or to desired length.

K 2 rnds with MC.

Salt and Pepper Cuff,

Work 11 rnds foll Salt and Pepper Chart only, or include initial and date boxes as foll. *Note:* Initial and date boxes were typically worked on the palm side, but you may work them on the back of hand side if desired.

Initials Left Glove,

To place initial box on back of hand, work Salt and Pepper Chart over 17 sts, work 15 sts of Initial Chart, work Salt and Pepper Chart over 46 sts.

To place initial box on palm, work Salt and Pepper Chart over 58 sts, work 15 sts of Initial Chart, work Salt and Pepper Chart over 5 sts.

Date Right Glove,

To place date box on back of hand, work Salt and Pep-

per Chart over 44 sts, work 19 sts of Date Chart, work Salt and Pepper Chart over 15 sts.

To place date box on palm, work Salt and Pepper Chart over 3 sts, work 19 sts of Date Chart, work Salt and Pepper Chart over 56 sts.

Both Gloves,

Cont in patt through Row 11 of Initial Chart.

Hand,

1st horizontal band,

K 1 rnd with MC, inc 1 st—79 sts.

Left glove,

Work Gusset Chart, pm, *work Snowflake Chart, work Tree Chart; rep from * 2 more times, work Snowflake Chart.

Right glove,

*Work Snowflake Chart, work Tree Chart; rep from * 2 more times, work Snowflake Chart, pm, work Gusset Chart.

Both gloves,

Cont in patt through Row 11 of charts—98 sts.

2nd horizontal band left glove,

Work Tree Chart over 10 sts, M1R with MC (counts as last st of chart), *work Snowflake Chart, work Tree Chart; rep from * 3 more times—99 sts.

Right glove,

*Work Tree Chart, work Snowflake Chart; rep from * 2 more times, work Tree Chart, work Snowflake Chart over 10 sts, M1R with MC (counts as last st of chart), work Tree Chart—99 sts.

Both gloves,

Cont in patt through Row 11 of charts.

3rd horizontal band,

*Work Snowflake Chart, work Tree Chart; rep from * 3 more times, work Snowflake Chart.

Cont in patt through Row 5 of charts.

Left glove,

Next Rnd (Row 6 of Charts): Place 22 thumb sts on holder, CO 11 sts in Tree patt, work in patt to end—88 sts rem.

Right glove,

Next Rnd (Row 6 of Charts): Work in patt to last 22 sts, place 22 thumb sts on holder, CO 11 sts in Tree patt—88 sts rem.

Both gloves,

Cont in patt through Row 11 of charts.

4th horizontal band left glove,

*Work Snowflake Chart, work Tree Chart; rep from * 3 more times.

Upton Yarns

Upton Yarns is a small yarn business in Maine. Sarah Lake begins with selecting fleeces and specifying her exacting standards for her different yarns to the mill. When the yarns are returned to her, she uses vegetal dyes from indigo to madder and more to create her rich palette. I love this Cotswold x Romney, created for fine colorwork as used in Sanquhar gloves, in particular because it is highly twisted, and it is a three ply. This means it will be very warm and structurally sound, enduring for a long time.

B. B.-R.



Traditional Sanquhar ribbing and Salt and Pepper patterning trim Beth Brown Reinsel's Winter gloves. Photograph by Joe Coca.

Right glove,

*Work Tree Chart, work Snowflake Chart; rep from * 3 more times.

Both gloves,

Cont in patt through Row 11 of charts.

Fingers and Thumb

Left glove,

Sl 1st 22 sts onto dpn for index finger.

Right glove,

Sl last 22 sts of rnd onto dpn for index finger.

Both gloves,

Place next 11 sts of palm and 11 sts of back of hand on holders for middle finger. Place next 11 sts of palm and 11 sts of back of hand on holders for ring finger and rem 22 sts on holder for little finger.

Note: When picking up stitches for the middle and ring fingers, you may pick up extra stitches with the main color to avoid a gap between needles, then decrease them away in the first few rounds. If a finger is too long or short, remove or add motifs as needed; if a full motif would add too much length, work Salt and Pepper Chart to needed length. For ease of knitting, push completed fingers down into the hand out of the way.

Left index finger,

With yarns attached at end of rnd, work Tree Chart, then Snowflake Chart, then CO 11 sts for inner edge of finger—33 sts.

Right index finger,

With yarns attached at beg of rnd, CO 11 sts for inner edge of finger, then work Snowflake Chart, then Tree Chart—33 sts.

Both index fingers,

Cont in patt, working a Snowflake, a Tree, or Salt and Pepper over CO sts. Work a total of 3 horizontal bands,

alternating motifs on each band as established. With MC, k 1 rnd.

Shape tip,

Note: Be certain the stitches are distributed so that one motif (eleven stitches) is on each of three needles.

Dec Rnd: *Ssk with MC, work in Salt and Pepper to last 2 sts of needle, k2tog with MC; rep from * 2 more times—6 sts dec'd.

Rep Dec Rnd every rnd 3 more times—9 sts rem.

Next Rnd: With MC, [sssk] 3 times—3 sts rem. Break yarns and pull both through rem sts. Fasten off on WS.

Thumb,

Work 22 held thumb sts in patt (Row 6 of charts), then pick up and k 11 sts along CO edge foll Row 6 of Tree Chart—33 sts. Cont in patt through Row 11 of charts, then work 1 more horizontal band, alternating motifs as established. With MC, k 1 rnd. Work in Salt and Pepper to desired length. Shape tip as for index finger.

Middle finger,

Note: This finger has a tiny gusset worked between the index finger and the middle finger.

Place held sts onto 2 dpn. Join MC to motif on palm side (left glove) or back of hand side (right glove).

Next Rnd: With MC, k11, with a new dpn, pick up and k 11 sts along CO sts of inner edge of index finger, with a new dpn, k11, using the long-tail method, CO 11 sts—44 sts.

Beg with Row 2 of charts, cont as foll,

Dec Rnd: Work 11 sts in patt, ssk with MC, work in Salt and Pepper to last 2 sts of needle, k2tog with MC, work 22 sts in patt—2 sts dec'd.

Rep Dec Rnd every rnd 3 more times—36 sts rem; 3 sts rem for gusset.

Next Rnd: Work 11 sts in patt, ssk with MC, work in patt to end—34 sts rem; 1 st rem for gusset.

Next Rnd: Work 11 sts in patt, ssk (gusset st with 1st st of next motif), work in patt to end—33 sts rem.

Work a total of 3 horizontal bands. Shape tip as for index finger.

Ring finger,

Work as for middle finger, picking up sts along CO edge of middle finger instead of index finger.

Little finger,

Place held sts onto 2 dpn. Join MC to back of hand side (left glove) or palm side (right glove).

Next Rnd: K22, then pick up and k 11 sts between ring finger and little finger—33 sts.

Beg with Row 2 of charts, work 2 horizontal bands of motifs, alternating motifs as established. Shape tip as for index finger.

Finishing

Weave in loose ends. Handwash in warm water with soap designed for woolens. Rinse well. Gently squeeze out water by rolling in a towel and pressing water out. Lay flat to dry. The gloves will be more flexible and easier to put on after washing.

ABOUT THE DESIGNER. Beth Brown-Reinsel has been designing traditional knitting patterns and teaching workshops for over twenty years both here and abroad. She published *Knitting Ganseys* (Loveland, Colorado: Interweave, 1993) and has produced a new DVD, *Sanquhar Gloves: Knit a Scottish Tradition* (Loveland, Colorado: Interweave, 2014). Visit her website at www.knittingtraditions.com.

Initial

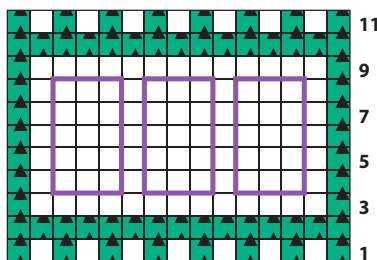

15 sts

Date

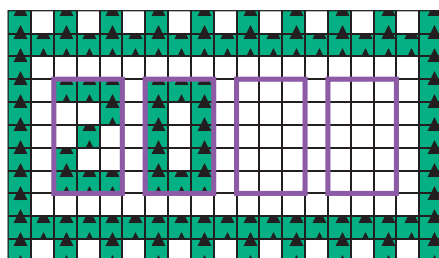

19 sts

Gusset

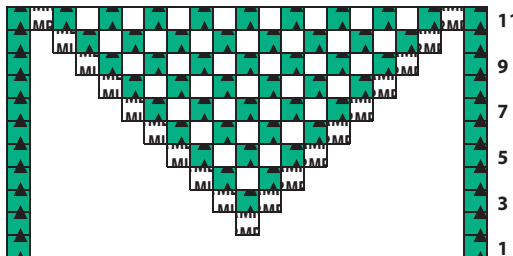

2 sts to 21 sts

Snowflake

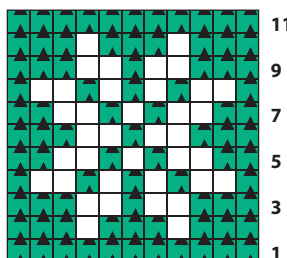





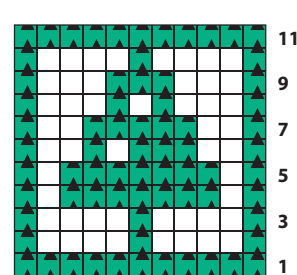

11 sts

Tree



11 sts

Key

-  k with MC
-  k with CC
-  p with CC
-  M1R with CC
-  M1L with CC
-  patt rep
-  letter or number placement

Corrugated Rib

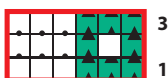

6-st rep

Salt and Pepper



2-st rep

Letters and Numerals

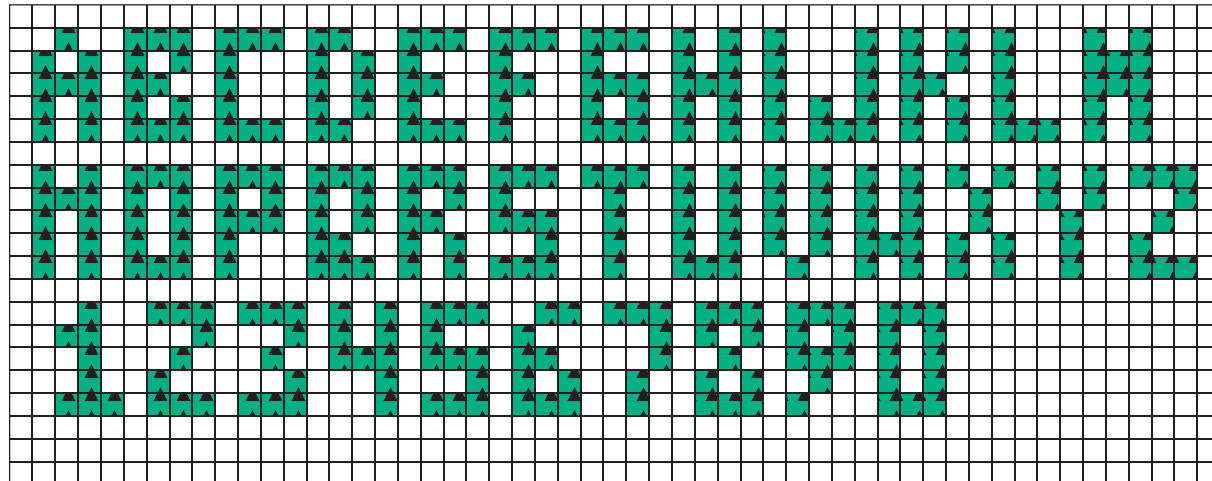

Charts may be photocopied for personal use.

The charts for this project are available in PDF format at pieceworkmagazine.com/Charts-Illustrations.

✿ Knitting Stockings in Wales ✿

S. MINWEL TIBBOTT

S Minwel Tibbott (unknown–1998) spent the years 1974 to 1995 researching traditional domestic life in Wales and published a series of articles in a variety of journals over the course of that time. Her research gave her an understanding of everything from cheese making to knitting stockings. The articles were gathered together and published in a single volume, *Domestic Life in Wales* (Cardiff, Wales: University of Wales, 2002). Portions of Tibbot’s chapter “Knitting Stockings in Wales: A Domestic Craft” are excerpted below with kind permission from the University of Wales.

—Editor

Knitting stockings had developed as a cottage industry in the highland districts of Wales by the eighteenth and nineteenth centuries, and was prevalent in the areas around specific market towns. Writing of the woollen industry in north Wales in the eighteenth century, historians have noted Llanrwst (Denbighshire) and Bala (Merioneth) as important centers for the stocking trade.

Tregaron, a market town in Cardiganshire, was the hub of the knitting industry in the counties of south-west Wales at the same period and it was reported that there were as many as 176 hosiers in the sub-district of Tregaron as late as the year 1851. There is ample evidence to prove that this cottage industry continued to be essential to the economy of many families well into the late nineteenth and early twentieth centuries.

It has been recorded that Welsh cattle-drovers of the eighteenth century took stockings with them to sell in English market towns. It has also been reported that the knitters of Trawsfnydd, Merioneth, frequently congre-

gated on the route of the stagecoach offering their stockings for sale to travellers. . . but the general pattern in the nineteenth century was to take them to sell at the local market or fair.

In the counties of north Wales, the two most notable stocking fairs were those held weekly in Llanrwst and Bala. Of Llanrwst market, it was reported by R. Fenton (1814) that £300 worth of stockings were sold in the morning before the market began by the knitters themselves. Elizabeth Williams in her autobiography *Siaced Fraith* remembers her own grandmother at the beginning of the twentieth century attending this fair every week to sell her stockings to the stocking man.

However, Bala was the most important centre for the stocking trade in the counties of north Wales in the eighteenth and nineteenth centuries. In 1748, the weekly value of the stockings sold was £200 and the sale of knitted articles at Bala accounted for one-fifth (£10,000) of the estimated woollen manufactures of Merioneth. The

WELSH CHARACTER SKETCHES.



"The Stocking Dealer. Stout-limbed, gaunt, hardest of the hardy, is the stocking man. He is a wanderer by nature and necessity, and a walker. . . . He is a child of the mountains, a part of them, as much as the shepherd and the sheep dog, and the whitewashed farm. . . . He is known to all the farmers. He is one of the few gossips who bring the news of world, and retail it in the long and sometimes difficult processes of trade. . . ." From "Welsh Character Sketches" in *The Red Dragon: The National Magazine of Wales*, Volume 11, August–December 1882 (Cardiff, Wales: Daniel, Owen, Howell and Company, 1882).

industry grew in importance later in the century. [Thomas] Pennant estimated the weekly value of the sales at Bala as £500 in 1780, while at the turn of the century it was estimated that 200,000 pairs of stockings (worth £18,000) were disposed of in one year—selling at an average price of between a 1s. 4 d. and five shillings a pair, and children's socks at eightpence a pair. The industry continued to thrive during the early part of the nineteenth century. By 1830, 32,000 dozen pairs of knit worsted stockings were sold annually in Bala, 10,000 dozen

pairs of socks, and 5,500 pairs of woollen gloves. The decline of the industry came later in the century with the competition from factory-made hose from the English Midlands which was facilitated by the advent of the railway. In the 1851 census, only 105 people in north Wales described themselves as "knitters" and another 148 as "stocking manufacturers." ❀

A companion project follows

Welsh Socks with a Quirk

JUDY ALEXANDER

Inspired by the preceding article

I was inspired to design the Welsh socks after reading S. Minwel Tibbott's "Knitting Stockings in Wales: A Domestic Craft," which described knitted socks from the Cardiganshire area of Wales. According to Tibbott, Welsh socks traditionally were knitted using two colors, a natural white for the toes and cuffs and a blue-gray yarn for the leg and foot. The socks were either knit in an all-over rib pattern or with decorative patterning on the sides referred to as a "quirk" or "clocks." She explains that when taking an order, a sock knitter would often ask, "What kind of quirk would you like on your stockings?" This design is my interpretation of S. Minwel Tibbott's description.

Instructions

Note: See pages 48 and 124 for Abbreviations and Techniques.

Socks

With CC, CO 63 (72) and divide evenly onto 4 dpn. Pm and join for working in the rnd, being careful not to twist sts.

Cuff,

Work Rnds 1 and 2 of Cuff Chart, working the 9-st patt rep 7 (8) times in each rnd, until cuff measures 1½ inches (3.8 cm) or desired length. End with Rnd 1. Break CC and change to MC.

Leg,

Small size only,

Inc 1 st on the 1st rnd of St st—64 sts.

Both sizes,

Work in St st until leg measures 4 inches (10.2 cm) or desired length to top of clock.

Right sock only,

Rnd 1: K7 (9), work Rnd 1 of Clock Chart, k to end of rnd.

Left sock only,

Rnd 1: K39 (45), work Rnd 1 of Clock Chart, k to end of rnd.

Both socks,

Work Rnds 2–26 of Clock Chart once, keeping sts before and after chart in St st—65 (73) sts.

Then rep Rnds 25 and 26 of Clock Chart, ending with Rnd 26, until leg measures 6¾ inches (17.1 cm) or desired length to top of heel flap.

Right sock only heel,

The heel is worked back and forth over 33 (37) sts.



Judy Alexander designed her socks after the Welsh tradition of using two colors, a natural white for the toes and cuffs and a blue-gray yarn for the leg and foot. A natural white color likely was used for the toe because the oil or lanolin in the fiber would have provided additional warmth to the sock wearer. Photograph by Joe Coca.

Materials

Cascade 220 100% wool yarn, fingering weight, 273 yards (249.6 m)/50 gram (1.8 oz) skein, 2 skeins of #9332 Sapphire (MC) and 1 skein #8010 Natural (CC); www.cascadeyarns.com
Needles, set of 5 double pointed, size 0 (2.0 mm) or size needed to obtain gauge

Finished sizes: 7½ (8½) inches (19.0 [21.6] cm) foot circumference
Gauge: 17 sts and 22 rows = 2 inches (5.1 cm) in St st in the rnd

Special Abbreviations

Right Twist (RT)—Skip the first stitch, knit into second stitch on the left needle, knit first stitch, then slip both stitches off the left needle

Left Twist (LT)—Skip first stitch on left needle, knit second, knit first stitch

Make One Purl (MP)—Lift strand between the last stitch worked and next stitch and place over left needle, purl into the back

Heel flap,

Set-Up Row (RS): K13 (15), p1, RT, p1, turn.

Row 1 (WS): Sl 1, p2, k1, p29 (33).

Row 2: Sl 1, k28 (32), p1, RT, p1.

Rep Rows 1 and 2, ending with Row 1, until heel flap measures 2 (2¼) inches (5.1 [5.7] cm) or desired length.

Turn heel,

Row 1 (RS): Sl 1, k21 (24), ssk, turn.

Row 2: Sl 1, p11 (13), p2tog, turn.

Row 3: Sl 1, k11 (13), ssk, turn.

Rep Rows 2 and 3 until all sts have been used—13 (15) sts rem.

Gusset,

Set-Up (RS): K6 (7) for new beg of rnd at center of heel.

Needles 1 and 4 contain the bottom of the foot and gusset sts, Needles 2 and 3 contain the instep sts.

Rnd 1: Needle 1, k7 (8), pick up and k tbl 1 st in each of the sl-st chains along side of heel flap; Needle 2, pick up and p tbl 1 st in gap between heel flap and instep sts, LT, p1, k to end of needle; Needle 3, k to end; Needle 4, pick up and k tbl 1 st in gap between heel flap and instep sts, pick up and k tbl 1 st in each of the sl-st chains along side of heel flap, k6 (7).

Rnd 2: Needle 1, k; Needle 2, work Rnd 1 of Right Foot Chart, k to end; Needles 3 and 4, k.

Dec Rnd: Needle 1, k to last 3 sts, k2tog, k1; Needle 2, work next rnd of Right Foot Chart, k to end; Needle

3, k; Needle 4, k1, ssk, k to end—2 sts dec'd.

Cont in patt as established and rep Dec Rnd every 3rd rnd until 65 (73) sts rem.

Foot,

Cont rep Rnds 1 and 2 of Right Foot Chart and keep rest of foot in St st until foot measures 2¼ inches (5.7 cm) less than desired foot length. Break off MC and join CC.

Left sock only heel,

The heel is worked back and forth over 33 (37) sts.

Heel flap,

Set-Up Row (RS): K16 (18), turn.

Row 1 (WS): Sl 1, p28 (32), k1, p2, k1, turn.

Row 2: Sl 1, LT, p1, k to end.

Turn heel,

Row 1 (RS): Sl 1, k21 (24), ssk, turn.

Row 2: Sl 1, p11 (13), p2tog, turn.

Row 3: Sl 1, k11 (13), ssk, turn.

Rep Rows 2 and 3 until all sts have been used—13 (15) sts rem.

Gusset,

Set-Up (RS): K6 (7) for new beg of rnd at center of heel.

Needles 1 and 4 contain the bottom of the foot and gusset sts, Needles 2 and 3 contain the instep sts.

Rnd 1: Needle 1, k7 (8), pick up and k tbl 1 st in each of



A delightful "quirk," in Judy Alexander's *Welsh Socks with a Quirk*. Photograph by Joe Coca.

the sl-st chains along side of heel flap, pick up and k tbl 1 st between heel flap and instep sts; Needle 2, k to end; Needle 3, k to last 3 sts, p1, LT, pick up and p tbl 1 st in gap between heel flap and instep sts; Needle 4, pick up and k tbl 1 st in each of the sl-st chains along side of heel flap, k 6 (7).

Rnd 2: Needle 1, k; Needle 2, k to last 4 sts, work Rnd 1 of Left Foot Chart; Needles 3 and 4, k.

Dec Rnd: Needle 1, k to last 3 sts, k2tog, k1; Needle 2, k to last 4 sts, work next rnd of Left Foot Chart; Needle 3, k; Needle 4, k1, ssk, k to end—2 sts dec'd.

Cont in patt as established and rep Dec Rnd every 3rd rnd until 65 (73) sts rem.

Foot,

Cont rep Rnds 1 and 2 of Left Foot Chart and keep rest of foot in St st until foot measures 2¼ inches (5.7 cm) less than desired foot length. Break off MC and join CC.

Toe, both socks,

K 1 rnd, dec 1 st at end of rnd—64 (72) sts rem.

Dec Rnd: Needle 1, k to last 3 sts, k2tog, k1; Needle 2, k1, ssk, k to end; Needle 3, k to last 3 sts, k2tog, k1; Needle 4, k1, ssk, k to end—4 sts dec'd.

K 3 rnds, [work Dec Rnd, k 2 rnds] 2 times, [work Dec Rnd, k 1 rnd] 3 times, then rep Dec Rnd until 8 sts rem.

Finishing

Graft stitches together from side to side using Kitchener Stitch, so a “band” of stitches forms across the top of the toe. Weave in ends. ❁

ABOUT THE DESIGNER. *Judy Alexander's passion is knitting and she loves being surrounded by yarn in all colors and textures. She lives in Longmont, Colorado, with her husband, two cats, and new puppy.*

Charts may be photocopied for personal use.

The charts for this project are available in PDF format at pieceworkmagazine.com/Charts-Illustrations.

Clock

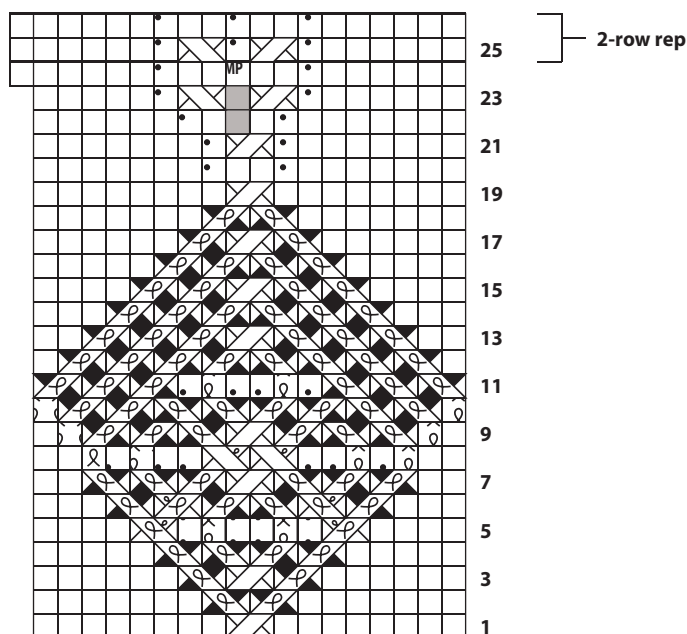

18 to 19 sts

Right Foot

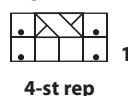



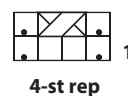









Left Foot



Cuff



Key

-  k
-  p
-  k1 tbl
-  M1 pwise
-  no st
-  patt rep
-  sl 1 st onto cn, hold in back, k1, k1 from cn (RT)
-  sl 1 st onto cn, hold in front, k1, k1 from cn (LT)
-  sl 1 st onto cn, hold in front, k1 tbl, k1 from cn
-  sl 1 st onto cn, hold in front, k1 tbl, k1 tbl from cn
-  sl 1 st onto cn, hold in back, k1 tbl, k1 tbl from cn
-  sl 1 st onto cn, hold in back, k1 tbl, p1 from cn
-  sl 1 st onto cn, hold in front, p1, k1 tbl from cn

✿ Teaching the Poor to Knit: ✿ Knitting Teachers in England from the Sixteenth to the Nineteenth Century

LESLEY O'CONNELL EDWARDS

Teaching the poor to knit so that they had a means of earning a living—and also avoided idleness that might lead to “bad habits”—is a recurring theme in English social history from the late sixteenth through the first half of the nineteenth century. But who were the people who taught the poor to knit and what can we learn about them and their work?

During this period, many individual schools were founded, some to teach knitting only, but a number of schools included other subjects as well. Although most teachers taught in schools, records show a few teaching in other settings, such as in the workhouses that were part of civic initiatives.

Available records about knitting teachers and schools often are fragmentary and vary in the information they offer. Some present just brief snapshots; others offer quite a lot of detail, sometimes extending over several years. From them, we can piece together the kinds of characteristics the teachers were supposed to possess, their salaries and other benefits, the wide variety of their situations, and an occasional glimpse of their backgrounds.

The earliest known knitting teacher was Agnes Palmer of Norwich. She is listed in the 1570 Norwich *Census of the Poor* as teaching children to knit. By the 1590s, knitting schools were beginning to be established in a number of places, including Lincoln and York. From that time until the mid-nineteenth century, historical records refer to knitting teachers, almost all of them teaching children. Virtually all the teachers were paid, but there are occa-

sional exceptions, such as the Misses Harrison, members of the gentry, who taught the poor of their Folkington parish to read, knit, and do plain needlework. The school, which was in their house, seems to have started in March 1797, but given that both women married that August, one wonders how long it lasted!

What characteristics were thought suitable for knitting teachers? In Norwich in 1649, the terms of one bequest required that the person who taught girls to spin, knit, and dress wool was to be an aged, discreet, and religious woman. She was to be appointed by the magistrates. In return, the teacher would receive a house, coal, an allowance of bedding and apparel for the girls, and be paid £5 per year for each girl. In 1686 in Lee, the schoolmistress had to be a parishioner of either Lee or Greenwich, as well as grave, motherly, and a sober widow. If she were single, she had to be over fifty. The founding memorandum for the school also noted that the mistress could have a maidservant or a daughter live with her, but not both; and no son was to live in her house.

Throughout the next century, similar strictures stress discretion and sobriety. At Nuneaton, the mis-



The Bayle Gate, Bridlington, England, next to which was located the Bridlington School, where the first headmaster kept all the profits of the business as well as half of each child's earnings. Circa 1890. Collection of the Library of Congress, Prints and Photographs Division (LC-DIG-ppmsc-09044). Photograph courtesy of the Library of Congress Washington, D.C.

ress had to be “of a good life and conversation.” At Cogges, in 1685, the bequest specified the teachers had to be Protestant, possibly a response to the country’s new Roman Catholic king, James II (1633–1701). Most commonly, the teachers seem to have been appointed by trustees of the school, but occasionally they were to be selected by the local vicar, as was the case with the school at Dudleston founded in 1719. Unusually, the mistress at Abberley was elected from among the parishioners.

The most frequently recorded items are the teacher’s salary and any other remuneration. Compensation varied widely, reflecting different economic conditions, mandates, and influences on the school authorities. Benefits in kind, when paid, were usually a rent-free house and occasionally a garden. One unusual benefit was two

loaves every November for the master of the school at Irtlingborough. Most teachers were women; sometimes couples taught under various arrangements. For some positions, students’ earnings were part of the compensation. In 1592 in York, Francis Newbie and his wife, Jane, had thirty pupils, and were paid £2; however, they also earned 2 pence for every stocking Jane and their scholars knitted. (Note: 1 pence [d] equalled 1 old pence or one twelfth of a shilling [s].)

Salaries varied enormously. At Brighton Girls Charity School, the annual salary for teaching knitting and reading was £6 6s in 1703, and £8 in 1706. At Ashbourne, in 1710, the mistress was paid £10 yearly to teach knitting, sewing, and reading. Reading and writing were seen as completely separate subjects, and schools frequently did not include writing for girls. In 1736, the mistress at



The Erpingham Gate, Norwich, England. 1791. Norwich was the home to the earliest known knitting teacher, Agnes Palmer. Pen, black ink, and watercolor by John Carter (1748–1817). Collection of the National Gallery of Art, Washington, D.C. (1992.48.1). Courtesy National Gallery of Art, Washington, D.C.

Raine's Asylum, a school in Wapping, was paid £20 yearly to teach knitting, sewing, reading, and "the like" (unspecified). However, in the 1760s in rural Upper Slaughter, Mary Willson was paid just £4 yearly for teaching knitting, reading, and sewing, until 1775, when the vestry raised it to £6 yearly. For this salary, she had pupils between the ages of five and twelve, the school day ran from 8 A.M. to 12 noon and from 1 P.M. to 5 P.M. She had a week's holiday at Easter and Whitsun and two weeks at Christmas. The knitting teacher in a Bristol workhouse in the 1770s was paid only £2 2s. Salaries also might fluctuate, as was the case in Withington, where the salary was about £1 10s per quarter in the 1770s, but sometimes reduced to less than 10s a quarter during 1792 and 1793, for no given reason.

Some teachers received a salary for a set number of pupils, but others were allowed to take other fee-

paying pupils as well. In 1686, the mistress in Lee had twelve pupils learning the catechism in her school for a salary of £9 yearly, and, if girls, to knit, sew and "mark." In Scotland in 1819, the mistress taught twenty girls reading, knitting, and sewing for a salary of £20 yearly and was allowed to take a further ten scholars on her terms. Ackworth School records reveal that the knitting mistress's salary was to increase from £12 12s to £14 14s in 1807, although other mistresses—including the sewing mistress, and the writing mistress earned more—£15 15s rising to £18 18s.

Sometimes wages were based upon the number of children attending the school, though a teacher's pay might be augmented by their earnings. The teacher of the unidentified Wiltshire school mentioned in the Sotheron Escourt estate papers in the Gloucester Record Office in the 1850s received 3s per week, plus 3d per pupil per week. She averaged nine to eleven pupils in the period recorded, though she received no pay for the five weeks in 1850 when she was ill and unable to teach. In the early eighteenth century, Mrs. Harris, who ran the Artleborough School for the town, which was intended to keep poor children gainfully employed and off the streets, received the profits of the children's labor for the first two months. Thereafter, she earned 2d a week from those who spun, 1½d from those who knitted, and 1d from those who just learned to read. Given the 103 children at the school, she earned a sizeable weekly wage. She both purchased the necessary materials and was responsible for selling the finished items to local dealers. In Oswestry in 1712, the mistress's remuneration seems to have been results based: She was paid 7s 6d when a child could read set texts, and 10s for each girl taught to knit, spin, and sew.

Although male teachers were fewer in number, they taught in three of the larger schools—Lincoln, Bridlington, and York. In 1684, the Lincoln City Council made an agreement with Joseph Newton to be the master of the school for £30 yearly for the first three years, reduced to £20 yearly thereafter. He got a rent-free house, and the city supplied £100 for "stock" for the pupils to knit with.

At Raine's Asylum in Wapping, the older girls who boarded were expected to earn the salaries of the mistress and the cook with their knitting and sewing.

In 1687, John Ashley became the master for £20 yearly. In 1707, Joseph Doughty's appointment came with a salary of £35, though in 1718, John Hooton received a salary of only £30.

At Bridlington, where the school was established in 1670, the payment involved pupils and their production. The first master was Rowland Milner, who was paid a salary and kept all the profits of the business, as well as half of each child's earnings. A formula for computing the master's salary was devised. For example, if each pupil's weekly pay was 5d, then the total yearly amount from twelve pupils would be £13 yearly and the master's salary £6 10s. If the weekly pay was 6d, the total would be £15 12s, and his salary would rise to £7 16s. Obviously, it paid to keep the pupils' noses to the grindstone!

Other examples of price-per-pupil earnings come from settings outside schools. The 1625 Salisbury survey of the poor listed poor children and others placed with "masters" to learn a specific craft trade, with the town paying the master 6d per week from the Poor's stock, a fund designated for "relieving poverty" for the upkeep of the child; eighteen of these pupils were placed with nine masters to learn knitting. In 1788, Thomas Fillmer made a commercial agreement to take the poor of Henfield at 2s 3d per head for an unspecified period and instruct them in various wool crafts, including knitting hose. In Histon, the overseers of the poor set up a manufactory in 1812, from which to distribute materials and to which finished pieces were returned, and hired three teachers to teach knitting at 3d per pupil per week, apparently in their own homes. By the end of the year, there were fifty-six pupils, but numbers then dropped off.

At Raine's Asylum in Wapping, the older girls who boarded were expected to earn the salaries of the mistress and the cook with their knitting and sewing. Clearly, this did not always occur; in 1771, the mistress was allowed a gratuity of 5 guineas (£5 5s) to make up the deficiency in the girls' earnings. In some cases, the wife of the master of a school might be expected to teach girls to knit and sew. In Stoke and Stapleton in the late eighteenth century, the wife of Thomas Phillips, Sarah,

taught the children to knit; sometimes she and sometimes he was paid for her work. In early nineteenth century Sibford Gower and Horley, the masters' wives were to teach knitting. The authorities in Slaithwaite specified that girls would be taught to knit and sew only *if* the master had a wife.

A few records mention what pupils were being taught to knit—virtually always stockings. There were a few exceptions: in 1762, the London Foundling hospital made gloves, and by the mid-nineteenth century, the Female



High Street, Bristol, England. 1821. The workhouse in Bristol paid its knitting teacher a paltry £2 2s per year in the late eighteenth century. Watercolor and graphite on paper. James Johnson (1803–1834). Collection of the Rosenwald Collection, National Gallery of Art, Washington, D.C. (1951.16.157). Courtesy National Gallery of Art, Washington, D.C.

In 1686 in Lee, the schoolmistress had to be a parishioner of either Lee or Greenwich, as well as grave, motherly, and a sober widow.



The Raines Asylum in Wapping, England, where the older girls were expected to earn the salaries of the mistress and the cook with their knitting and sewing. Photograph courtesy of St George-of-the-East-Church, London, England.

School of Industry in Bamburgh, which had begun with stockings, had expanded into other items, including shawls and doilies. How the teachers taught knitting isn't known. They left no records behind. Robert Southey in his book *The Doctor &c.* (London: Longman, Rees, Orme, Brown, Green and Longman, 1848) relates Betty Yewdale's story of a late eighteenth-century Dales school and her description of the knitting master winding three or four yarns together and giving each child an end to knit. The intention was to encourage fast knitting—with all children matching the speed of the fastest knitter so the ball unwound at the same rate. We have no idea if this was a common practice or not. The mid-nineteenth century saw the publication of several instruction books for knitting teachers, usually written in a question-and-answer fashion. One was *The Knitting Teacher's Assistant* first published around 1817.

Only a few records offer personal details about the teachers. Elizabeth Grover was the daughter of the master of the Boy's Charity School in Brighton. She was nineteen when she started teaching at the Girl's Charity School in 1725. Sometimes, pupils might progress to being teachers. For example, the mistress who taught sewing, knitting, reading, and spinning at the Grey Coat School in York in 1801 at the age of twenty-five was a former pupil of the school. Teaching knitting wasn't necessarily an easy option. Elizabeth Elstob, noted scholar and bluestocking, writing in 1735 and 1736, when she was in reduced circumstances, claimed that she wore only stockings she had made. Nevertheless, she wrote

regretfully, she wasn't sufficiently proficient to teach knitting in her school for paupers at Evesham. If knitting did keep people out of mischief and poverty, Dolly Coupland, a teacher in Ravenstonedale, who claimed to have taught three generations to knit, surely did her part. But she is just one of the many knitting teachers who, from the sixteenth to the mid-nineteenth century in England, taught knitting skills that helped many of the poor, especially children, survive in hard times. ❀

Further Resources

- "The Bridlington Knitting School." *Journal of the Bridlington Augustinian Society*, Vol. III, 1926.
- Caffyn, John. "Sussex Schools in the 18th Century." *Sussex Record Society*, 81, 1995–1996.
- O'Connell Edwards, Lesley. "Avoiding Idleness and Bad Habits: Gloucestershire initiatives to improve the lot of the poor." *SlipKnot, the Journal of the Knitting & Crochet Guild*, 116, 2007.
- . "A Charitable Hosiery Enterprise." *SlipKnot, the Journal of the Knitting & Crochet Guild*, 112, 2006.
- . "Knitting Schools in Elizabethan England." *Knitting Traditions*, Spring 2013.

ABOUT THE AUTHOR. *Lesley O'Connell Edwards lives in rural Worcestershire, England, with her husband and two cats. She studies the lives of English working handknitters from the sixteenth to the nineteenth centuries, including knitting schools and teachers. She has researched knitting in late-sixteenth-century England in depth and contributed to the Tudor Tailor book, The Tudor Child: Clothing and Culture 1485 to 1625 (Godalming, England: Fat Goose Press, 2013). For light relief she explores nineteenth-century knitting books and their authors. She is a former editor of the U.K. Knitting & Crochet Guild's journal, SlipKnot.*

A fresh approach to tatting

New Tatting is not your grandmother's tatting book, enjoy 20 projects that redefine the traditional craft.

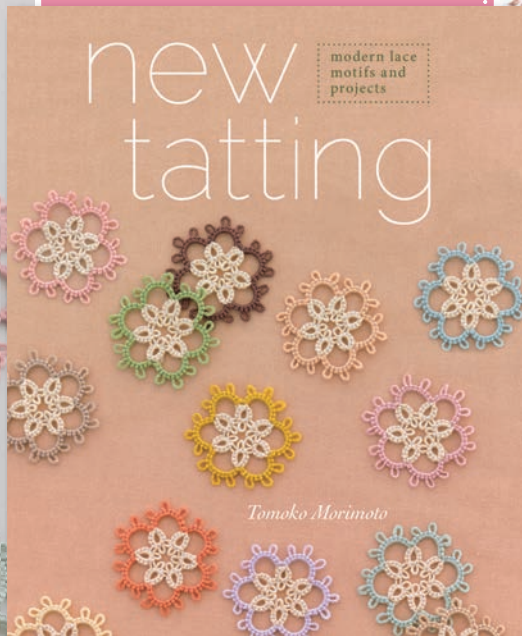

Tomoko Morimoto presents *New Tatting* that is fresh, colorful, and modern. Enjoy tatting 20 projects that appeal to people who have never tatted as well as tatters looking for something new and interesting. With step-by-step photos and eye candy designs, *New Tatting* is the book for the twenty first-century tatter.

Tomoko Morimoto
128 Pages, \$24.99
ISBN 13: 9781596687455

Order or download online at
InterweaveStore.com.



❁ On the Promenade: ❁ The Lace Knitting of Haapsalu, Estonia

NANCY BUSH



As someone interested in the history of knitting, I always have been fascinated by cottage industries. I'm curious to know how knitters used their skills to add to their income and about the techniques they developed to produce their goods. During my travels to Estonia, I was delighted to discover several cottage industries and have embraced one in particular that has a rich past and a very active present.

Knitters in Haapsalu, from left to right: A. Amberg, H. Lao, I. Tammik, L. Tamberg, A. Klems, K. Kõrv. Date and photographer unknown. Photograph courtesy of Läänemaa Museum, Haapsalu, Estonia.

The knitting of lace shawls began in Haapsalu, a small market town located on a beautiful bay on the west coast of Estonia, about 1830. Curative mud was discovered nearby in the early part of the nineteenth century, and mud baths and sanatoriums soon were opened. Attracted by the restorative mud and the wonderful climate, Haapsalu became a summer destination for tourists.

These visitors, whose numbers during the prime seasons reached nearly 4,000, were comprised of the wealthy and well-dressed part of society from Germany, Scandinavia, Russia, and beyond. There are different theories about what first led knitters in the town to create the airy shawls and scarves for which they became famous. It might be that an Estonian-Swedish family (the Haapsalu area has had a Swedish population for several centuries) introduced the craft of lace knitting to Haapsalu, or perhaps elegant ladies were observed wearing knitted lace shawls, such as those from Orenburg, Russia, thus encouraging a new fashion. Regardless of lace knitting's origins, the knitters of Haapsalu saw a potential for income, and their cottage industry was born.

Early shawls were knitted from handspun wool and were simple, without *äärepits* (the lacy scalloped edges). Later, when fine millspun yarn could be imported, the shawls grew finer and the patterns more complicated. Fine yarn was an attraction for prospective buyers. Although some shawls were made in pastel colors, the most popular color was and continues to be white. A skilled knitter could complete twenty to thirty shawls during the quiet winter months; a family working together could complete as many as eighty shawls before the summer tourists arrived.

Knitters would meet on the promenade, the walkway along the edge of the bay, gathering in groups, with their baskets of shawls and their knitting in their hands, selling their wares to wealthy tourists. Knitters also sold scarves and shawls at the dock where ships called on their way north to Tallinn, Estonia, and on to St. Petersburg, Russia. Soon the shawls became famous throughout Europe. Shawls and scarves made in Haapsalu were at the height of their popularity at the end of the nineteenth and the first decades of the twentieth century.

A classic Haapsalu scarf was square, measuring about 40 by 40 inches (101 by 101 cm) or larger, and consisted of three distinct patterns—one for the center, another for the border, and a third for the edge. The center and border were knitted in one piece, and the edge was knitted



Master knitter Anette Martson, center, with her students in 1913.
Photograph courtesy of Läänemaa Museum, Haapsalu, Estonia.

separately in two parts and sewn onto the main piece. Because the knitters used handmade wooden single-pointed needles (about 10 inches [25 cm] long), they needed to make the edge in two parts so the stitches would fit onto the needles. The knitters did not have circular needles until modern times. Rectangular shawls, measuring about 20 by 70 inches (51 by 178 cm) also were popular. These shawls had a center pattern surrounded by a lace edge. Triangular pieces were made beginning in the 1930s. All three shapes are still made today.

There were no written instructions for the patterns—the techniques, designs, and skill of knitting were handed down from one generation to the next. Children as young as four were given simple patterns, and by the time they

A Center for Lace

In 2003, to celebrate and promote the story of knitting in Haapsalu, the Haapsalu Rätiku Muuseum [Museum of the Haapsalu Scarf] was born. Located in a small room in an art and craft center, it contained an exhibit of knitted shawls, scarves, and dresses, as well as historic images of knitters and awards given to them for outstanding work.

The museum was started by Haapsalu artist and teacher, Aide Leit-Lepmets. Under her enthusiastic care and guidance, the museum was open during summer months, giving visitors to Haapsalu the opportunity to learn more about the shawls and their history. At the beginning of 2013, Aide offered the care of the museum to the Haapsalu Käsitööselts [Haapsalu Handicraft Society].

Founded in 1992, the Haapsalu Käsitööselts was created to safeguard and promote local handcraft, especially lace knitting, in the town, the surrounding province, and Estonia, in local markets and national events. The society organizes field trips to study special collections, offers workshops to learn new skills, and has created a strong network of skilled craftspeople. Today, the Haapsalu Käsitööselts has more than sixty members. Several years ago, according to Mirje Sims, the acting leader of the society, there were “few whose age did not begin with the number six, seven, or eight.” The youngest current members are nine and ten, and the oldest is ninety-three. One strong and active group is comprised of women who are about eighty. They make up about a third of the membership. Even at their “great age,” they support the ideas and innovations of the younger members. These masters are fine teachers in various fields of handcraft, especially in knitting lace.

Currently, the society offers encouragement to knitters who want to sell their shawls at Christmas fairs and other craft markets. If the society receives orders for shawls, the orders are passed along to their members. Members aren't required to sell their work through the society, but are free to sell however they wish.

The members of the Haapsalu Käsitööselts were already involved with the Haapsalu Scarf Museum, knitting samples of the many lace patterns for display and spending time in the museum talking to visitors, sharing their unique knowl-

edge. They also have created a showplace for Haapsalu lace in their annual Pitsipäev or Lace Day. Held in August, this festival of lace celebrates the heritage of the town and the knitters, past and present, who have supported it.

The Haapsalu Käsitööselts was considering Aide's offer to take over running the museum when, in the summer of 2013, the mayor of Haapsalu, Urmas Sukles, and the local government, realizing that they had a wonderful opportunity to promote the history of the town and support the craft of lace knitting that has flourished there for nearly two hundred years, offered a building on the main shopping street to the Haapsalu Käsitööselts. This structure will offer the society a real home, a place where members can meet and continue to pursue their interest in handcraft. The new building will be known as the Haapsalu Pitsikeskus [Haapsalu Lace Center], placing under one roof the Haapsalu Rätiku Muuseum and the Haapsalu Käsitööselts. Plans are underway to renovate the space, including placing some of the white benches that grace the shoreline in summer inside the center during the winter months to give local knitters their traditional benches upon which to knit.

Soon a curator will be in place to take charge and organize the center, which will include a gallery space, a teaching area, and a shop that will focus totally on lace-related items, as well as a room for looms and storage for the knitted lace items that have been donated to the Haapsalu Rätiku Muuseum. Other than the rent and salary for the curator, the activities will be funded by the society.

With great enthusiasm, the members of the Haapsalu Käsitööselts have embraced this turn of fortune with open arms. The aim, according to Mirje Sims, “is to introduce, teach, and preserve handcraft and, above all, Haapsalu lace.” The official opening of the Lace Center occurred on February 2, 2014.

Plans are underway to begin a Support the Haapsalu Lace Center project. If you would like to know more, please send an email to woolywest@gmail.com with Haapsalu Lace Center in the subject line, to be added to the mailing list.

—N.B.

were eight, they could knit the lace edges that were sewn onto the completed centers. Stitch patterns were recorded on long knitted samplers or on individual sample pieces. The knitter would study the sample, deciphering the pattern without the aid of charts or

written instructions. It wasn't until the 1930s that knitters began to use printed patterns with graphed symbols.

During Estonia's first independence (from 1920 to 1940), knitting courses were taught at the local technical college in order to encourage knitters in Haapsalu. Teachers were

trained there, and students could take courses in the special techniques involved in Haapsalu shawls. Haapsalu shawls were advertised worldwide during this time.

In the 1930s, more than 500 residents of Haapsalu were involved in knitting shawls. Master knitter, Anette Martson, (1879–unknown) had more than fifty knitters working for her. She supplied yarn to each knitter; when the shawl or scarf was completed, she did the finishing work of washing and blocking; she also organized the sale of the shawls and scarves.

World War II (1939–1945) disrupted the local cottage industry. The knitters of Haapsalu continued knitting shawls and scarves during the Soviet occupation from 1944 to 1991, but their situation had changed. Cooperatives were started and by 1966, the shawls were produced for the craft cooperative UKU, which operated a workshop in Haapsalu. Each knitter had to complete a quota of nine shawls or twelve scarves each month (knitters with disabilities were given half that quota). UKU provided the yarn to the knitters, but the knitters were paid little for their work.



View from the bench dedicated to Nancy Bush on the Promenade—the historic path where lace knitters have gathered to knit and, in past times, to sell their shawls and scarves. 2013. Photograph by and courtesy of Catharina Forbes.



Haapsalu knitter Maria Bogdanova with a shawl on blocking boards. Circa 1950. Photograph courtesy of Läänemaa Museum, Haapsalu, Estonia.

With the end of Soviet occupation, life in Estonia changed dramatically again. For the knitters in Haapsalu, it meant freedom to knit what they wanted to and to sell their work themselves. Today, a market for the lace shawls of Haapsalu flourishes in the town itself as well as shops in Tallinn and elsewhere in Estonia. The knitters in Haapsalu, while perhaps not sharing skills mother to daughter, still make their shawls in the traditional method, with the lace edge, if there is one, attached by sewing to the completed center. Three or four instructors teach lace knitting in the public schools in Haapsalu, and shawl-knitting courses for older students are offered at the Haapsalu Vocational School. The cottage industry tradition continues, though knitters today can no longer make their entire living by knitting shawls. ❁

ABOUT THE AUTHOR AND DESIGNER. Nancy Bush, a member of PieceWork magazine's editorial advisory panel and a frequent PieceWork contributor, writes books on knitting and teaches knitting workshops in the United States and abroad. She lives in Salt Lake City, Utah, and owns the Woolly West, an online source for knitters; visit www.woolywest.com.

A companion project follows

Kajakakiri Stole

DESIGNED BY AIME EDASI; KNITTED BY PILLE KÄLLE
ENGLISH PATTERN BY NANCY BUSH

Inspired by the preceding article



Elegantly capturing the lightness of a sea breeze from the promenade at Haapsalu Bay, Aime Edasi's Seagull Stole incorporates traditional Estonian lace design elements and construction. Photograph by Joe Coca.

The inspiration for this new pattern called Kajakakiri (Seagulls) from Haapsalu, Estonia, designed in 2013 by master knitter Aime Edasi, was the view from a very special bench located along the promenade, the walkway that follows the coastline of Haapsalu Bay. The promenade is the historic path where lace knitters have gathered to knit and, in past times, to sell their shawls and scarves. Lace knitters in modern Haapsalu still enjoy this tradition of meeting at one of the benches to knit together.

The bench where Aime was inspired to create this design has a very special meaning for me. In June 2013, I was in Haapsalu with a group of knitters and was surprised and overcome with emotion when I was publicly “given a bench,” complete with my name and an inscription. This gift was the idea of my dear friend Anu Kaljurand; members of the knitting community in Haapsalu joined with her in organizing it. What a wonderful gift it was and a moment I will always remember.

One of my favorite things to do when I am in Haapsalu is to rest on one of these lovely benches to knit and to enjoy the view of sea, sky, and the gulls and swans that pass by. Now there is a bench waiting for me, and my connection to this wonderful town and the people who live there has become even stronger.

—Nancy Bush

Instructions

Note: See page 124 for Abbreviations and Techniques.

Center

With largest single-pointed needle in right hand and smallest single-pointed needle in left hand, using the knitted method, CO 117 sts. Cont using smallest needles. Sl 1st st of every row pwise wyf throughout.

K 6 rows—3 garter ridges.

[Work Rows 1–42 of Zigzag Chart, then work Rows 1–30 of Seagulls Chart] 6 times, then work Rows 1–42 of Zigzag Chart once more.

K 7 rows.

With WS facing, BO as foll: Sl 1 pwise, *k1, k these 2 sts tog (as for ssk); rep from * to end.

Break yarn and pull rem st up to fasten off.

Lace Edge

Notes: The lace edge is worked in one piece, which, when attached by sewing, will go around the entire shawl. If you prefer to work the lace edge in two pieces, follow the instructions below for the lace edge but cast on 481 stitches for each piece.

With yarn doubled, largest needle in right hand and middle-size needle in left hand, and using the knitted method, CO 961 sts. Break 1 strand of yarn, leaving a 20-inch (50.8-cm) tail, and cont with a single strand and middle-size needle. Work Rows 1–17 of Edging Chart once, then BO as for center.

Join Lace Edge to Center Section,

Notes: The lace edge is joined so that the widest part of a scallop is centered over each corner. The two ends are joined at the corner where they meet (or at two opposite

Materials

Soft Touch Lace, 100% wool yarn, laceweight, 550 yards (502.9 m)/50 gram (1.76 oz) ball, 3 balls of Natural White; www.shelridge.com (Note: Soft Touch Lace is slightly heavier than the original yarn used for the project, which is a 2-ply laceweight, 100% wool yarn, 1575 yards [(1440.2 m)]/ 100 gram [3.5 oz] skein available only in Estonia.)

Needles, single point 10 inches (25.4 cm), size 2 (3 mm), size 4 (3.5mm), and 1 size 8 (5mm), and circular, 32 inches (80.0 cm) or 40 inches (100.0 cm), size 4 (3.5 mm) or size needed to obtain gauge

Markers

Tapestry needle

Finished size: About 23¼ inches (59 cm) wide and 58¾ inches (149 cm) long, after blocking

Gauge: 27 sts and 36 rows = 4 inches (10.2 cm) in Zigzag patt on smallest needles, after blocking

corners if the edge is made in two pieces). The edge is sewn onto the center with a single strand of yarn, which is attached to the ball. This sewing yarn is not cut until the lace edge is attached and eased around all four corners (to ensure that it will stretch as much as possible). Arrange the edge so you begin sewing at the right-hand corner of the shorter side (can be either end). There is one-half of a scallop at the start, ten full repeats across the width of the shawl, and one-half of a scallop to reach the next corner. The second half of this scallop is the beginning of the sewing on the long side. This side has twenty-eight full scallops and ends at the next corner with one-half of the next scallop. Repeat this for the next two sides.

Sew as foll: Hold center section and lace edge with RS tog and so that center piece is closest to you. Beg at a corner of a short side of center piece. With yarn from ball threaded on the tapestry needle, take the 1st 3 sts from lace edge and 1 st from center piece. Rep this 3:1 ratio 2 more times. Next, take 2 sts from lace edge and 1 st from center piece. Rep this 2:1 ratio 2 more times. Then alternate taking 1 st from lace edge and 1 st from center (1:1) until you are 15 sts from end of half-scallop that will form corner and 6 sts from corner of center section. Take 2 sts from lace edge and 1 st from center piece (2:1) 3 times, then take 3 sts from lace edge and 1 st from center (3:1) 3 times to end at corner.

Notes: You will need to make small adjustments in the sewing so that you end up at the corner stitch of the center piece and the exact center of a scallop on the lace

Zigzag Chart

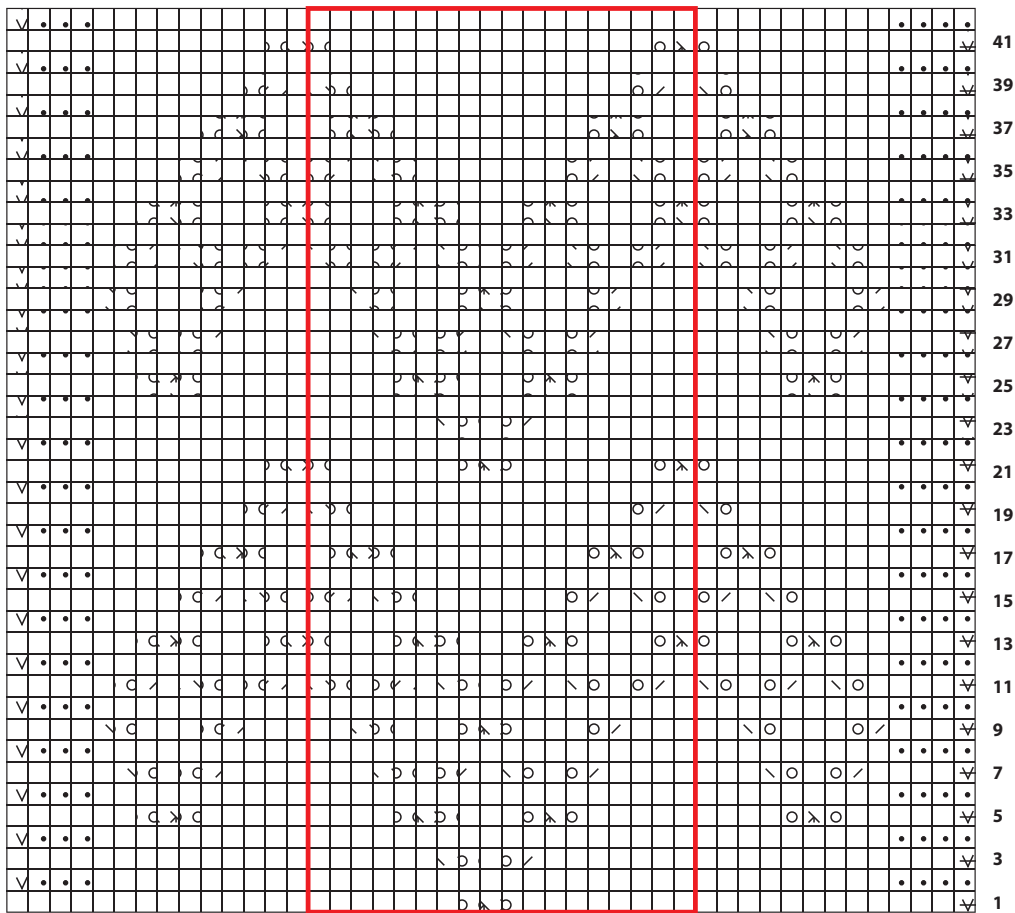

18-st rep



Detail of Zigzag and Seagull designs on the Seagull Stole designed by Aime Edasi and knitted by Pille Källe. Photograph by Joe Coca.

edge. Make adjustments by taking more or fewer stitches along the edge piece as needed (for instance, 2:1 occasionally). Do not skip any edge stitches or you'll end up with unsightly holes where the lace is attached to the center piece.

At corner of long side of shawl, take 3 sts from lace edge and 1 st from center (3:1) 3 times, then take 2 sts from lace edge and 1 st from center (2:1) 3 times. Then work down edge of shawl (selvedge edge of center piece), alternating 1 st from lace edge and 1 st from center piece 2 times, then 2 sts from edge and 1 st from center once (1:1, 1:1, 2:1) until you are 15 sts from center of scallop that forms next corner and 6 sts from corner of center section. Next, take 2 sts from lace edge and 1 st from center piece (2:1) 3 times, then take 3 sts from lace edge and 1 st from center piece (3:1) 3 times.

Cont to sew 2nd half of lace edge to center piece as above. When entire lace edge is attached, sew corner where 2 ends meet, using the tail that was not woven in earlier. Do not sew corners with yarn used to attach lace edge. If edge was made in 2 pieces, sew 2 corners tog where pieces meet.

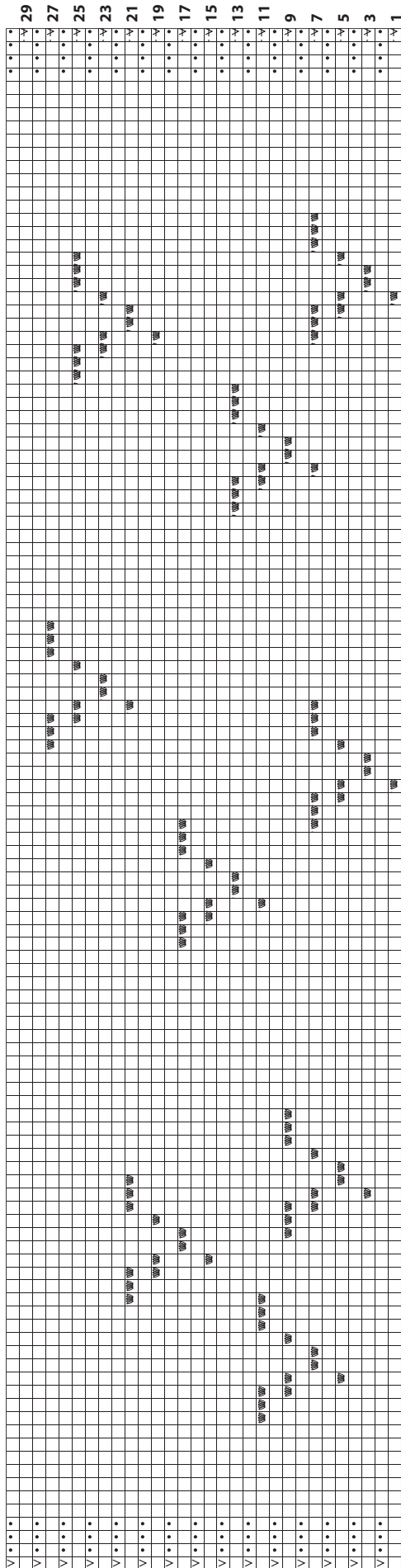





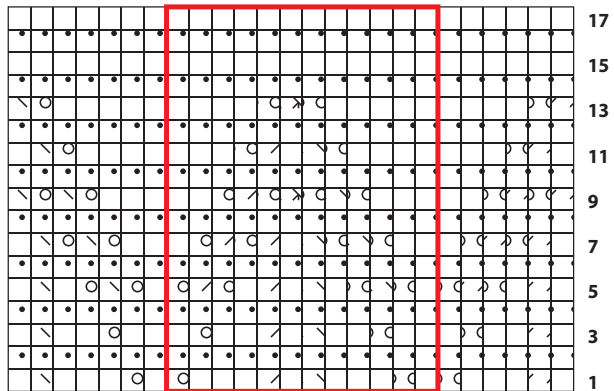





117 sts

Edging



12-st rep

Key

-  k on RS; p on WS
-  p on RS; k on WS
-  yo
-  k2tog
-  ssk
-  sl 1, k2tog, pss0
-  sl 1 pwise wyf on RS
-  sl 1 pwise wyf on WS
-  9-st nupp: working loosely, ((k1, yo) 4 times, k1) in same st; on next row, p9tog
-  patt rep

Carefully pull sewing yarn, connected to ball, so there are no puckers, gathers, or tight spots in seam between center and lace edge, being careful not to pull cut end of sewing yarn through sewn sts. When lace edge is connected evenly all around, cut sewing yarn from ball and carefully weave in loose ends. Cut the ends after blocking.

Finishing

Wash finished shawl in warm water and mild soap. Do not wring. Pin to desired shape. Place a damp towel over shawl to block. 🌸

Charts may be photocopied for personal use.

The charts for this project are available in PDF format at pieceworkmagazine.com/Charts-Illustrations.

✿ Binge: ✿ Industrious Knitting in South Sweden

CAROL HUEBSCHER RHOADES

When English-speaking knitters read about the *binge* knitting tradition in the Halland province of Sweden, they immediately think of nonstop knitting and, in a way, they're right. Both *att binga* and *att binda* are very old regional dialect words for the verb "to knit," but *binge* has become the word denoting a knitting style popularized in the early twentieth century.



Knitting as a cottage industry began as early as the seventeenth century in Halland, a province along the southwest coast of Sweden. Stockings and sweaters were knitted by the thousands and sold through buyers who organized the knitting and marketing. Knitters worked at home, while on the go, and at knitting parties (*bingegille*). Knit/purl texture and two-color stranded knitting patterns were made up into relatively simple garments, primarily for working men and soldiers. Families worked together to produce the garments as quickly as possible, with children often knitting the sleeves while adults knitted the sweater bodies; often two people knitted a piece simultaneously. During the eighteenth century, the Swedish army purchased thousands of Halland stockings.

A great deal of knitwear was sold at both the 1909 Stockholm Exhibition and the Baltic Exhibition in 1914. Lars Petter Jönsson and his wife Beata (both dressed in Halland costume) demonstrate knitting. People often worked together on the same garment, usually large sweaters. Photograph courtesy of the Halländska Hemslöjdsföreningen Bindslöjden [Halland Art Museum], Halmstad, Sweden.

The nineteenth century brought many changes to life in Sweden. Industrialization meant different working conditions and opportunities as well as cheaper, more quickly produced clothing. It wasn't long, however, before the recently emerged middle classes in Scandinavia and elsewhere realized that industrialization also meant a loss of many cultural traditions. Arts and Crafts movements and organizations, including the Swedish Handcraft [Föreningen för Svensk Hemslöjd], founded in 1899, sought to preserve local handcrafts, emphasizing well-made, functional work that was also beautiful. At the same time, for some at least, the outdoors became a place to be enjoyed, not just where one toiled for a subsistence living. Social reformers looked for ways to help those left behind or not served well by industrialization. Berta Borgström (dates unknown), wife of the doctor in Laholm, Halland, wanted to help women in need and to preserve the local knitting traditions. She advertised for knitters and sourced yarn for garments that could compete with industrially produced work. The yarns, Paton's Super Fingering and Super Wheeling (advertised as "the ideal" yarn for socks, jerseys, scarves, and caps), were imported from the United Kingdom because they were soft but firmly plied and better spun than yarns then available in Sweden. Borgström also inventoried pattern motifs in the area, collecting swatches from various knitters. The first knitter she hired made forty pairs of patterned long stockings that winter. With a number of very industrious knitters and the right yarns chosen, Borgström worked with others to establish the Halland Knitting Craft Association [Halländska Bindslöjdsföreningen]. The word "Binge" was used by the craft association as that was how the knitters referred to their work. As they promoted their products, the dialect words stayed as part of the tradition; although, the garments and association would have been known more generally by reference to Halland, the province. Genuine goods were indicated by a handsomely patterned label Berta Borgström designed, with the Bjärbo and flower motifs signifying work done by the Halland Knitting Craft Association.

The Bjärbo motif is a very stylized version of a thistle-like flower with three branches. The flowers are diamond-shaped, usually with a solid diamond topped by a check pattern diamond. The "flower" is outlined with a hexagonal border and the motifs are staggered vertically and horizontally. The motif almost always is worked with three colors—white for the background with alternating wide horizontal stripes in blue and red.



Mother and daughter in sweaters and hats knitted with the Bjärbo motif. Photograph believed to be from 1914. Photograph courtesy of the Halländska Hemslöjdsföreningen Bindslöjden [Halland Art Museum], Halmstad, Sweden.

The organization quickly grew to 115 knitters and, by 1911, had its own premises. A military equipment company placed a large order early on that insured the group's success. Halland's knitwear also became popular with men and women active in sports. Exhibitions in Stockholm and Berlin as well as a catalog first printed in 1910 helped to market the garments, which offered high quality at a reasonable price. Because the middle and upper classes visited beaches near Laholm during the summer season, the knitters set up beach umbrellas to display and sell goods. During the 1930s and 1940s, the association's output even included stylish woolen swimsuits. Royalty in Sweden and Denmark ordered and wore Binge jackets, caps, mittens, and stockings, further popularizing the garments. By the 1930s, Halland knitting was exhibited and sold as far away as Chicago and New York. The association was able to continue production even during World War II (1939–1945), although yarn from England became scarce. After the war, the quality of Swedish yarn greatly



Two women knit as the afternoon sun shines in through the window. Note the long knitting needles as well as the holder for the yarn on the bench in foreground of the photograph. Photograph courtesy of the Halländska Hemslöjdsföreningen Bindslöjden [Halland Art Museum], Halmstad, Sweden.

improved and the organization switched to yarns from Klippan, which spun a three-ply yarn dyed with red, blue, white, or brown. Later, Bergå's Stickgarn Extra was used. Garments knitted with the Klippan and Bergå yarns were worked on U.S. size 1½ to 2½ (2.5 to 3 mm) needles. Many of the older knitters kept to their double-pointed needles even after circulars became more available in the 1940s. The double-pointed needles were usually metal, sometimes made from umbrella wires. Smaller items were worked with five double-pointed needles while larger pieces were divided over eight to ten.

As did the Swedish Bohus knitting cooperative (1939–1969), the Halland craft association treated its workers well and maintained high-quality standards for its products. Before the association was established, the Halland knitters made large pieces that could be fulled down to size; the fulling also hid knitting errors and irregularities in the handspun yarn. After 1907, the association worked carefully to insure that all the garments they sold were well-designed, knitted, and finished. Sweaters were knitted in the round, with sleeves worked down to the cuff.

The association's Binge sweaters were knitted in the round from the lower edge up. Sleeves were knitted



Two women wearing Binge sweaters—samples from the Halland Knitting Craft Association's early production. The woman at right is wearing a sweater knit in the Bjärbo pattern. Photograph courtesy of the Halländska Hemslöjdsföreningen Bindslöjden [Halland Art Museum], Halmstad, Sweden.

separately, from the cuffs up, so that the stitch direction and pattern matched that of the body. An important feature of this high-quality clothing was the tailoring. Customers could order garments that then would be fitted for them. For larger garments, such as coats, the fabric for the body was knitted in the round with a steek. The steek was then cut open and the fabric blocked so it could be cut for shaping as if it were woven fabric. In the 1930s, the association even sold 27½-inch (69.8-cm) wide lengths of handknitted and patterned fabric that buyers could then fashion into their own garments. Almost from the beginning, single-color stockinette pieces were knitted by machine.

The motifs for the garments were chosen and adapted from traditional patterns in Halland province, with the Bjärbo, flower, and hook motifs being early favorites. It's always difficult to pinpoint the precise origin of any motif, and several of the pheasant, floral, dancing boys and girls, and simple geometric motifs can be found elsewhere in Sweden and beyond.

One factor behind the lasting success of Halland knitting is that, although garments generally were produced within a narrow color range and pattern assortment, they were always up-to-date in terms of fashion silhouette and fit.

Although some early jackets were styled to be worn over corsets, those were dropped when 1920s fashion dictated looser fits for more active and sporty people. Many of the garments were knitted in dark red with a yellow undertone and navy blue against a white background, but reverse or alternate color placement wasn't uncommon. When the centenary exhibition of Halland knitting was mounted in 2007, a scrap of fabric left over from a coat knitted for the 1940s Swedish actress Gudrun Brost (1910–1993) was made into a tiny doll's sweater and cap. The Bjärbo pattern had been worked in light blue and pink—a surprising color scheme for the original coat. However, as Kirsti Nilsson, handcraft consultant, said, “You can choose the colors that suit you or choose this season's fashion colors. You don't need to be locked into the colors that were used previously. You have to be a bit daring!”



Harriet Dock, left, worked with the Halland Knitting Craft Association from its establishment. Displayed behind her companion are sweaters in various patterns and, at the top, a number of doubled caps, each with different pattern panels. Photography courtesy of the Halländska Hemslöjdsföreningen Bindslöjden [Halland Art Museum], Halmstad, Sweden.

By the 1950s, the focus had shifted more to supplies and patterns for customers to knit their own Binge garments, although special orders still were received and new garments and knitted items such as ponchos and pot-holders were developed and marketed into the 1960s and 1970s. The association closed the Laholm shop on April 30, 1975, and consolidated operations in the larger city of Halmstad. By the 1980s, only about ten knitters remained working. Nevertheless, Binge knitting still attracts notice and new knitters—Japanese magazines occasionally feature fashion knits sporting traditional Halland motifs and colors. The Handcraft [Hemslöjden] shop in central Halmstad still stocks a selection of Binge yarns, kits, books, and garments. The association also continues to offer workshops, exhibitions, and talks on the subject around Sweden. A traveling exhibit, *Björbomönstret—traditionellt stickmönster på nytt sätt* [The Bjärbo Pattern—New Versions of a Traditional Pattern] opened in Laholm in August 2013. Searching the Internet for “Halland knitting” or “halländsk stickning” reveals continuing interest in its history and styles. Be a little daring and follow the Binge tradition by inviting knitting friends to your own *bingegille*. ❁

Further Resources

- Binge: en halländsk sticktradition* [Binge: A Halland Knitting Tradition]. Halmstad, Sweden: Halländska Hemslöjden, 2007.
- “Hundra år med halländsk bindslöjd” [100 years of Halland Knitting]. *Laholms Tidning*, Sommer 1, 2007, 30-31.
- Blomberg, Mymmel. *100 år med Binge: en halländsk sticktradition* [100 Years of Binge: A Halland Knitting Tradition]. Halmstad, Sweden: Halländska Hemslöjden, 2007.
- Johansson, Britta, and Kersti Nilsson. *Binge: en halländsk sticktradition* [Binge: A Halland Knitting Tradition]. Stockholm, Sweden: LTs förlag, 1980.
- Pagoldh, Susanne. *Nordic Knitting: Thirty-One Patterns in the Scandinavian Tradition*. Loveland, Colorado: Interweave, 1987. (See pages 59-61 for information about Halland Knitting).
- Palmköld, Anneli. “Avsalustickningen i södra Halland: från vardagsvara till hemslöjdsprodukt” [Knitting for Sale in south Halland: From everyday garments to handcraft product]. Seminar paper, Lund University, 1990.
- Palmköld, Anneli. “Knitting for Income in Halland, Sweden.” *PieceWork*, Jan/Feb 2010.

ABOUT THE AUTHOR AND DESIGNER. Carol Huebscher Rhoades lives in Madison, Wisconsin, where she enjoys knitting and crochet-ing traditional patterns. She researches Scandinavian, German, and British knitting traditions and translates Scandinavian knitting and crochet books into English.

A companion project follows

Binge Bjärbo Cap from Sweden

CAROL HUEBSCHER RHOADES

Inspired by the preceding article



I was lucky that when I started studying the Swedish language, Elizabeth Zimmermann at Schoolhouse Press was importing knitting books from Sweden. The books provided a fun way to improve both my language and knitting skills. It also was interesting to learn about the various regions of Sweden because I could associate knitting traditions with several of them.

Materials

Brown Sheep Naturespun, 100% wool yarn, sportweight, 184 yards (168.3 m)/50 gram (1.8 oz) ball, 2 balls of #1475 True Blue Navy (MC) and 1 ball each of #7305 Natural (CC1) and #N465 Red Fox (CC2); www.brownsheep.com

Needles, circular, 24 inches (60.0 cm), and set of double pointed (or Magic-Loop circular), size 1½ (2.5 mm) or size needed to obtain gauge

Crochet hook, size C/2 (2.75 mm), for provisional cast-on

Waste yarn, about 5½ yards (5.0 m), smooth, for provisional cast-on
Stitch markers

Finished size: Medium, 21 inches (53.3 cm) in circumference, to fit a head 22 to 23 inches (55.9 to 58.4 cm) in circumference; 8½ inches (21.6 cm) high from purl fold line to top of cap

Gauge: 7 sts and 8 rows = 1 inch (2.5 cm) in 2-color stranded St st, worked in the rnd

What I like about Scandinavian knitting books is that they often include the history of a knitting tradition. *Binge, en halländsk sticktradition* [Binge, a Halland Knitting Tradition] (Halmstad, Sweden: Halländska Hems-löjden, 2007) was one of the first books I bought.

The Bjärbo pattern for the cap is the most easily recognizable Binge motif. The name refers to a person living on the Bjäre peninsula in southwest Sweden. Because the motif is rather long when repeated as a staggered pattern motif, it isn't seen on caps very often, but when I was almost finished with my cap brim, I was leafing through the Binge book and spotted a cap similar to mine. (See photograph on page 65.) The 1914 photograph shows a mother and daughter wearing Bjärbo sweaters and caps, described in the caption as "elegant sports clothes."

Instructions

Notes: See page 124 for Abbreviations and Techniques. The cap is lined, so you will not have to catch

long floats in the two-color stranded knitting. Just make sure that the floats stretch comfortably across the underlying stitches.

Cap

Brim,

With waste yarn and crochet hook, work 150 sts over cir needle for crochet provisional CO. With MC, k150 sts. Join for working in the rnd, being careful not to twist sts. Pm for beg of rnd. P 1 rnd (brim fold line), k 1 rnd.

Add CC1 and work Rnds 1–33 of Bjärbo Motif Chart, working the 30-st patt rep 5 times each rnd.

Cut all CC yarns and cont with MC only.

K 1 rnd, p 1 rnd, k 5 rnds.

Crown,

Beg crown shaping, changing to dpn when sts no longer fit around cir needle.

Dec Rnd: *K23, k2tog; rep from * 5 more times—144 sts rem.

K 1 rnd.

Dec at 8 points around the cap as foll.

Dec Rnd: Remove m, *k16, k2tog, pm; rep from * 7 more times—136 sts rem.

Next Rnd: K.

Dec Rnd: *K to 2 sts before m, k2tog, sl m; rep from * 7 more times—8 sts dec'd.

Rep last 2 rnds 15 more times—8 sts rem.

Cut yarn and draw end through rem sts. Tighten and weave in all ends neatly on WS.

Lining

Ravel provisional cast-on, picking up the 149 live sts around. With MC and RS of outside facing, k 1 rnd, dec 1 st—148 sts rem.

Work in k2, p2 rib until lining is same length as outside of cap to 1st Dec Rnd (about 40 to 42 rnds).

Beg crown shaping,

Dec Rnd: *Work 35 sts in rib, k2tog; rep from * 3 more times—144 sts rem.

Next Rnd: Work even in rib, being careful to keep continuity of patt.

Carol Huebscher Rhoades's cap with the distinct Binge motif, the Bjärbo pattern, named after a person living on the Bjäre peninsula in southwest Sweden. Photograph by Joe Coca.

Cont in rib, dec at 8 points around the cap as for the outside of the cap, working all decreases as k2tog and dec'd sts as k1 for a smooth dec line in the ribbed crown. Finish by cutting yarn, drawing end through rem 8 sts and running end to inside of lining.

Finishing

Handwash cap in lukewarm water with wool-safe soap. Rinse in same temperature water. Lightly squeeze out excess water, and roll in towel to absorb more water. Lay cap flat to dry. ❁



Brim edge and lining of Carol Huebscher Rhoades's Bjärbo-patterned cap. Photograph by Joe Coca.

Bjärbo Motif

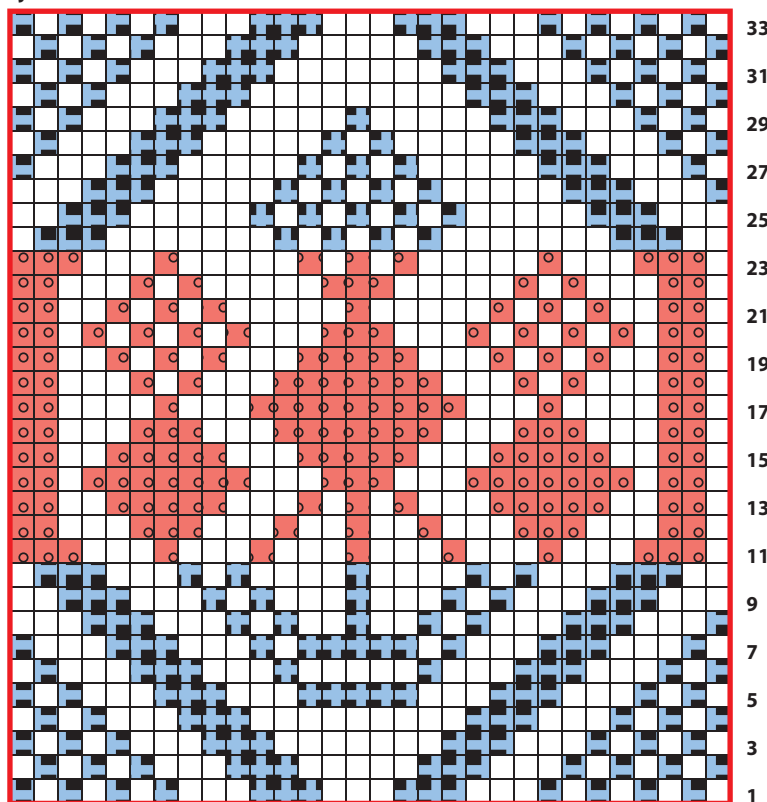

30-st rep



Key

- k with MC
- k with CC1
- k with CC2
- patt rep

Chart may be photocopied for personal use.

The chart for this project is available in PDF format at pieceworkmagazine.com/Charts-Illustrations.

✿ The Industry of Women: ✿ Emma Jacobsson and Bohus Stickning

COURTNEY KELLEY

The 1930s brought a deep economic depression to many countries around the world. In the early years of this depression, native Austrian, Emma Jacobsson (1883–1977) began to sow the seeds that would become the Bohus Stickning (Bohus Knitting) organization.



Several original Bohus Stickning sweaters, showing multiple colors and purl stitches emblematic of Bohus knitting. Clockwise from top left: Lemon by Annika Malmström-Bladini, 1957; New Azalea by Kerstin Olsson, 1964; Winter Haze by Annika Malmström-Bladini, 1957; Blue Egg by Kerstin Olsson, 1964; Bumble Bee by Anna-Lisa Mannheimer Lunn, 1953; Green Wood by Kerstin Olsson, 1960. Collection of Susanna Hansson; www.oneofsusannas.com. Photograph by and courtesy of Susanna Hansson.

In 1934, when her husband, Malte Jacobsson (1885–1966), was elected governor of Bohuslän, Sweden, Emma Jacobsson’s world changed from that of an art historian and researcher to that of a governor’s wife. This region in western Sweden was suffering severe economic decline. The main industry of the region was stone cutting, and Bohuslän stone paved roads all over the world. As the Depression spread from the United States around the globe, demand for new paving stones slowed to a halt. Along with a decline in the fishing industry and tough agricultural times, many families faced disaster.

Augusta Teng (dates unknown), a politically active woman in the region, had been traveling the coast teaching knitting and sewing workshops to local women to help them earn some income. In a visit to the governor’s home in Göteborg in 1937, she, along with members of the Social Democrat Women’s Club, enlisted Emma’s help. Together, the women devised various ways for the region’s women to earn money, ways that didn’t take them away from their duties at home. They started the Bohuslän Domestic Industry, which at first made Christmas ornaments, then stuffed animals, and finally utilitarian socks and mittens for the workers along the coast. The socks and mittens were the most popular of the items attempted and were even sold at the Swedish Handicraft Store in Stockholm.

Emma, a burgeoning businesswoman, quickly realized that the knitted items could command a higher price if they were embellished. The initial embellished items were embroidered and were very well received by the public. That positive reception was the first inkling that she and the women of the Social Democrat Women’s Club were onto something. Based on the success of these early attempts to create a cottage industry for the women of Bohuslän, Bohus Stickning was founded in 1939.

Once the women of Bohus Stickning realized the popularity of their embroidered knits, they began expanding their repertoire. Using her fine-arts background, Emma began painstakingly sketching and swatching simple stranded colorwork designs. The early embellished designs were uncomplicated and not what one thinks of as quintessential Bohus knitting. Bohus knitting has been defined by its intricate stranded colorwork, often with more than two colors per row, and at times, as many as five. It also incorporates purl stitches on the right side of the fabric, a technique that creates a depth and texture to the colorwork that could not be achieved by color stranding alone. The first designs Emma developed were simply well-executed stranded colorwork with a modern design



The original Vävsnaden, “The Woven One” or “The Woven Fabric,” a very early sweater design by Bohus Stickning founder Emma Jacobsson.

Photograph © The Bohuslän Museum, Bohus, Sweden.

sense and appeal. Bohuslän had no particular regional knitting style—nothing as recognizable as the black and white snowflake motifs of the Selbu region of Norway (typically referred to simply as “Selbu Knitting”) or the tvåändsstickning (twined knitting) of Dalarna in south-east Sweden. In a way, this lack of a regional style could be seen as both a blessing and a curse: The women of Bohus had a blank slate to embellish, but also a steep road ahead to gain recognition for their efforts.

French paintings, Victorian decorative arts, Peruvian weavings, and Chinese embroideries all influenced the earliest Bohus designs. Large department stores began placing orders for the new designs, which soon included hats, sweaters, and scarves in addition to the socks and mittens offered initially. Emma’s goal—to create a livelihood for the rural women of Bohuslän—was beginning to take off.

The Bohus Stickning organization was run like a well-oiled machine. Emma’s designs were knitted into swatches, charted, and then transported to the rural knitters of the region, who worked both alone and in groups. Each group had a representative who oversaw all of the knitters, taught workshops, scheduled projects, and managed the delivery of yarn packets to the knitters and of finished sweaters back to Bohus Stickning, headquartered at the governor’s residence for many years. Members would come and go, and it was up to the representative to train new members and ensure a quality product. As the endeavor grew, Emma could no longer keep up with design as her administrative duties increased.

Vera Bjurström, who had collaborated with Emma by designing and making the stuffed animals they had experimented with in the early days, became one of the first designers for Bohus Stickning. Vera was joined by Anna-Lisa Mannheimer Lunn, Annika Malmström-Bladini, Kerstin Olsson, and Karin Ivarsson. Together, these six women developed the Bohus style. By the 1950s, Bohus garments were being exported to fine department stores, boutiques, and collectors around the world.

Emma's attention to detail, in terms of both design and materials, cannot be underestimated. All of the yarns were custom-spun blends of only the finest Swedish wool. She paid a higher price for wool to entice shepherds to deliver a clean, quality product worthy of the Bohus Stickning name. Her color selections were the result of careful attention to the French fashion houses, ensuring that the season's upcoming designs were fashion forward. She took a cottage industry and turned it into what we would see today as a thriving design house.

Bohus Stickning was in operation from 1939 until Emma closed it in 1969, when she was eighty-four. Throughout the 1960s, the number of orders for garments had declined. There were many factors beyond Emma's control, including the plagiarism of her designs by companies who could use mass-production methods, the introduction and increasing availability of easy-care fibers such as Orlon, and changing fashion trends. Emma was so unwilling to compromise on quality that even when Neiman Marcus requested sweaters in an Orlon/

mohair blend that was gaining popularity, she outright refused. Her integrity, though it ultimately helped toll the death knell of Bohus Stickning, is admirable.

The designs maintain a lifelong appeal and will always be recognizable as Bohus Stickning. What began as a cottage industry, in many ways, remained such until the end. The women whose lives Emma Jacobsson touched remained loyal to her, many of them working for Bohus Stickning most of the thirty years of its existence. A devotion to quality, to community, and to the craft set Bohus apart—the same values knitters hold to this day. ❁

ABOUT THE AUTHOR AND DESIGNER. Courtney Kelley is the co-owner of Kelbourne Woolens, distributors of The Fibre Company yarns. She graduated from the School of the Art Institute of Chicago in 2001 with a focus in fiber and material studies; her thesis piece was a six-foot (1.8-m) handknitted traditional gansey. A particular love of hers is reading books about the history of knitting and re-creating vintage patterns from photographs and archives—a passion she rarely gets to fulfill in her day-to-day design work. She lives in Philadelphia with her son, two cats, one dog, and six chickens.

A companion project follows

Further Resources

- Keele, Wendy. *Poems of Color: Knitting in the Bohus Tradition*. Loveland, Colorado: Interweave, 1995.
- Lekvall, Lotte. "Hundred Years of Arts and Crafts." *Cultural Entrepreneur*, December 2012.
- Swansen, Meg. *Newsletter #15*. Pittsville, Wisconsin: Schoolhouse Press, October 2011.



The Blue Shimmer, Bohus Stickning's most popular sweater, designed by Anna-Lisa Mannheimer Lunn. Photograph by Joe Coca.

Vävningen Handwarmers

COURTNEY KELLEY

Inspired by the preceding article



These handwarmers are based on a very early Bohus design called *Vävningen*, “The Woven One” or “The Woven Fabric,” which was designed by Bohus Stickning founder Emma Jacobsson. This early design doesn’t incorporate the many colors and purl stitches that are now considered emblematic of Bohus knitting. The earliest designs by Emma often were knit in good quality 100% wool in contrasting shades of natural colors. The Woven One has a pattern reminiscent of the stranded colorwork bands in Fair Isle knitting, but in this instance the bands are running vertically.

Courtney Kelley’s gorgeous Vävningen Handwarmers, inspired by an early design by Bohus Stickning’s founder Emma Jacobsson. Photograph by Joe Coca.

Materials

The Fibre Company Canopy, 50% baby alpaca/30% merino wool/20% bamboo yarn, fingering weight, 200 yards (182.9 m)/50 gram (1.8 oz) skein, 1 skein each of Sarsparilla (MC) and Wild Ginger (CC); www.kelbournewoolens.com

Needles, set of 4 or 5 double pointed, size 0 (2.0 mm) and size 1.5 (2.5 mm) or size needed to obtain gauge

Stitch markers

Waste yarn or stitch holder

Tapestry needle

Finished size: 6¾ inches (17.1 cm) hand circumference and 8 inches (20.3 cm) in length; to fit a woman's small to medium hand

Gauge: 38 sts and 38 rnds = 4 inches (10.2 cm) in charted patt on larger needles

Instructions

Note: See page 124 for Abbreviations and Techniques.

Handwarmer

Cuff,

With MC and smaller needles, CO 64 sts. Divide sts as

evenly as possible on 3 or 4 needles, pm, and join in the rnd. Work in k1, p1 rib for 2½ inches (6.3 cm).

Hand,

Change to larger needles. K 1 rnd. Work Rnds 1–27 of Hand Chart *and at the same time* beg working Thumb Gusset on Rnd 4 foll chart—88 sts.

Rnd 28: Place next 25 sts on waste yarn or holder for thumb, using the backward-loop method and MC, CO 1 st, work in charted patt to end—64 sts.

Work Rnds 29–48 of chart. Change to smaller needles. Cont with MC only. K 1 rnd. Work in k1, p1 rib for ¾ inch (1.9 cm). BO all sts in patt.

Thumb,

Place 25 held thumb sts on 3 or 4 larger needles and join yarns. Foll Vertical Stripe patt as established, work 25 sts, cont in patt, pick up and k 3 sts in gap between hand and thumb—28 sts. Work in patt as established for ¾ inch (1.9 cm). Change to smaller needles. Cont with MC only. K 1 rnd. Work in k1, p1 rib for 4 rnds. Loosely BO all sts in patt.

Finishing

Weave in ends. Block to measurements. ❁

Vertical bands of stranded colorwork in contrasting natural shades are reminiscent of the earliest Bohus designs. Photograph by Joe Coca.



- Key**
- with MC, k
 - with CC, k
 - R with MC, M1R
 - L with MC, M1L
 - R with CC, M1R
 - L with CC, M1L
 - + with MC, CO 1 st
 - no st

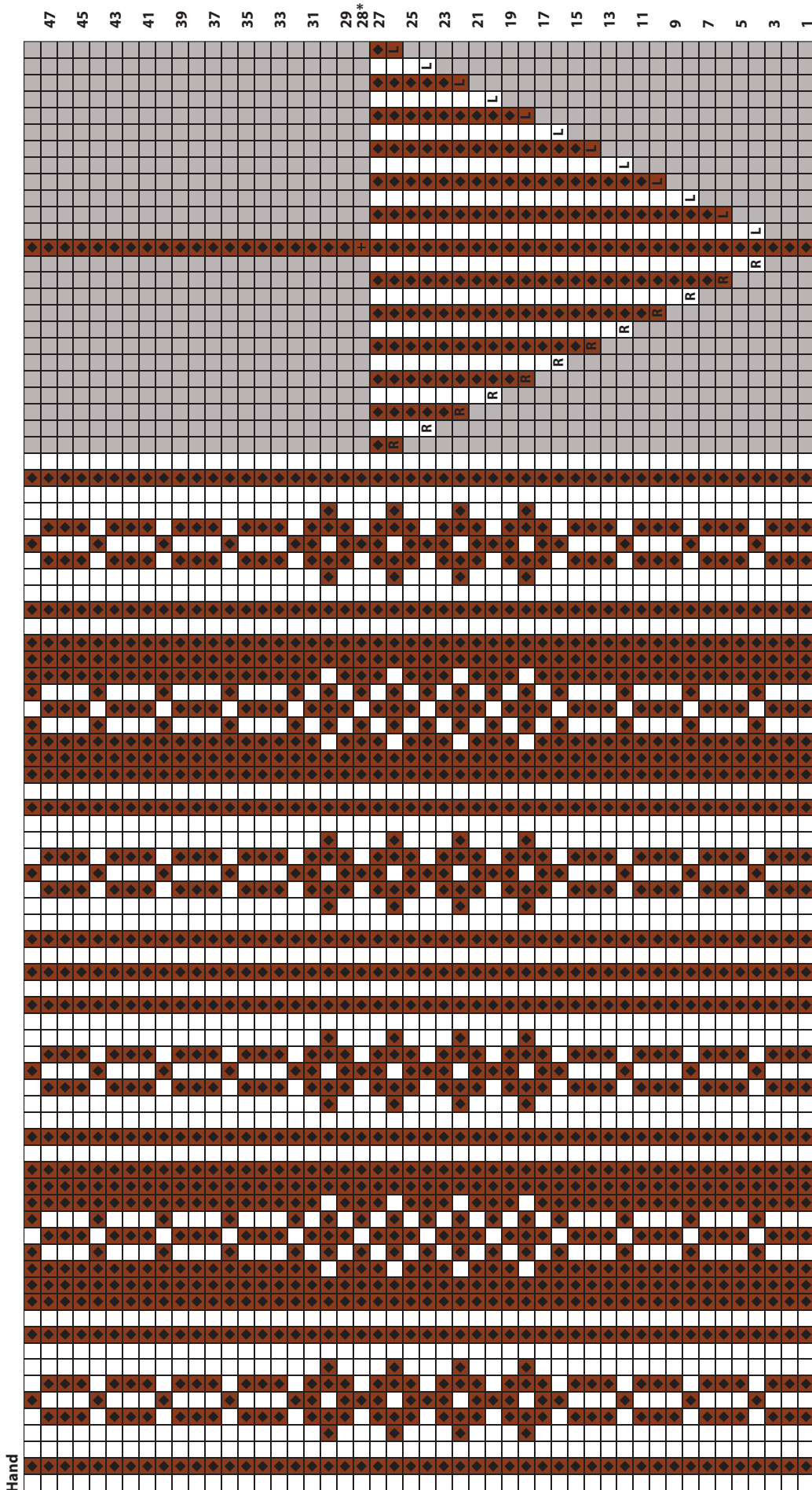

64 to 88 sts

*Work as given in Instructions

Chart may be photocopied for personal use.

The chart for this project is available in PDF format at pieceworkmagazine.com/Charts-Illustrations.

✿ Knitting in Macedonia: ✿ Survival and Creativity

J A S E M I N N A Z I M



A girl knitting an undershirt in Galichnik, west Macedonia. 1948. Photograph by Kiril Bilbilovski and courtesy of the Museum of Macedonia, Skopje, Macedonia.



A bride-to-be with her girlfriends prepares wedding gifts. The girl at right is knitting. Bulachani, Macedonia. 1954. Collection of the Museum of Macedonia. Photograph by Blagoj Drnkov and courtesy of the Museum of Macedonia, Skopje, Macedonia.

In the predominantly rural Macedonian society in the nineteenth and the first half of the twentieth centuries, women processed wool, cotton, flax, hemp, and silk; they spun, wove, sewed, knitted, and embroidered, mostly for their own families and households. The women were from all ethnic groups living in Macedonia—Macedonians, Albanians, Turks, and Vlachs. Some contributed to the household budget by producing clothing for the richer families of their villages or for city dwellers. Others were hired by middlemen—merchants and craftsmen—who supplied them with raw materials and paid them for their work. Some sold their products at specialized women’s markets that were a part of local open markets or at annual regional fairs; sometimes the men of the family, middlemen, and peddlers sold products for them.

In 1878, in Bitola, a merchant of knitted stockings (called *chorab*, a Turkish word used throughout the Balkans; also *chorapi*) appears in the tax registers. The merchant paid lower taxes than the other craftsmen, perhaps because his merchandise wasn’t as profitable. Nevertheless, the existence of a stocking store indicates some

kind of knitting industry at the time. Macedonian folklorist Kuzman Shapkarev, in his 1891 book *Customs, Rituals and Dress*, cited an elderly woman from Ohrid, who described stockings made of white woolen yarn patterned at the toes, heels, and ankles: “The patterns of the stockings today are the following: the toes and heels are



Stanka Dimitrova stands with her display of knitwear at the bazaar in Skopje, Macedonia. 2013. Photograph by and courtesy of the author.

decorated with bright red yarn two fingers wide, followed with one finger wide pattern, made of woolen yarn in various colors. The rest is made of pure white yarn.”

The basic techniques of knitting are almost the same everywhere, but the decoration and the patterns differ in each region to match the rest of the clothing. Stockings are knitted from homespun wool in its natural hue or dyed; cotton or metal threads may be used for decoration. The stockings are worked from the toe up, knitted with three or five small double-pointed metal needles. The yarn is tensioned around the neck. The techniques, the design, and the geometric patterns of traditional Macedonian stockings closely resemble the stockings of Turkish peasants, as well as those of other Balkan peoples who once lived in the Ottoman Empire.

After World War I (1914–1918), Macedonia became a part of the Kingdom of Yugoslavia. In the 1920s, Mili-voe Savich, head of the Yugoslav Ministry of Commerce and Industry, surveyed the country’s economic development. He recorded in some detail a knitting cottage industry in Macedonia, as well as in other parts of Yugoslavia, that employed women to knit wool stockings and undershirts. In the villages near Bitola, he noted that

women knitted for income; in Magarevo and Trnovo, 300 women knitted wool undershirts. In three other vil-lages near Bitola—Malovishte, Gopesh, and Nizepole—women knitted wool stockings. In the city of Krushevo, about 5,000 pairs of woolen stockings were produced yearly; they were sold elsewhere, most likely in Bitola. In the nearby city of Prilep, 2,000 women were knitting stockings and 200 were knitting undershirts. In the city of Veles, 300 women were knitting undershirts.

Between the two world wars, manufactured prod-ucts slowly began to replace handmade knitwear. At the same time, the repertoire of handmade knitwear grew, and new knitting techniques were introduced by fash-ion magazines and women’s schools for handwork. Af-ter World War II (1939–1945), in the new socialist state of Yugoslavia, the government tried to involve women in cottage industries by establishing state cooperatives; women were commissioned to manufacture a variety of handwork and souvenirs, including knitwear. From the 1950s into the 1980s, those who wanted to follow fash-ion trends and couldn’t make their own knitwear sought out knitters who worked independently at home, unreg-istered. The knitters commonly used designs, techniques, and patterns adapted from magazines.



A traditional Macedonian woman's half sleeve for the forearm, designed to be worn under a blouse. Early twentieth century. From the village of Staravina, in central Macedonia. Collection of the Museum of Macedonia. (2928). Photograph courtesy of the Museum of Macedonia, Skopje, Macedonia.

In the late 1970s and early 1980s, it became trendy for young people to wear simple rustic cardigans, vests, and sweaters made from homespun wool. The most popular knitting cooperative in Yugoslavia at the time was from the village of Sirogojno in Serbia. The village's knitters were well organized and cooperated with fashion designers and with the elite fashion wholesale firm Jugoexport, which had retail stores throughout Yugoslavia, including the Macedonian capital, Skopje.

In 1991, Macedonia became an independent country, transforming its socialist system into a capitalist one. The state-owned retail shops of the 1980s gradually were replaced by privately owned shops that began to offer exclusive or trendy clothes for young people, as well as handmade works by artisans. Some of these shops sold handknitted hats, scarves, and sweaters.

In the last twenty years, many Macedonians have lost their jobs, and almost thirty percent of the population, the majority comprised of young people, are unemployed. Some unemployed women have chosen to earn a living through knitting. They organize the work and sell their products in various ways, and they use different techniques and designs. What the knitters have in common is a willingness to work, creativity, enthusiasm, faith in their work, and a determination to make a living from knitting. Each of the women has a story.

Lena Yanakieva, born in 1953, comes from a sheep-breeding family in Eastern Macedonia. She now lives in the city of Veles and after losing her job in 2000, was left with no income and no possibility of finding another job. In 2001, Lena decided to start using the skills she had nurtured since she was a child to earn her living. She began to process wool, spin, knit, weave, and to sell her products at markets. Along with her husband, she washes raw wool that she buys from shepherds in the moun-

tains, then has it machine-carded in Veles. She spins knitting yarn on a spinning wheel and weaving yarn with a spindle. Lena sells slivers of carded wool, skeins of homespun wool, woven woolen sashes, and knitted stockings, slippers, half stockings, vests, and cardigans. She sells during the winter, traveling twice a week from Veles to Skopje. At Bit Pazar, the oldest and biggest open market of Skopje, the sale of her goods covers her basic needs.

Valentina Zdravevska, born in 1971 in Skopje, started knitting for the same reason: she was left jobless in 2001 when the state firm where she worked as a lawyer and a department manager became bankrupt. Unable to find



A women's market in the town of Tetovo, Macedonia, 1958. In the right upper corner, stockings are displayed on the wall. Photograph by Nedelko Vasilev and courtesy of the Museum of Macedonia, Skopje, Macedonia.



Valentina Zdravevska (back right) sells her hand knitted items at the bazaar in Skopje, Macedonia. 2013.

Photograph by and courtesy of the author.

a job in her field, Valentina learned how to knit from an older woman and from YouTube. In 2011, she opened her boutique, Miss Margarida, where she sells her designs of handknitted and crocheted garments. She knits herself but also has seven women working for her.

Katerina Mirkut, a thirty-three-year-old Polish woman with a university degree in Slavic languages, came to Macedonia seven years ago to marry. She couldn't find a job in Macedonia, and meanwhile was knitting and doing other types of handwork, which were her hobbies. Soon, she was producing so much knitwear that she decided to sell her work in boutiques. Eventually, she and some other designers opened a studio where they sell their products. She has her own designer brand, MIKKA.

The three-year project Made in Macedonia had an important role in the development of the handcraft industry in Macedonia. The project was managed by the United States–based nongovernmental organization (NGO) Aid to Artisans (ATA) and funded by the United States Agency for International Development (USAID). ATA has been working in Macedonia since April 2002, helping Macedonian artisans in product development and design, business skills training, development of new markets, and opening retail shops. Since 2005, the effort has been continued by Macedonian Artisans Trade Association (MATA), established by the members of the local staff of ATA. According to Vesna Avramovska, creative director of MATA, the association recruited knitters among the members of women's NGOs in Macedonia.

Several women's associations in Macedonia have cooperated with these organizations, including the Macedonian Housewives Association from Skopje, the NGO Cvet (Flower) from Krushevo, and the Forum of Albanian Women from Tetovo. The bazaars ATA organized encouraged many women to start their own home-knitting industries.

Practical and creative knitting has been providing an income in Macedonia throughout the past two centuries. Let us hope that their successful stories will inspire many other women to take needles and yarn into their skilled hands. ❁

ABOUT THE AUTHOR. *Jasemin Nazim has been a curator for traditional textiles in the Department of Ethnology at the Museum of Macedonia in Skopje since 1982. She has curated and co-curated several exhibitions, including the Ethnology of Macedonia, now a permanent exhibition in the museum. She has published a number of articles about the museum's textile collection, particularly on kilims and archaic Balkan textiles.*

A companion project follows

Further Resources

Cepenkov, Marko. *Makedonski Narodni Umotvorbi* [Macedonian Folklore], Vol. 10, 1900. Reprint, Skopje, Macedonia: Makedonska kniga, 1972. Out of print.

Kuzman, Shapkarev. *Izbrani dela, tom 4, priredil Tome Sazdov, T. Obicai, (Obicai) obredi, nosii.* [Selected Works, Vol. 4, Customs, Rituals and Dress], Skopje, Macedonia: Mislja, 1976. Out of print.

www.matacraft.org.mk

www.mikkadesign.com

Colorwork Hat from Macedonia

STANKA DIMITROVA

Inspired by the preceding article

The Macedonian Cap was inspired by a pair of early-twentieth-century women's half sleeves that are in the collection of the Museum of Macedonia in Skopje, Macedonia. (See photograph on page 79.) I used the traditional motifs from the half sleeves and knitted them into a hat, a popular item in the markets in Skopje.



Stanka Dimitrova's beautiful colorwork hat translates traditional Macedonian motifs into a stylish twenty-first-century hat. Photograph by Joe Coca.

Materials

Lion Brand Wool-Ease, 80% acrylic/20% wool yarn, worsted weight, 197 yards (180.1 m)/85 gram (3.0 oz) ball, 1 ball each of #188 Paprika (A), #138 Cranberry (B), #153 Black (C), #099 Fisherman (D), and #171 Gold (E); www.lionbrand.com

Needles, circular, size 3 (2.75 mm) or size needed to obtain gauge

Finished size: About 21¼ inches (54 cm) circumference and 9½ inches (24 cm) tall

Gauge: 21 sts and 26 rows = 4 inches (10.2 cm) in Chart 2 patt

Special Abbreviation

sk2p—slip 1, knit 2 together, pass slipped stitch over (2 stitches decreased)

Instructions

Note: See above and page 124 for Abbreviations and Techniques.

Hat

With A, CO 100 sts. Pm and join in the rnd.

K 7 rnds.

Picot Rnd: *K2tog, yo; rep from * around.

Work Rnds 1–7 of Chart 1.

Fold brim with WS tog at picot rnd.

Joining Rnd: With A, *pick up 1 st from CO and place on left needle, k2tog; rep from * around.

With A, K 1 rnd.

Inc Rnd: With A, [k8, M1] 12 times, k4—112 sts.

Work Rnds 1–33 of Chart 2.

Cont with D only.

K 4 rnds.

Dec Rnd: [K5, sk2p, k6] 8 times—96 sts rem.

K 3 rnds.

Dec Rnd: [K4, sk2p, k5] 8 times—80 sts rem.

K 3 rnds.

Dec Rnd: [K3, sk2p, k4] 8 times—64 sts rem.

K 3 rnds.

Dec Rnd: [K2, sk2p, k3] 8 times—48 sts rem.

K 3 rnds.

Dec Rnd: [K1, sk2p, k2] 8 times—32 sts rem.

K 3 rnds.

Dec Rnd: [Sk2p, k1] 8 times—16 sts rem.

Break yarn and with tail threaded on the tapestry needle, weave yarn through rem sts, pull tightly and secure on WS.

Finishing

Weave in ends. Block. ❄️

Key

-  Color A
-  Color B
-  Color C
-  Color D
-  Color E
-  patt rep

Chart 1

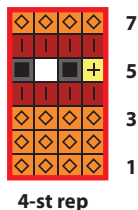

A diamond motif is the central design in Stanka Dimitrova's Colorwork Hat from Macedonia. Photograph by Joe Coca.

Chart 2

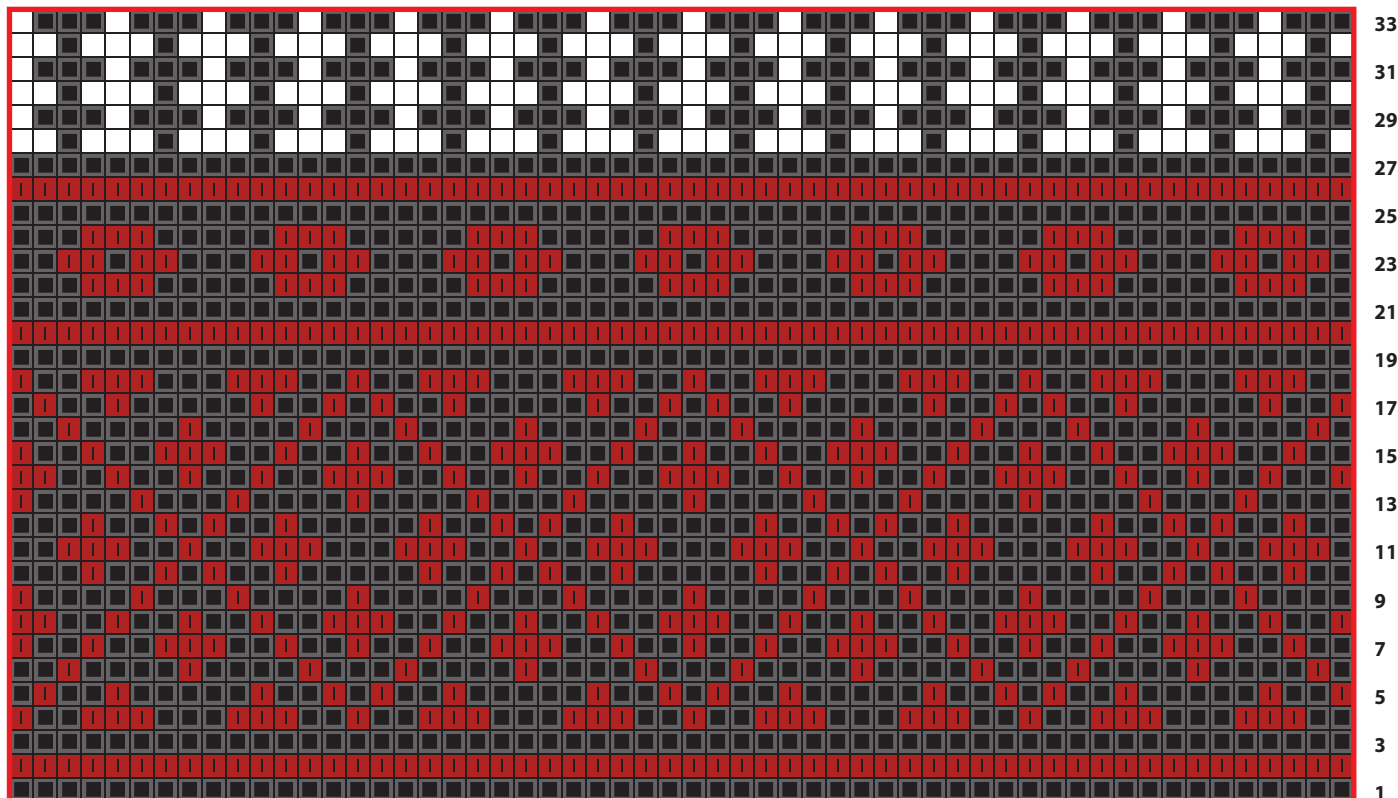

56-st rep

✧ Made for a Prince: ✧ The Sixteenth-Century Stocking Trade

CHRIS LANING



Map of Western Pomerania from the seventeenth century by German mathematician and cartographer, Eilhardus Lubinus. 1635. Map courtesy of Wikimedia.

Among the more famous historical stockings are those discovered in coffins of the Pomeranian Dukes. Duke Barnim the Tenth (1549–1603) was one of several ruling dukes, or princes, of Pomerania, a historic region on the northern Baltic coast, now divided between Germany and Poland. When Duke Barnim died, he was buried at the family castle in Szczecin. In 1946, archaeologists opened the badly damaged coffins of the “Pomeranian Princes,” including that of Duke Barnim.

A pair of silk stockings, possibly Duke Barnim’s, had survived in nearly perfect condition. Now a dark brown, they could well have been originally black. Irena Turnau, an economic historian, speculates that they might be the stockings referred to in the prince’s diary from the

summer of 1600, when he recorded purchasing “*ein Par schwarze seyden gestrichte Strumpfe*” (a pair of black silk knitted stockings).

About 23 inches (58 cm) tall, the stockings would have extended several inches (8 cm) above the knee. This was



A sixteenth-century silk stocking pulled from the coffins of the Pomeranian Princes. Collection of the Muzeum Narodowe w Szczecinie. (MNS/Rz/611). Photograph © the Muzeum Narodowe w Szczecinie, Szczecin, Poland.

typical for the time, when upper-class men's clothing included long, smooth, close-fitting hose worn below short, often puffy, pants. The stockings are knitted in plain stockinette at about 16 stitches per inch (6.3 stitches per cm) and have a common heel, whose heel flap is knitted flat, slightly shaped at the edges (and possibly in the center), then folded in half and seamed. The only decoration appears to be a three-stitch band of purls on each edge of the heel flap.

Where these stockings came from requires some well-informed speculation. Of the millions of stockings knitted between the mid-1500s and mid-1600s, few survive. Most of our information about stocking production and the stocking trade comes from documents that served a variety of purposes—port books, official books of customs rates, and household accounts. These records often don't describe stockings completely, but they at least offer some indication of numbers, types, and markets. Unfortunately, there have been few good statistical studies of the knitting trade so far.

In addition, in the early 1500s, one can't always tell whether the "hose" or stockings mentioned are knitted because the older fashion of stockings cut and sewn from woven wool was still widespread. In fact, cut and sewn

stockings, sometimes called "kersey" continued to be worn alongside knitted ones through the 1600s and beyond. In the 1530s, in England, household accounts occasionally mention "knitte" or "knytt" hose. In the 1540s, those mentions increase, as do discoveries of artifacts, such as the incomplete stocking (often described as a "scogger" or over-sleeve) from the wreck of the Tudor warship, *Mary Rose*, which was built in 1510 and sank in a battle with the French in 1545. This remnant recovered from the ship seems to show the start of a heel.

The late social historian Joan Thirsk (1922–2013) suggested that by the end of the sixteenth century, most people went through two or three pairs of wool stockings per year and multiplied that number by the total population. The result suggests that somewhere between 100,000 and 200,000 knitters worked at least part-time making stockings for sale. Most of these knitters seem to have been from the poorer classes, as also discussed by textile historian Lesley O'Connell Edwards in her extensive history of knitting schools and other schemes set up by towns to encourage poorer women and children to knit. Few and sporadic as they are, censuses from the late 1500s indicate that about a third of the less well-off women and children in some areas of England may have been occupied knitting stockings.

At first, in the 1560s and 1570s, trade records cited by British historian Pauline Croft suggest that most of this trade in stockings was within England. The port records of London show only about 3,500 pairs of stockings being exported in a six-month period in 1576, and nearly all of those were kersey (i.e. not knitted).

Then, between 1598 and 1599, a rather startling change took place: more than 20,000 pairs of knitted stockings began to be exported from London each year, and the leading type of stocking exported was called "worsted." The stockings were high quality knitted from fine yarn that was tightly spun with nearly parallel lengthwise wool fibers. This yarn is different from the softer "woolen" yarn whose fibers run in a variety of directions and trap more air. Spinning and knitting worsted stockings took more skill and resulted in a thinner, but denser stocking. Because worsted stockings were so dense and could be worn for years, they quickly became the preferred style.

The London port books of 1608–1609 cite almost 170,000 pairs of stockings per year being exported from this port alone. At that time, about a third of the stockings exported were kersey, and that number continued to

decline. Nearly half of the stockings exported were worsted, with the remaining stockings mostly knitted from softer woolen yarn. Also by this time, almost half the total stockings exported were children's stockings. This fact suggests that at least in urban areas, many ordinary families no longer knitted all their own stockings, but bought them at markets. During this period, England was the leading producer of worsted stockings in Europe, sending large quantities to the Netherlands, Germany, the Scandinavian countries, and increasingly to Spain and Portugal.

The story of silk stockings begins rather differently. From the beginning, silk stockings were a luxury item, limited to the wealthy, the aristocracy, and royalty. King Henry VIII (1491–1547) had cut and sewn silk stockings, but the “Spanish silk” stockings mentioned in his and Edward VI's (1537–1553) inventories could well have been knitted. Spain had the advantage of excellent steelworks that turned out large numbers of the fine metal needles necessary for knitting very fine stockings.

Knitted silk stockings also were made in France from at least 1560, and in Italy, as the well-known crimson silk burial stockings of Eleonora di Toledo (1522–1562), wife of Cosimo di Medici (1519–1574), suggest. Italy, Spain, and to a lesser extent France continued to be the leading providers of silk stockings for the second half of that century. Trade was brisk: King Erik XIV of Sweden (1533–1577)—Sweden was then a neighbor of Pomerania—had twenty-seven pairs of silk stockings as early as 1566, most of which were sent to him by way of England. A silk stocking foot in the Museum of London also has been dated to about this time.

The high quality of the surviving pieces suggests that skilled and specialized professionals probably made the handknitted silk stockings. Most of the sixteenth and seventeenth-century silk stockings that survive seem to be worked with reeled silk with very little twist. As anyone who has tried to work with this fiber can testify, it's all too easy to split the thread, dull the thread's surface by overhandling, or snag individual fibers while knitting, marring the smooth surface that's one of silk's chief beauties. Silk also has little stretch, requiring careful choice of patterns and especially skillful sizing, shaping, and tailoring to produce stockings that fit without binding or sagging.

Duke Barnim's silk stockings are clearly the product of decades of development in the design and production of knitted stockings. Although plain on the surface, they are subtly shaped for a good fit through the leg, an-

kle, and foot. The foot decoration and the sole gusset are very similar to those of the silk stocking foot in the Museum of London. Knowledge of the high quality of Spanish black dyes and repeated mentions of black silk in the trade records and elsewhere lead us to think they were probably this fashionable color.

If the Duke did buy his stockings about 1600 or a little before, they're likely to have come from either Italy or Spain. Pomerania had excellent trade connections, so the stockings could have been bought either directly or from a secondary source such as Germany, the Netherlands, Sweden, or even England.

We have the Pomeranian prince's stockings because he was a ruler, because he was wealthy enough to afford luxuries, and because he lived at a time when trade was brisk and long-distance transport was thriving. We also have them because after he died, his body was dressed in his best and carefully preserved, and because archaeologists in 1946 chose to open his coffin and preserve his stockings in a museum. We can be grateful that they did. Although trade records can tell us much about life in the sixteen and early seventeenth centuries, the stockings themselves reveal much that we'd never otherwise know. ❀

Further Resources

- Croft, Pauline. “The Rise of the English Stocking Export Trade.” *Textile History*, 18, 1, January 1987.
- O'Connell Edwards, Lesley. “Knitting Schools in Elizabethan England.” *Knitting Traditions*, Spring 2013.
- . “Working Hand Knitters in England from the Sixteenth to the Nineteenth Centuries.” *Textile History*, 41, 1, May 2010.
- Rutt, Richard. *A History of Hand Knitting*. 1987. 2nd ed. Loveland, Colorado: Interweave, 2003.
- Thirsk, Joan. “The Fantastical Folly of Fashion: The English Stocking Knitting Industry, 1500–1700.” In *The Rural Economy of England: Collected Essays*. London: Hambledon Press, 1984.
- Turnau, Irene. “Stockings from the Coffins of the Pomeranian Princes Preserved in the National Museum in Szczecin.” *Textile History*, 8, 1, October 1977.

ABOUT THE AUTHOR. *Chris Laning has been knitting for more than fifty years. She is an independent scholar of medieval knitting and embroidery and is also a historical reenactor known as Dame Christian de Holacombe. As “claning” on Ravelry.com, she sells historical patterns and welcomes comments and questions.*

A companion project follows



Barnim-Style Stockings

ANNE DESMOINES

Inspired by the preceding article

Anne DesMoines's beautiful Renaissance-style stockings inspired by those thought to have been purchased by Duke Barnim the Tenth in 1600. Photograph by Joe Coca.

The stockings worn by the ruling elite in northern Europe from the late 1500s to the early 1600s inspired this pattern. The shaping on the sole of the foot makes this stocking very comfortable to wear and quite attractive. A diamond-shaped gusset on the sole of the foot starts with two stitches at the end of the heel seam and increases to take up the whole width of the sole before the decreases begin for the toe. The increases are compensated for by continuing the instep decreases of the top of the foot all the way to the beginning of the toe, making a neat triangle of what look like “seams” on each side of the foot. Like the construction of the common heel, this is likely an imitation of the sewn seams needed to construct closely fitted stockings from woven material, as was the style before knitted stockings became common.

The stockings left to us to study were generally made of silk at a very fine gauge. The gauge used in this pattern is slightly bigger than that of the fine knit silk of the period. Ribbing substituted for the welting at the top of the knee would take this stocking from the Renaissance straight into the twenty-first century.

Instructions

Notes: See Materials and page 124 for Abbreviations and Techniques. If you are using double-pointed needles, distribute stitches evenly onto four needles, reserving one needle as your working needle. Redistribute stitches as needed when working decreases or heel flap and gusset. If you are using the Magic-Loop method, use half the number of stitches as the back and half as the front.



The diamond-shaped gusset takes up the whole width of the sole before the decreases begin for the toe. Photograph by Joe Coca.

Materials

Cascade Heritage Silk, 85% merino wool/15% mulberry silk yarn, fingering weight, 437 yards (399.6 m)/100 gram (3.5 oz) skein, 2 skeins of #5610 Camel; www.cascadeyarns.com

Needles, set of 5 double pointed or circular 36 to 40 inches (90.0 to 100.0 cm) for Magic-Loop method, size 1 (2.25 mm) or size needed to obtain gauge; 1 extra needle for 3-needle bind off

Stitch markers

Stitch holder

Small yarn needle for finishing

Finished sizes: 12½ (13¾, 16½, 17¾) inches (31.7 [34.9, 41.9, 45.1] cm) cuff circumference; 8 (9, 8, 9) inches (20.3 [22.9, 20.3, 22.9] cm) foot circumference; 18 (21, 25, 28) inches (45.7 [53.3, 63.5, 71.1] cm) long from top of cuff to bottom of heel
Gauge: 36 sts and 48 rnds = 4 inches (10.2 cm) in St st

Special Abbreviation

cbs (center back stitch)—the center back stitch is worked in garter stitch throughout the leg and heel flap

Stocking

Cuff,

CO 112 (124, 148, 160) sts. Pm and join in the rnd. [K 1 row, p 1 row] 3 times for garter welt at top of stocking. The rest of the leg is worked in St st throughout except the 1st st of every rnd: this st is worked in garter st and is referred to as the cbs.

Leg,

Row 1: K.

Row 2: P1, k to end.

Work in patt as established until piece measures 5 inches (12.7 cm) from CO edge.

Dec Rnd: Work cbs, k2tog, k to last 2 sts, ssk—2 sts dec'd.

Rep Dec Rnd every 4th rnd 19 (21, 37, 39) more times—72 (80, 72, 80) sts rem.

Work even until piece measures 15 (18, 22, 25) inches (38.1 [45.7, 55.9, 63.5] cm) from CO edge, ending with the cbs having been worked as a p st.

Next Rnd: Work to last 18 (20, 18, 20) sts, place last 36

(40, 36, 40) sts just worked on holder for instep—36 (40, 36, 40) sts rem for heel.

Heel,

Note: Maintain the center-back stitch throughout the heel flap. Work heel back and forth in rows as follows.

Row 1 (RS): K18 (20, 18, 20), p1, k to end.

Row 2 (WS): P.

Rep last 2 rows until heel flap measures 3 inches (7.6 cm), ending with a WS row.

Shape common heel,

Row 1 (RS): K to 2 sts before cbs, ssk, p1, k2tog, k to end—2 sts dec'd.

Row 2 (WS): P.

Rep last 2 rows 2 more times—30 (34, 30, 34) sts rem.

Next Row (RS): Work to cbs, fold heel flap in half, edge to edge with RS tog, and an equal number of sts on both needles, use 3-needle BO to join heel sts—1 sole st rem.

The heel cup has been formed and now the gusset sts will be picked up along the edges of the heel flap.

Shape gussets,

Next Rnd: With RS facing, pm, pick up and k 27 sts along left edge of heel flap, k 36 (40, 36, 40) instep sts from holder, pm for beg of rnd, pick up and k 27 sts along right edge of heel flap, pm, pick up and k 1 st, work to beg of rnd m—92 (96, 92, 96) sts; 36 (40, 36, 40) instep sts and 56 sole sts.

Notes: There are two stitches between markers on the sole of the foot. The stitches between these markers will be used to form the wedge gusset of the sole. The remainder of the stocking is worked in stockinette stitch.

Rnd 1: Ssk, k to m, sl m, M1, k to m, M1, sl m, k to 2 sts before instep sts, k2tog, k to end.

Rnds 2–4: Ssk, k to 2 sts before instep sts, k2tog, k to end—2 sts dec'd each rnd.

Rep last 4 rnds 2 (1, 2, 1) more time(s), then work Rnds 1–2 (1–3, 1–2, 1–3) once more—72 (80, 72, 80) sts rem; 36 (40, 36, 40) sts each for sole and instep.

Work 2 (1, 2, 1) rnd(s) even. There should be 3 rnds between M1 increase rnd.

Foot,

Next Rnd: Ssk, k to m, sl m, M1, k to m, M1, sl m, k to 2 sts before instep sts, k2tog, k to end.

Work even (no increases or decreases) for 3 rnds.

Rep last 4 rnds until all sole sts are between the m. If needed, work even to desired length of foot minus 2 inches (5.1 cm) for toe shaping.

Shape wedge toe,

Dec Rnd: Ssk, k to 2 sts before instep sts, k2tog, ssk, k to



The center back stitch creates the appearance of a seam in Anne DesMoine's Barnim-style Stocking. Photograph by Joe Coca.

last 2 sts, k2tog—4 sts dec'd.

Rep Dec Rnd every other rnd 11 (13, 11, 13) more times—24 sts rem; 12 each for instep and sole. Use 3-needle BO to join instep and sole sts.

Finishing

Weave in ends.

Garters

If desired, make garters to help hold up the lovely new stockings. CO 6 sts. Work back and forth in garter st (k every row) until piece measures 20 to 23 inches (50.8 to 58.4 cm) long. BO all sts. Weave in ends.

To wear the garters, put the middle of the long garter just under your knee. Take both ends around the back of the knee and back to the front. Tie the garter in the front, just under the kneecap. You can use a flat knot, or half bow to finish the tie. Most people prefer the half bow, as it is easier to adjust as the day wears on. ❁

ABOUT THE DESIGNER. *Anne DesMoines is an avid knitter who loves doing independent research on the history and evolution of knitting. She's been knitting for over fifty years, and her favorite pastime is reproducing knitted artifacts as found in museums, collections, and photographs. She loves to spin and often spins the yarn for her reproductions.*

Love *historical* knitting?

PieceWork Historical Knitting 2007-2010 Collection

This collection includes the first four digital editions of *PieceWork* magazine dedicated to historical knitting.



JANUARY/FEBRUARY 2007:

PieceWork's first issue dedicated to historical knitting features colorful mittens perfect for cold and snow, clever knitted bags, a luxurious sweater for a baby, and tips and techniques for two-end knitting.

JANUARY/FEBRUARY 2008:

PieceWork's second annual historical knitting issue features the popular poetry mittens, ancient Artic knitting techniques, a modern knitted kimono from Ann Budd, and more.

JANUARY/FEBRUARY 2009:

PieceWork's third annual historical knitting issue features Eleanor Roosevelt's love of knitting, tips and techniques to knit a sock in a sock, and instructions to knit Alice Starmore's Capillifolium Baby Bonnet.

JANUARY/FEBRUARY 2010:

Discover fascinating knitters from the past, learn what folks were knitting in medieval London, knit mittens and socks, and enjoy a stitch pattern from Barbara Walker, author of the beloved *Treasury of Knitting Patterns* books.

You can get this Collection on CD or download it instantly at InterweaveStore.com

Working with Wool: A Coast Salish Legacy & the Cowichan Sweater

SYLVIA OLSEN

The following article is adapted from Working with Wool: A Coast Salish Legacy & the Cowichan Sweater (Winlaw, British Columbia: Sononis Press, 2010) with kind permission of the author and publisher.

—Editor

Cowichan sweaters, as they came to be known by the early twentieth century, are a lot like Coast Salish women who knit them: hardy, practical, and enduringly beautiful.



Cowichan woman, wearing a traditional Coast Salish blanket made from mountain goat wool. 1913. Collection of the Edward S. Curtis Collection, Library of Congress Prints and Photographs Division, Washington, D.C (LC-USZ62-118583.) Photograph by Edward S. Curtis and courtesy of the Library of Congress.

Their rugged style and their ability to protect from the damp weather of Vancouver Island, on the west coast of British Columbia, have earned them a place in the hearts of everyone who has worn one on a cold, wet day. Their attractive and readily recognizable patterns turn heads wherever they appear. They are the ingenious creation of the hard-working indigenous women who make them and the favorite outdoor garment of the people who wear them.

The significance of Cowichan sweaters transcends skeins of wool and knitting needles or good-quality outerwear. They are about relationships: between a knitter and a sweater, a sweater and a merchant, a knitter and the person who wears the sweater. Yet the story of the Cowichan sweater reflects an even larger relationship. The sweater's history encompasses the rich and difficult coming together of these two peoples; it represents layers of cultural, social, economic, and human history. The sweaters are a material expression of the junction between two cultures, a fusion or hybridization of European and indigenous art and craft.

The story begins much earlier than the arrival of Europeans and their knitting needles on the west coast of Canada. As the glaciers of the ice age receded, they left fluffy white mountain goats living high in the coastal mountains ranges of the continent. The creation stories of the Cowichan people, whose territory encompasses the mountains and lakes of southern Vancouver Island and the Gulf Islands of the Salish Sea, tell of the first Co-



A Cowichan woman gathers dried wool from the line in preparation for spinning it into yarn. Photograph by Don Coltman and courtesy of City of Vancouver Archives.

wichan woman making wool out of the goat fleece when she appeared to the first man. Her granddaughters, the Coast Salish woolworkers wove the mythical mountain goat wool into heavy and much-prized wool blankets. These blankets were not only highly functional and a staple of trade but were also used in ceremonies and had a value that transcended their intrinsic worth.

In the late nineteenth century, Coast Salish women adopted new technology—the simple knitting needles introduced by Europeans—and used it with their historical art forms and wool-working and basket-making skills to create a unique sweater. These women did not just learn to knit and create one-of-a-kind garments. They created an industry. Coast Salish knitting did not carry the ceremonial or symbolic importance that their weaving had once done, but it brought the knitters fame nationally and internationally and provided an important economic pillar for the community.

In the first decades of the twentieth century, the Coast Salish had a relatively stable and diverse economy. Cash incomes from seasonal work on farms and in mills, fish canneries, and orchards financed necessities for a good life. Knitting provided the extras. Knitters traded their

creations with neighbors for used clothing or farm and garden produce, and sold the rest for extra cash. By the 1920s, Cowichan knitting had developed its own distinct character and was a favorite display item at the Cowichan agency booths at fairs and exhibitions around the world. In the 1920s and 1930s, Cowichan sweaters were one of the most commercially successful native-produced crafts in the country.

But the Great Depression hit indigenous people harder than it did the average Canadian. Indigenous laborers were the first to be laid off when businesses failed and when the economy recovered they were the last to be hired back. With development rapidly impinging on their traditional lands, and shrinking opportunities for traditional food harvesting, Coast Salish people were experiencing poverty in a way they never had before. Knitting, which once supplemented a mixed subsistence and cash income, came to hold a position of primary economic importance, causing the focus of government involvement in the native arts and crafts business to focus on a new imperative of poverty reduction.

Requests to the Indian agents for relief increased. Susan Cooper, from the Songhees reserve near Victoria,



A Cowichan woman shows a sweater for sale in front of her home. 1941–1943. Customers in search of Cowichan sweaters would go from house to house looking for knitwear to purchase. Photograph by Don Coltman and courtesy of City of Vancouver Archives.

had been keeping up with her family's needs by knitting and trading with the local grocery store. In 1933, however, Susan expressed frustration in a note to the Indian agent: "I owe a great deal to the store which I will pay by making sweater[s,] but the store keeper will not let me trade with sweaters for groceries any more after I pay him because he has to[o] many sweaters on hand right now so that is why I am asking you for groceries." Government in-kind relief payments were Susan's only hope. But even with relief she had a hard time feeding her family. At this time Indians received at most four dollars per month in relief payments (less than a quarter of the \$16.50 non-Indians received from the province and municipality), and that was only available under extreme circumstances.

Later that same year Elsie Kamai wrote the agent:

"Please give my mother a pint of milk a day—she is very ill . . . I understand you are buying Indian sweaters. I have one made—the stores in town offer small money for them so I wondered if you could help us—many women in this reserve make them."

In spite of the glut in the market, one sweater could make a knitter as much as an entire month of relief. A Cowichan sweater in this era cost anywhere from \$5–\$25—the same price as a man's suit. It was a lot of money for the buyer and could be good money for the knitter. Elderly knitters recall getting between two and five dollars for their sweaters, depending on the buyer. They got their best deal by selling directly to individual customers, but when business was slow they brought their sweaters to the shops in town, where they generally got about half the retail price. Wool cost about fifty cents a sweater,



A Cowichan knitter displays her work for sale. Date unknown. Photograph G-03197 by Jim Ryan and courtesy of Royal BC Museum, BC Archives, British Columbia, Canada.

leaving the knitter with anywhere from \$1.50 to \$4.50.

While government agents and social reformers were working to market and promote what they saw as authentic native crafts, Coast Salish knitters were developing their own local organic marketing system on reserves throughout Coast Salish territory. When a woman had extra knitting that she didn't need for her family, she hung it on a line outside her house. Customers drove through the reserves, looking to see who had knitting hanging outside—the sign that the knitter was open for business. Individual knitters became known for their particular specialty. Some made great mittens or socks. Some made small sweaters. Others specialized in large sweaters. Thick wool, thin wool, large collars, small collars, white sweaters, busy designs; everyone had their own preference, and knitters had their own styles.

Word got around in the local non-native community about who knit what. This marketing scheme allowed knitters to maintain control over both the quality and quantity of their production. Knitters had first-hand knowledge of what customers were looking for, and customers knew where they could find

what they wanted.

This system worked best for the houses located near traffic, but all knitters took advantage of the road to sell their wares. One Salish woman, Laura, recalled how her stepmother marketed her knitted goods in the days when there was only one road through the reserves, “A long time ago the women used to knit more socks and toques than sweaters. Working people used to like the warm hats and socks. My stepmother used to wrap her knitting in a blanket and take it through the trail from our house up to the road. She set it out on the ground and peddled it right there on the side of the road. She used to sell a lot that way.”

Almost as soon as the settlers started trading with their neighbors for knitting, buyers arrived on the scene, eager to purchase the knitting and sell it for a profit. The first record of someone who may have been a “sweater buyer” appears in the Cowichan Indian agent's records in 1908. Jim Warnock, possibly a local whiskey trader, was reported trading with a Penelekut woman on Kuper Island, northeast of Cowichan. “The somewhat notorious Jim Warnock was visiting the island buying sweaters and

Working with Wool

Sylvia Olsen's book, *Working with Wool: A Coast Salish Legacy & the Cowichan Sweater* (Winlaw, British Columbia, Canada: Sono Nis Press, 2010), tells the stories of this knitting tradition and its knitters. The 328-page hardcover well-documented and -researched book is filled with rich detail of the economic and cultural history of the Coast Salish people.

mats from 'Old sick Jim's Wife' and rather than paying her brings her whiskey. However, if that isn't enough he doesn't even leave her the whiskey, but stays and drinks it with her before returning with the sweaters and mats. It seems some in the community did not want the buyer to return to the Island." There is no indication of what Warnock did with the sweaters or whether he was a regular buyer, but it appears that "Old sick Jim's wife" was satisfied with the whiskey deal and did not want the protection of the agent, nor did she want the community regulating her business.

Unsavory as this particular dealer's ethics were, traders like Warnock played an important role in the early distribution of the Cowichan sweater. They took knitting on the road. Transportation wasn't what it is today, and most knitters lived off the beaten track, so sweater buyers who brought sweaters to customers and returned cash to isolated Coast Salish communities provided a necessary service.

Commercialization rolled into Indian country like a slow moving train and picked up knitting along the way. While it started with those individual deals made on the side of the road and small-scale distribution, by the 1920s local general stores had started trading canned food, household items, and clothing for knitting. Most knitters were familiar with the idea of bartering their sweaters, and it would have been convenient to make a one-stop business transaction on their regular visits to a favorite store. A display of Cowichan knitting became a common sight in the corner of a window at these stores, and it wasn't long before shopkeepers became Indian sweater dealers.

Throughout the 1930s and 1940s, rather than promoting native business, government agents fell into business themselves—buying and selling sweaters. Some agents

were more enthusiastic than others, but they all took part, in one way or another, in finding new markets that would reduce the knitters' dependence on relief. In the late 1930s an agent would pay \$7.50 for a sweater—almost twice as much as a knitter would get from any store. As a result, knitters looked to the agents more and more, not only as a source for relief but also as buyers. Unfortunately Indian agents weren't very good at selling crafts. When H. Graham, the Cowichan District Indian agent, needed samples, he didn't have money to buy them. That meant the knitters had to wait until the sweaters sold before they got paid. Knitters didn't like that arrangement. Many of them lived hand to mouth and sweaters were normally as good as cash to them.

Agents kept up the practice of scouting markets and sending sample sweaters to shops across the country and overseas to garner sales well into the 1960s, but they vastly curtailed their sweater buying in favor of sending orders to local merchants, where knitters were forced to turn to sell their work.

The women who made the sweaters give the Cowichan sweater story its meaning. I am privileged to know these women. Cecelia is one of them. I was having lunch with her one day in the mid-1990s. We were discussing her career as a knitter; although, she didn't see knitting as a career so much as just what she did every day. Knitting was the way she put food on the table and clothes on her children when both commodities were hard to come by. But knitting, for Cecelia, was also her passion.

She told me about feeding her children dried fish and boiled potatoes and onions for Christmas dinner one particularly desperate winter. It was a meager holiday but her children didn't go hungry. She talked about washing wool outside and knitting all night—her absolute favorite thing to do. Once the kids went to bed and the house was quiet, she would pick up her knitting. In the early days before the 1950s, before hydro wires were strung through the reserve, she had a coal oil lamp for light. If she was out of oil she used candles. Late at night it was quiet—no radio, no TV, no kids, just the gentle clicking of her knitting needles. The repetitive movement of her hands uncluttered her mind and gave her time to reflect. Most nights she stayed up until three or four in the morning, and sometimes later if she needed to finish her sweater. She'd sleep for a few

A collection of Cowichan sweaters for sale. 1942. Photograph by Don Coltman and courtesy of City of Vancouver Archives.



hours and then get up and wash and block the sweater for sale later in the day. That way the kids would have something for supper.

When Cecilia finished telling me her story, she looked up to the ceiling and crinkled her brow. After a few moments of silence she turned back to me with a thoughtful look on her face and said, “We Indians were sure hard workers.” And then she laughed.

A few years ago, I attended an Earth Day celebration and sat behind a young woman who wore a beautifully wrought Cowichan look-alike sweater. I spoke to her afterward and discovered she knew the history of the sweater. She was aware hers wasn’t a “real” Cowichan, but she had an authentic sweater at home that she had bought for \$25 at a second-hand store. I counted five authentic Cowichan sweaters at the event, all old and some tattered. The people who wore them appeared to be in their twenties. Each one I spoke to wore the sweater as a statement of what Cowichan sweaters meant to them. Although they did not know a lot about their sweaters, they knew they had meaning.

They were about an earlier time, when what you wore had something to do with who you were and where you came from. They all knew that their Cowichan sweaters weren’t like their other clothes; the sweaters were about the women who made them, they established a relationship. They wore their sweaters in political solidarity with indigenous peoples’ struggle for survival and for a rightful place in their province. ❁

ABOUT THE AUTHOR AND DESIGNER. *Sylvia Olsen married a Coast Salish man and moved to the Tsartlip First Nation. She was immediately struck by the ingenuity Coast Salish women displayed in their production of Cowichan sweaters, which soon became Sylvia’s passion. She operated a Cowichan sweater shop for sixteen years on the reserve. She is the author of Working with Wool: A Coast Salish Legacy & the Cowichan Sweater (see the sidebar on page 94), twelve books for young people, and filmed a documentary, The Story of the Coast Salish Knitters (Prairie Girl Films and National Film Board of Canada, 2000).*

Two companion projects follow

Salish Fusion Fingerless Gloves and Salish Fusion Toque

SYLVIA OLSEN

Inspired by the preceding article



Sylvia Olsen's eye- and soul-pleasing fingerless gloves and toque inspired by motifs in traditional Cowichan knitwear.
Photograph by Joe Coca.

Salish Fusion brings together elegant ancient motifs, natural colors, modern designs, and wool-working techniques. The Olsen family draws on our background as Coast Salish people and the Cowichan knitting tradition our family has practiced for more than a century.

Salish Fusion use simple geometric shapes and design motifs that have been adopted and adapted by Coast Salish knitters and used on their sweaters. Many of the patterns are ancient shapes found across the globe. Various meanings have been ascribed to these patterns depending on the people, place, and time that they are being used. It is the endurance of these eye- and soul-pleasing shapes that gives Salish Fusion knitwear its enduring appeal.

Salish Fusion Fingerless Gloves Materials

Brooklyn Tweed Shelter, 100% wool yarn, worsted weight, 140 yards (128.0 m)/50 gram (1.8 oz) skein, 1 skein each of #20 Cast Iron (MC) and #32 Snowbound (CC); www.brooklyntweed.net

Needles, set of 4 double pointed, size 8 (5 mm) or size needed to obtain gauge

Stitch marker

Stitch holder

Tapestry needle

Finished sizes: 8 inches (20.3 cm) hand circumference and 11 inches (27.9 cm) long

Gauge: 18 sts and 23 rnds = 4 inches (10.2 cm) in St st



A striking geometric design encircles the Salish fingerless gloves.
Photograph by Joe Coca.

Instructions

Note: See page 124 for Abbreviations and Techniques.

Gloves

With MC, CO 36 sts. Evenly divide on 3 needles, pm, and join in the rnd.

Work 6 rnds in garter st (k 1 rnd, p 1 rnd).

Next 2 Rnds: *With MC, k2, with CC, k1; rep from * around.

Note: Carry unused colors up the side of the work.

With MC, k 1 rnd.

Geometric

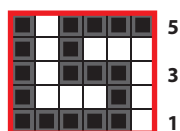

6-st rep

Key

■ MC

□ CC

□ patt rep

With MC, p 2 rnds.

*With CC, k 3 rnds.

Work Rnds 1–5 of Geometric Chart.

With CC, k 3 rnds.

With MC, k 1 rnd.

With MC, p 2 rnds.

Rep from * once more. Break CC.

With MC, work in k1, p1 rib for 8 rnds.

With MC, p 2 rnds.

With CC, k 3 rnds.

Work Rnds 1–5 of Geometric Chart.

With CC, k 3 rnds. Break CC and cont with MC.

Left Glove Only,

Next Rnd: Place 1st 8 sts on holder for thumb, use the cable method to CO 8 sts, k to end.

Right Glove Only,

Next Rnd: K to last 8 sts, place last 8 sts on holder for thumb, use the cable method to CO 8 sts.

Both Gloves,

P 2 rnds.

Next 2 Rnds: *With MC, k2, with CC, k1; rep from * around.

With MC, work 6 rnds in garter st. BO all sts.

Thumb,

Place 8 sts from holder onto needle and join MC.

Next Rnd: K8, pick up and k 7 sts from CO edge—15 sts.

Distribute sts on 3 needles, pm, and join in the rnd.

Next 2 Rnds: P8, k7.

Next 2 Rnds: *With MC, k2, with CC, k1; rep from * around.

With MC, work 6 rnds in garter st. BO all sts.

Finishing

Weave in ends, closing any holes around thumb join. ❁



Traditional Cowichan motifs zigzag across the Salish Toque. Photograph by Joe Coca.

Instructions

Note: See page 124 for Abbreviations and Techniques.

Toque

With cir needle and MC, CO 80 sts. Pm and join in the rnd.

K 9 rnds.

With CC1, k 2 rnds.

With CC2, k 4 rnds.

Work Rnds 1–11 of Toque Chart.

With CC2, k 4 rnds.

With CC1, k 2 rnds.

Crown decreases,

Note: Change to double-pointed needles when necessary.

Change to MC.

Salish Fusion Toque Materials

Imperial Yarn Columbia, 100% wool yarn, 2 ply, worsted weight, 220 yards (201.2 m)/113.4 gram (4.0 oz) skein, 1 skein each of Pearl Gray (MC), Black (CC1), and Natural (CC2); www.imperialyarn.com

Needles, circular, 16 inches (40.0 cm) and set of double pointed, size 9 (5.5 mm) or size needed to obtain gauge

Stitch marker

Tapestry needle

Finished size: 21¼ inches (54.0 cm) brim circumference

Gauge: 15 sts and 20 rnds = 4 inches (10.2 cm) in St st

Next Rnd: [K20, pm] 4 times (using rnd m as last pm).

Dec Rnd: [K to 2 sts before m, k2tog, sl m] 4 times—4 sts dec'd.

Rep Dec Rnd every rnd 18 more times—4 sts rem.

Break yarn leaving a 10-inch (25.4-cm) tail. Thread tail through rem sts and pull to tighten.

Tassel,

Using MC, wind yarn around four fingers 30 times. Thread 10 inches (25.4 cm) of double yarn through the tassel and knot securely. Wind a 6-inch (15.2-cm) length of single yarn around the tassel 8 times, knot and hide the ends. Trim the ends of the tassel. Attach tassel to top of toque. *Note:* I like to knot the tether end 3 or 4 times before I tie it into place at the crown.

Finishing

Weave in ends. ❁

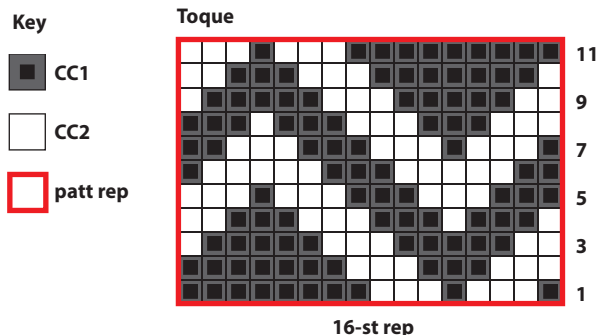

Charts may be photocopied for personal use.

The charts for these projects are available in PDF format at pieceworkmagazine.com/Charts-Illustrations.

❁ Oomingmak Musk Ox ❁ Producers' Cooperative: Qiviut Lace in Alaska

D O N N A D R U C H U N A S

Ten years ago, I first visited Alaska on my quest to learn more about qiviut and the cloudlike handknitted lace made from it. That trip was the start of an adventure that will likely never end for me. It began when I read Janet Catherine Berlo's article in *PieceWork* magazine, "Oomingmak: Knitting Vision into Reality," (January/February 1996). Berlo wrote about a group of native Alaskan women who knitted lace with musk-ox wool. I couldn't believe that the fiber of such a large, funny-looking animal could be made into fine yarn for knitting lace or that women in Alaska would have any reason to knit such lightweight accessories. I wanted to know more.

Oomingmak is the Inupiat word for "musk ox"; it literally means "the bearded one." Qiviut is the down of the Arctic musk ox, a large mammal native to Alaska, Canada, and Greenland. The prehistoric-looking animal has two coats of fur: an outer coat of stiff guard hairs and an inner coat of soft down. The outer guard hairs can grow as long as 2 feet (1.8 m), and can reach almost to the ground, creating a tent under which calves can shelter. The down grows between those long fibers, causing them to stand out from the animal's body, providing insulation against both cold and heat. Qiviut, which is eight times warmer than sheep's wool, is soft, fluffy, and relatively easy to knit with in fine weights because it isn't particularly slippery. It has little luster, and it doesn't felt.

The wild musk ox native to Alaska were hunted to extinction by the middle of the nineteenth century. In the early 1930s, musk ox from Greenland were brought to Alaska in a first attempt at domesticating them. That project was abandoned in 1937, and the animals were released on Nunivak Island where they became wild. During the 1930s



A herd of Arctic musk ox at the Musk Ox Farm in Palmer, Alaska. Photograph by Carl Johnson and courtesy of the Oomingmak Musk Ox Producers' Cooperative.



The first knitters from Mekoryuk on Nunivak Island in a workshop Christmas 1968. From front to back, left to right: Row 1, Nan Kiokun, holding a Marshall scarf; Lincoln Shavings; Mollie Hendricksen; Margie McDonald; Marie Baker. Row 2, Esther Shavings knitting a Mekoryuk scarf; Lydia Weston just casting on; Irene Davis with Nancy Edwards in front; Katie Totkaylook holding a Mekoryuk nachaq; Leah Olrún holding some yarn. Row 3, Susie B. Shavings, Daisy Olrún, Annie Don, Nellie Joshua, Dora John, Neva Hunter, Prudy Olrún, Susie Shavings, Nona Amos, Rose King, and Edith Float. Photograph by Helen Howard. Courtesy of the Oomingmak Musk Ox Producers' Cooperative.



Three members of the Oomingmak Musk Ox Producers' Cooperative. Left to right: Ida, member since 1973; Nellie, member since 1979; Susie, member from 1969-1994. Photograph by Chris Arend and courtesy of the Oomingmak Musk Ox Producers' Cooperative.

and the following decades, the coastal villages of Alaska were extremely impoverished. Most of the native villages had populations of fewer than 200 residents, and work was limited, especially for women. American anthropologist John J. Teal, Jr. (1921–1982) envisioned an opportunity for both the musk ox and the native Alaskans to thrive.

In 1964, after a decade of research into the feasibility of domesticating the animal for its downy undercoat, Teal founded the Musk Ox Project, Alaska's first domestic musk-ox farm. He acquired special permission from the government to capture calves in an attempt to create a captive herd and, ultimately, to domesticate this mammal. The farm was started in Vermont, which was where Teal lived and worked at the time, but his goal was always to have the animals living in rural villages in Alaska, with each native village managing its own herd.

In the late 1970s, Teal transported the herd to Unalakleet, via a temporary location at the University of Fair-

banks, where a new research herd was being developed. Unfortunately, the people of Unalakleet did not want to be musk ox herders. They feared the animals, and they thought the musk ox scared away caribou, a preferred food source. In addition, the field where the musk ox grazed had been a prize berry-picking location. During the winter, it became apparent that the animals would not be able to forage in the deep snow, so they were soon on their way to the Matanuska Valley near Palmer, Alaska, the agricultural center of the state. As the herd grew, qiviut from the animals was combed and spun into exquisite yarn.

In 1968, the Musk Ox Project began to offer workshops to teach native Alaskan women to knit lace. The co-op was born that year when Alaskan textile artist Lillian Schell taught a lace-knitting workshop in the village of Mekoryuk. Many of the women living in the village already knew how to knit, having learned from their

mothers, grandmothers, or friends. Schell was there to teach them how to knit the type of lace that would become the signature style of the cooperative. Over a several day visit, she taught more than twenty women how to knit the Harpoon pattern, which was based on the carving on a 2,000-year-old harpoon head found in Mekoryuk. This original motif was designed jointly by Dorothy Reade, a master spinner and lace knitter from Eugene, Oregon, who worked with Lillian Schell; Sigrun Robertson (who is still the co-op's director); and local members in the earliest days of the cooperative. Those who learned from Schell went on to teach others. Once the co-op was established, members designed additional patterns.

Currently, a group of about 250 native Alaskan members knit lace and colorwork accessories with qiviut yarn; the items are sold in a shop in Anchorage and online (www.qiviut.com). The Oomingmak knitters use all of the qiviut from the animals in the captive herd at the Palmer farm to make their signature products.

Knitting was chosen for the co-op's product line because it's portable, which lets women (and a few men) take their work with them when they travel to fish camps or hunting grounds throughout the year. And the equipment for knitting—simply a pair of knitting needles—is also inexpensive. Lace was chosen because qiviut is so warm and expensive. Knitted lace uses up less yarn than many other types of knitting, and the holes that make up the patterning let the fabric breathe, so it's not suffocatingly warm to wear.

Knitters in each of the original ten villages that joined the co-op in the early years knitted one of the seven original signature patterns. The lace motifs are all based on Yup'ik or Inupiat artwork found in the region where the original villages are—the Yukon-Kuskokwim Delta region on the west coast of the state. The colorwork projects are made by knitters from other parts of Alaska. The knitters in Mekoryuk still knit the Harpoon pattern today, forty-six years after the first workshop was held.

In Unalakleet, a few knitters work the Wolverine Mask pattern, a design based on the traditional carved mask that men wear during ceremonial dances. The mask is one of the rarest patterns co-op knitters use. In Bethel and Quinhagak, knitters work scarves and *nachaqs* (hoods

A Qiviut Primer

How do you pronounce qiviut?

It is pronounced "kiv'-ee-yoot." Alternate spellings are qiviuk and qiviuq. In fact, the spelling "qiviut" is a trademark of the Oomingmak Musk Ox Producers' Cooperative.

What color is qiviut?

The natural color of qiviut is taupe, and the shades vary from light grayish-tan to almost brown, depending on the weather and on where the animals live. Qiviut can be overdyed to create muted and rich tones. When blended with wool, silk, or other naturally white fibers, the blended yarn can be dyed in lighter colors. Qiviut cannot be bleached, however; because the fibers are so fine, they become brittle and break from the chemical process. In fact, qiviut shed in the wild can become brittle and bleached just from lying on the ground, blowing in the wind, or hanging on a fence post exposed to the elements.

How does qiviut compare to other luxury yarns?

Qiviut is one of the most expensive fibers on the market today because of limited availability, high demand, and the difficulty of processing fibers with guard hairs that need to be removed. Here's how some other luxury yarns, most of which are less expensive than qiviut, compare:

Cashmere blooms less than qiviut does, but has more of a "squishy" feel in the hand.

Suri alpaca is smoother than qiviut and drapes with a more relaxed tension. It's also more lustrous than qiviut. It's not as warm, however.

Yak is very soft, as is qiviut, but usually comes only in dark, natural colors. It handles more like alpaca and doesn't form a halo over time.

Bison isn't as soft as qiviut, but has a similar look when blended with merino and silk—again, without the halo.

Guanaco and vicuña yarns from South America are said to be even finer and softer than qiviut, but they're more expensive, rare, and they come only in the natural colors.

—D.D.



Four members of the Oomingmak Musk Ox Producers' Cooperative enjoy working on lace garments knitted with qiviut, fine down from the Musk Ox. Left to right: Mesonga, Margaret, Eliza, and Joyce. Photograph by Chris Arend and courtesy of the Oomingmak Musk Ox Producers' Cooperative.

or “smoke-rings”) using the Butterfly pattern, inspired by the trim on parkas.

Nelson Island knitters work the Diamond pattern, also inspired by parka trim, on scarves, stoles, and nachaqs. In Shishmaref and on the Seward Peninsula, knitters use another rare pattern—a Star motif that mimics the beadwork on a pair of mukluk boots—on scarves.

Only a few knitters have ever made the Dancers pattern from Saint Mary's and Adnreafsky, two villages on different sides of the Adnreafsky River. This pattern represents the motions of women doing traditional dances. On Marshall Island, knitters work the Grass Basket pattern using heavier yarn to create scarves warm enough for those who live in the world's coldest climates. A few other lace designs are knitted as well, and the newer colorwork motifs are reminiscent of Scandinavian knitting patterns.

One wonders if the knitters get bored making the same items over and over again. Although the answer may be yes, it's important to remember that the co-op knitters aren't making qiviut scarves, stoles, and nachaqs for pleasure. Some members knit for personal enjoyment, but when they're making items for the co-op, it's to earn money. Knitters are paid by the stitch, so speed is of the essence. The number of stitches in a scarf, a stole, and a nachaq is constant, so it's easy for knitters to plan how much money they'll make. Those who have been knitting the same pattern for a long time have it memorized—or almost.

Some knitters, such as teenage girls, may make only a few items in a year to earn some spending money. Other women make thousands of dollars a year and have

their knitting in their hands most evenings as they watch television or visit with friends. In many cases, women knit when they need to make a specific purchase. Perhaps their refrigerator breaks down, they need a new boat, or their children need new clothes. They may spend a summer knitting and saving up the money to make the purchase, then take a break until another need for cash arises.

Knitters pay just a few dollars to join the co-op, and they don't have to lay out cash for yarn. Once they've finished a scarf, hat, or other item, they return it to the co-op and, if they want to continue knitting, more yarn is sent to them. When the co-op is profitable, the knitters also earn dividends paid at the end of each year.

After I immersed myself in Alaska's history and native Alaskan art and culture, I knew I wanted to write a book. Two years after I first visited Alaska and met the Oomingmak knitters, I wrote *Arctic Lace: Knitting Projects and Stories Inspired by Alaska's Native Knitters* (Fort Collins, Colorado: Nomad Press, 2006). And I've been discovering more ever since. ❁

ABOUT THE AUTHOR AND DESIGNER. *Donna Druchunas escaped a corporate cubicle to honor her passions for knitting, world travel, research, and writing. She is the author of six knitting books, a contributor to many others, and co-owner, with Ava T. Coleman, of Stories in Stitches, a company offering historically based knitting publications and workshops. Visit her website at www.sheeptoshawl.com.*

A companion project follows

Arctic Tundra Scarf

DONNA DRUCHUNAS

Inspired by the preceding article



100% qiviut yarn made from the down of the Arctic musk ox lends an exquisite luxury to Donna Druchunas's lace scarf. Photograph by Joe Coca.

This scarf reminds me of the landscape of the Arctic tundra, the native home of the musk ox. The color of the yarn and the floral motif make me think of young musk oxen frolicking in the spring, carefree in the warm months while they are growing their own layer of qiviut to protect themselves in the coming winter.

Made from 100% qiviut yarn, the scarf is knit in two pieces. Each piece is worked from the end toward center, and the two ends are joined with Kitchener Stitch.

Materials

Windy Valley Musk Ox Pure Qiviut, 100% qiviut yarn, laceweight, 218 yards (199.3 m)/28.3 gram (1.0 oz) ball, 2 balls of #3002 Forest Floor; www.windyvalleymuskox.net

Needles, size 3 (3.25) or size needed to obtain gauge
Stitch holder
Tapestry needle

Finished size: 8¼ inches (21.0 cm) wide by 69 inches (175.3 cm) long, blocked

Gauge: 26 sts and 32 rows = 4 inches (10.2 cm) in Floral Mesh patt, blocked

Special Stitch

Seed Stitch (over an odd number of sts)

Row 1: K1, *p1, k1; rep from * to end.

Rep Row 1 for patt.

Instructions

Note: See page 124 for Abbreviations and Techniques.

Scarf

*CO 53 sts.

Work in Seed st for ¾ inch (1.9 cm), ending with a WS row.

Next Row (RS): Work Seed st over 4 sts, k to last 4 sts, work Seed st over 4 sts.

Next Row: Work Seed st over 4 sts, p to last 4 sts, work Seed st over 4 sts.

Set-Up Closed Bud Lace,

Next Row (RS): Work Seed st over 4 sts, work Closed Bud Chart over 45 sts, work Seed st over 4 sts.

Next Row: Work Seed st over 4 sts, work Closed Bud Chart over 45 sts, work Seed st over 4 sts.

Work in patt through Row 36 of chart, then work Rows 1–36 once more.

Next Row (RS): Work Seed st over 4 sts, k to last 4 sts, work Seed st over 4 sts.

Next Row: Work Seed st over 4 sts, p to last 4 sts, work Seed st over 4 sts.

Work in Seed st for ¾ inch (1.9 cm), ending with a WS row.

Next Row (RS): Work Seed st over 4 sts, k to last 4 sts, work Seed st over 4 sts.

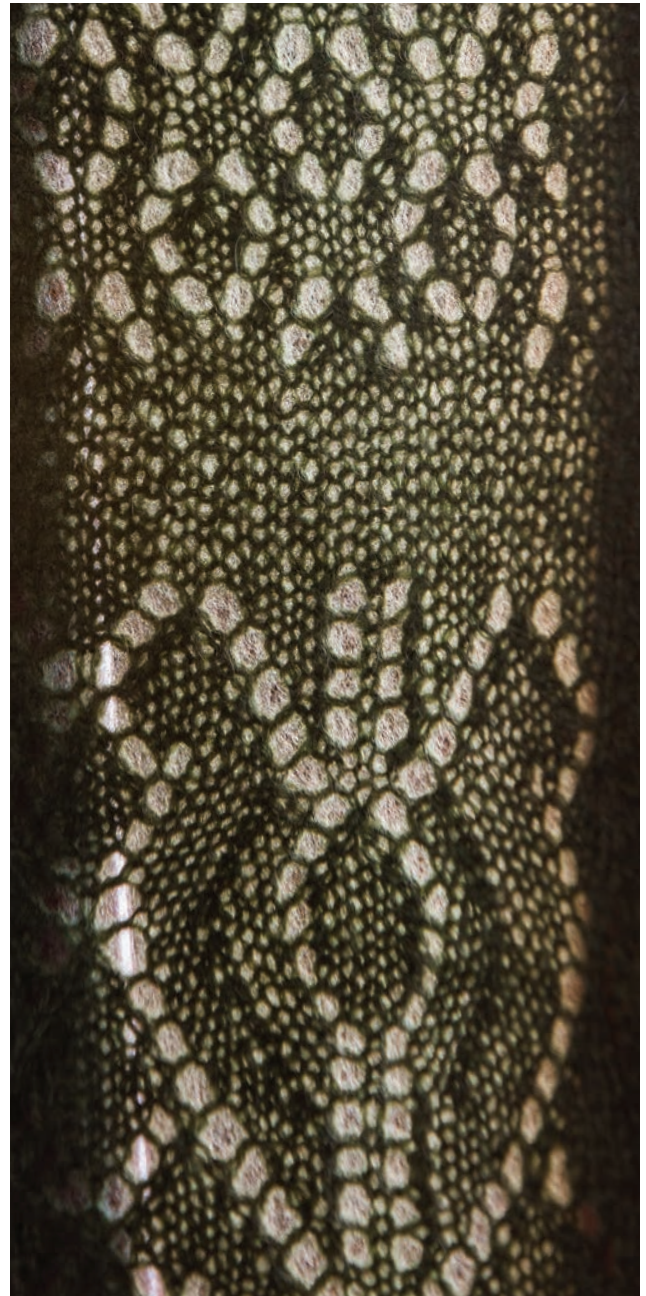

The Closed Bud and Floral Mesh patterns in Donna Druchunas's Arctic Tundra Scarf. Photograph by Joe Coca.

✿ Dainty Work for Profit ✿



In 1894, Addie E. Heron, the editor of *Home Art*, a journal dedicated to interior decoration, published *Fancy Work for Pleasure and Profit* (1894; reprint, Chicago: Thompson & Thomas, 1905). She devotes the last quarter of her book to profiting from fancy work, detailing for her readers how to begin a home business to sell their work. She offers tips for getting started, accepting orders for designs, what to charge and collect, and where to locate their fancy goods stores: “A good field for a lucrative trade may be utterly ruined simply by having the store on the *wrong* side of a street, or because it is located next to some objectionable place, that has been put under the ban of the fair ones of the town.” She details what stock to carry and provides a “List of Desirable Samples,” which includes “One-half dozen doyleys,” “Three center cloths—one square, one round and one long,” and “Three sofa cushions,” among several others.

Items to complete your stock of “desirable samples” shown with Addie Heron’s Fancy Work for Pleasure and Profit. Clockwise from left: Doily No. 1, Knitted Doily, Doily No. 3, Porcupine Stitch, Herring-bone Stripe, Rose Leaf Lace, and Coral Pattern. Photograph by Joe Coca.

We have excerpted portions of her chapter “Dainty Work for Profit” and provided the pattern for the Porcupine Stitch from her book. We’ve also included the Coral Pattern, Rose Leaf Lace, and Herring-bone Stripe from The People’s Handbook Series’ *The Ladies’ Model Fancy Work Manual* (1893, New York: F. M. Lupton) and three doilies from *Needlecraft Magazine*, one from the December 1920 issue and two from the January 1923 issue. The patterns are printed exactly as they appeared in the originals. We hope they set you on your way to contributing to your own family’s exchequer!

“Dainty Work for Profit” is a subject that will appeal to the great army of women in our country who feel the need of adding their mite to the family exchequer, either as a wife, mother, daughter, or sister. These women may be divided into two classes. First: those who have only a limited portion of time to devote to any work outside the regular home duties, and who could not be absent from home for any regularly stated time. Second: those women who have to assume the support of families or portion of families, and whose time must be given to that work, leaving home cares and duties to others. For both these classes there is a note of hope and good cheer in the words “Dainty Work for Profit.”

Stay-at-Homes.

There are hundreds of homes of wealth in the country that have not within them the means of artistic decoration. It may be the mistress has passed the period of life when “fancy work” had a charm, she may be a woman of “ability” who scorns the “little trifles” of life, or it may be the mother and daughters have, by years of pinching economies, helped to upbuild that elegant home of brick and mortar, and so have not had time to give it the home-look of habitations where womanly love and care presides over all departments. It would be unjust to say that the inmates of these bare-looking homes do not desire beautiful pictures, graceful draperies, pretty nick-nacks and all the little touches that help to make the real home. They do desire these things . . . and here is the opportunity for the woman who has a love for making beautiful things, and the time to give to it. She can exchange her brain work, her artistic abilities for the dollars and cents of her wealthier neighbors by taking orders for making their homes beautiful, “and filling them within the shelter of her own home.”

Art Bazaars or Fancy Good Stores.

We come now to the second class of women, who need to earn money, and have an inclination to turn

their energies to interior decoration and art needlework. For such the “Art Emporium,” “Fancy Goods Bazaar,” or “Decorative Art Store” offer a field that well repays careful cultivation.

The first consideration for such a departure is that of Capital, usually, a word of discouraging import to women of ambition, as so few women ever have anything except brain, energy, pluck, faith and hope, to work with; but even the want of capital can, in a measure, be overcome by good business ability. Of course there must be some ready money, but the amount actually necessary can be brought down to quite modest proportions, provided, always, one knows how to go to work, and has a good reputation at home for integrity and honesty of purpose in all the relations of life.

Materials

These are the materials our knitters used.

Coral Pattern

Presencia Fincrochet 100% cotton thread, size 10, 383 yards (350.2 m)/20 gram (0.7 oz) ball, 1 ball of #0001 White; www.presenciaamerica.com; needles, size 0 (2.0 mm)

Doily No.1

Louet 14/2 Euroflax Linen, 100% linen thread, laceweight, 580 yards (530.4 m)/100 gram (3.5 oz) skein, 1 skein of Terra Cotta #2472; www.louet.com; needles, size 2 (3 mm)

Doily No. 3

Norsk Engros 50/2-H, 100% linen thread, 300 yards (274.3 m)/20 gram (.07 oz) ball; 1 ball of White; www.needlestack.com; needles, size 2 (3 mm)

Herring-bone Stripe

Fyberspates Scrumptious Lace, 45% silk/55% merino yarn, laceweight, 1,093 yards (999.4 m)/100 gram (3.5 oz) hank, 1 hank of #504 Water; www.fyberspates.co.uk; needles, size 0 (2.0 mm)

Knitted Doily

Louet 14/2 Euroflax Linen, 100% linen thread, laceweight, 580 yards (530.4 m)/100 gram (3.5 oz) skein, 1 skein of Golden Rod # 2652; www.louet.com; needles, size 2 (3 mm)

Porcupine Stitch

Whisper Lace, 70% wool/30% silk yarn, laceweight, 440 yards (402.3 m)/50 gram (1.8 oz) skein; www.universalyarn.com; needles, size 0 (2.0 mm)

Rose Leaf Lace

Louet Euroflax 100% linen yarn, sportweight, 270 yards (246.9 m)/100 gram (3.5 oz) skein, 1 skein of #55 Willow; www.louet.com; HiyaHiya needles, circular, 11 inches (27.9 cm), size 00 (1.75 mm) stainless steel; www.hiyahiyanorthamerica.com



Recommended fancy work items to sell. Left to right: Karen Brock knitted the Herring-bone Stripe and Porcupine Stitch; Whitney Dorband knitted the Rose Leaf Lace and Coral Pattern. Photograph by Joe Coca.

Porcupine Stitch

By Addie E. Heron

Fancy Work for Pleasure and Profit

Cast on in twelves. 1st row, plain.

2nd row, * over, k. 2 together, repeat from *.

3rd row, purl; 4th row, plain; 5th row, purl.

6th row, sl. 1, k. 2 together, pass the slipped stitch over, k. 4, over, k. 1, over, k. 4; repeat.

7th row, p. 3 together, p. 4, over, p.1, over, p. 4; repeat.

8th row, like 7th; 9th row, like 6th; 10th row, like 7th.

Repeat from second row. Very pretty.

Herring-bone Stripe

The Ladies' Model Fancy Work Manual

CAST on any number of stitches divisible by three.

1st row—Knit one, knit two together, make one.

Repeat. End the row with knit two.

2nd row—Purl one, purl two together, make one. Repeat. End the row with purl two.

These two rows are repeated throughout.

Coral Pattern

The Ladies' Model Fancy Work Manual

CAST on any number of stitches divisible by twenty-one.

1st Row—Knit two together, knit three, knit two together, knit one, make one, knit one, make one, knit

one, knit two together, knit three, knit two together, knit one, make one, knit one, make one, knit two.

2nd Row—Purl.

3rd Row—Knit two together, knit one, knit two together, knit one, make one, knit three, make one, knit one, knit two together, knit one, knit two together, knit one, make one, knit three, make one, knit two.

4th Row—Purl.

5th Row—Slip one, knit two together, pass the slip stitch over, knit one, make one, knit five, make one, knit one, slip one, knit two together, pass the slip stitch over, knit one, make one, knit five, make one, knit two.

6th Row—Purl.

7th Row—Knit two, make one, knit one, make one, knit one, knit two together, knit three, knit two together, knit one, make one, knit one, make one, knit one, knit two together, knit three, knit two together.

8th Row—Purl.

9th Row—Knit two, make one, knit three, make one, knit one, knit two together, knit one, knit two together, knit one, make one, knit three, make one, knit one, knit two together, knit one, knit two together.

10th Row—Purl.

11th Row—Knit two, make one, knit five, make one, knit one, slip one, knit two together, pass the slip stitch over, knit one, make one, knit five, make one, knit one, slip one, knit two together, pass the slip stitch over. Repeat from the first row.

Rose Leaf Lace

The Ladies' Model Fancy Work Manual

CAST on 31 stitches, knit across plain.

1. S. 1, k. 2, t. t. o. twice, p. 2 together, k. 1, n. k. 2, t. t. o., k. 1, t. t. o., n., t. t. o., n., t. t. o., k. 2, n. k. 4, n., k. 2, t. t. o., k. 1, t. t. o., n., t. t. o., k., 1.

2. P. all stitches except last 5, then t. t. o. twice, p. 2 together, k. 3.

3. S. 1, k. 2, t. t. o. twice, p. 2 together, k. 2, n., t. t. o., k. 3, t. t. o., n., t. t. o., n., t. t. o., k. 2, n., k. 2, n., k. 2, t. t. o., k. 3, t. t. o., n., t. t. o., k. 1.

4. Like 2d. (All even rows like 2d.)

5. S. 1, k. 2, t. t. o. twice, p. 2 together, k. 1, n., t. t. o., k. 5, t. t. o., n., t. t. o., n., t. t. o., k. 2, n., n., k. 2, t. t. o., k. 5, t. t. o., n., t. t. o., k. 1.

7. S. 1, k. 2, t. t. o. twice, p. 2 together, k. 4, n., k. 2, t. t. o., n., t. t. o., k. 1., t. t. o., k. 1, t. t. o., k. 2, n., k. 2, n., k. 1, n., k. 2, t. t. o., n., t. t. o., n.

9. S. 1, k. 2, t. t. o. twice, p. 2 together, k. 3, n., k. 2, t. t. o., n., t. t. o., n., t. t. o., k. 3, t. t. o., k. 2, n., k. 2, n., k. 2, t. t. o., n., t. t. o., n.

11. S. 1, k. 2, t. t. o. twice, p. 2 together, k. 2, n., k. 2, t. t. o., n., t. t. o., n., t. t. o., k. 5, t. t. o., k. 2, n., n., k. 2, t. t. o., n., t. t. o., n.

Knitted Doily By Frieda Bettex

Needlecraft Magazine December 1920

THE doily is begun at the center.

Cast on 9 stitches.

1. Knit plain, using 3 needles and putting 3 stitches on each needle; join.

2. Knit plain; all even rows the same, unless otherwise directed.

3, 5. Over, knit 1; repeat.

7. Over twice, narrow; repeat.

8. Like 2d, purling the 2d of the “over-twice” loops where these occur.

9. Knit 1st stitch and slip it over on last needle of 8th row, doing this at the beginning of each needle of 9th row; then * over twice, slip, narrow and bind; repeat.

11. Like 9th; you should now have 18 stitches on each needle.

13. Knit plain.

15. Over, knit 9; repeat.

17. Knit 1, over, knit 9, over; repeat.

19. Knit 2, over, slip 1, knit 1, bind slipped stitch over, knit 5, narrow, over, knit 1; repeat.

21. Knit 3, over, slip and bind, knit 3, narrow, over, knit 2; repeat.

23. Knit 4, over, slip and bind, knit 1, narrow, over, knit 3; repeat.

25. Knit 5, over twice, slip, narrow and bind, over twice, knit 4; repeat.

27. Knit 5, over twice, knit 1, over, slip, narrow and bind, over, knit 1, over twice, knit 4; repeat.

29. Knit 3, narrow, over twice, knit 3, over, slip, narrow and bind, over, knit 3, over twice, slip and bind, knit 2; repeat.

31. Knit 2, narrow, over twice, knit 5, over, slip, narrow and bind, over, knit 5, over twice, slip and bind, knit 1; repeat.

33. Knit 1, narrow, over twice, knit 7, over, knit 3, over, knit 7, over twice, slip and bind; repeat.

35. Before starting 35th row slip last stitch of 34th row

over on 1st needle of 35th row, then slip, narrow and bind, over twice, knit 9, over, narrow, over twice, slip and bind, knit 1, over, knit 9, over twice; repeat.

36. Knit 10, narrow, over, knit 7, over, slip and bind, knit 9; repeat.

37. Knit 9, narrow, over, slip and bind, over twice, slip and bind, narrow, over twice, slip and bind, knit 1, over, slip and bind, knit 8; repeat.

38. Knit 8, narrow, over, knit 11, over, slip and bind, knit 7; repeat.

39. Knit 7, narrow, over, slip and bind, over twice, (slip and bind, narrow, over twice) twice, slip and bind, knit 1, over, slip and bind, knit 6; repeat.

40. Knit 6, narrow, over, knit 15, over, slip and bind, knit 5; repeat.

41. Knit 5, narrow, over, slip and bind, (over twice, slip and bind, narrow) 3 times, over twice, slip and bind, knit 1, over, slip and bind, knit 4; repeat.

42. Knit 4, narrow, over, knit 19, over, slip and bind, knit 3; repeat.

43. Knit 3, narrow, over, slip and bind, (over twice, slip and bind, narrow) 4 times, over twice, slip and bind, knit 1, over, slip and bind, knit 2; repeat.

44. Knit 2, narrow, over, knit 23, over, slip and bind, knit 1; repeat.

45. Knit 1, narrow, over, slip and bind, over twice, (slip and bind, narrow, over twice) 5 times, slip and bind, knit 1, over, slip and bind.

46. Use as 1st stitch the last stitch of preceding row, slip, narrow and bind, over, knit 27, over; repeat.

47. Slip and bind, narrow, over twice; repeat.

48, 50, 52, 54. Knit plain.

49, 51. Purl.

53. Slip and bind, * over twice, slip and bind, narrow; repeat.

55. Over, * slip and bind, narrow, over twice; repeat, ending with 1 “over.”

56. Knit plain, but making 5 stitches of every “over-twice” loop by alternately knitting and purling—that is, knit 1, purl 1, knit 1, purl 1, knit 1.

57, 59. Purl.

60. Knit plain.

Bind off loosely, so that the edge will not draw. Baste the doily on a towel folded three or four times, being careful to have the circle perfect and the points or scallops of the outer edge even. Rinse in lukewarm water and let dry without ironing. Stretch the doily in basting.



Ava Coleman knitted three exquisite lace doilies in linen thread. Left to right: Doily No. 1, Knitted Doily, and Doily No. 3. Photograph by Joe Coca.

Knitted Doilies By Frieda Bettex

Needlecraft Magazine January 1923

Two needles are used in knitting these doilies, which will be found very desirable for many uses, and will make the nicest of gifts to those who enjoy the possession of articles in this new-old variety of thread lace. Any size of thread may be chosen; the coarser it is, of course, the larger will be the doilies. Needles should be of a size suited to the thread. It is an excellent plan to first knit a sample gore or section, from which may be judged results. Methods of knitting vary greatly, some workers requiring larger or smaller needles, because their work is done more tightly or loosely, as the case may be.

No. 1—Cast on 26 stitches and knit once across plain.

1. Slip 1, knit 2, (over, narrow) 10 times, over, knit 3.
3. Be careful to have the slipped stitches on the outer edge rather loose.
2. Slip 1, knit 24, turn, leaving 2 on needle.
- 3, 5. Slip 1, knit 21, over, knit 3.
4. Slip 1, knit 24, leave 3.
6. Slip 1, knit 24, leave 4.
7. Like 3d row.
8. Slip 1, knit 23, leave 6.
9. Slip 1, knit 20, over, knit 3.
10. Slip 1, knit 22, leave 8.
11. Slip 1, knit 19, over, knit 3.
12. Slip 1, knit 21, leave 10.
13. Slip 1, knit 15, narrow, over, narrow, knit 2.
14. Slip 1, knit 18, leave 12.

15. Slip 1, knit 12, narrow, over, narrow, knit 2.
16. Slip 1, knit 15, leave 14.
17. Slip 1, knit 9, narrow, over, narrow, knit 2.
18. Slip 1, knit 12, leave 16.
19. Slip 1, knit 6, narrow, over, narrow, knit 2.
20. Slip 1, knit 9, leave 18.
21. Slip 1, knit 3, narrow, over, narrow, knit 2.
22. Slip 1, knit 6, leave 20.
23. Slip 1, narrow, over, narrow, knit 2.
24. Slip 1, knit 25.

This completes one section. Repeat from 1st row until you have completed twelve sections, then bind off rather loosely, sew up the open side evenly and draw the center together as closely as possible. Then stretch the doily on a board with pins or thumb-tacks, or sew to a cloth stretched in an embroidery frame, drawing the points out as evenly and as much as you can, wet it and leave until perfectly dry; it will then lie flat and smooth. I imagine this doily would be very pretty to use as a cushion-cover knitted in white or cream-colored silk; one could then make a row of French knots on the outer edge, just a little inside the border, with green, and a small flower in loop- or daisy-stitch in the widest part of each section and at the center—the flower of light blue, perhaps, with a center of yellow. Or this part of the work could be done with beads. The doily may be made larger by casting on more stitches to begin with, and working a greater number of rows according to the directions given.

Cast on as you bind off, rather loosely.

No. 3—Knit like No. 1 until you have completed the 6th row.

7. Slip 1, knit 5, (narrow, over twice, narrow, knit 4) twice, over, knit 3.
 8. Slip 1, knit 9, purl 1, knit 7, purl 1, knit 5, leave 6.
 9. Slip 1, knit 9, (narrow, over twice, narrow) twice, knit 3, over, knit 3.
 10. Slip 1, knit 8, purl 1, knit 3, purl 1, knit 9, leave 8.
 11. Slip 1, knit 9, narrow, over twice, narrow, knit 6, over, knit 3.
 12. Slip 1, knit 11, purl 1, knit 9, leave 10.
 13. Slip 1, knit 5, (narrow, over twice, narrow) twice, knit 2, narrow, over, narrow, knit 2.
 14. Slip 1, knit 8, purl 1, knit 3, purl 1, knit 5, leave 12.
 15. Slip 1, knit 5, narrow, over twice, narrow, knit 3, narrow, over, narrow, knit 2.
 16. Slip 1, knit 9, purl 1, knit 5, leave 14.
- Knit the remainder and finish like No. 1. ❀

EXCLUSIVE OFFER now at InterweaveStore.com

ENJOY **10% OFF** educational products, resources, projects and more – enter code **NEEDLEPUB10** at check-out and save 10% off select products.

**SAVE
10%**
Off Your Next
Purchase

No minimum order
and no end date.



From the same great providers of education, articles and inspiration you experience reading *PieceWork*, check out InterweaveStore.com/needlework and save now!

Promo Code Exclusions Apply: Your special discount/coupon code will allow you to take 10% OFF many (not all) of the items you find at InterweaveStore.com/needlework. Your discount/coupon code is not valid for purchasing gift cards, subscriptions, pre-orders, value packs, VIP memberships, or items that ship directly from manufacturers. Discounts cannot be applied to previous purchases. Valid for one use per customer only. Other exclusions may apply.

✿ Ancestral Memory: ✿ Knitting in the Shadow of Mount Ausangate

L I N D A L I G O N

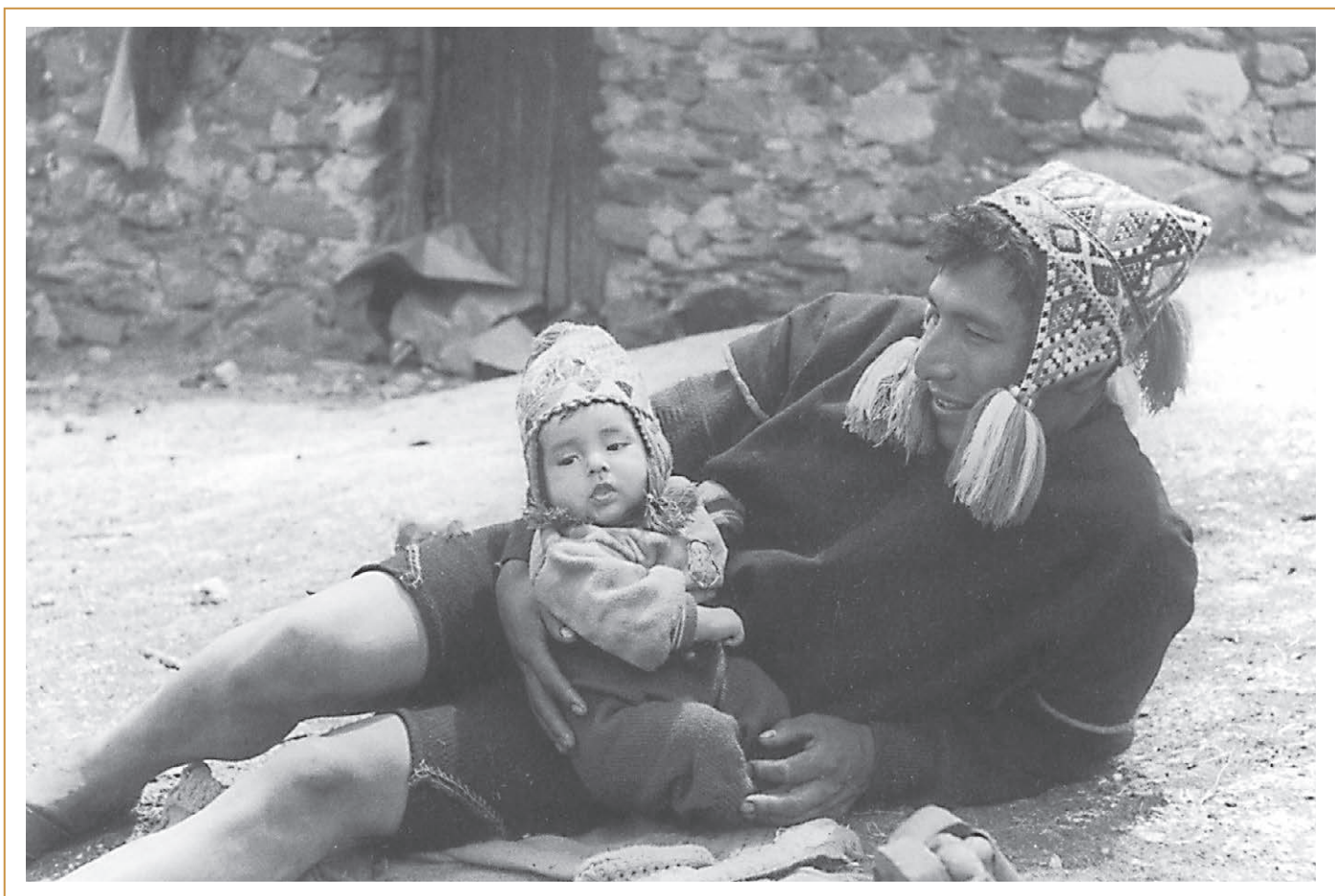

Juan Quispe Calcinas and son, both wearing proper handspun, handknit chullos. Photograph by John Cohen.

Mount Ausangate is a giant among mountains, rising to 21,000 feet (6,400.8 m) in the Cusco District of southeastern Peru. Mountains in Peru are much more than geographical features; they are gods of the earth—*Apus*. Mount Ausangate is regarded as perhaps the strongest apu, the most significant, the most central to the lives of the Quechua Indians who live within its far-reaching influence.

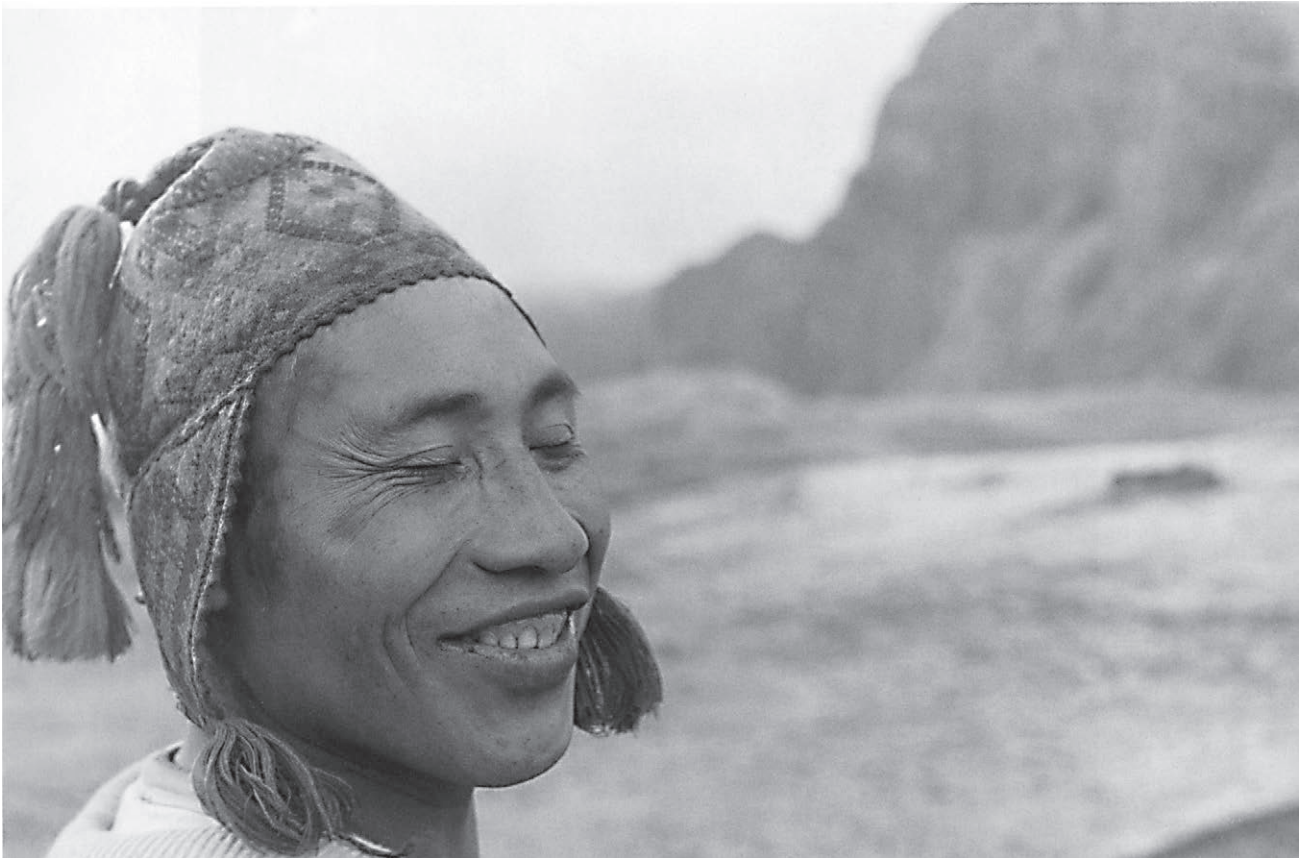

Raymundo Quispe Chura in 1983, when he was thirty-three years old. Raymundo became an important shaman in his community.
Photograph by John Cohen.

Thousands of Quechua, descendants of the Incas, make a tortuous pilgrimage—*Q'ollu Riti* or “Snow Star”—to the heights of Mount Ausangate each year. Led by ritual dancers and all manner of music, the people trek to the very edge of the once-vast glacier that caps the mountain, seeking intercession from the apu for their hopes and dreams. It is a frigid, grueling experience, but one filled with reverence and joy.

The Ausangate region is home to herds of llamas and alpacas, who prefer a high, cold environment. In Q'eros, in the far north, and Ocongate, to the northwest, harvesting these camelid fibers, spinning, and knitting them are important activities for cultural and economic reasons. Virtually every man in these regions wears a handknit *chullo* (hat with earflaps) often topped by a felt fedora-style hat to protect from the sun. More often than not,



Left: A Q'eros family in 1957. Father and son wear traditional chullos (hat with earflaps) and handwoven ponchos. Photograph by John Cohen.

Below: Raymundo Quispe Chura in 2005. He is preparing to offer a bundle of sacred objects as a burnt offering in his role of shaman. Photograph by John Cohen.

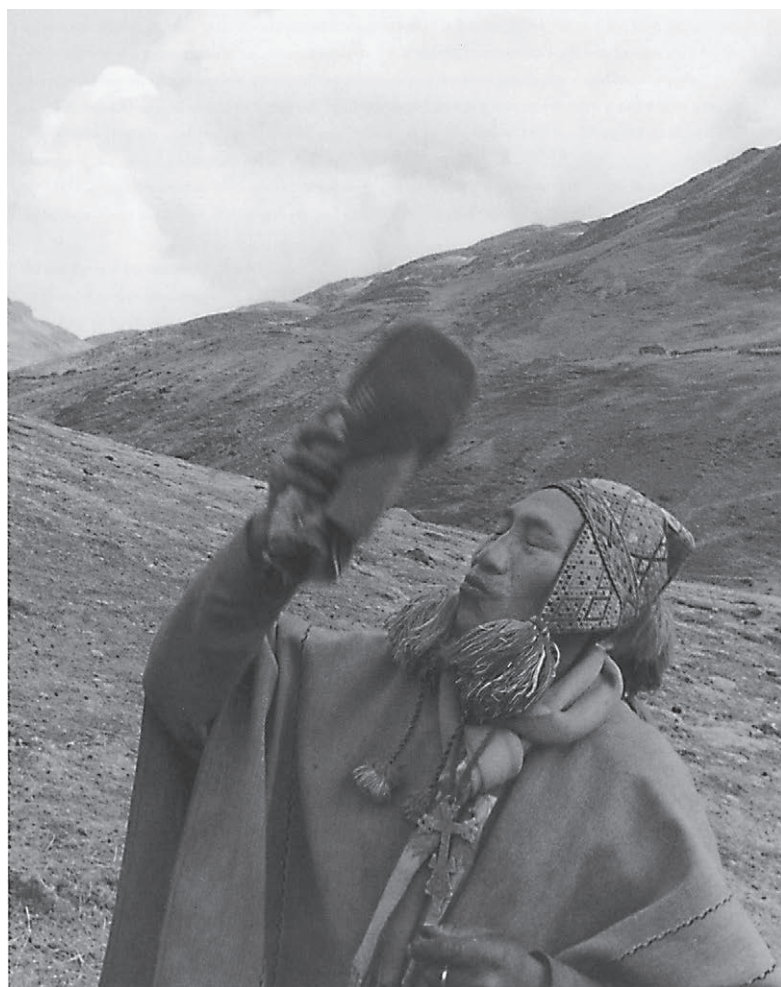

the man will have knit his own chullo, and he will have knit little caps for his sons as well. In older generations, the chullos were patterned in natural colors. Now, for festive occasions—community gatherings, traditional rituals, saints' days—there are special hats often made with bright, almost gaudy, colors of synthetic or naturally dyed yarns, often elaborately embellished with buttons and beads. Today, some men knit their intricately patterned hats for sale, resulting in preservation of the tradition and a small supplement to their scanty income.

Photographer, filmmaker, and musician John Cohen traveled extensively in the Ausangate region, particularly among the Q'eros, from the 1950s through the 1990s.

They seem to hold an ancestral memory of the geometry and mathematics of a proper chullo and its patterning. Yet they never knit two alike.

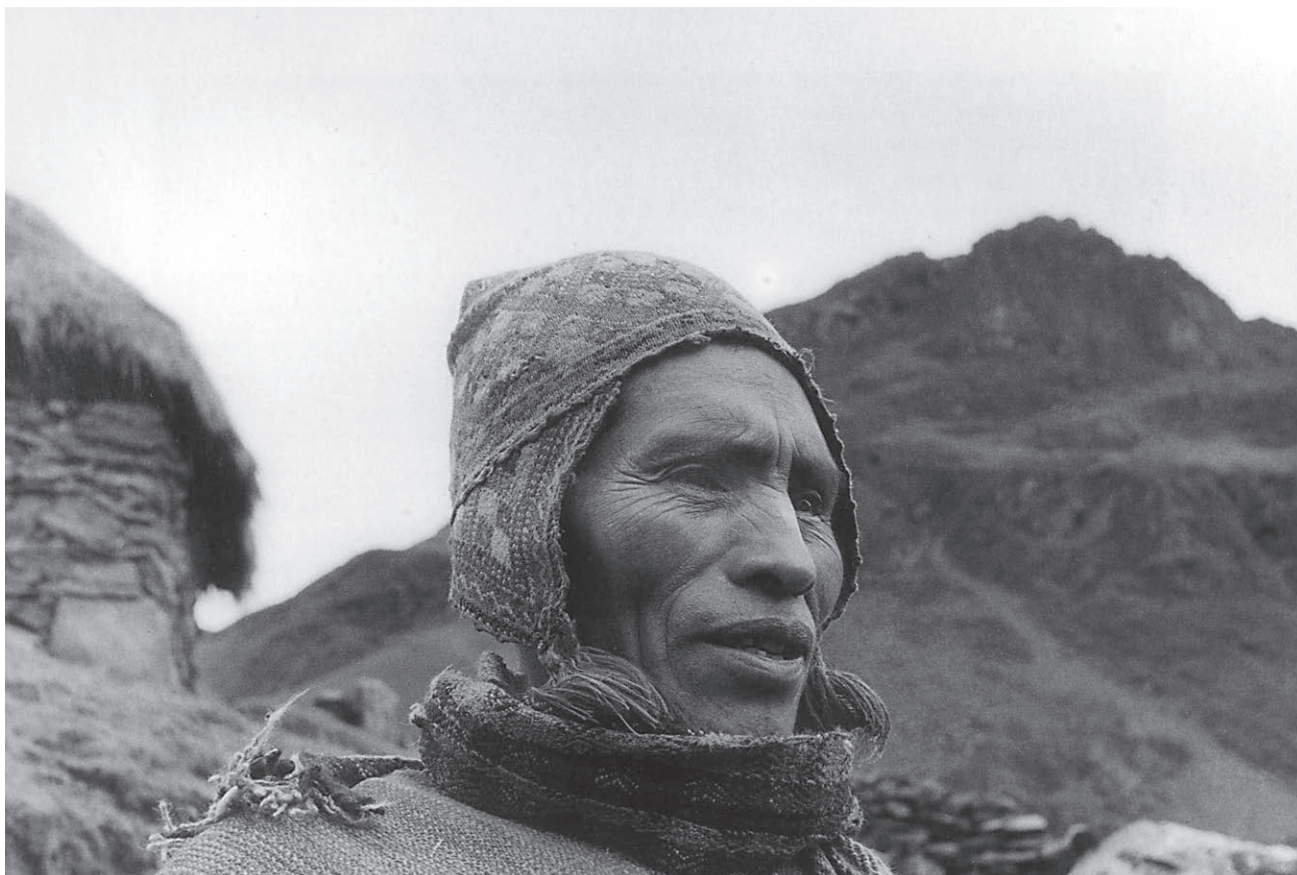

A Q'eros herder in 1989. After almost thirty years, clothing styles have remained constant. Photograph by John Cohen.

His photographs from those earlier times document life in this harsh, barren place. Each photograph tells a story—of tradition, endurance, celebration. Study the hat styles, and you will see continuity in the geometric or condor motifs, the narrow scalloped cast-ons, the patterned earflaps. Compare their more festive, embellished hats with those of the men of Huacatinka, a village in the Ocongate region, also in the shadow of Mount Ausangate. They share the extravagantly conical shapes, the abundance of embellishments, the sense that these hats mark important occasions.

The men of Huacatinka have formed a cooperative in conjunction with the Center for Traditional Textiles of Cusco, which will market their traditional, handspun

The Center for Traditional Textiles is a nonprofit organization in Cusco, Peru, that preserves and celebrates traditional textiles in the region and promotes economic development. In addition to an exhibition gallery and museum shop, weavers and knitters from villages associated with the center demonstrate their work. For more information: The Center for Traditional Textiles, Avenida Sol 603, Cusco, Peru; www.incas.org/center-for-traditional-textiles-of-cusco.

Chullos such as those shown here are available at www.clothroads.com. Proceeds from sales go to the Center for Traditional Textiles of Cusco and to the knitters themselves.



Peruvian chullo with Interlocking Diamonds and Double Square with Flower motifs. Photograph by Joe Coca.

A young man from Huacatinka in Cusco. His habit of wearing a felt fedora over his knitted chullo is typical. Photograph by Linda Ligon.



alpaca chullos, a move that will surely help preserve the craft. We've provided pattern charts for a few of their motifs to use as you please, although these skillful knitters never use charts. They seem to hold an ancestral memory of the geometry and mathematics of a proper chullo and its patterning. Yet they never knit two alike. ❁

ABOUT THE AUTHOR. *Linda Ligon is Interweave's founder and part-time jack of all trades. She is also publisher of Thrums Books (www.thrumsbooks.com) and a frequent traveler in Peru.*

Further Resources

Cohen, John. *Past Present Peru*. Göttingen, Germany: Steidl Publishers, 2010. The book from which these prints were taken, with permission of the author, is part of a collection that includes DVDs, audio CDs, and a volume of photographs documenting weaving among the Q'eros.

Peruvian chullo with Viscacha, Condor, and Square with Flower motifs. Photograph by Joe Coca.



Double Square with Flower

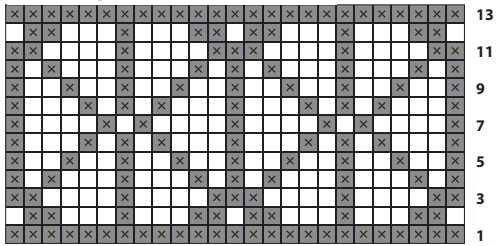

25 sts

Condor

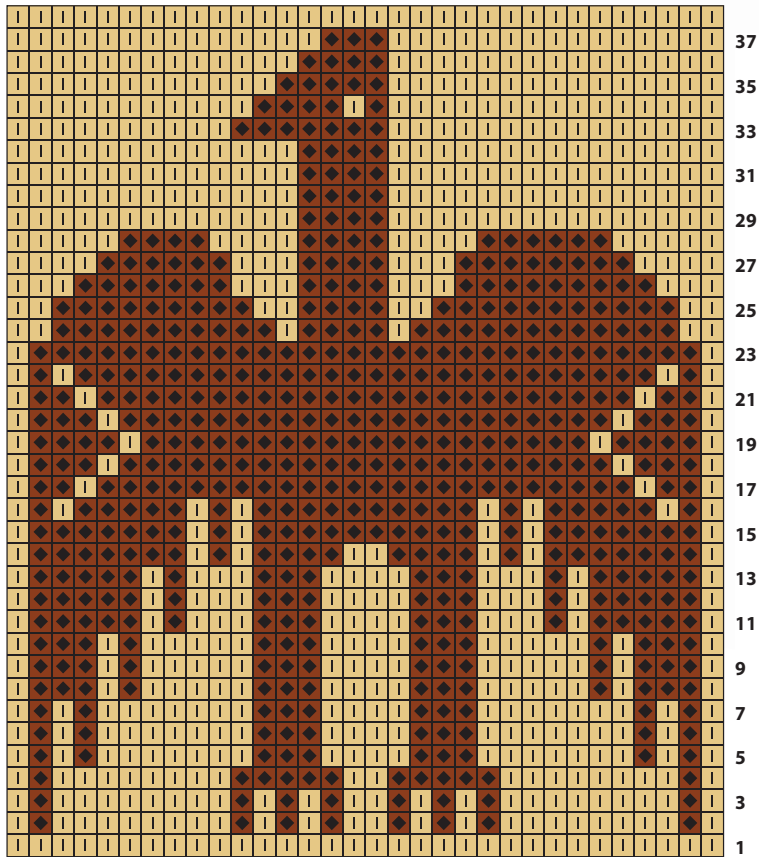

32 sts

- Key
-  Color A
 -  Color B
 -  Color C
 -  Color D
 -  Color E
 -  Color F

These charts may be photocopied for personal use.

✿ Knitting with Dignity: ✿ The Molo Wool Project in Kenya

G W E N M E Y E R

You are about to meet a group of “dignified women” from Kenya. These knitters are part of the Molo Wool Project. Their future is open to positive change, which they will help determine. Already, the colorful animals they create—their own “animal kingdom”—have helped to transform their lives. But the beginning of the project was less a smooth road than an adventure. Each knitter has a story, and these women are finding success by helping and supporting each other as they continue to knit and to develop future products.

Samuel Muhunyu is the director of the nonprofit organization Network for EcoFarming in Africa (NECOFA) based in Molo, Kenya. Molo is a town of about 100,000 people in the Rift Valley, 220 kilometers (136.7 mi) northwest of Nairobi. NECOFA works with farmers, communities, and schools in rural Kenya on a variety of agricultural activities and also helps them address issues involving education, health, food security, and the environment. My husband, John, and I met Samuel Muhunyu at a Slow Food conference in Italy in 2006. At the time, NECOFA was involved in a sheep-improvement project with local farmers, and Samuel invited John, a sheep producer in Oregon, to come to Molo to talk to farmers about lamb production and sales to restaurants. Samuel also was interested in assisting the farmers to develop nonmeat products, particularly using wool, as a source of income. At the time, the sheep producers were paying shearers to take away their wool because they believed that working with fibers was an occupation for “peasants” and unworthy of farmers like themselves.

In January of 2007, we visited Samuel in Molo, where he had organized a daylong meeting with the farmers. Hoping to develop some interest in fiber arts, he had also invited a local spinner to do a demonstration, and he arrived with his homemade spinning wheel of recycled bicycle parts and scrap wood on the back of his bike. After his demonstration, I told the group that fiber arts are popular in the United States and that I was a spinner, too. The surprised farmers asked me to spin on



Jane Langat holds her knitted rabbits, a design which was successful only after she studied her sons' live rabbits for hints as to how to construct them. Photograph by and courtesy of the author.

the wheel. Two of the women in attendance that day were members of the Karunga Women's Group, a women's self-help group that was formed in 2005 and has thirty-five members, ranging in age from twenty-five to



Photographer Tom Barkin with Philomena Nyokabi's knitted version of the baboon who stole his camera lens while visiting Nakuru National Park with members of the Molo Wool Project. Photograph by and courtesy of the author.

sixty-nine. Only a few of the women have completed eighth grade, and about a third of them are single mothers. The women participate in a number of group activities, including gardening and raising chickens; a group-banking fund helps them generate income and enjoy social support from each other in difficult times.

When NECOFA and the Ministry of Agriculture helped the women identify challenges they faced and opportunities they might pursue, individually and as a group, knitting and sewing were identified as the two skills most of them possessed. The women said they had learned to knit from their mothers and grandmothers, who had learned from *mzungu* (people of European descent) settlers, community workers, and missionaries. Most of the women had learned both skills by the age of ten. Until about twenty years ago, mothers typically taught their daughters to knit and sew. For knitting, they used nut grass as yarn and dry grasses such as common thatching grass as knitting needles.

They made balls and human- and animal-shaped dolls by sewing together pieces of old clothes. For stuffing, they used dry grass or dried leaves of tropical hydrangea leaves. They also learned to ravel synthetic yarn from old sweaters and knit the yarns into new products, such as sweaters and tablecloths. Samuel encouraged the women to begin knitting again to increase their income and to consider using wool yarn instead of the synthetic yarn they favored.

Samuel describes the events that followed. "The women began to knit again but felt they were engaging in 'backward skills.' Then, the two Karunga women who attended the farmers' meeting reported to the group what they had seen and experienced." When I demonstrated my expertise at spinning, it had helped to remove the perception of themselves as "poor-illiterate-people," and they became excited. "From then on," he said, "knitting and working with wool gained a different meaning and status in their lives."

NECOFA hired artisans to fabricate spinning wheels for the group and to teach them spinning and natural dyeing. A knitter from a nearby village showed them how to knit yarn to make stuffed animals. In June, Samuel came to Oregon for the Black Sheep Gathering and brought with him two large bags of animals made by the women, which we quickly sold.

Today, a group of about twenty Karunga women participate in the Molo Wool Project. Four members spin yarn for the group, using wool they purchase from local farmers. The women dye with plant materials they collect or with Lanaset dyes to complement the natural colors. Since 2007, they have produced delightful animals, twined rugs, and other products that have earned them more than \$50,000. Last year, a donor provided the resources to build a new workshop on land they purchased with sales of seedlings from their tree nursery.

The women don't use patterns. They learn to knit new products from others or by figuring out a "pattern" on their own. As they begin to create a new item, they study the animal itself or look at a photograph if they have one. When they get "stuck," they ask the group for feedback. Their biggest challenge is trying to determine the number of stitches based on the thickness of handspun yarn, which isn't uniform.

Anastasia Watiri, one of the more accomplished knitters, produces several different animals. She says, "Before I joined the Molo Wool Project, I used synthetic yarn to knit sweaters for my family. One day, while visiting rela-

tives, I strolled in the village and found a white goat tethered by the path. Although I had seen other goats, I had never seen such a lovely one. It was not easy to knit, and I made many mistakes before the product resembled a goat. But I have perfected my skills with help from group members and am able to commit the number of stitches for each part of the body in my mind.”

The History of Wool in Kenya

Although there is some evidence of silk and cotton drop-spindle spinning in Lamu, Kenya, as early as the tenth century A.D., the only fibers in common use in Kenya before 1900 were hibiscus fibers, which were woven into baskets and mats. The farmers and nomadic livestock herders in the interior of the region wore mainly hides and did not develop a weaving or knitting tradition. Eventually, Arabian and Indian mill-woven cotton cloth brought by traders created a strong textile market on the coast of Kenya, and weavers began to use imported Arab looms to weave fabric with cotton.

In the early 1900s, British settlers introduced wool for spinning, weaving, and knitting to Kenya, importing their fine- and medium-wool sheep from Europe. The indigenous fat-tailed “hair” sheep of Kenya, valued more for their hardiness in arid conditions and their strong resistance to internal parasites, were kept primarily for meat and did not produce wool. (Today, the imported European sheep and crosses of these breeds with the indigenous sheep are the major wool and meat producers in Kenya.)

During World War II (1939–1945), the British Colonial Government tried to make Kenya independent of wool imports. The government distributed pamphlets with advice on loom and spinning wheel construction, plant-dyeing methods, and spinning and weaving—all to encourage local production of woollen products. Between the end of World War II and Independence in 1963, a number of workshops produced woollen goods on a small scale. During the 1970s, foreign government agencies, religious groups, nongovernmental organizations, and charities set up small community workshops throughout the country with the aim of skill training and income generation for participants. Run mostly by foreigners, few of these workshops are still in existence. Today, artisans continue to make looms and spinning wheels modeled on the British equipment by hand with recycled or inexpensive local materials.

—G. M.



Women of the Molo Wool Project knitting their animal creations for future sale. Photograph by and courtesy of the author.



Philomena Nyokabi, a member of the Molo Wool Project, with her finger puppets. Photograph by and courtesy of the author.

Jane Langat’s two young sons raise rabbits. She recounts, “My brothers and my husband didn’t rear rabbits, and I always wondered how my sons got interested in the animals. The boys adore the rabbits, and I like watching them care for them. When the women invited me to choose an animal to knit, I decided to start with a rabbit. It was not easy, and I had many false starts. When finally I put something together, it was far from a rabbit. I tried different combinations of stitches in different



Molo Wool Project knitter, Anastasia Watiri, with one of the colored goats she makes. She also enjoys knitting pigs. Photograph by and courtesy of the author.

sections and gradually made progress. In the group, I discussed my problem with other women and studied my sons' rabbits. Now, I can proudly say I have mastered the art and design of the rabbit, which I have committed to memory. After making several rabbits well, I can hardly fail!"

Philomena Nyokabi remembers the day the group went to Nakuru National Park. At their request, we hired a bus and took thirty-nine women and their children to the park to see the animals. Although it was only half an hour away, none of the women had been there, nor had they seen in real life the wild animals they had begun to knit. A friend from Oregon was with us. When he set his telephoto lens in a plastic bag on the ground at his feet, a large baboon grabbed the bag and went over the edge of a cliff with it.

Philomena recalls, "When the huge and menacing monkey attacked one of the visitors and snatched his camera lens, I felt very bad, annoyed, and helpless. This was not the best welcome for a visitor. The man asked if someone would knit the 'annoying monkey' as a souvenir, and I found myself volunteering for the task even without knowing how I was to do it. I embarked on the difficult task with little reference material since the animal was left behind in the park.

"The first product I came up with was a disgrace," she continues. "The women criticized it, and one said

it looked like a cat. Together, they looked at each part of the animal, giving me suggestions on how it could be improved. The mzungu who received the stuffed monkey like the one that attacked him in the park may never know that it was my ninth or tenth attempt!"

The women's greatest challenge now is developing products for the local market. They are learning to weave and have recently completed a weeklong workshop taught by two felters from Holland. A donated industrial knitting machine lets them quickly produce sweaters for sale in the market. They also have planted an acre of mulberry trees, which, when mature, will feed the silkworms they plan to raise. The success of the Molo Wool Project is transforming the lives of the women. They will tell you that the most important outcome of their work is that now they feel like "dignified women." 🌸

ABOUT THE AUTHOR. *Gwen Meyer and her husband, John Neumeister, are directors of Friends of Kenya Schools and Wildlife (www.fksw.org), a nonprofit organization started in 2003 in Oregon. Since 2008, they have worked in partnership with the Network for EcoFarming in Africa (NECOFA; www.necofa.org) on projects supporting community development in five rural Kenyan communities. The Molo Wool Project is one project focused on poverty alleviation through skill building and education in business and leadership. The author thanks Ray Meynink for providing information about the introduction of wool and its early use in Kenya.*

Knitting Traditions

✧ Resource Guide ✧



**Blackberry Ridge
Woolen Mill**

Wonderfully Warm Woolen Spun Yarns
From Our Mill To You

www.blackberry-ridge.com



Kerry Woollen Mills

DUBLIN BAY
Knitting Company

and so much more!
dublinbay.net



MOCO QIVIUT

The World's Most Exceptional Rare Fiber
Responds Well to Fondling!

www.CarylIDesigns.com

caryl@carylIdesigns.com
(208) 756-7156

TAKE 40% OFF All Patterns & Books!

5 Qiviut Yarn weights, Qiviut Fiber Clouds
100% Qiviut & Qiviut/Merino/Silk blends
Mountain Colors Hand-Painted Colors



Put some Vermont
color in your
knitting!

**GREEN
MOUNTAIN
SPINNERY**

WWW.SPINNERY.COM
800.321.9665



There's always
more online

**BOOKS
MAGAZINES
DVDs
MORE**

 shop.knittingdaily.com

✧ Web Listings ✧

Needlework Supplies

Handy Hands, Inc.
www.hhtatting.com
(217) 379-3802

We sell Lizbeth thread, books, satin balls, and hankies.

Shops/Mail Order

Woobee KnitShop
www.woobeeknitshop.com
(307) 760-2092

Products include Brown Sheep, Waverly, Jean Greenhowe, Addi, and Skacel.

Travel

2014 Tours for Knitters & Friends (To Scotland, Ireland & a Cruise)

Memorable travel; Unique itineraries
www.joycejamestours.com
Tel: (613) 695-0889
Email: knitting@joycejamestours.com

Yarns

Jimmy Beans Wool
www.jimmybeanswool.com
(775) 827-YARN (9276)

Fine yarn, fabric, accessories, and more for Needlearts enthusiasts worldwide.

Paradise Fibers

www.paradisefibers.net
(888) 320-7746

Everything for Knitting, Spinning, Handweaving, and Crochet.
Same-day shipping!

Abbreviations

beg—begin(s); beginning

BO—bind off

CC—contrasting color

ch—chain

cir—circular

cn—cable needle

CO—cast on

cont—continue(s); continuing

dc—double crochet

dec(s) ('d)—decrease(s); decreased; decreasing

dpn—double-pointed needle(s)

fol—follow(s); following

hdc—half double crochet

inc(s) ('d)—increase(s); increased; increasing

k—knit

k1b—knit 1 in back of stitch

k1f&b—knit into the front and back of the same stitch—1 stitch increased

k2b—knit 2 in back of next 2 stitches

kwise—knitwise; as if to knit

k2tog—knit 2 stitches together

k3tog—knit 3 stitches together

k5tog—knit 5 stitches together

lp(s)—loop(s)

m(s)—marker(s)

MC—main color

M1—make one (increase)

M1k—increase 1 by knitting into the front and then the back of the same stitch before slipping it off the left-hand needle

M1p—increase 1 by purling into the front and then the back of the same stitch before slipping it off the left-hand needle

Mll—(make 1 left) lift the running thread between the stitch just worked and the next stitch from front to back, and knit into the back of this thread

M1r—(make 1 right) lift the running thread between the stitch just worked and the next stitch from back to front, and knit into the front of this thread

p—purl

p1b—purl 2 in back of stitch

p2tog—purl 2 stitches together

p3tog—purl 3 stitches together

p4tog—purl 4 stitches together

p5tog—purl 5 stitches together

p7tog—purl 7 stitches together

patt—pattern(s)

pm—place marker

prev—previous

psso—pass slipped stitch over

p2sso—pass 2 slipped stitches over

pwise—purlwise; as if to purl

rem—remain(s); remaining

rep(s)—repeat(s); repeating

rev St st—reverse stockinette stitch (p right-side rows; k wrong-side rows)

rnd(s)—round(s)

RS—right side

sc—single crochet

sk—skip

sl—slip

sl st—slip (ped) stitch

sp(s)—space(s)

ssk—slip 1 knitwise, slip 1 knitwise, knit 2

slipped stitches together through back loops (decrease)

sssk—slip 3 stitches one at a time as if to knit, insert the point of the left needle into front of slipped stitches, and knit these 3 stitches together through their back loops (decrease)

ssp—slip 1 knitwise, slip 1 knitwise, purl 2 slipped stitches together through back loops (decrease)

st(s)—stitch(es)

St st—stockinette stitch

tbl—through back loop

tch—turning chain

tog—together

tr—treble crochet

ttr—triple treble crochet

WS—wrong side

wyb—with yarn in back

wyf—with yarn in front

yo—yarn over

yo twice—bring yarn forward, wrap it counterclockwise around the right needle, and bring it forward again to make two wraps around the right needle

*—repeat starting point

()—alternate measurements and/or instructions

[]—work bracketed instructions a specified number of times

Techniques

2 (3, 4, 5) Stitch One-Row Buttonhole

Work to where you want the buttonhole to begin, bring yarn to front, slip one purlwise, bring yarn to back (Figure 1). *Slip one purlwise, pass first slipped stitch over second; repeat from * one (two, three, four) more time(s). Place last stitch back on left needle (Figure 2), turn. Cast-on three (four, five, six) stitches as follows: *Insert right needle between the first and second stitches on left needle, draw up a loop, and place it on the left needle (Figure 3); repeat from * two (three, four, five) more times, turn. Bring yarn to back, slip first stitch of left needle onto right needle and pass last cast-on stitch over it (Figure 4), work to end of row.



Figure 1



Figure 2



Figure 3



Figure 4

Backward-Loop Cast-On

*Loop working yarn and place it on needle backward so that it doesn't unwind. Repeat from *.



Cable Cast-On

If there are no established stitches, begin with a slipknot, knit one stitch in slipknot and slip this new stitch to left needle. Insert right needle between first two stitches on left needle (Figure 1). Wrap yarn as if to knit. Draw yarn through to complete stitch (Figure 2) and slip this new stitch to left needle as shown (Figure 3).



Figure 1



Figure 2



Figure 3

Crochet Chain (Provisional) Cast-On

With waste yarn and crochet hook, make a loose chain of about four stitches more than you need to cast on. With needle, working yarn, and beginning two stitches from end of chain, pick up and knit one stitch through the back loop of each crochet chain (Figure 1) for desired number of stitches. Work the piece as desired, and when you're ready to work in the opposite direction, pull out the crochet chain to expose live stitches (Figure 2).



Figure 1

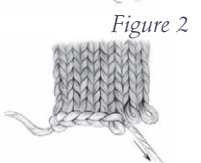

Figure 2

✿ Stop to Shop ✿

CALIFORNIA

Colors 91711—Claremont www.colors91711.com

Colors specializes in natural, fair trade & eco fibers, accessories, and classes for knitters, crocheters & spinners.

248 Harvard Ave. (909) 624-6161

A Yarn Less Raveled—Danville www.ayarnlessraveled.com

Everything you need for your knit/crochet projects—beautiful yarns, patterns, needles, notions, and support to make your project a success. Classes of all levels!

730 Camino Ramon, Suite 186 (925) 263-2661

Uncommon Threads—Los Altos www.uncommonthreadsyarn.com

Beautiful yarns from around the world.

293 State St. (650) 941-1815

Once Around—Mill Valley www.oncearound.com

The felting, stamping, embroidery, fabric-painting, wreath-making, embossing, scrapbooking, decoupage, candle-crafting, bookbinding, glitter, sewing, knitting and, more . . . ARTS and CRAFTS STORE.

352 Miller Ave. (415) 389-1667

Cottage Yarns—South San Francisco www.cottageyarns.com

Your yarn source since 1966! cottageyarns@sbcglobal.net.

607 W. Orange Ave. (650) 873-7371

Purlescence Yarns—Sunnyvale www.purlescenceyarns.com

Purlescence Yarns is the premier resource for knitting, crochet, spinning, and weaving in Silicon Valley. We offer classes for everyone from beginners to advanced crafters.

564 S. Murphy Ave. (408) 735-9276

COLORADO

Gypsy Wools—Boulder www.gypsywools.com

Specializing in natural fibers, hand-dyed, handpainted, and natural color. Exotics, rare and heritage breed fibers, and unusual custom spun yarns. We're not your average yarn store.

1227 Spruce St. (303) 442-1884

Table Rock Llamas Fiber Arts Studio Inc.—Colorado Springs www.tablerockllamas.com

Knitting, crochet, spinning, weaving, felting, and dyeing.

6520 Shoup Rd. (866) 495-7747

FLORIDA

A Good Yarn—Sarasota www.agoodyarnsarasota.com

There's something for everyone at A Good Yarn, Sarasota's ultimate creative spot for all things yarn!

7418 S. Tamiami Trl. (941) 487-7914

IDAHO

Knit-n-Crochet—Coeur d'Alene www.knit-n-crochet.com

Friendly service and inviting atmosphere. Come in and see, or shop online, our large selection of yarn, needles, and accessories.

600 W. Kathleen Ave. #30 (508) 676-YARN

Alpaca Direct—Hayden www.AlpacaDirect.com

Huge selection of luxury yarn, roving, and knitting supplies. Classes and support.

1016 W. Hayden Ave. (208) 209-7079
(888) 306-0111

ILLINOIS

Knot Just Knits—Oak Park www.knotjustknits.com

The new nook for creative knitting, crocheting, and canvas work. No matter what your skill level.

1107-1109 Westgate (708) 948-7943

Wool, Warp & Wheel—Richmond www.woolwarpandwheel.com

Spinning, weaving, and knitting supplies and equipment. Tue–Fri 7 p.m.–9:30 p.m., Sat–Sun 10–5.

5605 Mill St. (815) 678-4063

MARYLAND

Millicent's Yarns & More—Cumberland www.millicentsyarns.com

Premier yarn shop: one of East Coast's top 10! Easy on/off I–68 in western Maryland. Find us on Facebook too.

27 N. Centre St. (855) 722-8200

MASSACHUSETTS

The Woolpack—Acton www.woolpackyarn.com

Yearn for Yarn? Unwind your mind and knit yourself silly in our cozy fiber mercantile.

Acton Woods Plaza (978) 263-3131
340 Great Rd.

Stitch House—Dorchester www.stitchhousedorchester.com

Very cool place to buy yarn, learn to knit, sew, crochet, or have a party.

846 Dorchester Ave. (617) 265-8013

The Fiber Loft—Harvard www.TheFiberLoft.com

Knitting~Weaving~Spinning~Felting. Serving fiber enthusiasts for over 30 years. We have what you need!

9 Massachusetts Ave. (Rt. 111) (978) 456-8669

MICHIGAN

Nautical Yarn—Ludington www.nauticalyarn.com

When you walk into our turn-of-the-century store and see the HUGE selection of yarn, you'll be in heaven.

108 South Rath Ave. (231) 845-9868

MISSISSIPPI

Knutty Knitters—Yazoo City

We carry over 60 lines of lovely yarns as well as books, needles, lessons, workshops, fellowship, and great fun.

128 S. Main St. (662) 746-7555

NEW HAMPSHIRE

Harrisville Designs Knitting and Weaving Center—Harrisville www.harrisville.com

Yarns, Looms and Friendly Loom Products made by Harrisville Designs. Come visit our shop. We have our full product line on display, plus spinning equipment, fibers, yarns, books. Classes.

4 Mill Alley (603) 827-3996

The Fiber Studio—Henniker www.fiberstudio.com

Natural-fiber yarns for knitting and weaving, needles, books, looms, and spinning wheels. Our own handpainted yarns.

161 Foster Hill Rd. (603) 428-7830

NEW JERSEY

Woolbearers—Mount Holly www.woolbearers.com

Full-service knitting, spinning, weaving, and dyeing shop specializing in handpainted fiber and yarns, spinning, and weaving equipment.

90 High St. (609) 914-0003

NEW YORK

Yarn Cupboard—Jamesville www.yarncupboard.com

Conveniently located 10 minutes from the center of Syracuse. Yarns, fiber, spinning wheels, looms, patterns/books, notions, buttons, and accessories.

6487 E. Seneca Tpk. (315) 399-5148

NORTH CAROLINA

The Tail Spinner—Richlands www.tail-spinner.com

Complete fiber arts center: Quality yarns, spinning wheels, looms, classes, related tools, and equipment.

109 N. Wilmington St. (910) 324-6166

PENNSYLVANIA

Gosh Yarn It!—Kingston www.goshyarnitshop.com

A beautiful yarn boutique in Northeastern PA. Visit us for fine yarn, patterns, notions, and knitting & crochet classes.

303 Market St. (570) 287-9999

Natural Stitches—Pittsburgh www.naturalstitches.com

Best selection of natural fibers in Pittsburgh. Knowledgeable staff. Open 7 days. Evenings, too!

6401 Penn Ave. (412) 441-4410

TENNESSEE

Smoky Mountain Spinnery—Gatlinburg www.smokymountainspinnery.com

Come shop in our comfortable surroundings. Everything for spinning, weaving, knitting, crocheting, and needlefelting. Antiques and gifts, too.

466 Brookside Village Wy., Ste. 8 (865) 436-9080

Grafting for Garter Stitch

To graft garter stitch, place live stitches on needles held parallel. Thread tapestry needle with yarn and go through first stitch on front needle as if to purl, then first stitch on back needle as if to purl, leaving both stitches on the needles. *Then go through first stitch on front needle as if to knit and slip it off the needle, go through second stitch as if to purl and leave it on. Go through first stitch on back needle as if to knit and slip it off the needle, go through second stitch as if to purl and leave it on. Rep from * until no stitches remain.



Kitchener Stitch

Step 1: Bring threaded needle through front stitch as if to purl and leave stitch on needle.

Step 2: Bring threaded needle through back stitch as if to knit and leave stitch on needle.

Step 3: Bring threaded needle through first front stitch as if to knit and slip this stitch off needle. Bring threaded needle through next front stitch as if to purl and leave stitch on needle.

Step 4: Bring threaded needle through first back stitch as if to purl (as illustrated), slip this stitch off, bring needle through next back stitch as if to knit, leave this stitch on needle.

Repeat Steps 3 and 4 until no stitches remain on needles.

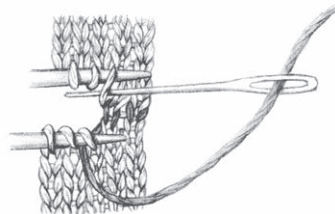

Knitted Cast-On

Place slipknot on left needle if there are no established stitches. *With right needle, knit into first stitch (or slipknot) on left needle (Figure 1) and place new stitch onto left needle (Figure 2). Repeat from *, always knitting into last stitch made.

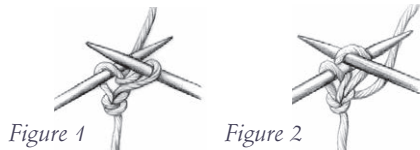

Long-Tail Cast-On

Also called the continental method, this cast-on creates a firm, elastic edge that's appropriate for most projects. This method is worked with one needle and two ends of yarn, and it places stitches on the right needle. The resulting edge is smooth on one side (the side facing you as you work) and knotted or bumpy on the other (the side facing away from you as you work). Most knitters choose to designate the smooth side as the "right" side.

Leaving a long tail, make a slipknot and place on a needle held in your right hand. Place thumb and index finger of your left hand between the yarn ends so that the working yarn is around your index finger and the tail is around your thumb, secure the ends with your other three fingers, and twist your wrist so that your palm faces upwards, making a V of yarn around your thumb and index finger (Figure 1). *Bring needle up through loop on thumb (Figure 2), grab the first strand around index finger with needle, and go back down through loop on thumb (Figure 3).

Drop loop off thumb and, placing thumb back in the V configuration, tighten resulting stitch on needle (Figure 4). Repeat from *.

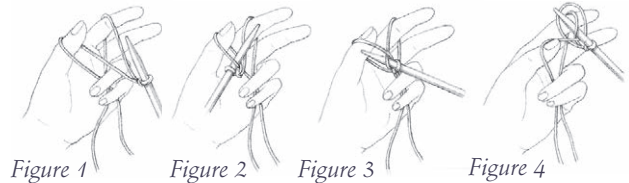

Three-Needle Bind-Off

Also called binding two pieces together, this method seams two pieces together (such as the front and back of a garment at the shoulders) at the same time as the stitches are removed from the needles.

With right sides of the two pieces facing each other and the needles held parallel, insert a third needle knitwise into the first stitch on each needle (Figure 1), wrap the yarn around the needle, and knit the two stitches together (Figure 2). *Knit the next stitch on each needle together, then slip the first stitch on the third needle over the second stitch and off the needle (Figure 3). Repeat from *.

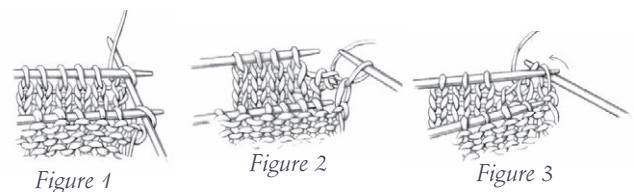

Short-Rows (Purl Side)

Work to the turning point, slip the next stitch purlwise to the right needle, bring the yarn to the back of the work (Figure 1), return the slipped stitch to the left needle, bring the yarn to the front between the needles (Figure 2), and turn the work so that the knit side is facing—one stitch has been wrapped, and the yarn is correctly positioned to knit the next stitch. To hide the wrap on a subsequent purl row, work to the wrapped stitch, use the tip of the right needle to pick up the wrap from the back, place it on the left needle (Figure 3), then purl it together with the wrapped stitch.

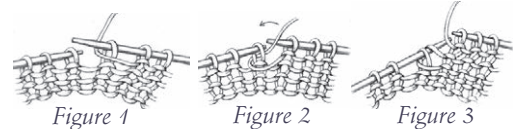

Short-Rows (Knit Side)

Work to turning point, slip next stitch purlwise (Figure 1), bring the yarn to the front, then slip the same stitch back to the left needle (Figure 2), turn the work around and bring the yarn in position for the next stitch—one stitch has been wrapped, and the yarn is correctly positioned to work the next stitch. When you come to a wrapped stitch on a subsequent row, hide the wrap by working it together with the wrapped stitch as follows: Insert right needle tip under the wrap (from the front if wrapped stitch is a knit stitch; from the back if wrapped stitch is a purl stitch (Figure 3), then into the stitch on the needle and work the stitch and its wrap together as a single stitch.

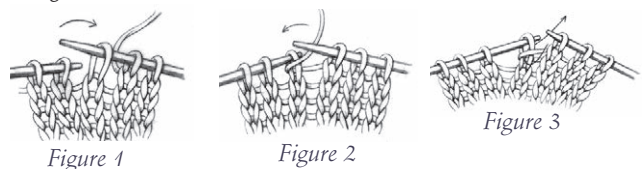

TEXAS

Yarntopia—Katy www.yarntopia.net

Yarntopia carries a multitude of specialty yarns that are sure to please every crafter. Stitching groups and classes available.

2944 S. Mason Rd., Ste. M (281) 392-2386

WASHINGTON

Serial Knitters Yarn Shop—Kirkland www.serialknitters.com

Specializing in local hand dyed yarns, friendly community-based atmosphere and classes.

8427 122nd Ave. NE (425) 242-0086

Paradise Fibers—Spokane www.paradisefibers.net

Terrific selection of wool yarn, knitting needles, wheels, and looms. Order online or stop in. Same-day shipping!

225 W. Indiana Ave. (888) 320-7746

WISCONSIN

The Dragonfly Yarn Shop—Janesville www.dragonflyyarnshop.com

Wool and luxury fibers. Addi and Crystal Palace needles. Lessons by the hour. Home of the Pirouette!

1327 N. Wright Rd., Ste. 5A (608) 757-9228

Classifieds

Travel

2014 TOURS FOR KNITTERS & FRIENDS. Three unique itineraries: May - Cruise from Norway to Iceland (with interesting ports en route); July – the 16th Scottish Skeins & Skerries Tour; “Treasures of Ireland”—Come with us in Sept./Oct. and visit Dublin, Adare, Cork, Dingle Peninsula, Donegal and more... including a workshop with an Irish designer. Watch our website for details: www.joycejamestours.com or call (613) 695-0889. email: knitting@joycejames.com

CRAFT CRUISES—Join us on a knitting Cruise! Travel with likeminded people while learning new skills and shopping for souvenir yarn. Visit www.craftcruises.com or call (877) 97-CRAFT.

Ad Index

| | |
|--|-----|
| Blackberry Ridge Woolen Mill | 123 |
| Brown Sheep Company | 3 |
| Caryll Designs | 123 |
| Dublin Bay Knitting Co. | 123 |
| Green Mountain Spinnery | 123 |
| Interweave. .5, 6, 7, 55, 89, 111, 127, bc, ifc, ibc | |
| Kelbourne Woolens (The Fibre Co) | 7 |
| Oomingmak, Musk Ox Producers | 5 |
| Simply Shetland LLC | 7 |
| Treenway Silks/Susan Du Bois | 5 |
| Universal Yarn | 3 |

What's Missing?

Your ad should be here!

For more info contact
Stephanie Griess
at (877) 613-4630
or sgriess@interweave.com.

COME AND
Crochet Awhile!

Join our **FREE** community for crochet lovers just like you.

Get started with a **FREE** download of one of our popular pattern collections and sign up for free.

www.CrochetMe.com/Free-eBooks



✿ Sources for Supplies ✿

Brooklyn Tweed Shelter

www.brooklynntweed.net
(Coast Salish Fingerless Gloves)

Brown Sheep Nature Spun

www.brownsheep.com
(Binge Bjärbo Cap)

Cascade 220 Fingering

www.cascadeyarns.com
(Welsh Socks with a Quirk)

Cascade Heritage Silk

www.cascadeyarns.com
(Barnim-Style Stockings)

The Fibre Company Canopy

www.kelbournwoolens.com
(Vävnaden Handwarmers)

Fyberspates Scrumptious Lace

www.fyberspates.co.uk
(Herring-bone Stripe)

HiyaHiya Needles

www.hiyahiyanorthamerica.com
(Rose Leaf Lace)

Imperial Yarn Columbia

www.imperialyarn.com
(Salish Fusion Toque)

Jamieson & Smith Supreme Lace Weight

www.shetlandwoolbrokers.co.uk
(Uyeasound Table Runner)

Jamieson's Shetland Spindrift

www.simplyshetland.net
(Slyde Cardigan)

Kerry Woolen Mills Aran Knitting Wool

www.dublinbay.net
(Tree of Life Aran Vest)

Lion Brand Wool-Ease

www.lionbrand.com
(Macedonian Cap)

Louet Euroflax Linen

www.louet.com
(Knitted Doily, Doily No. 1, and Rose Leaf Lace)

Norsk Engros 50/2-H Linen Thread

www.needlestack.com
(Doily No. 3)

Presencia Fincrochet

www.presenciaamerica.com
(Coral Pattern)

Schachenmayr Regia 3-Ply

www.westminsterfibers.com
(Prince of Wales Sanquhar Gloves)

Shelridge Farm Soft Touch Lace

www.shelridge.com
(Kajakakiri Stole)

Universal Yarn Whisper Lace

www.universalyarn.com
(Porcupine Stitch)

Upton Yarns Cotswold x Romney Fingering Weight

www.uptonyarns.com
(Winter: A Sanquhar Glove Pattern)

Windy Valley Musk Ox Pure Qiviut

www.windyvalleymuskox.net
(Arctic Tundra Scarf)

Take a look at knitting through the eyes of *Downton Abbey*

Enjoy **27 knitting patterns** inspired by the lavish sets and styling of the hugely popular television series *Downton Abbey*, from the editors of *PieceWork* magazine.

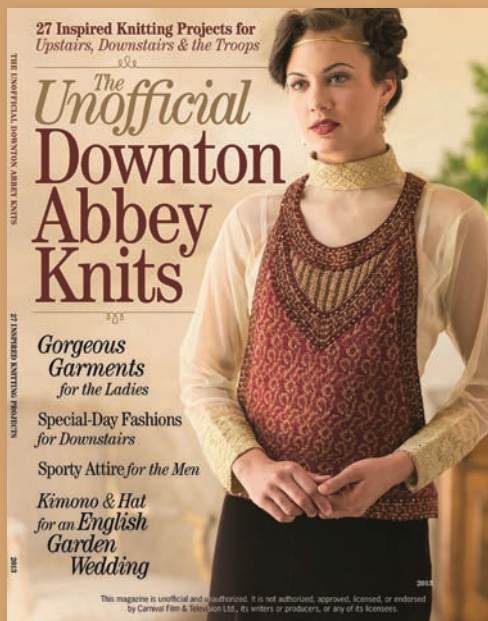

Transport yourself to Downton Abbey! This 144-page special issue dives into the true history that surrounds the fictional setting of the hit television show, and includes projects inspired by the lavish sets and styling including knitted lace cardigans, socks, and more.

Available at your local yarn shop
or at InterweaveStore.com

Due to copyright restrictions this magazine is only available for purchase in the United States. This magazine is unofficial and unauthorized. It is not authorized, approved, licensed, or endorsed by Carnival Film & Television Ltd., its writers or producers, or any of its licensees.



NOW AVAILABLE!

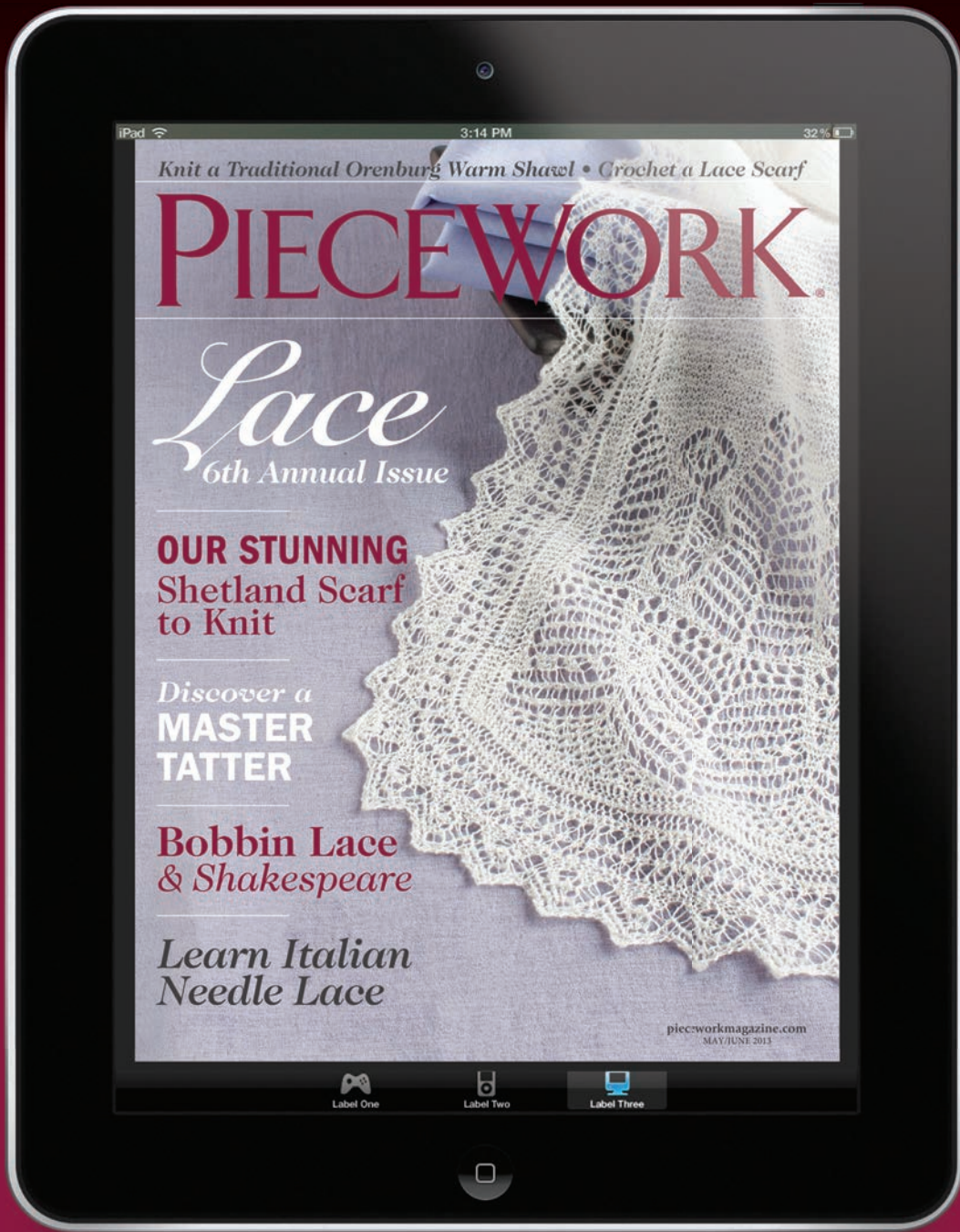

Available on the
App Store

amazonkindle

