

May/June 1987

\$4.00

WEAVING
OF THE
NORDIC COUNTRIES

Handwoven



BACK TO THE BASICS

The new "Hands On" series from Interweave Press begins with the basics, offering affordable entry-level coverage of the timeless crafts of weaving and spinning.

Each of our "Hands On" books is carefully designed with lucid text and abundant photographs and illustrations to get the beginner off to a good start with materials at hand, and to lay a solid foundation for building advanced skills.

If you are an advanced weaver and/or spinner, our "Hands On" series will refresh your memory with technical how-to's and hints, and spur creativity with unique project ideas.

HANDS ON WEAVING

by Barbara Liebler

A logical, step-by-step introduction to weaving that makes everything clear and easy. Beginning with instructions for building a simple frame loom, **Hands On Weaving** proceeds through discussions of rigid heddle and harness looms. Along the way are complete project instructions for creating beautiful handwoven garments and functional household accessories including pillows, rugs, sweaters, scarves, jackets and more.

***A Better Homes & Gardens Craft Book Club selection**

8½" x 11" / 112 pages/color photography/illustrations/paperbound/\$6.95.

Available now.



HANDS ON RIGID HEDDLE WEAVING

by Betty Davenport

The basic guide to weaving on the rigid heddle loom, a portable and affordable alternative for beginners and weavers-on-the-go. You'll learn how to choose and warp a rigid heddle loom, and how to create wonderful things—clothing, table linens, tapestries, pillows, bags, and blankets—using variations of plain weave, pick-up, and lacy techniques.

8½" x 11" / 112 pages/color photography/illustrations/paperbound/\$6.95.

Available in May.

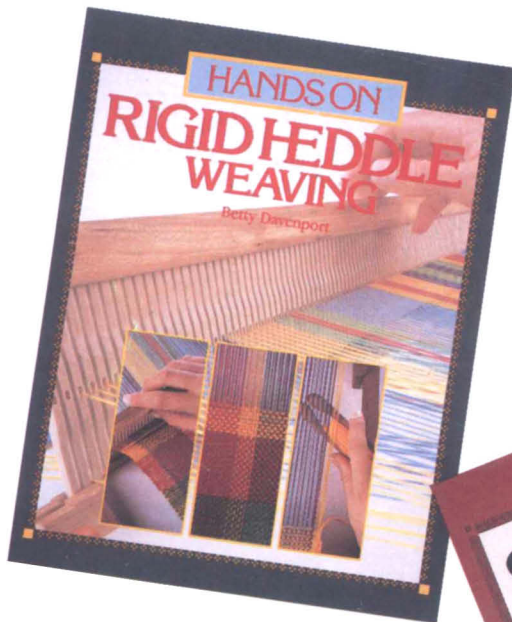

HANDS ON SPINNING

by Lee Raven

From the editor of **Spin Off**, this comprehensive reference teaches everything there is to know about spinning: understanding the spinning process, preparing wool, cotton, linen, and other fibers, making a simple spindle, choosing a treadle wheel, drafting, plying, and finishing. Included are instructions for producing useful and attractive items from your handspun yarn.

8½" x 11" / 112 pages/color photography/illustrations/paperbound/\$6.95.

Available in June.



INTERWEAVE PRESS

306 North Washington Avenue
Loveland, Colorado 80537

Available at your local weaving/spinning shop or from Interweave Press. To order, please refer to the Book Order Insert inside this issue of Handwoven.

Handwoven

from  Interweave Press

FEATURES



On the cover: The colors for this Inspired Bedspread by Anne-Mette Holm of Denmark were taken from an antique milk garland. For more on this project see page 49 and the Instruction Supplement located between pages 90 and 91.

- 23 Idea Notebook
No More Hot Hands: A Handwoven Skillet Holder!
- 32 Scandinavia Revisited
Reflections On the Weaver's Art by Charles S. Talley
- SWEDEN
- 34 From Hand To Hand: Swedish Weaving Today by Hans Krondahl
With sections on contemporary Swedish weaving, weave structures, historical notes and projects by Inga Krook, Margaretha Essen-Hedin, Kerstin Åsling-Sundberg and Astrid Sonesson.
- DENMARK
- 44 Danish Textiles: At Home In a Changing World by Charles S. Talley
With sections on contemporary Danish weaving, weave and design, and projects by Elisabeth LaCour, Anne-Mette Holm, Jette Kai and Kim Naver.
- NORWAY
- 52 Weaving In Rural Norway: A Living Tradition by Lila Nelson
With sections on contemporary Norwegian weaving, weaving history, and projects by Åse Blake, Phyllis Waggoner, Mary Temple and Myrna Golay.
- ICELAND
- 62 Icelandic Weaving: Saga In Wool by Hildur Hákonardóttir
With sections on contemporary Icelandic weaving, traditional weave structures, and projects by Louise Heite and Áslaug Sverrisdóttir.
- FINLAND
- 68 Finnish Textile Art: From Byzantine To Bauhaus by Kirsti Rantanen
With sections on contemporary Finnish weaving, traditional weaves, and projects by Merja Winqvist and Riita Mäkinen.
- 77 A Textile Resource Guide To the Nordic Countries
compiled by Charles Talley
- 91 Keep It Simple: Tussah Silk Top by Debbie Buchele
- 98 Reflections On 7560 Weft Picks by Linda Ligon

COLUMNS

- 18 Your Weaving Teacher: Weaving – Better Than Bridge
by Deborah Chandler
- 27 Finishing Finesse: Tacky-To-Tasteful – Finishing Touches For
Household Linens by Louise Bradley
- 89 Interface: Computer Networking by Carol and Stewart Strickler

DEPARTMENTS

- | | | | |
|----|---------------------|----|---------------|
| 2 | Editor's Page | 14 | Books, Etc. |
| 7 | Letters | 25 | News & Events |
| 11 | Dear Tabby | 81 | Calendar |
| 12 | Tricks of the Trade | 97 | Product News |

Editor's Page

I learned to weave in Iceland. But more than that I learned the meaning of craftsmanship. I was an exchange student for a year, and spent several weeks at a special "home ec" school to learn some of the Icelandic traditional textile crafts. In a matter of a few weeks I'd knitted for the first time, done several pieces of counted cross stitch and woven off all the warps left on the looms in the weaving studio.

The most valuable lesson I learned, though, was a way of working and approaching handcrafts. And it was hard. I remember finishing the hem on a piece of embroidery; I was pretty proud of it until my teacher told me to rip it all out because it wasn't perfect. I'd gone up one thread somewhere along the way. Well, I could 'kind of' tell the hem was a little off, but the piece was finished. . . . My teacher persisted though, and out came the hem. In the end, well, it really *was* better, and sure, that one thread had made a difference.

As I've looked at and admired the pieces featured in this issue, I've begun to realize that this way of working and thinking is not only representative of Iceland, but of the other Nordic countries as well. Our Scandinavian counterparts have an eye for detail, an insistence on perfection, and an unhurried approach to their work. For them, the process is as important as the end product.

These values are reflected in the design process, too. Take a careful look at the projects in this issue: there's subtle color blending, little surprises, and lots of depth to pieces that on first glance appear very simple. And these, I think, are what makes Scandinavian weaving so special: meticulous execution, and thoughtful design that doesn't shout for attention, but slowly reveals itself as we study it.

This issue would not have been possible without the very knowledgeable help of guest editor Charles Talley. Charles has been involved in the textile arts field for the past 15 years. He is the author of *Contemporary Textile Art: Scandinavia*, and has travelled extensively throughout the Nordic countries since 1980, including a three-year residence in Sweden. Since returning to the United States, Charles has worked as a guest lecturer at California College of Arts and Crafts in Oakland. At present he is involved in special studies at the Graduate Theological Union in Berkeley, California.

A special thanks, too, to the authors and designers who willingly shared their thoughts and weaving with us. The schedule was not always an easy one to meet, and the efforts required to translate and package their work required heroic efforts in many cases.

And you, dear reader, I hope you'll view this issue as a personal visit to these countries, getting to know and appreciate our Nordic counterparts through their weaving and words. Have a great summer. See you in September.

Jane Patrick, editor

National Spinning and Weaving Week

We've been getting quite a few requests already about the dates for National Spinning and Weaving Week. It is always the first full week of October (this year the dates are October 5-11). You might want to start planning now to make this a festive week in celebration of our crafts. This is a great opportunity to share our excitement about what we do with others: plan a weaving demonstration at your local elementary school or rest home, give a program to your service club, or just throw a party for all your weaving and nonweaving friends.

Spin-Off Rendezvous

If you're a spinner, you'll want to be a part of our gala celebration of *Spin-Off*, our sister magazine, which will be ten years old this fall. This conference will be in September at the YMCA of the Ozarks in Potosi, Missouri. Send us a long SASE with two stamps for details about attending.

Addendum

We've referred several times to Charles Talley's book, *Contemporary Textile Art: Scandinavia*. It is not available in this country but can be obtained by writing directly to the publisher: Bokförlaget Carmina, Norbyvägen 33, 752 31 Uppsala, Sweden. \$35 postpaid (U.S. funds; personal check/money orders are okay). Allow 6-8 weeks for delivery.

Publisher Linda C. Ligon
Editor Jane Patrick
Technical Editor Carol Strickler
Special Assistance Deborah Robson, Jean Scorgie
Assistant Editor Dale Pettigrew
Editorial Advisors Kathryn Wertenberger,
Mary Kay Stoehr, Ronnine Bohannan
Contributing Editors Sharon Alderman, Anne Bliss,
Betty Davenport, Constance LaLena, Barbara Liebler,
Deborah Chandler, Carol Strickler, Louise Bradley
Production Marc M. Owens
Administrative Assistant Karen Evanson
Photography Joe Coca
Photo Styling Jane Patrick, Cathleen Solsky
Illustrations Ann Sabin
Advertising Sharon Altergott

Public Relations Karen Hirmer
Circulation Donna Melton
Distribution Lois Biederstadt, Julie Emerson
Chris Hausman
Shipping Rod Baum, Mike Loewen
Bookkeeping Mary Nell Schwindt
Mail Services Clerk Diana Vander Leest-Rubense
Support Services Sally Ornelas

HANDWOVEN is published five times a year (January/February, March/April, May/June, September/October and November/December) by Interweave Press, Inc., 306 North Washington Avenue, Loveland, Colorado 80537. (303/669-7672). ISSN 0198-8212 (USPS #129-210).

Your customer number, found on your address label, is your key to the best service possible. *Please include it*

with all correspondence to avoid delays or errors.

All contents of this issue of HANDWOVEN are copyrighted © by Interweave Press, Inc., 1987. All rights reserved.

Designs in this issue of HANDWOVEN are for inspiration and personal use only. Exact reproduction for commercial purposes is contrary to the spirit of good craftsmanship.

Subscription rate is \$18/year in the U.S., \$22.00 in Canada and other foreign countries. Second class postage paid at Loveland, Colorado and additional offices. U.S.A. Newsstand Distribution by Eastern News Distributors, Inc., 1130 Cleveland Road, Sandusky, Ohio 44870. POSTMASTER: Send address change form 3579 to Handwoven, 306 North Washington Avenue, Loveland, CO 80537. Subscribers please allow 6 weeks for processing address changes. 37.5M4987:HP/AC

Create a masterpiece. Naturally.

JaggerSpun coned yarns bring out your artistic best. With over 140 colors to choose from in a variety of textures, weights and blends, the creative possibilities are endless.

JaggerSpun uses only 100% worsted spun wool and wool-silk to produce five unique product groups — Maine Line, Zephyr Wool-Silk, Superfine Merino, Heather and JaggeRagg. Each a work of art. Naturally.

Explore our palette of colors and let your imagination loose. Send \$4.00 for our complete sample collection to:

JaggerSpun, Dept. HW
Water Street,
Springvale, ME 04083
(207) 324-4455



JaggerSpun



In the Swedish tradition . . .
Glimåkra Looms



Borgs Yarns
... since 1734

From rugs to fine fabrics . . . from beginners to advanced professional weavers . . . Swedish tradition means Glimåkra Looms and Borgs Yarns.

Send \$2.50 for our full-color catalog introducing our extensive line of looms and weaving accessories. Ask your yarn store to show you the Borgs sample cards — over 1000 separate color samples of wools, cottons, linens, and cottolins (50/50) . . . or send \$10.00 for your complete set.



GLIMÅKRA LOOMS
'n **YARNS, INC.**

1304 Scott Street, Petaluma, CA 94952 (707) 762-3362

This picture also available as a poster. Please send \$3.95 for postage and handling.

Linked-loop tie up cord
and "quiet" heddles – a
winning combination
for most looms:

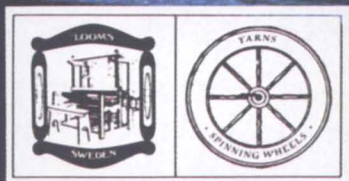

Glimåkra Looms 'n Yarns, Inc.

1304 Scott Street
Petaluma, CA. 94952 – USA
Phone (800) 843 – 9276, or
(707) 762 – 3362

Send \$ 3.00 for the Texsolv sample
bag with an instruction booklet.

What you have in mind ...



... we put in your hand.

Like Halcyon Rug Wools, designed just for you with the richness of earth, sky and sea.

Halcyon Rug Wools are among over 75 styles of yarn which, along with fibers, books, and equipment, are available directly to you through the Yarn Store in a Box[®] sample set. For more information, please call TOLL FREE 1-800-341-0282 or write

Halcyon Yarn • 12 School Street • Bath, Maine 04530

Letters

First Lessons

I've found that first lessons can occur at any stage of learning. I don't remember how many warps I've put on, there have been so many, but this morning I was having big trouble with an 8/2 cotton warp, usually an easy one for me. I got one side nice and even and worked my way across, adjusted the tension, only to find that the first threads were too loose. Then I would start again—tighten, loosen, tighten, loosen, but it was *still* uneven. AAARGH!

In an attempt to discover what was amiss, I peered through the reed, looked at the heddles and the treadles; all seemed to be in order. Out of frustration, I got up, and for a change of pace, washed the dishes and chased the chickens off the porch. As I walked back toward the loom, I noticed that one of the braces on the back beam had come loose. The back beam was crooked; this warp could never be even.

I had wasted at least one hour, simply because I had not looked over my entire loom when I first noticed I had an unusual problem. The seemingly obvious lesson I learned: Things change, both in life and in the status of my loom.

In the future, if something seems to be radically wrong, I will be quick to do a thorough, not cursory, "preflight". —Gail McWilliams, Sonoma, California

Connecting

While visiting my mother this evening, I picked up the March/April issue of your magazine. The article entitled "Swatch Collection #15" immediately caught my attention. The author, Sharon Alderman, spoke of a Peruvian mantle as having been the highlight of her visit to the Dallas Museum of Art and of the inspiration she drew from it. In a moment of introspection, she looked at her own hands and wondered about the hands of the people who wove the mantle, when and how they lived, and how they felt about their craft.

Perhaps this idea of seeing something old and connecting with it very strongly, reinterpreting it and making a contemporary statement, in whatever medium we are working in, is common to all crafts. I am a woodworker, incidentally, and I have shared Sharon Alderman's experience many times. Congratulations on a superb

article. —Tom E. Wisshack, Galesburg, Illinois

On Storage

I line floor-to-ceiling shelves with bright green pickle buckets from Burger King. These make perfect storage compartments for my yarns. Laying the buckets on their sides creates a very pretty sight as well as readily visible yarns.

I advise you to wash your pails first, unless you like the smell of pickles. . . .
—Ruth Blakely, Hilton Head Island, South Carolina

Many thanks for printing my letter (Yarn records, Jan/Feb 1987). Seeing the problem in print helped me focus on it and find a solution that worked for me.

A few days after reading the issue, I was shopping with a friend in a closet storage shop when the solution was there before my eyes. I quickly purchased two clear plastic sweater storage bags—the kind that hang on a closet rod that have eight shelves and a zipper down the front. The bags store an amazing amount of yarn that is

Our Carolina Cottons Are Going Home



Effective: May 27, 1987, Weaver's Way will relocate in Columbus, North Carolina
Our order phone, 1-800-348-3483, will remain the same
Our new address will be:



Weaver's Way
P.O. Box 70
Columbus, N.C. 28722

visible through the plastic as well as easily accessible. I keep an inventory of each compartment on a 3×5 card clipped to the edge. Ounces on hand are noted on the card.

There is another benefit as well. To get the bags in the closet, I finally had to dispose of those items long overdue to become rag rugs. A painful separation to be sure, but once done, it gave me a real sense of satisfaction to have well-stored yarns, new-found space, and up-to-date organization. —Elizabeth Cunningham, Bellingham, Washington

We're still getting lots of storage solutions which we'll share in a special section in the September/October issue. —ed.

Fighting Back

I now realize what it is like to belong to a minority group. After reading Constance LaLena's article "Changes in Weaving", I know that the male weaver has to "fight" to be acknowledged in this "female profession". Alas! —Fr. Aquinas Stack, Carmelite Priory, Tarrytown, New York

It's sad, but true, only 3% of our subscribers are male (and it is our belief that this number is pretty proportional to the num-

ber of males in the general weaving public). What's equally true is that I would love to see this number increase. Any ideas on how to increase your ranks would be delightfully considered! —ed.

Reader Resource

Many thanks to Linda D. Tague of San Jose, California, and the anonymous reader in Portland, Oregon, for their help in providing information on the Kyra Loom. Here's what we've found out: The Kyra Loom, once produced in Buffalo, New York, is now being manufactured by Vernon Rider in Springville, New York. You won't find Kyra Looms in the Springville phone book, but rather, information about the looms should be addressed to Daryl Patterson, Daft Dames Handcrafts, 13384 Main Rd., Rt. 5, Akron, NY 14401.

Our Readers Ask:

In the '70s there were several small tapestry loom manufacturers on the West coast. A California manufacturer made the Brittany loom; another, in Seattle, made several models, one known as the Cigne Noir (Black Swan). I believe both the manufacturers are out of business, but if any of

your readers know the whereabouts of these manufacturers, or have one of their looms, I would like to hear from them. —Peter Mitchell, 16 Kinsington Ave., West Newton, Massachusetts 02165.

Readers, if you can be of any assistance, please drop Peter a note. —ed.

I recently acquired a four-shaft counter-balance loom made by the Forsythe Loom Company (School of Textiles and Hand Crafts, patented June, 1919). After assembling the loom, I am left with a few extra pieces and a broken piece that I need to replace. I wonder if any of your readers know where I might get parts and an instruction manual for this loom. Does the company still exist? Is there someone out there with a Forsythe Loom who could be of assistance? —Camille Gontarek, San Jose, California

We'd be interested in any information you might have about this loom. Your editors are curious about this loom, too. —ed.

Your editors are eager to hear what's on your mind: about the magazine, about the state of weaving as a craft, about how weaving fits into your life. Write us: "Letters", Interweave Press, 306 N. Washington Ave., Loveland, CO 80537.



Fiber Fascination

Not just silk... but a wide selection of yarn and ribbon for the weaving and knitting arts... velvet chenilles, metallic glitter, shimmery viscose, crisp linen and cottons, novelty wool blends...

The Anthea Collection of natural fiber yarns from Switzerland are now distributed through Silk City Fibers.

Introductory material upon request. To the trade only.

SILK CITY FIBERS

SILK CITY FIBERS 155 OXFORD STREET, DEPT. HW PATERSON, NEW JERSEY 07522 201-942-1100
YARN SHOWROOM: 488 7th AVENUE, NEW YORK, NEW YORK • BY APPOINTMENT ONLY

THE SOUVEREIGN



The loom for the professional rug and tapestry weaver.

If you need a very heavy duty and wide loom—The Sovereign is it. The Sovereign is designed and built to provide years of service for the needs of the most demanding weaver.

The Sovereign is available in four weaving widths, from 6½ ft to 11½ ft.

To withstand the tension and heavy beating, all beams are made of steel.

The ratchet wheels have a gear drive and are located on the outside of the loom. This allows high warp tension as well as being able to weave the full width of the loom.

The full width bench is supplied with either one or two sliding seats.

The shed can be kept open by the use of a treadle lock.

The hanging beater can be locked in the back position.



Glimåkra Looms'n Yarns, Inc.

1304 Scott Street
PETALUMA, CA 94952
(707) 762 - 3362

Finely Crafted Looms for the Caring Weaver



NOT SOLD THROUGH DEALERS
NO EXPORTS

Mr. Gilmore, the originator of push up type harnesses and floating type lams, has been weaving and building looms for over 54 years. Constantly improved since 1936, his looms are the ultimate in craftsmanship. Made mostly of hard eastern maple, these looms are available in 26", 32", 40", 46" and 54", 4 and 8 harnesses.

(Illustrated is the 46" 8 harness loom)

Free Brochure

GILMORE LOOMS SINCE 1936

1032 N. Broadway, Stockton, CA 95205

"Dear Tabby"

I have a counterbalance loom and would like to know how to tie up the treadles when the tie-up looks like this: In other words, how do I tie up only one treadle to one shaft when my loom does not operate this way?

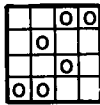

There are a couple of things you can do, and they will depend on what your loom will or will not do. On some looms your best solution is to not change the tie-up (leave it tied up as usual: 1-2, 2-3, 3-4, 4-1, 1-3, 2-4) but to try to create your one-shaft shed by pressing on two treadles at the same time that both contain the one shaft you want to lift. For example, if you want to lift shaft one, step on two treadles at the same time that contain shaft one in the tie-up, such as 1-3 and 1-2. Fidget around with how much pressure you need to step on the treadles with to get a second, narrow, one-shaft shed to emerge.

An alternative is to change your tie-up and tie one shaft to one treadle and three to the other. You'll probably have to add another tie-up cord for the third shaft, and this works more satisfactorily on some looms than others. Usually though, regardless of the loom, this shed will be narrower and not as clear as when lifting shafts in pairs. Again, so much of what will work best depends on what kind of loom you have. You'll need to do some playing around until you come up with the right combination.

Is there a method of advancing the warp on a Swedish style loom that precludes having the warp leap off the back beam in 15-18" lengths? This causes the weaver to throw a cat fit, resulting in elevated blood pressure. It prevents the establishment of a comfortable weaving cadence and an even beat.

What's happening when you're releasing your warp is that the back beam is jumping with the sudden release of tension. You can take care of this on any type of loom by releasing the tension on the cloth beam first. Very gradually lift up the pawl on the front ratchet and ease the tension off. Then release your back beam.

I like to weave with fine yarns such as 16/2 or 20/2 cotton. Everything is fine until I remove the lease sticks in front to start beaming. When I slide the sticks out I find the warp is in tangles and remains tangled all through the beaming process. (I put the lease sticks in the warp while it is still on the warping board.)

I'll bet you are measuring more than one end at a time — and it is this that's causing your problems. It is okay to measure more ends at once, but what you don't want to do is have them twist around each other. When you measure two or more ends at once, keep them separated at all times with the fingers. Or try using a warping paddle to keep your ends separated. You also might experiment with leaving your lease sticks tied to the castle or front beam (depending on your warping method) during beaming. I have a friend that beams her warps this way as a matter of course and finds it quite satisfactory.

Having a weaving problem you can't solve? Write me, "Aunt Tabby", Interweave Press, 306 N. Washington Ave., Loveland, CO 80537.



OF COVERLETS

the legacies, the weavers

by sadye tune wilson
doris finch kennedy

AWARDS WINNER THE TENNESSEE ASSOCIATION OF MUSEUMS
THE AMERICAN ASSOCIATION FOR STATE AND LOCAL HISTORY

- o 496 pages — size 10 1/2" x 14"
- o 200 color — plates of coverlets, 5" x 5"
- o 350 black and whites of coverlets
- o 200 duotones of weavers and homesites with a treasury of family anecdotes
- o 400 traditional coverlet pattern drafts, 4-harness
- o Unique GRAPHIC MOTIF CLASSIFICATION SYSTEM for analyzing coverlet patterns
- o ILLUSTRATED ALPHABETICAL CROSS-REFERENCE of patterns and names to other published sources

Price \$70.00 plus postage/handling \$4.00 each (p/h overseas \$11.00) TN residents add sales tax \$5.43 each

MANUSCRIPT

♦ NOTES ♦ 320 pages, 6 1/2" x 9 1/4", hardcover
♦ Price \$25 plus \$1.50 P/H
♦ WEAVING ♦ TN residents add tax \$1.94
Color slides of swatches available

By JAMES M. HOLMES

This Tunstede republication edition contains two books — *Manuscript Notes on Weaving for First Year* and *Manuscript Notes on Weaving for Second and Third Year*. The works were originally published by the author, James Holmes, M.S.A., in Burnley, England in 1912 and 1914. These text-workbooks were used in technical textile schools that trained students for work in the textile mills of England at the turn of the century. Today, intermediate and advanced weavers, especially those who use multi-harness, dobby, and mechanical looms, will find information and ideas presented which are seldom found in modern weaving texts. The beginning weaver will be inspired to master weave-structure analysis and complex drafting. The sections on dobby and Jacquard looms are unsurpassed in the depth of knowledge presented on loom mechanisms and cloth structures woven on these looms. The engravings of looms and equipment and line drawings of loom mechanisms are extensive. Fabric swatches, reproduced in black and white, illustrate many of the weaving patterns.

Prepay, allow 3-6 weeks delivery. Library and quantity discounts.

ORDER FROM:

Tunstede

Sadye Tune Wilson
212 Vaughn's Gap Road—Dept. HW
Nashville, TN 37205 (615) 352-0971

Tricks of the Trade

Weighting loose ends

For an easy way to put tension on broken, repaired or loose warp ends, I use empty 35mm film canisters and ball bearings for weight. The fiber can be coiled up and stored inside the canister or wound around the outside to keep it neat.

Jacque Taylor
Riverton, Wyoming

Help with tying on

Tying onto the front apron rod is easy, with the rod held in place. I knot two 4½" loops of nylon cord. With the beater secured upright, I pull these loops through the reed, insert the rod, and tighten between the beater and the front beam. With beater and rod in this position, I also can experiment with setts. I can quickly thread the warp through the reed and over the rod and finger weave the weft.

M. Kaulitz
Louisville, Kentucky

Tame those fuzzies

At last! The perfect answer to no-problem-weaving with sticky yarns, such as mohair. While the yarn is on the warping board, just spray it thoroughly

with Static Guard. (Yarn dries very fast.) Even threaded through reed and heddles at 8 e.p.i., the yarn rolls on the loom beautifully, and the shed is wide open.

Virginia Dobson
San Francisco, California

Warping's in the bag

Two simple ideas have made warping a long, white, fine warp less worrisome for

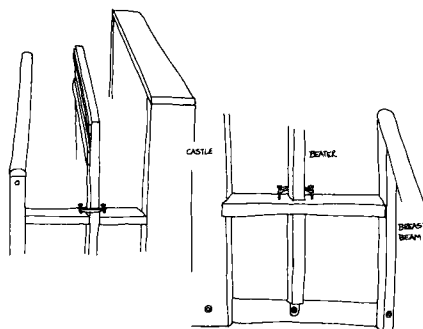

me. 1) I use plastic sandwich bags with slipover seals to temporarily hold my warp chains off the floor and out of reach from my curious cat. This also keeps the work clean during my absences from the loom. I

tie the cross end of the warp chain onto the breast beam and pack the balance of the chain into the plastic bag. 2) I devised a slip-on brace to hold my reed in an upright position as I sley. I cut a piece of 2" by 2" wood the length of the distance between the breast beam and the castle and cut a notch in it where I want my beater to rest. I hammered a nail on either side of the notch. For slewing, I quickly slip the brace into place and stretch a rubber band from nail to nail around the beater frame.

Peggy Coffee
Indianapolis, Indiana

A bench for all reasons

A thought for those who don't have a bench for their looms: I found that the collapsible "Workmate" bench and a cushion is just the right height for me. This bench also gives me a wooden surface for attaching ball, bobbin and skein winders. I even use mine to cinch down my grain grinder when weaving is not in progress and it is bread making time!

Kathy Kromm
Bristol, England

Send your handy hints to "Tricks of the Trade",
Interweave Press, 306 N. Washington Ave.,
Loveland, CO 80537.

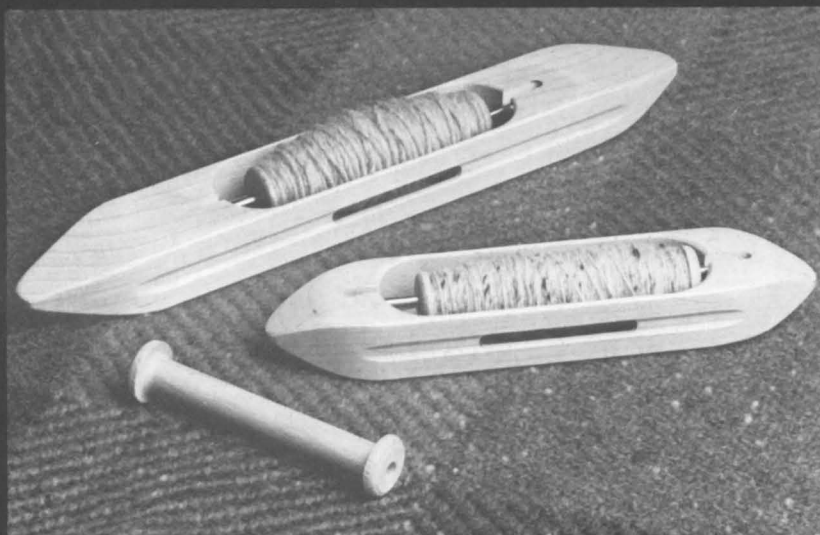

Shuttles . . .

Boat shuttles and hardwood bobbins are just some of the accessories we've designed to make your weaving more enjoyable.

Quality, function and value. Practical handweaving yarns, looms and equipment from the company that makes all three.

Ask for our products at fine handweaving stores. For complete information and a yarn sample, send \$4.00.

Harrisville Designs Harrisville, N.H. 03450

603-827-3333



Swedish Weaving Books in English!

Weave a Weave
Malin Selander
 \$29.95

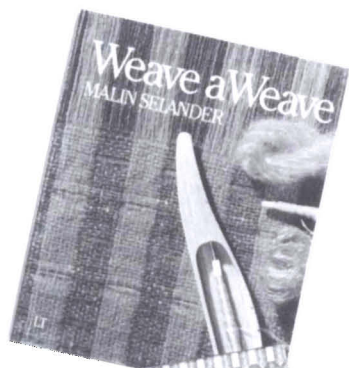

Manual of Swedish Handweaving
Ulla Cyrus-Zetterström
 \$19.95



Damask and Opphämta – with Weaving Sword or Drawloom
Lillemor Johansson
 \$23.95



Rag Rug Weaves Patterns from Sweden
Birgit Wiberg
 \$14.95



Glimåkra Looms 'n Yarns, Inc. 1304 Scott Street, Petaluma, CA 94952
 Phone: (800) 843-9276 or (707) 762-3362

California residents add applicable sales tax. Shipping/handling; add \$2.50 for first book and \$.50 for ea. add. (Canada, add US \$5.00 for first book and \$.50 for ea. add. for airmail and insurance).

VÄV MAGASINET

Scandinavian Weaving Magazine

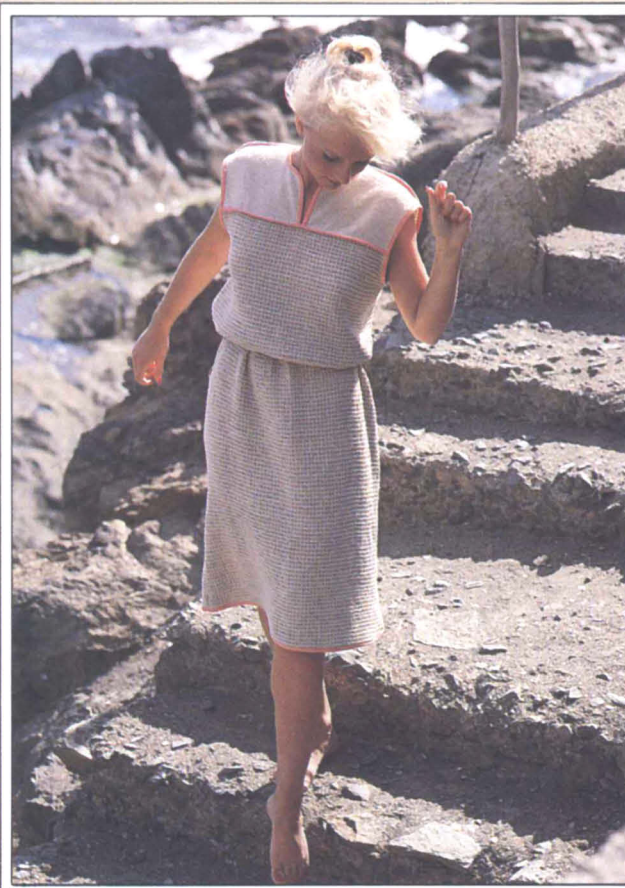

VävMagasinet comes out in four colorful and inspiring issues per year (February, April, August and November). Each issue contains weaving projects designed especially for Scandinavian Weaving Magazine. We offer exciting reading about textile art and weaving, feature courses and exhibitions, and visit individual textile artists, industries, and weaving studios.

Scandinavian Weaving Magazine

is the magazine with the beautiful color photographs.

A one year subscription, now with complete English translation, costs US \$25.00, airmail postage included. Please make all checks and postal money orders payable in U.S. funds to:

Scandinavian Weaving Magazine
 (Glimåkra Looms'n Yarns)
 1304 Scott Street
 PETALUMA, CA 94952
 Tel (707) 762-3362

JOIN US – SUBSCRIBE TODAY!

Books, Etc.

Unlike the Lilies: Doukhobor Textile Traditions in Canada

Dorothy K. Burnham

Royal Ontario Museum, Publication Services, 100 Queen Park, Toronto, Canada M5S 2C6. 1986, 102 pages, 150 b/w photos and diagrams plus 23 color photos. Paper \$24.95 Canadian.

In her preface, Dorothy Burnham, most honored among textile historians, says: 'There is a motto among the Doukhobors, Toil and Peaceful Life'—two elements that should provide a basis for satisfactory living. Although the Doukhobors are strongly pacifist, the peaceful life seems to have eluded them throughout their history. The toil, on the other hand, has been such a reality that I have taken the evocative biblical quotation 'Consider the lilies of the field, how they grow; they toil not, neither do they spin' (Matthew 6:28) and turned it around to provide a title for this account of Doukhobor textile-making: *Unlike the Lilies*. It is my hope that there has been a joy, and possibly a peace, in the spinning and weaving to counterbalance the wearisome toil." Without doubt, Mrs. Burnham

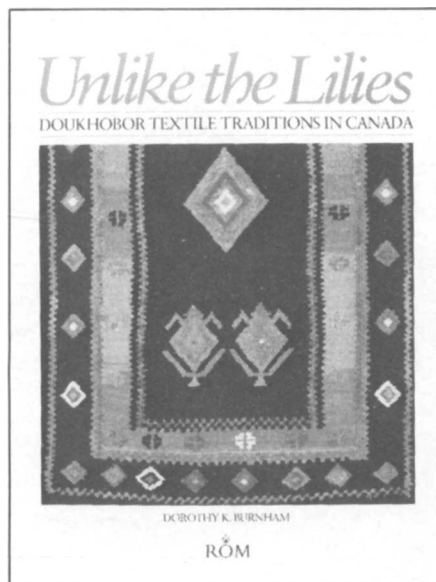

has also experienced both wearisome toil and personal joy during her extensive research in Canadian textile history.

The Doukhobors are a religious sect that rejected the doctrine of the Russian Orthodox church in order to live a simple life of

pacifism, brotherly love, and the sharing of possessions. During the 18th and 19th centuries they lived in various parts of Russia (acquiring assorted textile skills), ending up in the south Caucasus near the Turkish border. During the 1890s, they endured especially dreadful persecutions, and in 1899 and 1900, 7,500 Doukhobors emigrated to Canada, settling in Saskatchewan. Later, a large group moved to the Kootenay region of British Columbia. Life in Canada has not been easy for these people, who have preferred to follow their own way rather than that of mainstream Canada.

Mrs. Burnham gives clear and complete discussions on fiber preparation, spinning and weaving. (The Doukhobor women did not card their wool; instead, they used two distinct types of comb. It was especially interesting to learn how bamboo or hardwood strips are tied into a reed.) The chapter on clothing contains many photographs of the Doukhobors in best dress as well as in work attire. The photos illustrate 19th century Russian peasant costume and also document Doukhobor dress well into 20th century Canada. There is a chapter on household linens with one draft for a

TO FIND OUT MORE ABOUT FLOOR LOOMS, GET THE *New* SCHACHT CATALOG.



BABY WOLF

The Baby Wolf is the most uncompromised small loom available today. It has all the advantages of portability without trading off any of the best big loom features.

The weaving width of the Baby Wolf is a full twenty five inches, enough for most types of projects, including clothing. You have your choice of four or eight harnesses, or you can choose the Four Now - Four Later model which allows you to expand from a four harness to an eight harness loom at any time.

Our unique barrel nut construction and special woodworking joinery assure you of a sturdy and stable loom to weave on. And because of the flexibility of our X frame design, when you are through weaving for the day, you can easily fold the loom up to a depth of just eighteen inches.

Whether space is a problem or not, knowing that a loom will work well for you is really the most important thing. The Baby Wolf's jack mechanisms with its parallel lammas is the same as the one we use on our Standard Floor loom. The tie up cords which are fit easily into slots in the treadles, making changing tie ups effortless. The



The ultra sturdy beater adjusts to accept a variety of reed heights.

The lower side adjusts to raise and lower the shuttle race.

The ultra sturdy barrel nut construction assures you of a sturdy and stable loom to weave on.

The Baby Wolf's jack mechanisms with its parallel lammas is the same as the one we use on our Standard Floor loom.

The tie up cords which are fit easily into slots in the treadles, making changing tie ups effortless.

Floor Looms

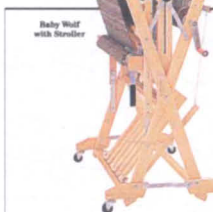

Baby Wolf with roller

Folding the loom up is a cinch, with or without a warp on it. Simply loosen the two side knobs, lift and fold. Your weaving stays neat, the beater remains upright, everything stays together.

Moving the loom around is also easy and with our specially designed Baby Stroller, we offer you the most practical solution for getting your loom anywhere. Hard rubber wheels that will roll across rough surfaces as well as smooth are attached in such a way that as you fold the loom up it is automatically raised onto the wheels. Simply secure the support bars and you are ready to go.

We've designed the Baby Wolf to have the most valuable features of a good floor loom, including parallel lammas, an adjustable beater, a rear friction brake, and two more treadles than harnesses for multiple tie up capability.

The Baby Wolf is made of hard maple, finely sanded and finished with a hand rubbed Danish oil. It comes fully assembled. Just take it out of its box, unfold it, put on the grove bars and heddles, and within an hour you are ready for weaving. Included with the loom are flat steel heddles, a twelve dent reed, three lease sticks, and a loom maintenance manual. A reed with six, eight, ten, or fifteen dents per inch can be substituted for the twelve dent reed.

Options that are available for the Baby Wolf are a sectional beam with two lock sections and a one foot circumference, the Baby Stroller, and ten treadles instead six on four harness Baby Wools. We also have a Baby Raddle with a special bracket to hold it on the loom's rear beam.



Four Harness Baby Wolf

Our elegantly embossed catalog has 24 full color pages featuring our looms and general information to help you decide which floor loom is best for you.

Detail photos show the fine workmanship that goes into our products.

You can get the catalog at one of our dealers or send \$2.00 to Schacht Spindle Co., Inc. P.O. Box 2157 Boulder, Colorado 80306 USA.

Doukhor patterned tablecloth and some good illustrations of fancy work. The chapter on beds and bedding describes various covers and rugs that were made for both the floor and the wooden shelf beds used in the Doukhobors' early days in Canada.

Although this book is directed more to the textile historian than to the weaver, there is much information that will be of help and interest to today's craftsperson. The glossary of Doukhor and Russian textile terms with transliteration into English and the bibliography will be useful to textile scholars. *Unlike the Lilies* is probably the most comprehensive study of Canadian Doukhor textiles that will ever be written.

—Kax Wilson

The Ashford Book of Spinning

Anne Field

Lark Books, 50 College St., Asheville, NC 28801. Paperback, 152 pages, color illustrations, b/w photos. Appendices and index. \$12.95.

Anne Field's introductory spinning book is the result of a commission from the Ashford Company of New Zealand, spinning wheel manufacturers. To some extent, this

colors the form and content of the book. A great deal more attention is given to the kinds and functions of spinning wheels than is usual in an introductory spinning book, although this is all in the context of the different varieties of Ashford wheels. The results are in no way negative, as Field stresses the importance of the functions of a wheel in relation to the yarn spun and provides valid information which applies to any brand of wheel.

While recognizing that a book cannot take the place of learning from an adequate teacher, Field's instruction is directed to the beginner who might have only occasional contact with an accomplished spinner. Her tone is light, relaxed and reassuring; beginning spinners are encouraged to pursue the endeavor, even if their first efforts are less than perfect.

The black and white photographs are the core of the book's teaching. From the first series, showing finger spinning and spinning with a writing pen, the pictures are clear and relevant. As a self-taught spinner from the days when spinning manuals were few and far between, I envy someone learning from this book. It took me forever to understand that it was necessary to pull back when drafting because in the books I was learning from, this was assumed to be general knowledge. The photographs in

this book have arrows to indicate "pull back here" and "move hand forward here." These photographs give a good indication of the pinch-pull-release sequence basic to all spinning.

Attention is given to fleece selection and to the functions of the wheel as related to yarn size, designated as fine, medium and bulky. Consequently, Field not only describes the spinning techniques for these types of yarns, but also suggests the type of fleece which would work best for each and the preferred drive ratio of the wheel. Until fairly recently such information was not included in most spinning manuals.

She also explains the relationship between the size of the yarn (measured in wraps per inch) and the twists per inch and the twist angle. More and more spinners are finding such information important to spinning consistent yarn.

As with most beginning spinning books, and as is expected of a book coming from New Zealand, this one deals primarily with the spinning of wool. Included are sections on fleece selection and fiber preparation. Very little is said about spinning fibers other than wool, but there is brief mention of cotton, silk, flax, mohair and angora.

Field describes several drafting methods, starting with the short backward draft. She emphasizes that most spinners work with a



Schacht Spindle Company products are available through a network of dealers. The knowledge they have to share with you and the services they have to offer make them a great place to purchase our looms and accessory tools. Stop by and visit them and pick up your copy of our new catalog.

Here is a list of some of our dealers. Write to us for the names of other dealers near you.

ALASKA

Fairbanks
Log Cabin Fibers
1074 Mc Grath Rd.
(907) 457-8915

ARIZONA

Mesa
The Fiber Factory
154 W. Main St.
(602) 969-4346

Prescott

The Fiber Shop
208 N. McCormick
(602) 445-2185

Safford

Cotton Clouds
Rte. 2 Desert Hills #16
(602) 428-7000

Sedona

The Pendleton Shop
465 Jordan Rd.
(602) 282-3671

Tucson

Spin 'N Weave
3054 N. First Ave.
(602) 623-9787

ARKANSAS

Eureka Springs
The Spinning Wheel
22 S. Main St.
(501) 253-7064

Heber Springs
Santa's Workshop
2022 Hwy. 25 North
(501) 362-7009

CALIFORNIA

Angels Camp
Kuma Yarn Krafts
1260 S. Main St.
(209) 736-0147

Eureka

The Woolmark
322 5th St.
(707) 442-9272

Indian Wells

Toby's Once Upon A Sheep, Inc.
74-909 Hwy. 111
(619) 340-0480

Mill Valley

Mill Valley Yarn & Weaving
4 Madrona
(415) 383-1650

Sacramento

Rumplestiltskin
1021 "R" St.
(916) 442-9225

San Francisco

San Francisco Fiber
3435 Army St. #222
(415) 821-2568

Santa Monica

Weaving West
2305 Main St.
(213) 399-6063

Three Rivers

Mountain Arts
42268 Sierra Dr.
(209) 561-4716

Torrance

Weave 'n Knit Depot
1313 Sartori Ave.
(213) 618-9171

COLORADO

Boulder

The Weaving & Knitting Shop
1702 Walnut St.
(303) 443-1133

Castle Rock

Burt & Ernie's Mountain Shop
312 4th St.
(303) 688-8813

Estes Park

Chris' Weaving Studio
381 S. St. Vrain Hwy. 7, #9
(303) 586-4624

Golden

The Recycled Lamb
715 14th St.
(303) 278-4117

Loveland

Greentree Ranch Woods
163 N. Carter Lake Rd.
(303) 667-6183

CONNECTICUT

Hampton

Flock, Stock, & Barrel
US Route 6, P.O. Box 11
(203) 455-0272

Newton

The Sheep Meadow
33 Main St.
(203) 426-4155

West Hartford

Treadle One
28 Pheasant Chase
(203) 232-3420

DELAWARE

Dover

Wool Works Farm
Rd 5, Box 134
(302) 653-4361

Newark

Morning Star
7 Elkton Rd.
(302) 453-0774

FLORIDA

Delray Beach

Penelope's Breads & Threads
520 E. Atlantic Ave.
(305) 272-1000

Melbourne

Weavers' Emporium, Inc.
600 Eau Gallie Blvd.
(305) 259-2215

Pensacola

Sheep Thrills, Inc.
501 S. Adams St.
(904) 433-6485

Sarasota

Warped Yarns
2870 Ringling Blvd.
(813) 366-8167

Winter Haven

Country Feeling
642 Avenue B, N.W.
(813) 299-9276

GEORGIA

Clayton

Upper Loft Design, Inc.
Hwy 28
(404) 782-5246

HAWAII

Kaneohe

In Stitches Two
46-305 Ikiiki St.
(808) 235-3775

ILLINOIS

Charleston

EVE (Edna-Verne Enterpr.)
1531 Division St.
(217) 345-6059

Evanston

The Shepherd's Harvest
1930 Central
(312) 491-1353

Lisle

Yarns Unlimited
6458 College Rd.
(312) 416-1566

Naperville

Boll Weave's Ltd.
790 Royal St. George Dr.
Ste. 115
(312) 357-3687

INDIANA

Crown Point

Weaver's Way
1228 N. Main St.
(219) 663-1406

Evansville

Homestead Handweaving Studio
10918 E. Hebmar Dr.
Rt. 10, Box 239
(812) 985-3847

New Albany

The Weaver's Corner
1406 E. Spring St.
(812) 948-0350

New Harmony

New Harmony Weavers
612 Main St.
(812) 682-3578

Terre Haute

Indian Acres Spinner/Weaver
1801 S. 31st St.
(812) 235-2129

IOWA

Iowa City

The Weaving Studio
812 S. Summit St.
(319) 338-1789

KANSAS

Minneola

The Wool Winders
E. Hwy. 54
(316) 885-4603

KENTUCKY

Lexington

Yarn & Fiber Studio
380 S. Mill/Dudley Sq.
(606) 255-5151

LOUISIANA

Chalmette

Rose Line Inc. Weaving Studio
(504) 279-4066

2906 Fenelon St.

(504) 279-4066

MARYLAND

Baltimore

The Weaver's Place Inc.
4900 Witheredsville Rd.
(301) 448-2428

Frederick

Forestheart Studio
21 S. Carroll St.
(301) 695-4815

Potomac

The Weaving Wagon
8505 Brickyard Rd.
(301) 299-8972

See page 17 for additional listings.

combination of methods depending on individual dexterity level, the wheel, the fiber, etc. This is a non-arbitrary and realistic approach. Perhaps because of a different terminology used in New Zealand, what Field calls "medium draft" appears to be what is most often referred to as the "unsupported long draw" in this country.

There is information on spinning novelty yarns, felting and wool dyeing. The chapter entitled "Questions and Answers" appears to include useful bits the author could not quite fit in elsewhere. The book includes two extended appendices on sheep breeds and the various Ashford wheels.

Although an otherwise excellent book, I have a few minor criticisms. The drawings which illustrate how to dress a distaff are amateurish and inadequate. It is not clear why these drawings are used at all when everywhere else photographs are used to illustrate any given process. Overall the book has a distractingly fussy appearance. This is due primarily to the format used to present the many pictures. On some pages they are arranged horizontally, on others vertically, and the text is not positioned consistently in relation to the photographs. Also, while the projects for which instruc-

tions are given are nice, they are not exceptional.

The text is clearly and entertainingly written. As mentioned previously, although commissioned by Ashford, this does not intrude on the presentation. Any

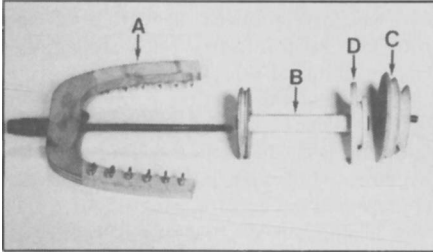

Double belt flyer, bobbin and spindle whorl: A—flyer; B—bobbin; C—spindle whorl; D—bobbin whorl.

tendency towards "advertisement" is limited to the appendix in which all the Ashford wheels and equipment are described. Anne Field has written a modest yet thorough spinning manual. Her goal was to present clearly and concisely the basic material necessary for a beginning spinner. She has accomplished this very well.

—Brucie Adams

To the Finish

Lura Jim Bogdanor

Self-published. 23 Cardigan Dr., Ferguson, MO 63135. Ring binder notebook, 220 pages, b/w photos, line drawings. \$17.95 plus \$2.25 postage.

For weavers who do not like to sew, this book offers ideas and instructions for creating garments from one or more rectangles using only basic knitting and crocheting skills. The projects shown are simple to construct but may be upgraded by your additional talents.

The first chapter gives instructions for finishing the edges of a rectangle, and then offers photographs and diagrams for six blouses, five tops, five jackets and one vest.

The next few chapters discuss how to pick up the stitches on the handwoven rectangle, how to knit or crochet the additional rectangles that are used in some of the projects, and how to put the resulting projects together. Also included are suggestions for edge finishings. There is even a chapter on buttons, frogs, belts and other trims.

TO FIND OUT MORE ABOUT WEAVING TOOLS, GET THE *New* SCHACHT CATALOG.



We offer a wide selection of types and sizes of shuttles. All of them are made of hard maple and are finely sanded and hand finished with a Danish oil. Our best shuttles are also available in oak.

Boat Shuttles
For weaving with fine or medium yarns the boat shuttle is the best there is. The web is wound onto a bobbin which then feeds off automatically as the shuttle travels across the warp. The result is smooth rhythmic weaving. Our boat shuttles are beautifully shaped and well balanced, a pleasure to use. The open bottom design and spring loaded shaft make changing bobbins quick and easy. We have four sizes for you to choose from. The smallest, the eleven inch slim, is used for fine yarns; the two middle sizes, the eleven inch regular and the thirteen inch, and the largest fifteen inch shuttle are good for fine and medium yarns. We make all sizes of our boat shuttles out of oak as well as maple. If you're looking for the perfect gift for your favorite weaver, an oak boat shuttle will be a most satisfying choice.

Bobbins
We offer three sizes of plastic bobbins for boat shuttles: four, five, and six inches long. They have specially designed ends for trouble free release of the yarn as the shuttle slides across the shed.

Throughout the weaving process you are handling your shuttles more than any other single piece of equipment. Since you will be spending so much time using your shuttles it is worthwhile to find the ones most comfortable for you. Factors that should go into shuttle choice include type of weft yarn to be used, the size of your loom's shed, the width of the warp, and, of course, your personal and aesthetic preference.

Shuttle Size	Weight	Material
11" Slim	1.5 oz	Oak
11" Reg	2.0 oz	Oak
13" Reg	2.5 oz	Oak
15" Reg	3.5 oz	Oak
11" Slim	1.5 oz	Maple
11" Reg	2.0 oz	Maple
13" Reg	2.5 oz	Maple
15" Reg	3.5 oz	Maple

Ski Shuttles
Made to hold medium to heavy yarns, the twenty-four inch ski shuttle is designed so that the yarn is wrapped horizontally around the top of the ski. This leaves a smooth bottom for sliding easily across the warp.

Rag Shuttles
These are large, sturdy shuttles for holding very heavy wefts, be it rags or very fat yarn. They come in lengths of fourteen and twenty inches.

Rag Shuttles
This is a beautiful shuttle carved from a single piece of hard maple. Good for medium to heavy yarns, our rag shuttle is twenty inches long.

Stick Shuttles
The most versatile and least sophisticated of all shuttles, stick shuttles will work for any weaving. Our ones are available in nine, sixteen, twenty, twenty-four, thirty, and thirty-six inch lengths as you can use the ones most suited to your project. Choose one that is slightly longer than the width of your warp.

Belt Shuttles
This small eight inch shuttle is similar to a stick shuttle but somewhat thicker. It has a beveled edge for beating in the web when weaving narrow bands, table looms, card-weaving and narrow back strap bands (all for belt shuttles since no other beating mechanism is provided).

Over time you will find that owning a variety of shuttles will prepare you for any weaving project you decide to undertake. Feel them, look at them, try them out. Choose the ones that appeal to you, for you'll be working with them for a long time.

Our new catalog is a resource. Clear descriptions and lots of information to help you select the right tools. Pictures you can almost hold; all in full color. An embossed cover that is so beautiful, you'll probably want to frame it. You can get one at any of our dealers or send \$2.00 to Schacht Spindle Co., Inc. P.O. Box 2157 Boulder, Colorado 80306 USA.

Chapter 5 tells you how to measure yourself and how to apply those measurements to the pattern you are using.

The ring binder that the book comes in is large enough to accommodate many project sheets and samples, and a generous amount of notepaper is included.

Although there is much useful information in the book, I feel that some problems exist with organization and production. The book is not arranged well; it does not read smoothly, and the sections do not fall in a logical order. A lot of material reads more like suggestions and is too casual. More detailed instructions would be more helpful. Also, many of the photographs are poor and difficult to discern, even with the help of the text.

I disagree with some of the author's instructions, in particular, her method of constructing darts on the shoulders to create a slope. Most handwoven fabrics are fairly heavy; a shoulder dart, of the size she recommends and pressed according to her directions, would fit poorly. In my experience, the dart should be cut, opened, overcast and then pressed. Also, the pattern must have a curve on the armhole edge so that the shoulder will have a smooth line.

I also think that the ease allowance she suggests in the designing of garments would be fine for commercial fabric, but it is not enough for handwoven fabric. You will need 4" to 6" more fabric if it is for a jacket, and more yet, if it is lined.

—Betty Keeler

Tartans: Their Art and History

Ann Sutton and Richard Carr

photography by David Cripps

Arco Publishing, Inc., New York, 1984. 192 pages, index, bibliography, 80 color and 100 black and white photos and illustrations. \$19.95.

From a structural point of view, tartans are of limited interest, since they typically are woven in a 2/2 twill or, on occasion, in plain weave. Their variations, now numbering over 1500, rely entirely on an arrangement of colored stripes in the warp, which is duplicated in the weft. Ann Sutton and Richard Carr use a grid to efficiently convey stripe directions for over 200 traditional tartan designs. Swatches, as in *The Structure of Weaving*, are photographed life-size, an approach that I feel worked

better in *The Structure of Weaving*. Some of these fabrics look blatant and coarse. One wants to see them at a greater distance, or better yet, as costume. However, the weaver who wishes to reproduce a clan tartan will probably appreciate the clarity of detail.

Tartans, no doubt written as much for the general public as for the weaver, supplies basic information on spinning, dyeing and history, as well as a map of the clans of Scotland, information on the Scottish Tartans Society and the Highland Games, and a list of family names with their respective clans. I wish the authors had given more space to the history of textile production in Scotland. There are, however, two wonderful pages, originally published in 1933, that describe Kilbarchan, the last colony of tartan weavers. I love this story of a man who was able to weave a double-faced tartan:

I watched him at work on a rug of Grant tartan, the reverse side of which was a MacLean. It was an extraordinarily complicated process. 'How on earth do you do it?', I asked. 'Well, my eye's on the MacLean and my mind's on the Grant.'

—Lynne Giles



Schacht Spindle Company products are available through a network of dealers. The knowledge they have to share with you and the services they have to offer make them a great place to purchase our looms and accessory tools. Stop by and visit them and pick up your copy of our new catalog.

Here is a list of some of our dealers. Write to us for the names of other dealers near you.

MASSACHUSETTS

Arlington
Batik & Weaving Supplier
393 Massachusetts Ave.
(617) 646-4453

Harvard
Fiber Loft (Bare Hill Studio)
Rte. 111 (Post Office Building)
(617) 456-8669

Medfield

Woolworks
67 North St.
(617) 359-4666

North Dartmouth

Wildflower Fiber Studio Ltd.
61 State Rd. Rte. 6
(617) 999-3771

MICHIGAN

Birmingham
The Weaving Room Gallery, Ltd.
251 Merrill
(313) 540-3623

Frankenmuth

Rapunzel's Weaving & Yarns
780 Mill St.
(517) 652-8281

Northville

Traditional Handcrafts
154 Mary Alexander Ct.
(313) 349-7509

Rockford

Weavers Shop & Yarn Co.
39 Courtland
(616) 866-9529

Royal Oak

The Golden Heddle
1602 Rochester Rd.
(313) 547-9159

Traverse City

Mariposa Handweavers
541 W. Front St.
(616) 946-4201

MINNESOTA

Minneapolis
Creative Fibers
5416 Penn Ave. S
(612) 927-8307

MISSOURI

Columbia
The Weavers' Store
11 South 9th St.
(314) 442-5413

Springfield

Woolly Weavers
1805 E. Seminole
(417) 887-8090

St. Charles

Craft Place
506 S. Main
(314) 723-9398

NEW HAMPSHIRE

Henniker
The Fiber Studio
Foster Hill Rd.
(603) 428-7830

NEW MEXICO

Albuquerque
Village Wools
3801 San Mateo N.E.
(505) 883-2919

Santa Fe

Santa Fe Weaving Center
713 Canyon Rd.
(505) 983-5003

Thos

Rio Grande Weavers Supply
116 B Paseo Del Pueblo Sur
(505) 758-0433

NEW YORK

Charlton
Woodside Weavers
R. D. 3, Jockey St.
(518) 399-7991

East Port, L.I.

Fiberphilia
506 Montauk Hwy.
(516) 325-1313

Fort Plain

Windhover Wools
Rte 168 Rd. #1
(315) 823-1071

Henrietta

The Fiber Shop
3140 E. Henrietta Rd.
(716) 334-1440

NORTH CAROLINA

Asheville

Earth Guild
One Tingle Alley
(704) 255-7818

Burlington

Helen Gant - Handweaving
713 E. Willowbrook Dr.
(919) 226-3330

Charlotte

A & N Designs
1612 Elizabeth Ave.
(704) 375-2364

Dillsboro

Riverwood Handweaving
U.S. Highway 441
(704) 586-9418

OHIO

Belpre
Needlenuts' Hut
Village Plaza, Clement Ave.
(614) 423-KNIT

Canton

Merrie Lamb
3811 Lincoln St. E.
(216) 488-2544

Carroll

A Touch of Americana
3820 Columbus-Lancaster
N.W.
(614) 756-4458

Chardon

Hart's Haven Handwoven
369 Park Ave.
(216) 286-2181

Cincinnati

Peach Mt. Studio, Inc.
7754 Camargo Rd.
(513) 271-3191

Pepper Pike

Cellar Weaves Studio
27976 Belgrave Rd.
(216) 831-1963

OREGON

Bandon

Westerly Webs
170 Second
(503) 245-8780

PENNSYLVANIA

East Berlin

The Mannings
1132 Greenridge Rd.
(717) 624-2229

Holidaysburg

The Spinner Weaves
16 N. Juanita St.
(814) 695-1661

SOUTH CAROLINA

Greenville

The Weaver's Knot
121 Cleveland St.
(803) 235-7747

TEXAS

Austin

Hill Country Weavers
918 West 12th St.
(512) 474-6773

Clint

Two Cotton-Woods
150 Jeff Jones
(915) 851-3412

Dallas

Spindletop Yarn Shop
4008 Villanova
(214) 691-2489

El Paso

Mayatex Co.
5330 Gateway East
(915) 778-6175 &
(800) 527-2358

Goliad

Just For Ewe
111 Court House Sq.
(512) 645-2146

Houston

Craft Industries
#78 Woodlake Sq.
(713) 789-8170

McKinney

The Loose End
301 E. Louisiana
(214) 548-0614

VIRGINIA

Alexandria

Sylvia Designs/Fiber Station
1117 King St.
(703) 549-3634

Chester

Weaving Lady Studio
4001 Cresthill Rd.
(804) 748-9036

Timberville

The River Farm
Route 1, Box 401
(703) 896-9931

WASHINGTON

Seattle

Weaving Works Inc.
5049 Brooklyn Ave. N.E.
(206) 524-1221

WISCONSIN

Grafton

Grafton Yarn Store
1300 14th Ave.
(414) 377-0344

Madison

Weaving Workshop
920 E. Johnson St.
(608) 255-1066

Milwaukee

The Wool Works, Inc.
1812 N. Farwell Ave.
(414) 278-8838

See page 15 for additional listings.

Students and this teacher talk about what weaving means to them.



WEAVING

Better Than Bridge

by Deborah Chandler

"So what if I love [weaving]," I ask myself. "Does that give me the right to convince someone else that they do?"

IN HER January/February 1987 "Professional Pursuits" column, Connie LaLena gave us an interesting look at the rise and fall of weaving over the years. She concluded with a most important opinion: if weaving is to continue for us as we have known it, we must increase our ranks. Only through growing numbers will our support system — suppliers of equipment, yarns, and information — be able to stay in business and keep providing the choices we have come to expect and enjoy. In addition, education of the nonweaving public to appreciate — and purchase — handwoven goods is critical to our economy.

I have struggled for at least a decade with the whole idea of proselytizing weaving. "So what if I love it," I ask myself. "Does that give me the right to convince someone else that they do?" When I owned a weaving shop, I resolved the question by reasoning that anyone who walked through my door was interested by definition. As a teacher, I've had to

continue wrestling with it. As a teacher of mostly beginners, I need not weavers but weavers-to-be.

As always, my students themselves have provided answers to my dilemma. And they've asked me to share their ideas with all of you. Why have *they* decided to learn to weave?

At the start of most of my workshops, I ask everyone to write down ten words that represent what weaving means to them. The lists vary, and a group of 15 people will usually produce around 80 different words. Most common are *color* and *creative*. Least common are *loom*, *yarn*. Interesting!

Perhaps because so many weavers are in the helping professions (nurses, teachers, therapists, librarians, social workers, and of course mothers, to name a few), the lists often revolve around the idea of **therapy for oneself:**

relaxation, enjoyment, identity, spirituality, pride, centered feeling, accomplishment, reward, therapy, self-pleasure, peace, satisfaction,

— continued on page 20

How Does a Parallel Countermarch Work?

The counter-march is a system of moving harnesses by which each harness moves either up or down when a treadle is depressed. Experienced weavers agree that the counter-march is the best system yet and always gives the best shed, even with a high warp tension. Also, all warp threads are pulled either up or down and therefore receive equal tension when the shed is made.

The Traditional Counter-march System

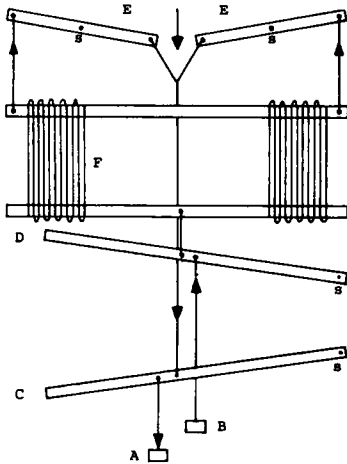

Every harness is connected directly to lam D or directly to lam C by means of balances E. The points S are pivots. When treadle A is pushed down, the connecting lam C and balances E move down in the middle and lift the harness F at the outer ends. When pushing down treadle B, the connecting lam D and harness F go down. Every treadle has to be connected to all harnesses of the loom.

The Parallel Counter-march:

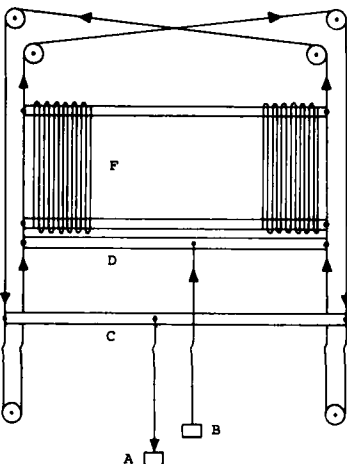

An endless cord is running over 6 rollers so that the inside cords move opposite to the outside cords.

The harness F and the upper lam D are tied to the inside cords, the lower lam C to the outside cords. When treading down A and lam C, the harness F moves up. When treading down B (tied to lam D) the harness moves down.

Many weavers feel that the advantage of the greater shed of the Counter-march is outweighed by the disadvantage of double the number of tie-ups as compared with jack-style looms. The texsolv loop cord has really eliminated those objections by simplifying and speeding up the tie-up process greatly.

The Advantages of the Parallel Counter-march

The traditional counter-march has lams which move at the side pivots. The connected treadles differ in their movement and also in the amount of power needed to push them down.

The closer the treadle is to the pivot, the more force is needed to push it down. The narrower the loom is, the more noticeable is the effect. The parallel counter-march system doesn't have this problem. The lams always move parallel, so every treadle requires the same power to move it. This feature is particularly important with a counter-march system, because

treading combinations (pushing more than one treadle at a time) are not possible. Therefore, the number of treadles dictates the number of combinations which can be tied up at one time; and only with a parallel system is it possible to run treadles almost the whole width of the loom. They all work the same.

The Louët Hollandia

The Hollandia uses the parallel counter-march system which you can see is easy to understand and easy to tie-up. Another feature exclusive with the Hollandia is the spring-tensioned breast beam, which is adjustable to compensate for very delicate spidery webs or tough inelastic rug warps.

The heddles and tie-up cords are of the Swedish texsolv system: quiet, strong and non-stretching. The Hollandia is available in two widths, 110cm (43 inches) and 130cm (51 inches) as a four harness with six treadles, and is convertible to eight harnesses with ten treadles. Extra treadles are available, and the Hollandia will accommodate up to fourteen. The frame is made of Ramin hardwood finished in a clear, semi-gloss lacquer. Loom depth is 39" open, 30" folded; height 49". Accessories include matching bench, shelf, raddle, sectional warp beam and more. Write for free catalog.

Louët Sales
Box 70
Carleton Place, Ont.
K7C 3P3



New, Exciting, Better Than Ever!

Greater selection, a wider range of colors, and our commitment to quality at a surprisingly affordable price.

Top of the Lamb

This 100% Wool yarn comes in a range of the newest colors and is offered in 3 weights:

- #1 - Single-ply Worsted Weight Yarn
- #2 - Multi-ply Sport Weight Yarn
- #3 - Single-ply Warp Yarn

Lamb's Pride

Choose from several rich beautiful tones in this blend of 85% Wool/15% Mohair with a lustrous sheen and a silky, soft hand. Available in a Single-ply Worsted Weight or Single-ply Bulky Weight.

Cotton Top NEW!

The newest of our yarns this multi-ply 50% Wool/50% Cotton blend is a terrific year-round yarn in bright, vibrant colors.

All yarns are available in Natural Colors. All of our yarns are specially spun for beauty, softness and washability. And, our new 1986/87 range of colors offers new glorious shades for you to choose from.

For Complete Color Card
Send \$2.50

Brown Sheep Co., Inc

Route 1
Mitchell, Nebraska 69357
(308) 635-2198

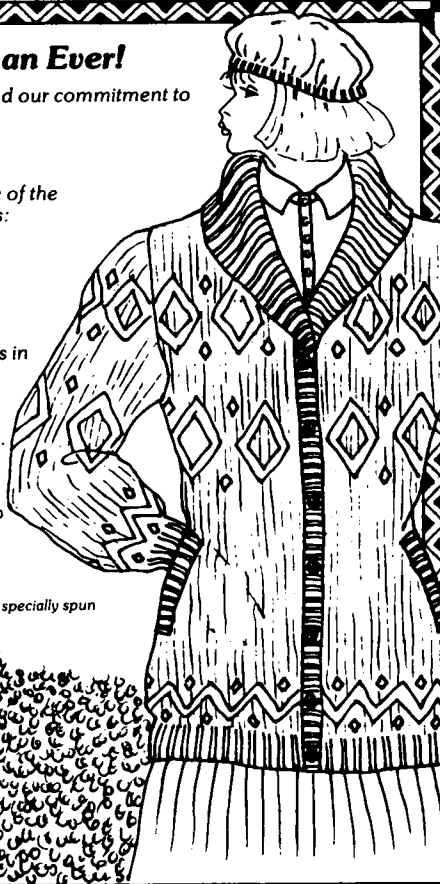

YOUR WEAVING TEACHER

(continued from page 18)

energy, meditation, serenity, calm, rest, self-expression, enrichment, grounding, fulfillment, personal, leisure, individuality, escape, release, stress relief, love of life.

Personal growth is closely akin to personal nurturing, and adds a few other dimensions:

stretching, challenging, learning, new ideas, creativity, study, identity, hard work, intrigue, stimulation, discovery, adventure, growth, understanding, progress, commitment, achievement, coordination of thought, possibility, intensity, focus, expansion, imagination, re-creation, exploration, surprise, goals, determination, planning, motivation, feeling, thought, discipline.

Other words reflect the strong sense of community that is available: interrelationships, cooperation, interesting people, women, fellowship, interaction, friends, people, unity, social, sharing.

For a number of weavers, the ties to other cultures and to the past are important:

heritage, tradition, Sweden, Shakers, continuance with the past, history, ancient, old world.

Certainly there are many dichotomies:

simplicity/complexity, hobby/occupation, excitement/calm, energizing/energy consuming, expensive/profitable, stressful/stress-relieving, isolation/sharing.

Lest we think this bed of roses has no thorns, here are a few:

frustration, backache, fears, scary, forbidding, tiring.

For some, the word *mathematical* also goes on this list.

There are many more categories that could be derived from these lists of words, including art, the five senses, musical analogies, and practicality. The last I'll suggest here is what I'd call fun, or a sense of humor:

fun, playing, hopes, magical, delight,

and, finally,

better than bridge, and a step up from darned socks.

Some years ago I believed that any kind of creative work would offer

Scott's!

The source of the '80s,
for the fiber of the '80s:

Rayon!

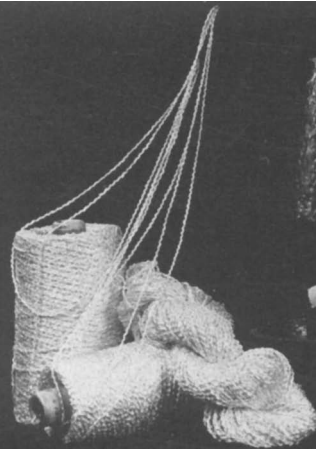

Rayon has come of age. It's the yarn for all seasons. And Scott's, as it has for so many years, has the fiber that matters.

GALAXY . . . a novelty textured yarn with brilliant sheen and dressy elegance in romantic pastels and starlight brights.

CAMELOT II . . . a sleek, clean-cut rayon braid in jeweled brights and dramatic darks with eye-appealing accents.

MILAN . . . a subtly textured rayon bouclé with delicate surface effects in mellow earth tones and citrus brights.

Ask about other rayons and rayon blends. Scott's sample set \$10.00 — wholesale inquiries only. (Include resale # and 2 other proofs of business)

Closeouts available by request.

Scott's Woolen Mill, Inc.

P.O. Box 1204, 528 Jefferson Avenue, Bristol, PA 19007
Telephone: (215) 788-2328

For orders only: Toll-free 1-800-225-4661 (except PA and AK)

most of the benefits implied in my students' word lists. To some extent, I still think that is true.

However, I have since learned that weaving is so vast and all-encompassing that I now believe its potential really does exceed that of other media. For example, woven pieces can be utilitarian as well as artistic, in a phenomenal array of ways; stained glass is pretty much limited to use in or near windows. The therapeutic value of weaving for emotional well-being is probably shared by most other art forms, but its value for physical therapy seems to be endless.

No matter what you need, you can probably get it from weaving. That's amazing.

I believe with all my heart that peace must be a grassroots movement, and this brings me to wonder what would happen . . . if large numbers of people could find a means to personal peace.

What does this have to do with anything? For me, this potential is the major reason I stay with weaving. Let me come at the topic — "Why weave?" — from another direction for a moment.

I believe that world peace is desirable. Peace on a personal level does not depend upon agreements between the world powers or on the actions of politicians; it does depend on my own sense of value and worth. When I am comfortable, centered, at ease with myself, I don't lash out at others; when I am frustrated, unhappy, off-balance, I do. It's that simple. The peace in my world depends entirely on the peace I feel within myself.

I believe with all my heart that peace must be a grassroots movement, and this brings me to wonder what would happen — in homes, in nations, in the world — if large numbers of people could find a means to personal peace. If they could relax at their looms, express themselves creatively, and feel stimulated and fulfilled through such endeavors, I believe it would make a difference in the world.

People tell me that weaving provides an avenue of goodness for them. They say that time at their looms gives them what they need to go forth positively, effectively, and lovingly into the world. They've said this to me, and shown me, so many times that I believe it, for them and as a potential for anyone else who wants to weave.

And so I think, "I know that weaving isn't right for everyone. But it is for some, maybe for many." And so I want to make sure that weaving

remains available for everyone who wants it, that they can get the information and supplies and support they need to become weavers, and maybe become peaceful. Getting this potential out there, in all the ways I can, is my contribution to world peace, the healing of this planet, and the health of every child of life.

Deborah Chandler travels extensively around the U.S. spreading the word about weaving. She regroups and relaxes at her Boulder, Colorado home.

A WEAVER'S GARDEN

Rita Buchanan

6" X 9" / 224 pages/color photos/illustrations (cloth).

Cotton, flax, indigo, soapwort, lavender, teasels.

A WEAVER'S GARDEN describes the properties, history, botany, and practical applications of dozens of fascinating plants.

- Plant fibers for spinning and stuffing
- Plants for natural dyeing and how to use them
 - Herbs that repel clothes moths
- Woody shrubs for traditional textile tools
- Soap plants for cleaning textiles
 - How to plant a fiber garden
 - And much, much more

Beginning or experienced gardeners, in climates mild or fierce, can tuck in a few plants or design a whole garden that's useful and fun! Illustrations, diagrams and color photographs are included.

Order yours today!

Available at local weaving and spinning shops or from Interweave Press for \$16.95 (\$19.45 including postage).

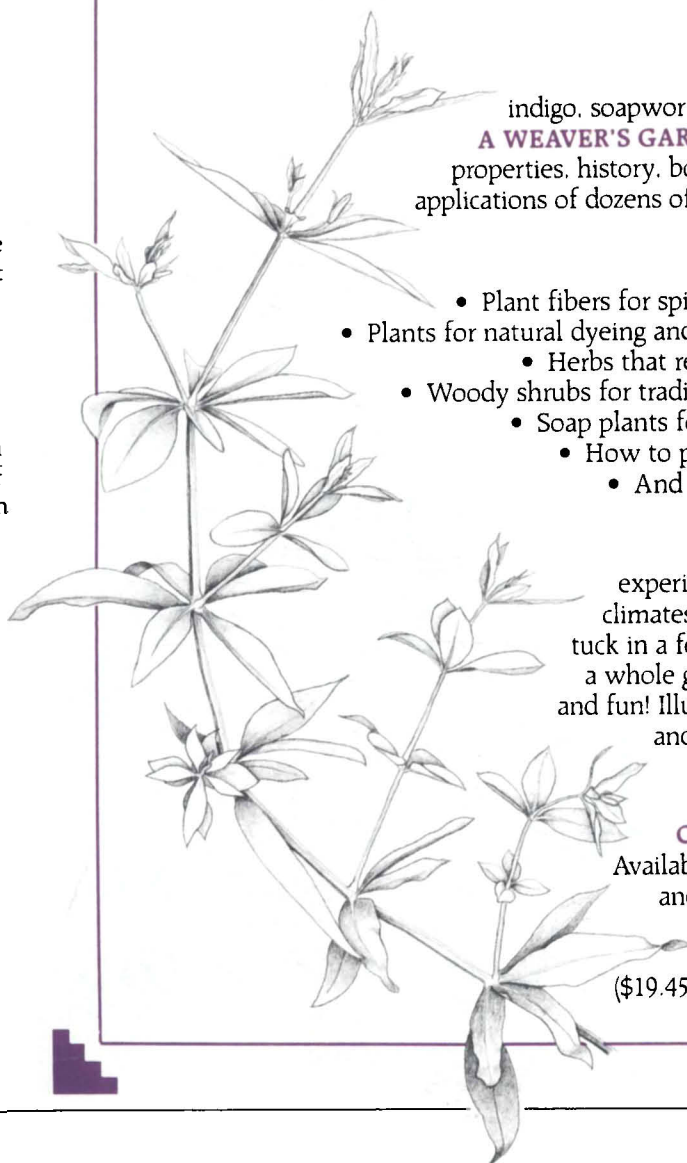

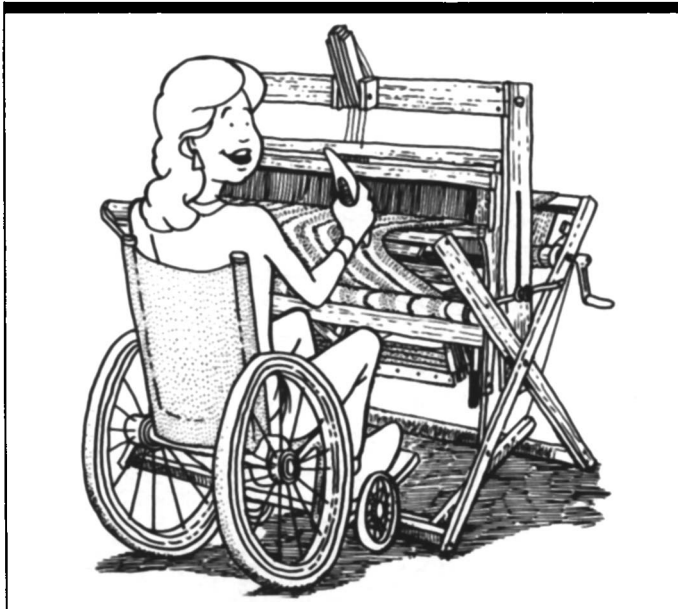

Special Looms for People with Special Needs



If you have a disability which requires changes to be made in our looms, contact us. We will be glad to discuss your individual needs.

Write or call or stop by one of our dealers for more information and a copy of our catalog (\$2.00 Ppd). Schacht Spindle Co., Inc., P.O. Box 2157 Boulder, CO, 80306. Phone (303) 442-3212.

FREE FREIGHT

On orders of any Schacht, Leclerc or Tools of the Trade Looms in the Continental U.S.A.

For further information contact:

The Fiber studio



Foster Hill Rd., P.O. Box 637, Dept. HW
Henniker, NH 03242
603-428-7830

AD-A-HARNESS LOOMS®
—Traditional Quality—
AD-A-CAD/CAM SYSTEMS™
—Trendsetting Innovations—

C
E
L
E
B
R
A
T
I
N
G

O
U
R

50th

Y
E
A
R

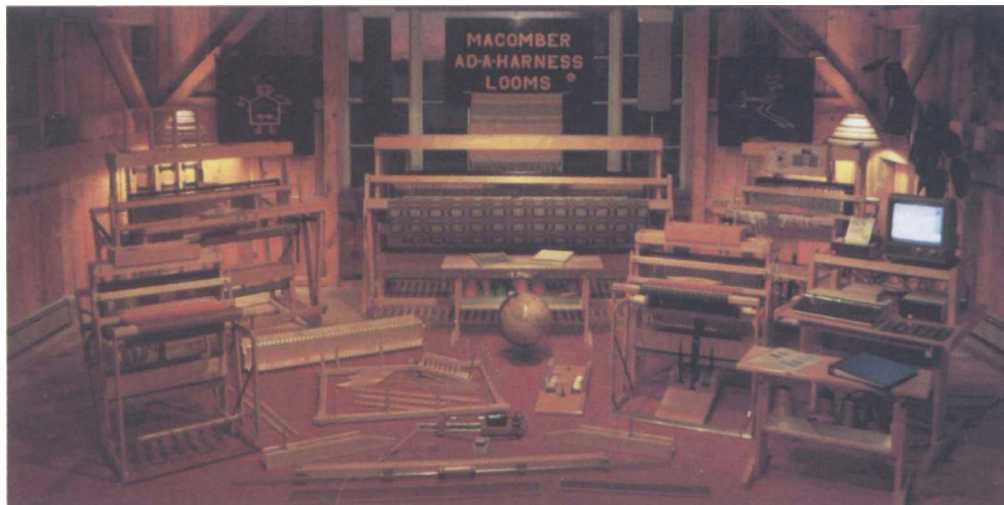

MANUFACTURED BY

MACOMBER LOOMS

P.O. Box 186 Becch Ridge Road - York, Maine 03909 - 207-363-2808

— ESTABLISHED 1936 —

Call or write today for our new catalog.



IDEA NOTEBOOK

*No more
hot hands —
a handwoven
skillet holder!*

Here's a simple-to-weave project that's sure to be a welcome addition to any kitchen. It's a great little item to weave for party favors or for sale at the annual bazaar. Since each holder requires only a 7" square of fabric, this is a good way to use leftover warp.

This cheerful skillet holder was designed by the Pirkanmaan Kotityo Oy Company, and features bright stripes of poppana bias-cut fabric strips. The black 12/2 cotton warp peeks out from the weft-emphasis stripes and makes a pleasing contrast to the bright weft colors.

The warp sett is 12 e.p.i.; p.p.i. is about 10. This fabric should be thick but not stiff.

Materials needed: Warp — 12/2 cotton at 1029 yd/lb (this is Helmi Vuorelma Tuuli, black #097 available from Eaton Yarns and Schoolhouse Yarns). Weft — poppana bias-cut fabric strips at 50 yd/lb (this is Pirkanmaan Kotityo Oy Poppana in sage green #27, lavender #36, hot pink #32, and red orange #29 available from Schoolhouse Yarns). In addition, you'll need cotton lining fabric slightly smaller than the poppana square, cotton bias tape (cotton lining fabric can be substituted), matching thread, and a sewing machine.

Assembly is fast and easy: With right sides together, fold poppana fabric in half and sew a side seam. Cut a piece of bias tape 6" long (or make your own). Fold tape in half to make a loop and sew into the seam at the end of the tube with the loop inside and the raw edges of the loop even with the raw edges of the fabric. Taper the edges of the seam to form a rounded end. Cut a piece of cotton lining fabric slightly smaller than the poppana fabric. Fold this in half, right sides together, and sew a side seam. Turn the poppana fabric right side out, and then place the lining fabric tube over this tube (right sides of both fabrics facing each other). Sew lining and poppana fabric together at bottom edge. Slip the lining off the poppana fabric and sew the other end of the lining fabric; this seam, which will be tucked inside the skillet holder, will have its raw edges on the fabric's right side. Push the lining up into the poppana tube. Voilà! — a nifty skillet holder that will please any cook. □

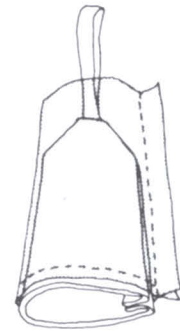

EXCLUSIVELY SILK:

The Silk Tree

A DIVISION OF SELECT SILKS INC
DEPT. H. BOX 78, WHONNOCK, B.C., CANADA V0M 1S0

Over 50 quality silk yarns and fibres
mail order only
samples \$4.00



Simply Cotton.
Simply Beautiful.

100% cotton yarns for knitting, weaving, and crochet in contemporary colors—pastels, multicolors, earthtones, brights, and whites. **Weights, sizes and textures**—flakes, thick-thins, bouclés, nubbies, ribbons, chenilles, plains and perles. **On cones or skeins.** Plus patterns, tools, books, and fibers for spinning.

To receive your beautiful 1987 Cotton Clouds mail-order catalog with hundreds of all-cotton yarn samples, send \$5. to:

Cotton Clouds
Rt. 2, DH 16-R
Safford, AZ 85546



COTTON CLOUDS

America's leading mail-order supplier of 100% cotton yarns



**You have the loom
— we have the yarn**

The leading yarnsupplier of Scandinavia offers you:
Yarn of the highest quality. Low prices.

Please send \$ 4.00 for samples of 650 colors in cotton, wool, linen, hemp and cottolins (75/25)

Enclosed free price list.

C.L. BLOMQVIST AB

S-510 20 FRITSLA
SWEDEN



WORK OF ART

Norwood and Cranbrook looms are works of art in themselves. They're beautiful as fine furniture in your home, beautiful to the handweaver's sensitive touch, beautiful as the means to a creative end.

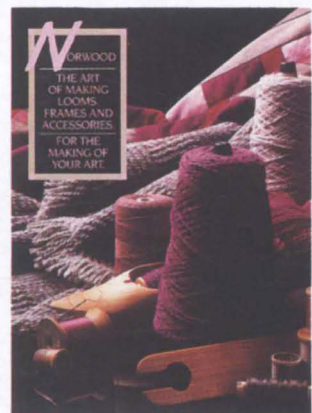

IT'S NEW. For your copy of the new Norwood catalog, featuring looms, frames and accessories, send just \$1 and this coupon (or your name and address) to: Norwood Looms Box 167 Fremont, MI 49412

Name _____

Address _____

City _____

State _____ Zip _____

A



News & Events

by Dale Pettigrew

NEW YORK CITY: "Interlacing: The Elemental Fabric"

"Interlacing is the term for all fabric constructions in which each element passes over and under elements that cross its path. This simple definition incorporates a vast range of structures and form. . . . Interlacing is one of the earliest and most universal of all inventions."

This definition serves as introduction to the recently published volume, *Interlacing: The Elemental Fabric*, by Jack Lenor Larsen with Betty Freudenheim, and to the exhibit of the same title curated by Larsen at the American Craft Museum. Larsen has assembled over 150 examples of traditional and contemporary interlaced forms from 40 countries, among them vessels, masks, toys, sculpture and jewelry. The collection demonstrates how the earliest plaited fabrics provide a basis for some of the newest expressions in fiber, clay and metal. Works by 35 contemporary artists are included.

The exhibit is on view at the American Craft Museum, 40 West 53rd Street, New York City, through July 17. National tour dates will be announced.



COLUMBUS, OHIO: "Garment Design: In Celebration of Body and Soul"

One-of-a-kind, art-to-wear apparel will be featured in exhibitions and events through the month of June in Columbus, Ohio. Exhibits will include the National Invitational Exhibition, a statewide juried exhibition of hand-made garments and theatrical costumes by Ohio artists, an exhibition of kimonos from the Meiji-Taisho eras, and "Zandra Rhodes: A One-Woman Show".

Other events include a lecture by Zandra Rhodes, a wearables trunk show, and a symposium: "The Roots of Wearables". Two workshops focusing on garment design will also be offered: "A Course in Wearable Imagery", by Louise Todd Cope, June 11-12, and "Body and Style: Designing Wearables that Complement Your Appearance", by Albertje Koopman, June 15-16.



BOSTON: "The Art That Is Life"

Late in the 19th century, John Ruskin and William Morris led a visionary movement in England against the enslavement of the factory system and the deluge of shoddy, factory-made goods. In an effort to restore "joy in labor" and pride in craftsmanship, they promoted hand-crafts and the philosophy of self-sufficiency.

Over 225 objects that exemplify the range and creativity of the Arts and Crafts Movement are on display in an exhibit, "The Art That Is Life", at the Museum of Fine Arts, Boston. Textiles, ceramics, stained glass, jewelry and iron-works, as well as photographs and murals depicting architecture and landscaping, are included. Four room settings which dramatically illustrate the Movement's idea of design integrity conclude the exhibit. A catalog of essays and color and black and white photographs accompanies the exhibit. For more information contact the Museum of Fine Arts, Boston, 465 Huntington Ave., Boston, MA 02115. (617) 267-9300. □

Outline.

If you can't find the yarn you want here, you probably can't find it. We offer one of the largest assortments of colors and textures. So it stands to reason you stand a better chance of finding any yarn with us. To simplify your search, use this coupon to send for the individual color chart of each yarn style you're looking for. Or send \$5.00 and we'll send you our complete line.

Please send me the following:

- NOVI-CHENILLE** (100% Cotton — 500 yds./lb.)
Spun with a strong rayon warp so you can weave it as warp or weft. Dyed to match our most popular colors, you will want to weave it with Nordica, Brite and Novi-Cotton. 50¢
 - NOVI-WORSTED™ 2/10's** (100% Pure Worsted Wool — 2,800 yds./lb.)
Wonderfully soft, amazingly strong and long wearing. This wool worsted yarn is fast-dyed to unusually beautiful colors, some pastel, others deep and full. Perfect for wearable fabrics. 50¢
 - NOVI-WOOL 2-PLY** (100% Pure Wool Worsted — 1,650 yds./lb.)
The ultimate pure wool worsted weaving yarn spun in the Swedish tradition. Full spectrum of colors, some natural, some dyed, all washfast. 50¢
 - NORDICA** (75% Rayon 25% Linen — 1,875 yds./lb.)
A classic among hand weaving yarns, Nordica is a versatile yarn texture which combines the brightness of rayon with the strength of linen. 50¢
 - BRITE** (100% Rayon 950 yds./lb.)
The brilliantly clear colors and the durable 2-ply construction make Brite an ideal weaving yarn which also has uses in many other textile crafts. 50¢
 - NOVI-COTTON™ 2 PLY** (100% Cotton - 1,100 yds./lb.)
Primitive spun Novi-Cotton is plied so you can weave it as warp or weft. The full range of matte colors provide an exciting textural contrast when interwoven with our Nordica, Brite, or Novi-Slub. 50¢
 - NOVI-SLUB COTTON** (75% Rayon 25% Cotton - 1,200 yds./lb.)
The handspun Haitian cotton look gives a wonderful texture to weavings. We have created it with rayon and natural cotton fiber. The unusual color range includes soft earthy pastels and muted bright tones. 50¢
 - 6/3 NATURAL LINEN RUG WARP YARN** (600 yds./lb.)
Spun from long flax fiber, our 6/3 natural linen rug warp is strong and smooth. A perfect warp yarn for rug and tapestry weaving. 50¢
 - 10 LEA 2-PLY LINEN** (100% Linen — 1,500 yds./lb.)
A versatile linen yarn, our 10 Lea 2-Ply is line spun for extra strength and durability. Its many uses include weaving, crochet and stitchery. The color line provides a full spectrum of coordinated shades. 50¢
 - 16 LEA 2-PLY** (100% Linen — 2,400 yds./lb.)
When a fine linen yarn is needed, use our 16 Lea 2-Ply for table linens, clothing, wall hangings and casements. 16 Lea 2-Ply comes in natural color and in bleached white. 50¢
- I enclose 50¢ for each sample card.
 I enclose \$5.00 for all sample cards.

WHOLESALE ONLY: Schools, Shops and Designers

Shop name or school _____
Address _____
City _____ State _____ Zip _____

NOVITEX, INC.
250 Esten Avenue
Pawtucket, R.I. 02862

Spin it, Wind it, Weave it. You need it—we have it!

“Viking” Swedish Floor Loom

Glimakra's newest — a jack loom available in 36" and 48" weaving widths (4 harnesses, 6 treadles). Solidly constructed; smooth, quiet operation. Clean, even shed. An addition to the line of world-renowned Glimakra® counter-march looms.

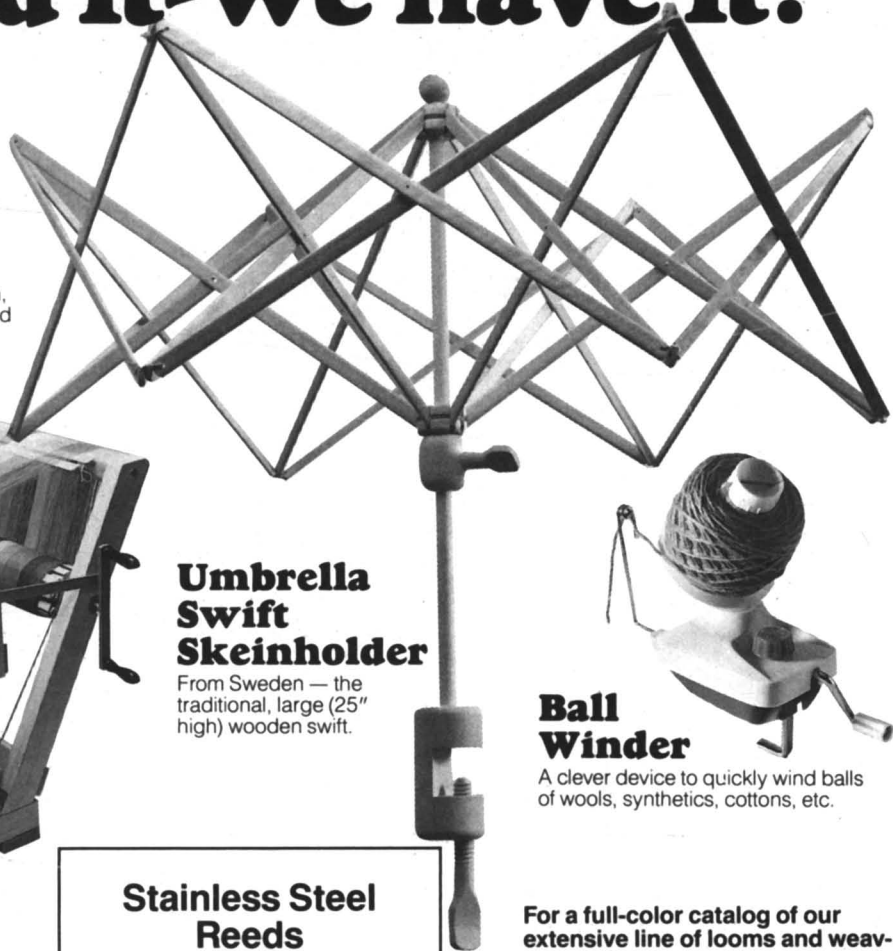

Umbrella Swift Skeinholder

From Sweden — the traditional, large (25" high) wooden swift.



Ball Winder

A clever device to quickly wind balls of wools, synthetics, cottons, etc.

Stainless Steel Reeds

Has the cost of stainless steel reeds kept you from using them? Check our prices on the new VIKING reeds — you'll be pleasantly surprised!

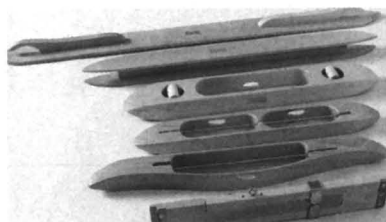

For a full-color catalog of our extensive line of looms and weaving accessories, send \$2.50. For a yarn sample book, containing over 1000 color samples of wools, cottons, linens and cottolins (50/50), send \$10.

COMPARE PRICES AND ORDER OUR WEAVING EQUIPMENT FROM YOUR WEAVING STORE. IF THERE IS NO LOCAL GLIMAKRA DEALER, YOU CAN ORDER DIRECT FROM US — Call TOLL FREE 1-800-THE YARN. (California residents call 1-707-762-3362)

Bobbin Winders from Sweden

Well-balanced, smooth-running metal bobbin winders. Small (#11), Large (#21), Lace (#31).

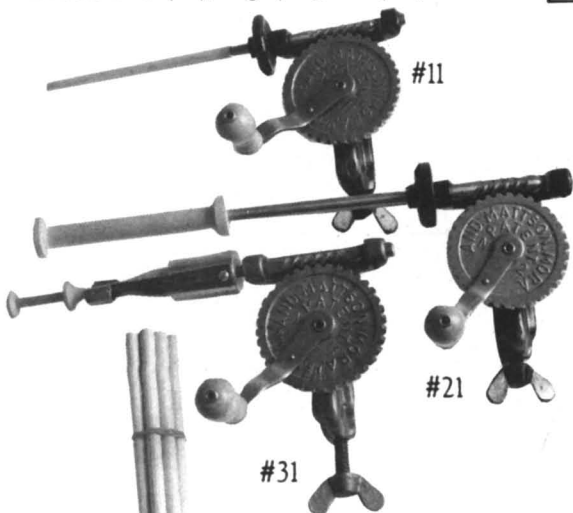

Paper Quill Bobbins

Use with #11 winder.

Wooden Temples and Shuttles

Over a dozen sizes available.

TEXSOLV Heddles / Tie-Up Kits

World famous; from Sweden. Over a dozen heddle sizes available.



Glimakra Looms 'n Yarns, Inc.

A subsidiary of Viking Trading Company
1304 Scott Street — HW14
Petaluma, CA 94952

Dealer Inquiries Invited.

TACKY-TO-TASTEFUL

Finishing Touches for Household Linens

by Louise Bradley

JOSH, ONE OF our favorite nephews, has always had that extra twinkle in his eye, the sort of sparkle that signals good fun to young friends and trouble to parents. When he was about four years old, his mother reported happily that at last Josh was making good progress toward acceptable behavior. She was certain he now knew right from wrong. It was just that, unfortunately, he usually chose the wrong. In a way, it is similar with finishing techniques. An essential beginning is to know "right" from "wrong" — to recognize the distinction between "quick and dirty" and "heirloom". You are then in a position to decide where on this continuum between tacky and tasteful you want your work to be.

Most of us have enough pride in workmanship to aim higher than shabby. Because of the time and material we put into warping and weaving any table mat, napkin or runner, we try to protect our investment (and our edges). At the far end of the spectrum are those very special pieces woven with no regard for time or trouble, weavings that far exceed minimum standards to become a juror's pleasure, an heir's pride. We cannot expect to create many of these in our weaver-lives.

The real decisions are in the middle between the dreadful and the sublime. Once you eliminate work which is *obviously* awful, the "rights" and "wrongs" of linen finishing are not clear and indisputable. Individual circumstances influence judgments. A production weaver must select an economically quick yet secure finish. A hobby weaver has more freedom to select a finish with challenge, satisfaction, or recipient in mind. In any situation, there are usually several acceptable techniques.

Tacky-mat. First, as a reference, let us consider a "tacky-mat". Our example is really *unfinished*; it has not been washed or pressed. I made that mistake — once — at the first guild sale in which I dared participate. An experienced weaver had the courage to point out to me that it was poor practice, bordering unethical, to sell unwashed table mats. She was right. Almost all hand-wovens improve in appearance and texture with washing (this assumes intelligent precautions for delicate fibers), and laundering also eliminates possible unpleasant color and size surprises for the customer. A good pressing, with attention to keeping the warps and wefts straight and perpendicular, is also important.

Our "tacky-mat" is also poorly *finished* in the sense of final details. The fringe has been knotted carelessly and without thought. Fringe is a poor choice with yarns that unply or disintegrate. When used, fringe should be

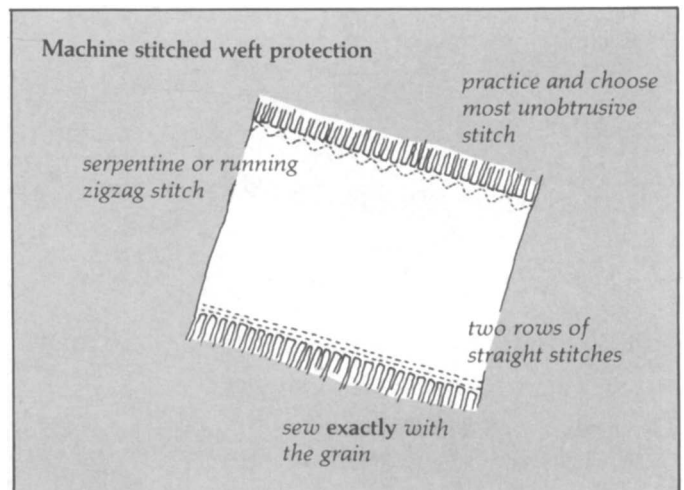
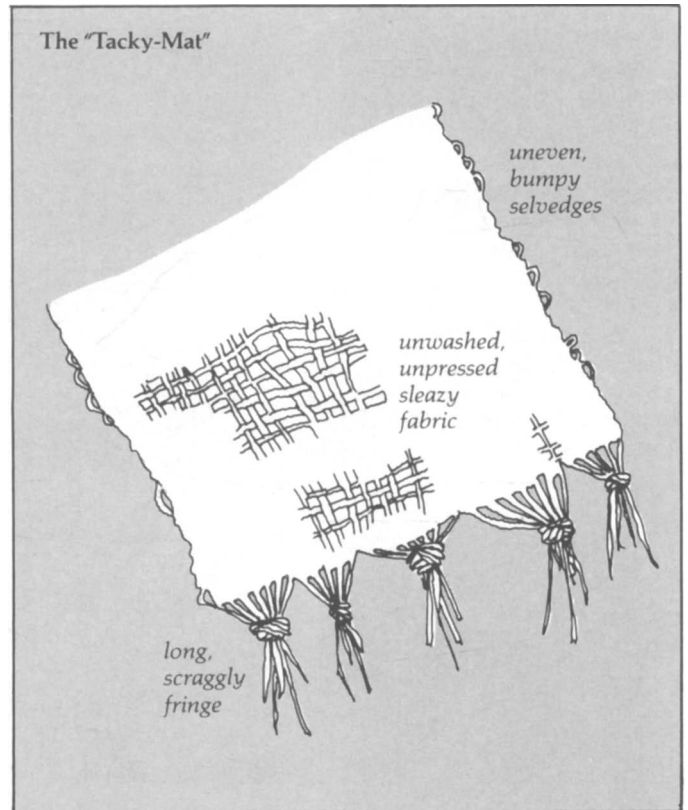

cut straight at an appropriate length (about 3/4" to 1" for table mats). Warps should be tied in small equal groups, the knots evenly aligned with the weft and not conspicuously bulky.

Uneven selvages, a bugaboo of the inexperienced, are hard to ignore on an article that will be laid parallel to a straight table edge. If they are dreadful, you could press the selvages under, taking care to make the new edges straight, then hand stitch them in place. While not the most desirable finish, it's a passable corrective measure, especially feasible on finer fabrics. It will not work on bulky materials, such as rag runners, where there is no substitute for an evenly turned weft. Don't worry, straighter edges will come eventually with practice and care.

The overhand is (k)not all. With unknotted fringe, some form of hand or machine stitching can be used to keep the weft from raveling. Production weavers often use the machine because it is quick and sure. Stitches will be nearly invisible if they are sewn exactly on the fabric grain with a thread of the same color and value

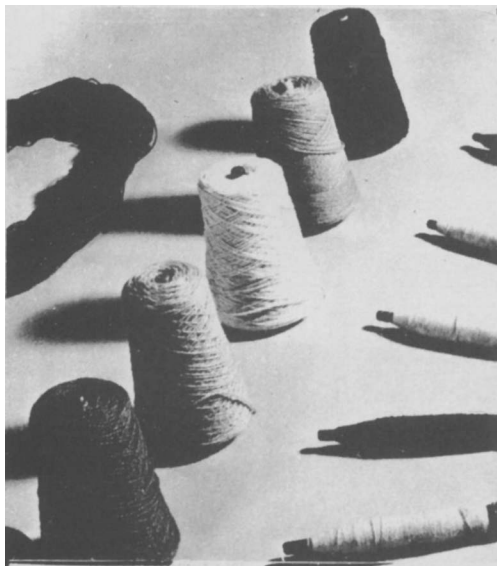
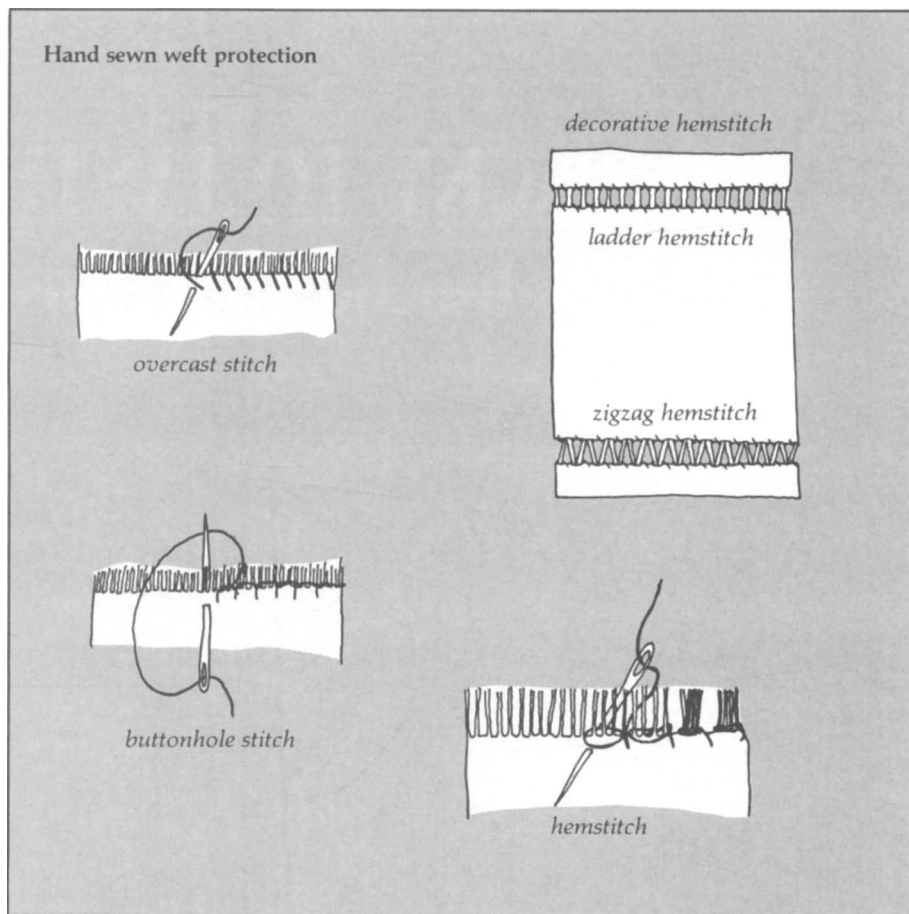

FORT CRAILO YARNS

<i>CRAILO-RYA</i>	570 yd./lb.
<i>CRAILO-SPUN</i>	700 yd./lb.
<i>CRAILO-LITESPUN</i>	1700 yd./lb.
<i>CRAILO-ZEPHYR WORSTED</i>	4900 yd./lb.

and now

CRAILO-COTTON YARN

seventeen colors in cotton
8/2 PLY — 3 PLY — 4 PLY — 5 PLY — 6 PLY

*** You Owe It To Yourself *
To Use Top Quality Yarn**

Spun, twisted, dyed especially for
handweaving **Finest virgin wools**
Fast dyes **Moth-proofed**

***NEW LOCATION**

28 colors — dyed and natural
4 weights — all for both warp and weft

DIRECT FROM MILL TO YOU
in one-half pound cones

IMMEDIATE DELIVERY
Postage added to invoice

Complete sample line: wools 2.00
cottons .80

MILL END YARNS ALSO AVAILABLE

FORT CRAILO YARNS CO. P.O. Box G, Dept. 3, Newburgh NY 12550. (914) 562-2698.

as the weaving yarn. Do practice on a scrap of the handwoven fabric to test color and to become skilled at sewing exactly straight along the wefts. Try several machine stitches, and pick one that promises security and near invisibility. If your sewing machine does not do fancy stitches, a double row of straight stitches will do nicely. As a *general rule, I dislike machine stitching on handwovens* because the result, even with perfect execution, can be jarringly visible. However, if without the speed of machine stitching you couldn't consider making handwoven linens for your family, then by all means *do it*—and don't feel guilty!

Hand stitching above the fringe is more elegant than either knotting or machine sewing. You might choose buttonhole stitching, overcasting or hemstitching, all of which are most easily worked on the loom while the warp is under tension. (See the General Instructions section of this magazine for specific directions for hemstitching.) In every case, practice and good judgment will yield a suitable stitch length and placement. As always, straight, even stitches are critical. If you wish an extra elegant finishing touch, consider doing more rows of hemstitch near the ends of the mat. Two rows directly in line, with the same warp grouping, create a ladder effect; offsetting the stitches in adjacent rows by half a warp group gives a zigzagged appearance. Check any simple embroidery stitch booklet for yet more ideas.

Hems. Table linens with hems look more tailored and formal than fringed cloths. Hem width is a matter of personal choice; an inch is often used, but a very narrow rolled hem could make best sense in some situations. Observe the work of other weavers and commercial examples to develop your own preferences for pleasing proportions. If the main weft of the woven piece is very bulky, consider using a finer yarn, perhaps the warp, in the hem area. Weave the width of the hem (or, for even less bulk, twice its width) with a finer weft. Equal hems on all edges, with mitered corners, is a classy finish, especially useful for square linens. (For more on mitering see this column in the Jan/Feb 1985 issue of *HANDWOVEN*, page 86.)

— continued on page 30

Gentle Soft Strong

Icelandic yarn is strong enough to use as singles in the warp and gentle enough to let you weave a memory.

We provide custom cones in any weight up to one pound.
Call for consultation on your next project.

For more information, see your dealer, or call or write

Louise Heite

Importer of Icelandic fleece, yarn, and rovings

P. O. Box 53, Camden, Delaware 19934, phone 302 - 697 - 1789

Send \$5 for samples, including a spinnable sample of fleece.
Dealer inquiries welcomed.

Icelandic Wool is special



C L A S S I C
E L I T E
Y A R N S, I N C.

MOHAIR, COTTON, ALL AMERICAN WOOL, PURE CASHMERE, SILK, LINEN,
NATURAL FIBRE BLENDS — AVAILABLE ON CONES AND SKEINS FOR
HANDKNITTING AND WEAVING. DEALER INQUIRIES INVITED (617) 453-2837.
CLASSIC ELITE YARNS, INC. 12 PERKINS STREET, LOWELL, MA 01854

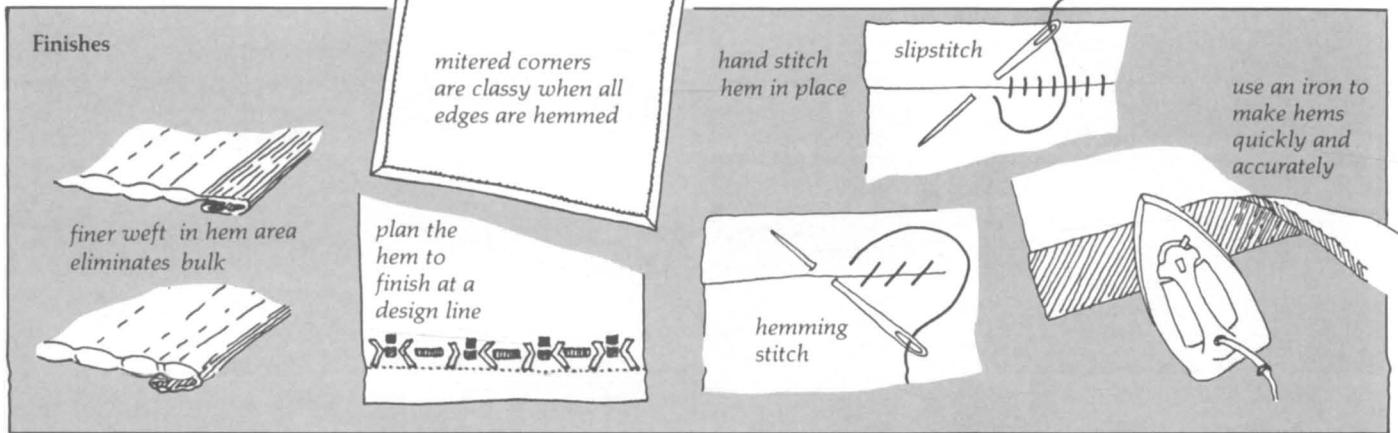

Some of the most handsome hand-woven linens are hemmed just to the edge of a design element. The hem seems to be a harmonious part of the total (not merely an afterthought) if it folds to the edge of a lace pattern, to the end of a stripe, or to a double row of hemstitching.

The task of hemming is accomplished more easily and neatly if you use an iron to turn the fabric. Take great care to make each turn along a single thread, exactly on the grain. On finely woven cloth, it is sometimes helpful to pull or remove a weft to mark the turn line. After pressing, neatly hand stitch the hem in place. A slip stitch is least visible, but a finely sewn hemming stitch is also acceptable.

... and on beyond, with class. Please consider these suggestions just a beginning. If table linens are your creative forum, there are even more wonderful finishes to try. Consider hemstitching the sides of the piece or making fringe along the edges as the weaving progresses. Think about a rolled hem with crocheted edging worked over it, or a piece proudly signed with embroidered initials and date in the corner. Nothing is so elegant or eloquent as a simple hand-woven linen beautifully finished with loving touches. The choices are yours.

For further ideas on fine finishing of household linens see the forthcoming Interweave Press Design Collections: *Terrific Table Toppers* #10 and *Heirloom Linens* #11.

Louise Bradley is the proud aunt of Josh and two dozen other sparkly nephews and nieces – Bradleys, Babcocks and Silvers – who have scattered themselves all around the country.

THE MAKER'S HAND

A Close Look at Textile Structures

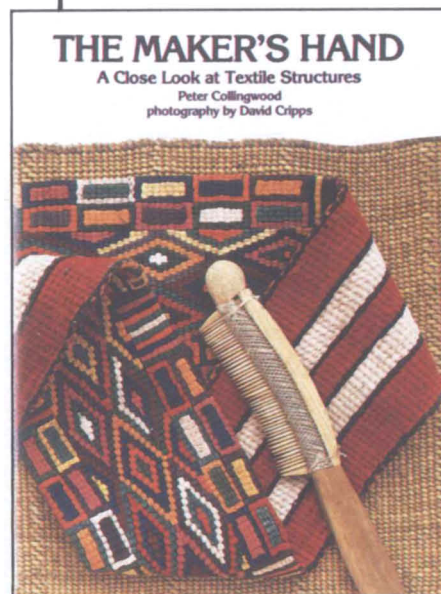

Here it is! Peter Collingwood's long-awaited study of textile structures from around the world. **The Maker's Hand** includes 80 noteworthy pieces, chosen for their beauty and unique composition of materials and structure.

Striking page and cover design, superb photographs and exquisite technical illustrations make this book a "coffee table" showpiece. Collingwood's thorough notes on the history, ethnography and specific techniques used in each textile make it an unparalleled study of our textile heritage.

This is one reference you won't want to be without. Order yours today! Available from Interweave Press for \$29.95 (\$32.95 including postage) and local weaving shops. To order, please see the Book Order Insert inside this issue of **HANDWOVEN**.



160 pages/8½"×11"/color photography
illustrations/hardbound

ASHFORD SPINNING WHEELS



Discover the luxury of weaving with your own handspun.

Try an Ashford Spinning Wheel soon.

Write for a free color brochure and an Ashford Dealers list.

CRYSTAL PALACE YARNS
(A Division of Straw Into Gold)
Dept. HW7
3006 San Pablo Ave.
Berkeley, CA 94702

The COUNTRY CRAFTSMAN

is a careful reproduction Flax Wheel made here in New England with a few changes to keep modern spinners happy.

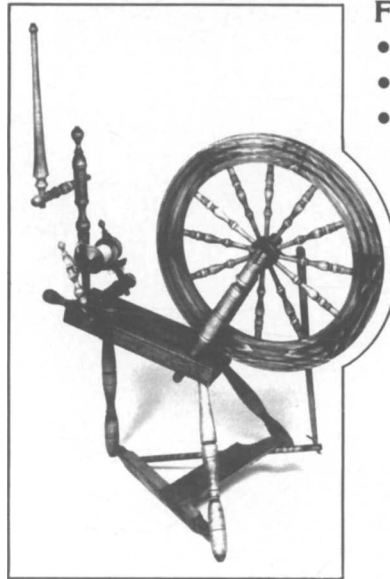

FEATURES

- Double Drive System
- 1/2" Oriface
- New Larger Bobbin
- Step Pulley with 13-22-1 and 10-22-1 Ratios
 - Laquer Finish
 - Easy Change of Ratios with Step Pulley

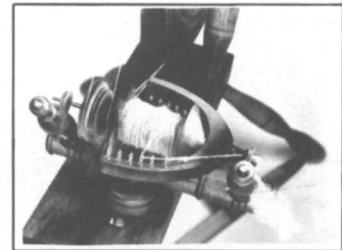

Look and Try It at a Dealer Near You • For more information write to

The COUNTRY CRAFTSMAN
P.O. Box 412 Littleton, MA 01460 617-486-4053

Dealer inquiries invited.

TAPESTRY & COLOR WORKSHOP WITH GUNNEL ORESJO

August 10 - 15, 1987

Gunnel Oresjo has taught in both Sweden and the United States. Her tapestries are inspiring. Her training in Sweden, with Malin Selander and at Handarbetets, qualify her well.

Workshop includes 6 days of instruction in tapestry technique and in safe, easy dyeing for glamorous colors. All yarn and dyes included in the workshop price — \$95. Please write or call for information. Classes held at Greentree Ranch. Size is limited.

FREE COLORADO VACATION PACKAGE

Visit Colorful Colorado and our Greentree Ranch Weaving and Spinning Shop. Send us two 22-cent stamps for maps, visitor's guide, etc. We'll include a 10% yarn discount coupon useable when you visit the shop.

SMOOTH COTTON WARP-HANDY 2 LB. CONES - 4, 6, & 8-PLY

Most weavers need some basic cotton warp on the shelf. Greentree offers high quality 4, 6, and 8-ply on handy 2-lb. cones at just \$15 each, postpaid. Yardages - 3,000, 2,000, and 1,500 per lb. respectively.

PHONE ORDERS WELCOME - -
VISA, MASTERCARD, AMER. EXPRESS

GREENTREE RANCH WOOLS

163 N. Carter Lake Road • Loveland, CO 80537
Phone: 303-667-6183

FREE YARN SAMPLES - FREE NEWSLETTER

Yarn bargains are always available at Greentree - fine odd-lot yarns at closeout prices. We send samples in our FREE NEWSLETTER. To "subscribe", send four self-addressed, stamped envelopes (the long kind) to Greentree Newsletter, 163 N. Carter Lake Road, Loveland, Colorado 80537.

WARP EASIER WITH CORRUGATED

It's hard to imagine how much easier it is to warp using roll corrugated between layers on your warp beam. Warp rolls on smooth; no sagging strands to ruin your pattern. 10-yard rolls: 36" wide, \$14 ppd; 48" wide, \$18 ppd.

GREENTREE RANCH WOOLS, HW587
163 N. Carter Lake Rd., Loveland, CO 80537

Please send me items checked, I enclose \$ _____ OR credit card number & expiration date.

- ___ Rolls of ___-inch corrugated
___ Cones of ___-ply warp @ \$15 ppd
___ Free Spinning Catalog (SASE)
___ Fiber Samples (\$3 refundable)
___ Yarn Samples (\$5 refundable)
___ Free Colorado Vacation Package (44c)

Name _____

Address _____

City _____ Zip _____

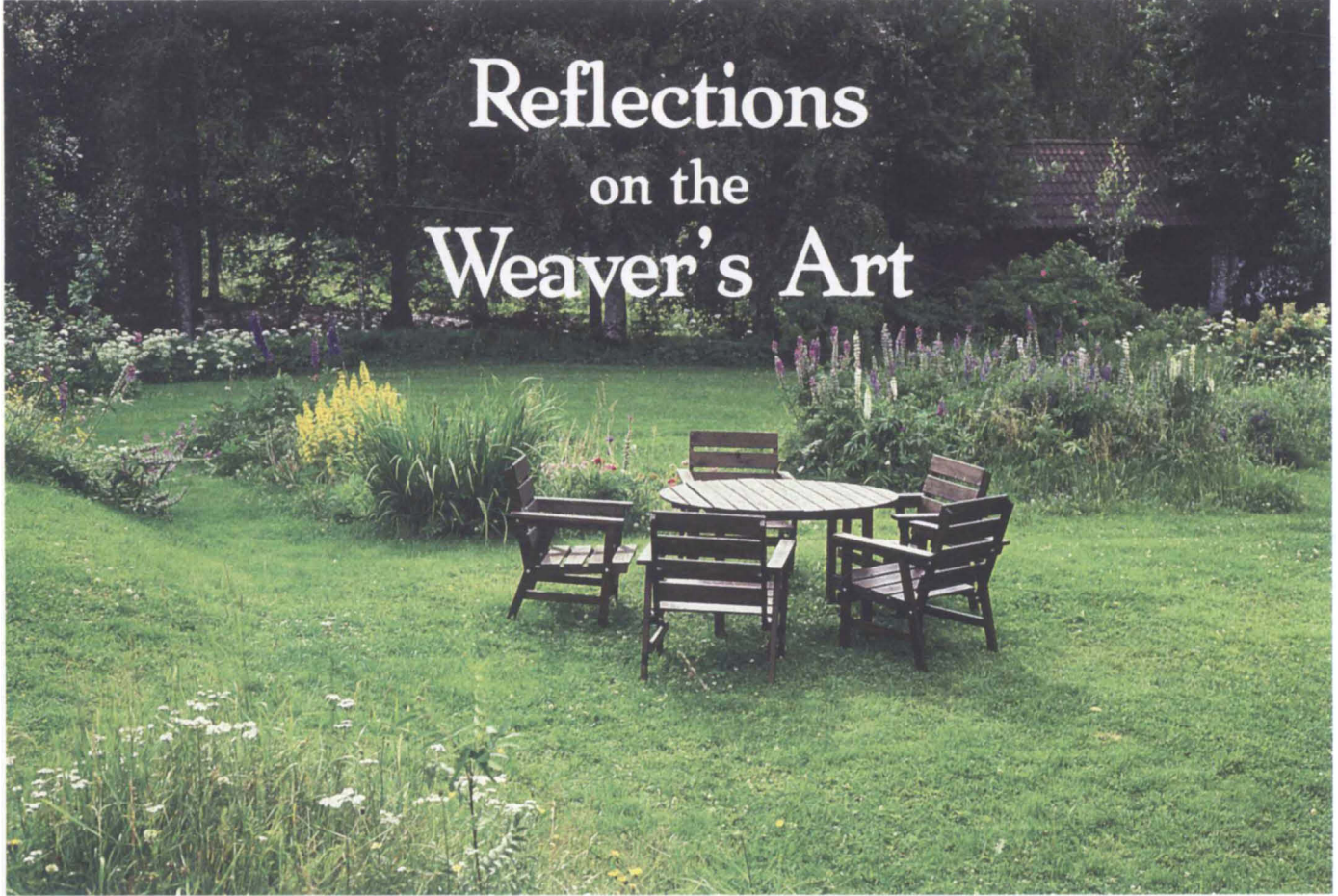

Reflections on the Weaver's Art

by Charles Talley



SEVEN YEARS AGO I went to Scandinavia for the first time. Could it have been that long ago? I had arranged to take a summer course in weaving then, never thinking I'd return. But I have—a number of times in the intervening years. Each time I found myself going back for a slightly different reason: to give some lectures, to gather material for a book, to lead a tour, and finally, to live there for a period of two years. Now I'm back in California and things have come full circle, or at least seem to. Each lucky trip to the Nordic countries has provided its own insight and experience for me, but it's as if each succeeding layer of experience were transparent. I can still see through each level to that first visit, so fresh and free and filled with sweet sensations.

I remember best the faces of the weavers I met. Especially the older ones, the ones who had endured. And prevailed. While Finland was threatened with invasion by the Russians, Dora Jung sat at her loom in her Helsinki

studio weaving with paper thread. Synnøve Anker Aurdal faced similar challenges in occupied Norway. Just after the War's end, Asgerdur Buadottir returned to her native Iceland from Denmark with a loom. She had decided to be a textile artist, the first and only one in her country for nearly 20 years. At the same time in history, Edna Martin assumed the reins of leadership at Sweden's renowned Handarbetets vänner workshop in Stockholm while simultaneously heading the textile department at Konstfackskolan, the country's leading art academy. She had determined to revitalize her country's tapestry tradition single-handedly, and in the succeeding three

The Scandinavians have a need to create beauty for everyday living. We see this reflected in the photograph, above, of a well-tended summer garden, and at right, in the pillow and upholstery fabrics.

PHOTO: CHARLES S. TALLEY



decades achieved her goal. Meanwhile, in Denmark, Vibeke Klint had just returned from her studies at Aubusson to find herself being asked to take over the leadership role of her own teacher and mentor, Gerda Henning, the country's foremost weaver.

Each of these remarkable women possessed an important sense of vision and idealism tempered with a pragmatic understanding of the situation in which she found herself. Each has had to deal with a degree of deprivation, obscurity, and lack of support and understanding, each has succeeded in realizing her vision and purpose.

It is the example of these women and others like them which has provided the textile arts in the Nordic countries with a solid "home" base in the contemporary world. Each has worked in an important way to bridge the separate realms of traditional weaving and contemporary textile art expression. As artists, teachers and craftmakers, they have provided the present generation of Nordic professionals and amateurs alike with the inspiration and encouragement to continue to develop a thoroughly modern tradition, thoughtfully grafted upon their own rich heritage.

It goes without saying that the textile arts are deeply rooted in the Nordic countries. Still, it is important to restate that simple fact because it explains so much about contemporary textile expression there as well as present attitudes about textiles in general. Scandinavians are thoroughly "at home" with handwoven textiles; they know them, enjoy them, and appreciate them. Most people in the Nordic countries have had some experience with weaving, either in a "slöjd" (crafts) class at school, or more likely, at home. Almost everyone has a mother, a grandmother or aunt who weaves. Or has seen women from the countryside at the town markets with their rugs and table runners for sale in places like Helsinki. And nearly everyone has seen tapestry work in a church, office building, school or recreation center lobby. This spirit of "at homeness" reinforces the strong ties of past to present; it provides continuity and a sense of identity to people's lives and experiences. There is harmony between past and present; neither threatens the other.

Nordic weavers are very much at home with their materials as well. They know linen and wool, have lived with them for centuries, and understand their properties and possibilities. At one time such knowledge was essential for survival – until the 1850s most textiles in Scandinavia were produced at home for immediate use in the family. Today, such knowledge serves to enhance consumer awareness and heighten demand for quality goods. Knowledge of textile traditions has informed contemporary taste, particularly in home furnishings. And the crafts themselves – weaving, spinning, dyeing, and so on – serve as life-enriching activities for amateurs as well as important sources of inspiration for professional artists.

The textile arts have an important place "at home" in the cultural life of the Nordic countries as well. Places of honor are reserved for textiles in a variety of public spaces ranging from offices and government buildings to churches, schools, and even prisons. In such public milieux, textiles allow their viewers to feel more "at home" in otherwise anonymous public spaces.

Artists and public alike in the Nordic countries have been reluctant to embrace the fiber art movement of the past two decades. It is not because they consider themselves immune to influences from abroad, but rather because they have a strong sense of who they are and of the rich cultural heritage they possess. Innovations must become part of that tradition and are absorbed only slowly

and gradually over time. Still, while Scandinavians appear reluctant to take in new impulses without question, they are very much aware of their role in the greater world and of their need to adjust in order to continue to survive and grow. They have learned to make a friend of change, but on their own terms.



The textile arts are indeed alive, well, and strong in the

Nordic countries. A seemingly endless variety of study circles, summer courses, and university and professional training programs ensures the continuity of skills and provides an important outlet for creative involvement at every level of interest and commitment. The work shown in this special issue is just a sample of the fine weaving being done in the Nordic countries today. I hope it will serve as a source of pleasure and inspiration to you in your own creative search.

Välkommen!

This special issue on the Nordic countries is the result of the generosity and cooperation of more than 50 artists from the five countries featured. I would like to thank them as well as the American contributors to this project. Whenever possible I have tried to find writers from each of the countries to submit an article, so that they could speak for themselves and their colleagues. I would especially like to thank Hildur Hákonardóttir (Iceland), Kirsti Rantanen (Finland), Hans Kron Dahl (Sweden) and Sissel Ree Schjønby (Norway) for their incredible generosity and support for this effort. My thanks as well to Hanne Ejsing Jørgensen (Denmark) for her enthusiasm, support, and cooperation in helping me to find many of the wonderful Danish artists featured in these pages. Finally, I would like to extend my thanks and appreciation to Jane Patrick and the staff of *HANDWOVEN* for their tremendous openness and generosity in having me act as "guest editor" for this issue. In view of all the fancy footwork involved in putting together an international project such as this one, Jane and her staff have been ever patient, vigilant, and professional throughout. It has made this project a real pleasure.

Just a final word about terminology. The terms "Scandinavian" and "Nordic" are used interchangeably herein, although the former term strictly speaking refers only to Denmark, Sweden and Norway. Since most North Americans refer to Iceland and Finland as part of Scandinavia, I thought it best to follow that practice, rather than attempt to reform everyone.

Enough words. Now, enjoy the issue! □

Charles Talley, Oakland, California, is guest editor of this special theme issue.

PHOTO: CHARLES TALLEY



FROM HAND TO HAND

Swedish Weaving Today

by Hans Krondahl



MANY WEAVERS and fiber artists in Sweden today have actually grown up in a living tradition of household weaving. In the '30s and '40s, when I was growing up on a small farm in southern Sweden, I watched my mother and grandmother weave rugs and curtains, and occasionally fabrics for clothing. The textiles they made were for immediate use in our everyday environment. Their techniques were neither terribly elaborate nor complicated. Rather, the emphasis was on quality materials used together with quite basic tie-ups and designs.

It has not always been so certain that this tradition of home weaving would endure. During the latter part of the 19th century, domestic weaving was in a serious state of decline. A large number of people gave up home fabric production altogether. Though the introduction of industrially

produced goods was nearly universally welcomed, there was an important group of Swedes who were aware of the danger of losing an important part of their cultural heritage. As a result, the Friends of Textile Art Association (*Handarbetets vänner*) was founded in Stockholm in 1874, followed shortly thereafter by the organization of the national Handicraft Association (*Svenska Hemslöjdsförening*). A group of women, associated with society and court life, began to collect samples of old fabrics, mainly from peasant families, throughout the country. Their efforts grew into a thorough inventory of Swedish traditional weaving, propelling, in turn, an important revival of interest in Swedish textile traditions. The radiation of immense artistic power from both these centers continues to reach aspiring artists and students

alike—whether at the *Konstfackskolan* (Academy of Art) in Stockholm or at the *Konstindustriskolan* (School of Arts and Crafts) in Gothenburg through faculty members who have been trained at one or the other atelier.

The influence of tradition is quite apparent in contemporary Swedish textile art. Rapidly changing international trends have scarcely made an impact upon contemporary Swedish textile art. We have seen very little of the three-dimensional works so widely exhibited and promoted in the United States or at the *Biennale of Tapestry Art* in Lausanne, Switzerland. The reasons for the failure of the "fiber art" movement to take hold in Sweden are complex. For one thing, Swedish artists must be sensi-

A common scene in the Swedish landscape: red houses, white gates and cheerful, inviting gardens.

tive to the tastes of their clients, who have been brought up in an environment which places great emphasis upon quality materials and workmanship. The most important market for textile artists in Sweden is commission work for public buildings. In this sector, experimental work is not encouraged or accepted. What is more important in the Swedish context is that the work be well-executed, durable and colorfast. These elements are the *sine qua non* of all commissioned work.

As a consequence, most textile artwork tends to follow well-trodden paths in format. In that sense, Swedish public works possess an important kinship with Swedish Renaissance and baroque traditions. In the postwar period, textile artists have been working to build bridges between contemporary expressive needs and traditional weaving techniques. The "woven pictures" so prominent in public environments in Sweden today often demonstrate great freedom and skill in blending traditional folk patterns, such as twill, rosepath and monk's belt with flat tapestry techniques.

I am not at all convinced that Sweden's strong textile tradition is such a heavy burden on the backs of Swedish textile artists, though one often hears precisely that. Rather, I think it serves as a fascinating and important resource to me and to my fellow Swedish artists. It helps us to "see" in new ways; suddenly new possibilities come into play. One then has the choice of charting new territory within the framework of traditional techniques. Besides, it feels good to be part of such a great and important tradition, unbroken and continuous from the Middle Ages to the present. One has a sense of joining hands with weavers from the past – from Renaissance Italy to baroque France to ancient China, Egypt and India. And don't forget the Vikings! As a teacher, I feel that I am extending one hand to the past and the other to the future. Serving in this role, teaching younger artists, makes that sense of tradition all the more vital and exciting. □

Hans Krondahl is a textile artist, teacher and textile designer. He's head of the textile department at Konstindustriskolan, Gothenberg, Sweden.



Elisabet Hasselberg-Olsson



"Memory of a Landscape", 5.6×9.6 meters. Cotton warp, linen weft. Woven for Swedish House of Parliament, Stockholm.



"The Rag Rug", linen. Plain weave with bundled yarns.

Elisabet Hasselberg-Olsson creates subtle color shading by using multi-colored bundles of fine weft threads that show through the warp. Through this blending of yarns she creates highly refined lighting effects, giving a sense of mood and atmosphere. The artist shares her studio in Täby, a suburb of Stockholm, with her architect-husband, John. Ms. Olsson's work has been exhibited extensively in Europe.

— Contemporary Textile Art: Scandinavia, Charles S. Talley

PHOTOS: ANDERS QWARNSTROM



"Searching After My Soul", Sandra Ikse, 1985. PHOTO BY THE ARTIST.



"Summer Evening", Maria Hillfon, 1985.

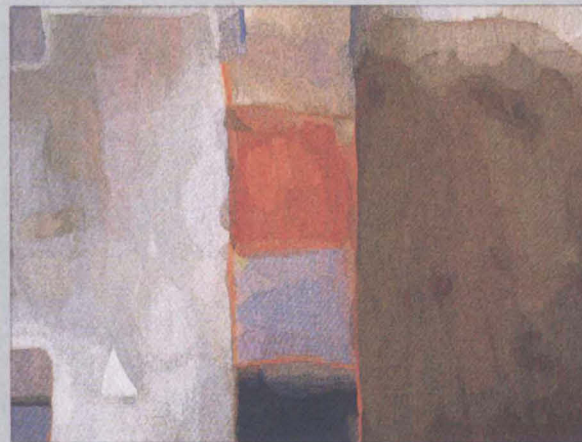

"The Lone Sailor", Ulla Magnusson.
PHOTO: CHRISTER HALLGREN.



"Karen Blixen", Hans Krondahl, 1985

THE centuries-long relative isolation of Scandinavia from the rest of Europe has done much to contribute to an unbroken textile tradition and the dominance of textiles in contemporary daily life. In addition, Scandinavians believe that it is important to enhance daily life with beautiful things. This is apparent in their textiles, as well as in their furniture, architecture and glass design.

Contemporary pictorial weaving in Sweden has its roots in the folk weaving of the Flemish weavers of the 16th century, who were invited to establish an atelier at the royal palace of Gustav Vasa. Of even greater influence was the immigration of itinerant weavers from Flanders to Scania during the 18th century. However, pictorial weaving was not really recognized as an independent medium until the Art Nouveau movement at the beginning of the 20th century. Painters who produced drawings for tapestry realization, such as Carl Larsson and Anders Zorn, were particularly important to the development of pictorial weaving, as was teacher and administrator Edna Martin. Through her work in Sweden's most prestigious arts and crafts schools, she was able to influence the focus of art and textile expression.

Today Swedish textile art enjoys government support through one-percent-for-art legislation and through stipends and commissions paid to artists. But Swedish textile art is also, and perhaps more importantly, supported by an enthusiastic public that places high value, both at home and in public, on the necessity of beautiful and well-crafted textiles.

— *Contemporary Textile Art: Scandinavia*, Charles S. Talley
— *Scandinavian Design*, Eileen Harrison Beer

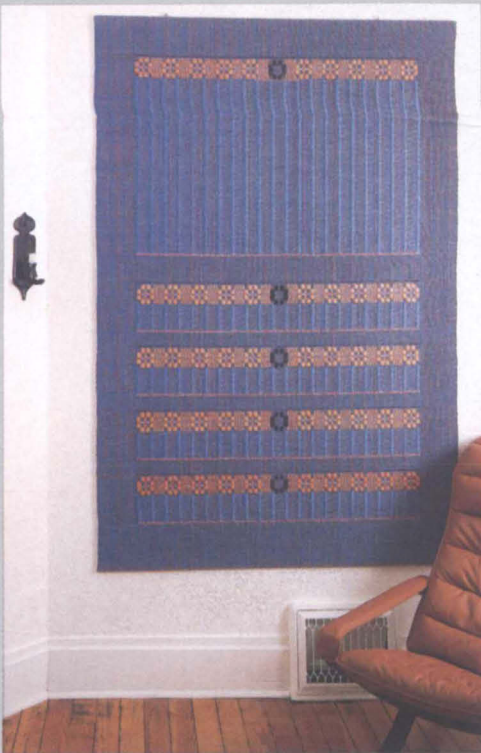

Kerstin Åsling Sundberg

Kerstin Åsling Sundberg uses traditional Scandinavian weaves for her abstract tapestries. Besides the *munkabälte* (monk's belt) shown here, she uses *halvkrabba*, *krabba*, and double weave for designs which bring these historically important weaves into an expressive contemporary genre.

Above: "Blue Chest of Drawers", monk's belt, linen and wool. While appearing very simple, this wall hanging has several design elements which take it out of the ordinary. Notice how the pattern weft stops around the edges to make a border; the yellow pattern bands, made up of several strands of weft threads, gradually shade from dark to light; inlaid "drawer pulls" in a contrasting color lend focal points to the piece. For more about this piece, please see the Instruction Supplement.

Right: Detail of "Harbor Glimmer", monk's belt, linen and wool.

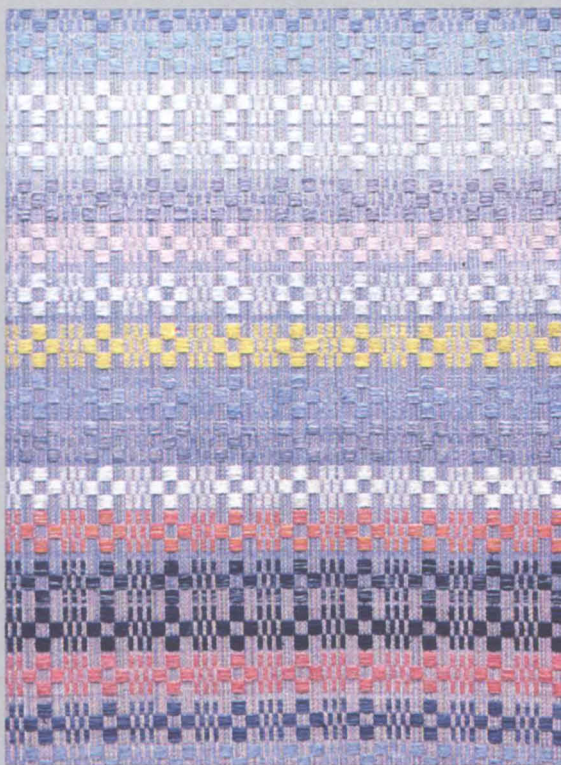

Munkabälte

(monk's belt)

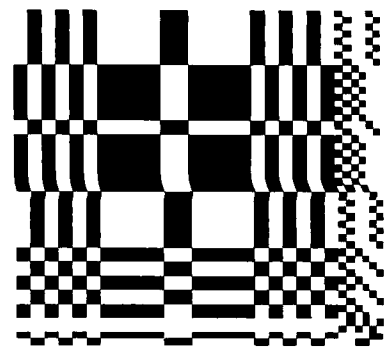

A traditional monk's belt pattern, page 102, *A Handweaver's Pattern Book*, Marguerite Davison. This common four-shaft technique became popular in Scandinavia in the 17th and 18th centuries through patterned fabrics produced by a fledgling home industry and through imported goods as well.

Historically used for coverlets, curtains, table covers and aprons, monk's belt continues to enjoy popularity among today's Scandinavian weavers. Monk's belt can be described as a simplified overshot weave of two blocks (block A threaded on shafts 1 and 2; block B threaded on shafts 3 and 4) woven overshot-fashion with tabby and pattern wefts. The eight-pointed star shown above is one example of this weave.

Monk's belt can be used for narrow borders or bands of pattern on a solid plain weave background, or for all-over patterning. A bright pattern weft, such as red, used on a white background lends a particularly Scandinavian look to a design; an interesting use of color often found in traditional monk's belt places one color on block A and another on block B. As this design by Kerstin Åsling-Sundberg shows monk's belt lends itself well to contemporary interpretation. For more on this weave see *New Key to Weaving* by Mary E. Black, and *A Handweaver's Pattern Book* by Marguerite Davison.

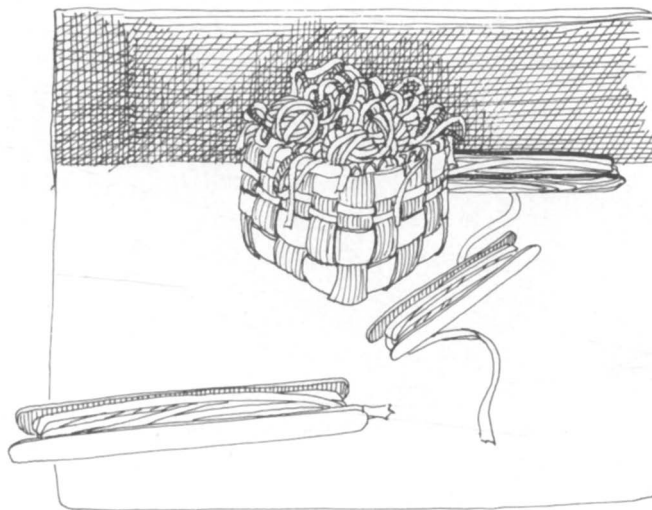

Rag Weaving: a history of necessity

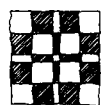

Rags were originally woven not for the floor, but for the bed. In very ancient times, the bed was not a piece of furniture, but a makeshift collection of parts and pieces that were placed here and there as needed. When the bed became a recognizable piece of furniture, either built-in or freestanding, a change in bedding materials also took place. Fur and knotted pile rugs were very early bedding materials; during these early times, bottom sheets of plain woven rags were also thrown down over a bed of straw or hay. (In this cold and damp climate, hay and straw made excellent bedding materials because they could be changed when they became too damp, unlike padded mattresses and ticking.) These heavy and thick rag sheets didn't slip around or allow the bedding material to poke through.

As more rooms were added to homes and as the standard of living improved, the types of textiles associated with the bed became more elegant. In 17th-century upper-class homes, the bedroom doubled as a place to receive guests. It became a showplace and the bedstead became a central element in the display of

wealth and status. Over time, more and more resources and energy were devoted to the home production of elaborate textiles for this showy display, and every bride-to-be spent time in this increasingly important pursuit.

It wasn't until later that rags became common material for rugs, primarily because rugs on the floor were impractical for homes where a single room served many functions.

Before rugs were used, floors were often decorated in other ways for special occasions: straw was spread at Christmas time; chopped spruce was often scattered on Sundays during the winter; sand, often swept into swirling designs, was used during Lent; and at midsummer aspen leaves were strewn. Even in the 16th and 17th centuries, when rugs began to appear on the floors of well-to-do homes, they were often considered extravagant and were used solely for special occasions. Well into the 18th century bare floors were far from unusual in upper-class homes. Rug weaving became more common in the early 19th century, as indicated by personal diary entries stating that rags were being saved for rug weaving. By the middle of that century rugs were finally in common use, mostly due to

improved living conditions and the addition of more rooms to the house.

Some of the earliest rugs used straw and rushes for weft; rags as filler became common in the 1850s as rug weaving gained greater acceptance. Using rags as filler certainly came from a need to economize resources, but the exact origin of rag weaving is not known. Straw may have become less available after the introduction of mechanized threshers. Industry also shifted from the use of linen rags to wood pulp in the making of paper, so households could no longer sell their rags for additional income. Recycling them into weaving became economically sensible.

— *Swedish Handcraft*,
Anna-Maja Nylén

Right: *Rag Table Runner by Inga Krook threaded to a monk's belt variation. The pattern bands are woven in freeform shapes on a plain weave background. 8/2 linen is used for warp; 1/2" and 3/4" fabric strips are used for weft. See the Instruction Supplement for weaving details.*



Reinterpreting old weaves for today and tomorrow

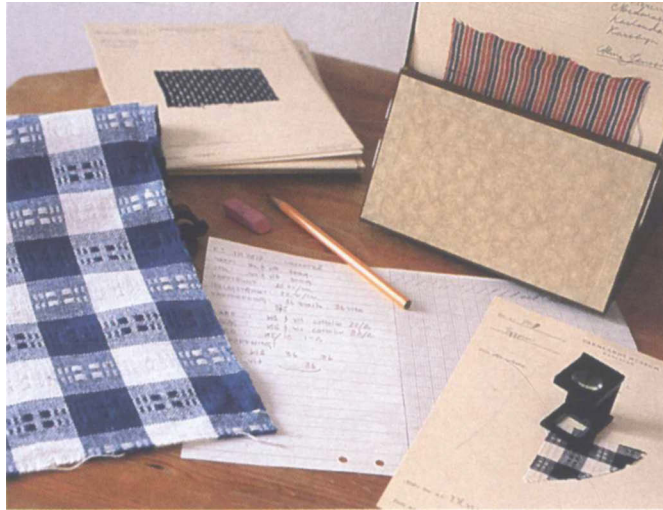

by Margaretha Essen-Hedin



As often as I can take a day off from my weaving, I spend the day at Värmlands Museum in Karlstad. The first time I entered the textile department of this museum I felt like a kid in a toy store. I did not know what to play with first. Finally, I settled on 15 file boxes filled with small pieces of handwoven fabric, the result of somebody's travels around our province in the '20s and '30s to save what could be saved of some of our old weavings. These fabric scraps were glued on file cards which also held information about the fabric and its origin.

So much can be learned from the work in these boxes, and the information fills me with respect for the women of the past who left this impressive heritage. What a great responsibility we have. We need not only to preserve this heritage, but also to increase it at a high rate of interest for the next generation of weavers.

One particularly interesting fabric which I found in these boxes was a monk's belt variation (shown above). Unfortunately, there is no information about how this fabric was used, but I guess that it was a dress fabric. It was woven at 25 threads per centimeter (about 63 e.p.i.) in a fine cotton thread not available today. But if you would like to make a similar dress fabric, I suggest you use 24/2 cotton at 18 ends per centimeter (about 45 e.p.i.).

I often interpret old patterns in other kinds of fabrics by changing their scale and colors, as I've done for the table cloth fabric shown here. The yarn is 22/2 cottolin in blue and white; the sett is about 23 e.p.i. For complete weaving details for my "Heritage Tablecloth", please see the Instruction Supplement.

Margaretha Essen-Hedin is a professional production weaver and teacher. She is a frequent contributor to HANDWOVEN.

A history of table linens

Little information about table customs before the Middle Ages is available. A few tables with painted tops survive from this time. It is believed, though, that during the 1500s damask linen table cloths were imported from Holland and Flanders by the wealthy class; they were used for banquets which demanded a showy display as well as culinary excellence. The napkin is thought to have gotten its start at these great feasts. A special cloth, stretching the length of the table and resting on the feasters' laps, was provided for the wiping of fingers.

During the 17th century, ornate table linens were made in Sweden but used only by the wealthy. It wasn't until the early 1800s that the tablecloth became common in all strata of society. This development corresponded to the wide availability of inexpensive imported cotton. Because cotton thread was readily available less time needed to be devoted to the time-intensive processing of flax into linen that was commonly used for table linens. This freed more time for cloth production, resulting in the use of table linens in everyday life across all strata of society.



Tablecloth interpretation. Please see the Instruction Supplement for Margaretha Essen-Hedin's Heritage Tablecloth. At left: Historical dress from Värmlands Museum, Karlstad, Sweden. PHOTO COURTESY THE AUTHOR.

Upphämta Display Towel

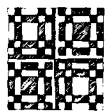
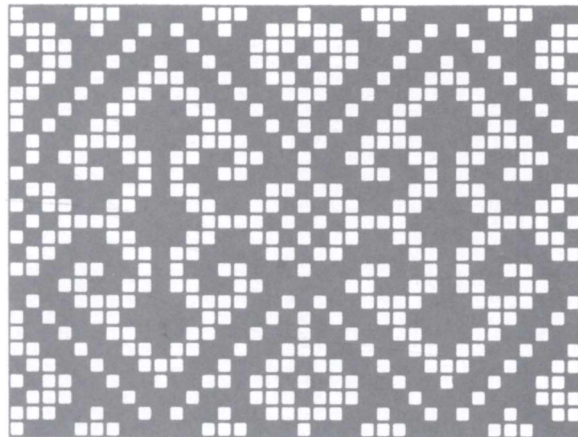

One element that remains from the old-time Swedish custom of "decking out" the home with cornices, hangings and other handwoven finery is the display hand towel. This beautiful length of fabric with rich patterning is hung in today's kitchen to hide the hand towels. The idea of the display towel started when washstands with their bowls and pitchers came into style. This towel is woven in upphämta either on a ten-shaft drawloom or on a regular loom with a weaving sword.

Upphämta is the Swedish term for a weaving system known by many different names. In Sweden it's also called *Smålandsväv*, in Norway it's *Skillbragd*, and in Finland it's *Karelian red picking*.

Upphämta has pattern wefts which float over the face and back of the fabric in blocks. The pattern wefts are not tied down while they are on either surface. Patterns range from simple borders to dense patterns. The motifs are usually geometric: checks, diamonds, stars, crosses, and lozenges combined in great variety.

Upphämta is usually woven with a plain weave ground of linen or cotton and a pattern of wool. The pattern sheds are formed by counting units of the ground weave: each unit contains two, three, or four warps. In the weft, each unit is woven square with two, three, or four ground wefts plus the same number of pattern wefts.

There are several ways to weave upphämta. Working with a weaving

sword gives the most freedom of design. The warp is threaded through long-eyed heddles in units which make the counting easier. For four-end units, the threading is 1, 2, 1, 2, 3, 4, 3, 4. After each tabby row, treadle shafts 1 and 2; count out units and place them on a pick-up stick. Since units from the lower part of the shed as well as the upper are used, treadling must be light. Turn the pick-up stick on edge in front of the reed and transfer the pick-up to a wide weaving sword in back of the heddles. Turn the weaving sword on edge for the pattern weft and then push it flat to the back of the loom while a shot of tabby is treadled. Four pattern shots and four tabbies complete each unit. Remove the weaving sword, make a new pick up and transfer it to the back of the heddles, and the weaving continues.

When a pattern contains several rows which reverse in the middle of the sequence, the pick-up sheds in the first half of the pattern can be saved on rods at the back of the loom as they are woven. To weave the second half in reverse, bring one rod forward to the heddles at a time, transfer the pick up to the weaving sword, and remove the rod.

Some patterns are designed with as few as four pattern sheds, such as *Smålandsväv* patterns. These patterns can be woven with a weaving sword and heddle rods (dowels with string loops holding units or individual warps). See also *Skillbragd*, page 60.

Upphämta can be threaded and treadled, but the loom has to be adapted to this purpose. Drawlooms work well; this display towel was woven on a ten-shaft drawloom. Multi-shaft looms can be adapted by setting up two harnesses (groups of shafts) separated by a short distance and using long-eyed heddles on the shafts closest to the reed. See *Skillbragd*, page 60.

The Instruction Supplement and accompanying articles include specifics about weaving upphämta four different ways: with drawloom, weaving sword, multi-shaft loom, and heddle rods.

Bibliography

- Cyrus-Zetterström, Ulla. *Manual of Swedish Handweaving*. Charles T. Branford Co., 1956.
- Johansson, Lillemor. *Damask and Opphämta*. LTs forlag, Sweden, 1982.
- Keasbey, Doramay. *Pattern Devices for Handweavers*. Doramay Keasbey, 5031 Alta Vista Road, Bethesda, MD 20814, 1981

At right: This Display Towel, designed by Astrid Sonesson and woven by Hanna Johansson, first appeared in *Väv Magasinet, Scandinavian Weaving Magazine*, issue 2-83. It is printed here with permission. Photo: Conny Bernhardsson. Instructions, printed in the *Instruction Supplement*, include directions for ten-shaft drawloom and four-shaft loom with weaving sword. An alternative overshot draft is provided. While our overshot version will produce a similar effect, the design will not be as intricate as the original.





by Charles Talley

SURPRISINGLY, the textile arts in Denmark cannot be typified by the image of the tranquil farmer's wife poised serenely at her loom. Rather, Denmark's history is that of a rich textile tradition which was nearly lost during the Industrial Revolution only to be reclaimed and revitalized in our own century. In this respect Denmark (along with her former colony, Iceland) is unique among the Nordic countries, which otherwise can claim an unbroken tradition in weaving from the Middle Ages to our own era.

Denmark once possessed important traditions in hand-weaving and the other textile arts originating in prehistoric times. Contemporary archaeological excavations attest to the wealth of textile knowledge and connoisseurship which existed long before the Viking and Christian eras. From medieval times until the mid-19th century, textiles served as an important part of home life in a subsistence culture based upon agriculture and fishing.

Unique among the Scandinavian countries, Denmark has always been physically linked to the European continent through its Jutland peninsula. Consequently it has been quicker to receive and respond to impulses from abroad. The Industrial Revolution arrived in Denmark (via Germany) a full quarter century before spreading to the rest of the Scandinavian peninsula. The sudden availability of cheap manufactured goods, both domestically produced and imported, soon eclipsed home and cottage industry products in importance. The Danes adjusted pragmatically to the changing technology, yet remained respectful of handcrafted work. Though functional weaving nearly died out at one point, interest in embroidery continued to thrive under circumstances of greater leisure and affluence.

Faced with the looming extinction of their crafts traditions, the Danes embarked upon a course of considerable

soul-searching. Determined to avoid the worst excesses of the Industrial Revolution, they found direction and inspiration in the writings of William Morris, chief apologist for the English Arts and Crafts movement. Ironically, the rebirth of the textile arts at the turn of the century was to have its impetus among intellectuals in the drawing rooms of Copenhagen's genteel society, rather than among traditional craftsmakers in their cottages.

The revitalization of the crafts—especially the textile arts—was spearheaded by the architects, who from Kaare Klint to Arne Jacobsen have evinced abiding concern for a structure's interior and general ambience as well as for its form. This interest in the everyday, the human, the practical, is emblematic of Danish style. Theirs is a country refreshingly devoid of overbearing monuments to dubious achievements. Instead of exerting their energies to get to the moon, they have embarked on the important journey into "inner space", in order to provide a better quality of life for their fellow citizens.

Within this scheme of "practical idealism" the human being is the scale according to which all achievements must be measured. The home is the center of human activity, and the living room is the heart and hearth of the country as well as of the family. Integrity, simplicity, harmony, order, and solid comfort are the attributes of the Danish home and society as well. No one element should call undue attention to itself in an environment. Rather, every element, from furniture to lighting to textiles, should com-

The harbor is a familiar sight in Denmark where water is so much a part of life.



bine with the others in order to form a pleasing and comfortable whole.

The primacy of the home combined with an abiding sensitivity to human needs has had an important effect on the development of the textile arts in Denmark. The aesthetic agenda of the Arts and Crafts movement combined with the social agenda of the Social Democratic and cooperative movements are both reflected in the establishment of educational structures to foster and renew the textile arts. The National School of Arts and Crafts (now the Skolen for Brugskunst) was founded in Copenhagen in 1927 to train teachers and professional artists and designers. The more populist Danish Handicraft Guild (Haandarbejdets Fremme) was started the following year to encourage amateurs and traditional craftmakers through its study centers, workshops, boutiques and publications established in a national network which remains active today.

Teachers have been instrumental in revitalizing the textile arts and in passing on not only skills and technical information, but also approaches to the creative process itself. Gerda Henning was a pioneer in the field. Her student, Vibeke Klint, has influenced many members of the present generation of both weavers and textile artists through her teaching and artwork. Jette Gemzoe continues that tradition of artist-teacher, while others like Inger Jensen (Pacific Basin Textile Arts, Berkeley) have brought the tradition to North America.

While the schools have kept alive the spirit and skills of weaving and the other textile arts, the architects have continued to have an important influence upon design. Architecture is Denmark's principal aesthetic preoccupation, and the standing joke in the textile community is that every Danish weaver is married to an architect. And indeed, the forms themselves appear to have been "married" to a certain extent. On the whole (though there are important and exciting exceptions), Danish weavers and textile artists share a preference for simple abstract geometric motives. Elegant pattern repeats take precedence over portraiture. The Danish color palette displays a decided predilection for black, white and gray as well as muted pastels.

FOR DANISH WEAVERS and textile artists, the rug is the meeting point of "art" and "craft". They have developed its execution into a vital modern tradition of their own. The well-designed, expertly crafted area rug represents the epitome of good Danish design. It should be sturdy and totally functional, well-constructed with high-quality materials and impeccable craftsmanship. At the same time it should be understated in its elegance, complementing its surroundings rather than calling attention to itself.

In recent decades, the fortunes of weavers and textile artists have paralleled those of the design field as a whole. The postwar boom in Scandinavian design provided an important outlet for the pent-up energies of a generation which endured Nazi occupation. The '60s brought new questioning, challenges, and doubts as to the meaning of success. Artists rejected the puritanical asceticism and supposed anonymity and sterility of contemporary design. The tapestry became a vital form for the expression of personal and social concerns once again. Experimentation

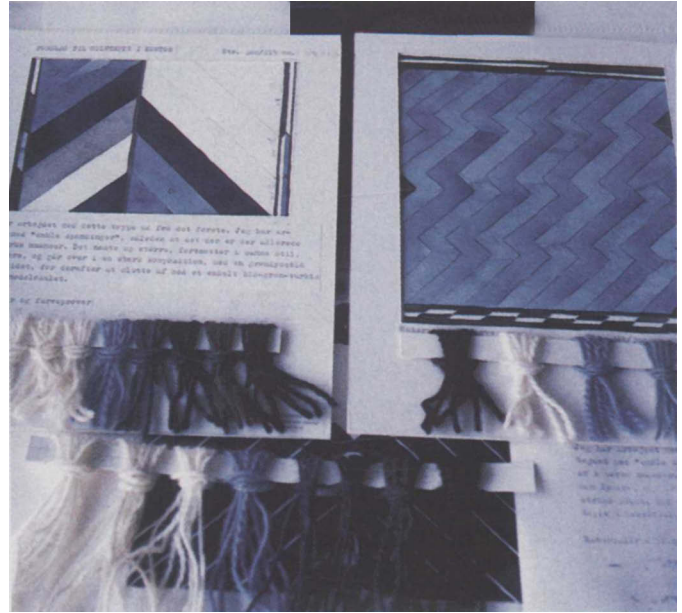

Jette Nevers does painted designboards, which include samples of the intended yarns, before weaving her designs into rugs. This design was a commission for a large office building.

with new materials and techniques reflected the growing influence of work from Eastern Europe.

The '70s brought a period of serious economic retrenchment to Denmark, reflected in the textile arts by an atmosphere of greater introspection and reevaluation. Older structures such as the internationally acclaimed Den Permanente showcase of design in Copenhagen appeared not to meet the needs of younger professionals. Artists and amateurs alike struggled to form new organizations and to explore additional avenues for joint marketing ventures.

The present decade is characterized by renewed vitality and growing sophistication in the textile arts. There is more diversity than ever before in the textile community as professionals branch out with greater confidence into clothing production and fashion design. At the same time, artists are exploring such realms as papermaking — unheard of in Denmark until recent years. Growing economic pressures have made artists aware of the need to market their work more effectively. The recently opened Danish Handicraft (Dansk Kunsthandverk) center along Copenhagen's fashionable Strøget, represents an impressive effort by DKL, the Danish association of professional craftmakers, to reach a sophisticated domestic and tourist market.

All of the textile arts are alive and well in Denmark today. Organization building, public education, and marketing efforts are providing a solid base for the textile arts in the present generation of Danes.

The Danes have a true talent for making friends with change, for being able to be open to and to select from a wide variety of influences from abroad without losing a sense of themselves in the process. They are eminently practical about preserving what is important to the spirit of tradition without slavishly imitating the forms of the past. They are very much "at home" with the times, and with themselves. □



Top: Rug in tapestry technique, Jetta Gemzøe. PHOTO BY PER DREYER.

Left: 12-shaft double weave, Anne Birgitte Hansen. PHOTO BY THE ARTIST.

Above: "Blå Maske", Anne Bjørn; tapestry. PHOTO BY GURLI NIELSEN.

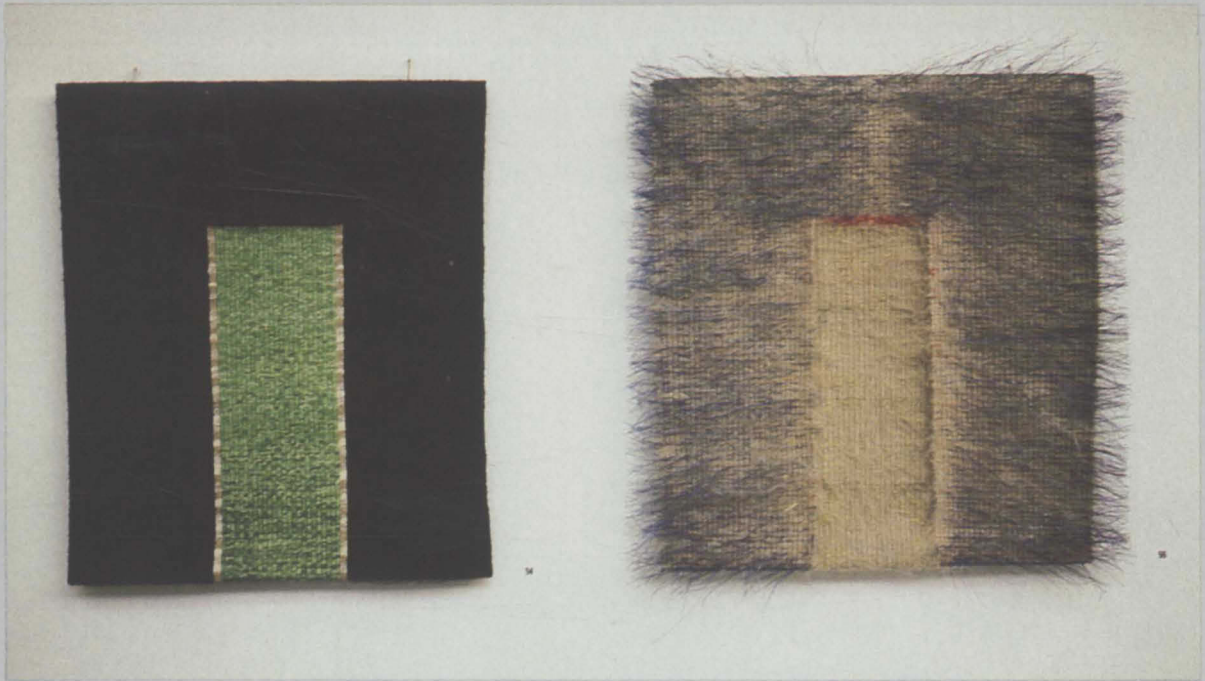

Top: "The Gate of Spring and The Gate of Fall", Anne Marie Egemose; mixed media. PHOTO BY THE ARTIST.

Right: Handwoven bag and belt made from Polyetylen and PVC tube, Annette Juel. PHOTO: FARVELABORATORIET.

Above: "Pigs On a Picnic", Margrethe Agger; tapestry. PHOTO BY THE ARTIST.

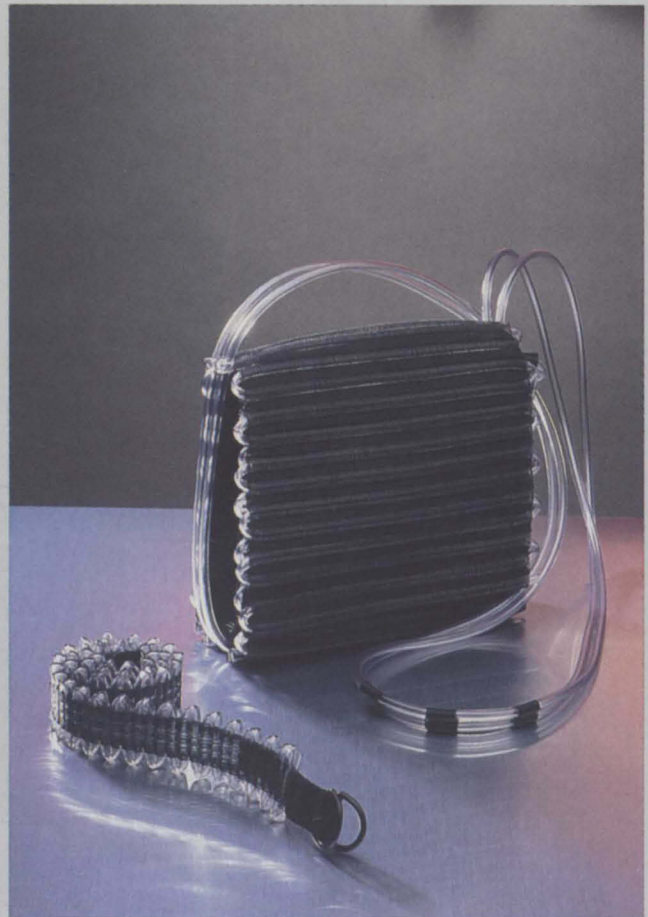

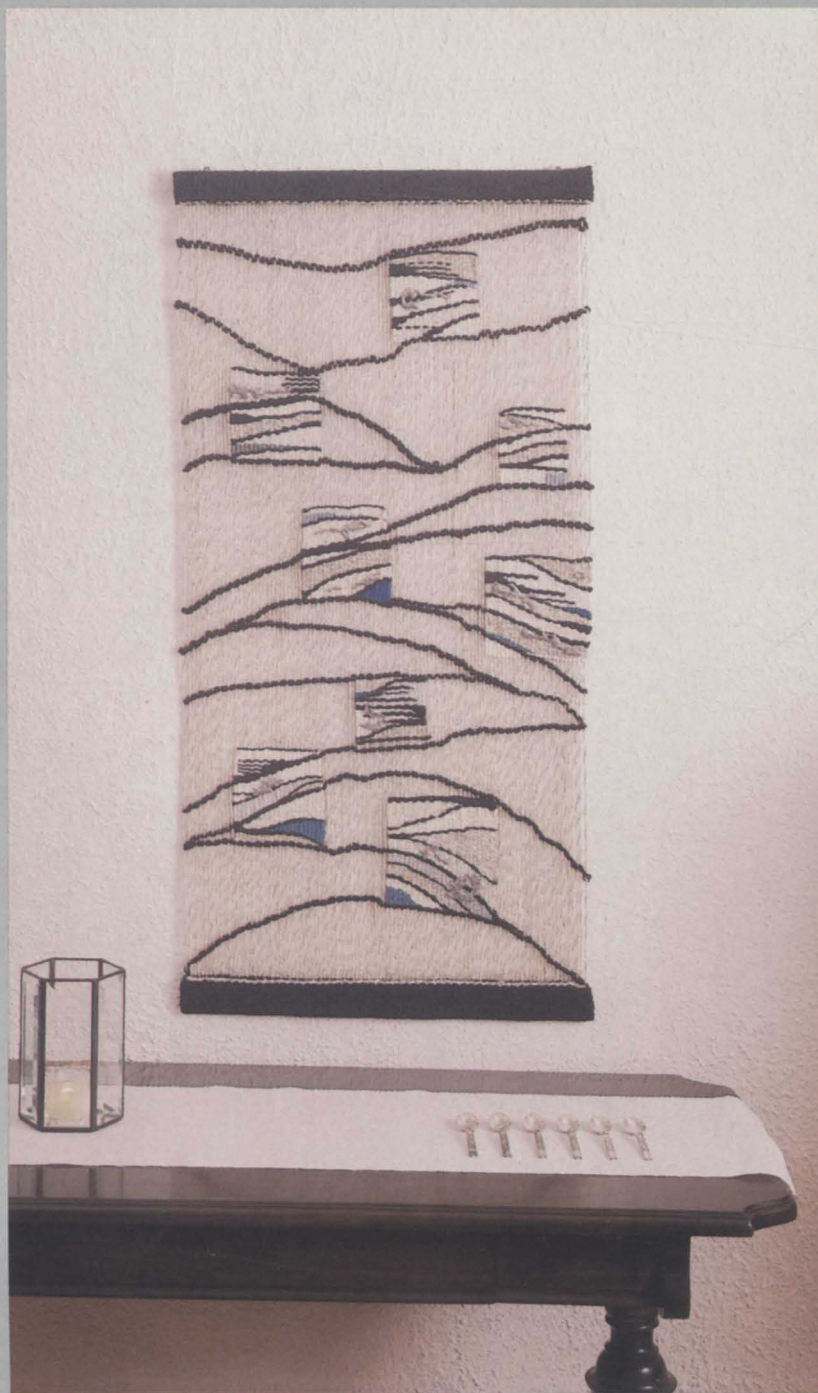

Tin and Thread Tapestry Hanging

designed by Elisabeth LaCour

One can sense that the rolling hills of a stark winter landscape in Denmark could have inspired this unusual piece that combines unweaved warps, areas of tapestry, and hardened tin. The surprise element which is particularly delightful in this hanging's design is the use of gracefully curving black lines to "tie together" the unweaved warps and the tapestry squares. For more on this Tin and Thread Tapestry Hanging, please see the Instruction Supplement.



Inspired Bedspread

CONTEMPORARY DANISH WEAVING



PHOTO: OLE WOLDBYE SETTING: THE ALTERNATIVE SLEEP CENTER, BOULDER, COLORADO

AN OLD textile became the impetus for this Inspired Bedspread. Milk garlands, now a thing of the past, were once worn on top of milkmaids' heads as cushions for their milk pails. Today they are reminders of a past life and evidence of a need to economize resources to the extent that even little bits of fabrics could not be wasted. This garland also shows, through its lively crazy-quilt-like piece work, the desire to make daily life a little more pleasurable.

This project, woven by Anne-Mette Holm, was part of a recent exhibit of this weaver's work at the Kalundborg and Omegns Museum in Kalundborg, Denmark. The bedspread is a weft-faced plain weave in a fine 6/1 wool. While the overall design evokes a sense of simplicity, the weaving itself is quite challenging: the sett is 22 e.p.i.; the p.p.i. is 60. The result, however, is well worth the effort: the fabric excels in drape and sturdiness and in the beauty of its handsome, weft-faced stripes in carefully planned colors. For further details on the Inspired Bedspread, please see the Instruction Supplement.



Form Follows Function

THE SCANDINAVIANS have a word for the harmonious marriage of functionalism and art. They call it *brukskunst*, which literally means “useful art”. This concept demands that a design be not only appropriate for its intended use, but that it also be a beautiful object. Interestingly, Scandinavians do not struggle over defining what is craft and what is art, often the subject of discussion in the U.S. In the Scandinavian view, both craft and art are required to produce *brukskunst*.

The projects on these two pages illustrate the integration of design and function. The rug (or wall hanging) above is a powerful, beautiful piece of

work. It also meets all the criteria for a good rug: it lies flat on the floor, it has an appropriate sett and weft density to make a firm fabric, its end finish protects the weft and produces a tidy edge. The tapestry join chosen works well to produce the desired design; it also doesn't leave lumps where colors meet which would be prone to additional wear. This Black and White Rug was designed by Jette Kai; for more details about this rug please see the Instruction Supplement.

The black and white plaid shawl, opposite, is another study in clean, crisp design with a functional purpose. The color scheme is simple but striking—a surprising turn on the

design is the reversal of the colors at the halfway point to produce a design that's predominately white on one end and black on the other. Worn over one shoulder, as we've shown here, it makes a dramatic addition to a simple black dress. Woven by Kim Naver. Further details about this Black and White Shawl are in the Instruction Supplement.

—*Scandinavian Design*,
Eileen Harrison Beer

Above: Black and White Rug by Jette Kai; opposite, Black and White Shawl by Kim Naver. For further details on these two projects, please see the Instruction Supplement. SETTING: THE DANISH DESIGN CENTER, BOULDER, COLORADO.





PHOTO: CHARLES S. TALLEY

A Living Tradition

by Lila Nelson



RURAL NORWAY has an ongoing tradition in weaving that has been documented to some degree since the 1600s. American artists tend to respect the quality of that tradition and envy the foundation it provides. Norwegian weavers have viewed it with mixed emotions, however, ranging from a high regard through indifference to downright hostility. A fiber artist from Sogn teaching several years ago at the Norwegian-American Museum in Decorah, Iowa, had to be vigorously persuaded to discuss the designs and colors in early *krokbragd* (bound weave) from her home region. She saw the past as a stumbling block rather than a foundation to the creative development of her mother and to artists of her mother's generation. Other Norwegian weavers take pride in precise thread-by-thread reproductions of the old. Between these extremes lies a wide range of attitudes. The important point is that the tradition is there, visible and inescapable, and every Norwegian artist-craftsman must come to terms with it in his or her own way.

Two qualities characterize that tradition: distinctiveness from weaving on the continent and in other Nordic countries, and diversity within geographic areas of Norway itself. An example of the former is the picture weaving which flourished primarily in the valley of Gudbrandsdal from the early 17th into the 18th centuries. Its origins remain obscure, though many scholars believe it began with tapestry weavers from the Lowland countries on the continent who, in the political upheaval of the early 1600s,

may have followed the so-called "royal route" existing north out of Oslo until they found an area receptive to their work. Whatever its beginnings, in Gudbrandsdal picture weaving became something different. With its flat-planed lack of perspective, limited color palette, profusion of decorative detail, and non-realistic treatment of subject matter as well as in its joining and outlining techniques, it was quite unlike the painterly productions from the continent. A similar individuality reveals itself in the three-shaft *krokbragd* (bound weave) popular all over Norway, particularly in the 18th and 19th centuries, but little known even in the other Nordic countries, where bound weave generally appeared on a four-shaft rosepath threading.

Within the broad confines of traditional Norwegian weaving, an amazing diversity existed among the various geographic areas. That most basic of objects, the *åklæ* done in *rutevev* (coverlet/wall hanging done in geometric designs in an interlocking technique) began in Sogn with eight-petal flower motifs within octagonal frames in red, gold, brown and natural; but it very shortly appeared south along the western coast and inland in a variety of designs and colors. Hardanger turned the bold flowers into smaller eight-pointed stars alternating diagonally with diamonds and crosses and added blue to the color palette. Rogaland added borders on all four sides with diamond forms which gave an Indianesque look, inviting comparison with Navajo designs; and Nord Hordaland turned out horizontal bands of overshot weaving alternating with the



geometric tapestry forms. There was also a variety of techniques; while single interlock tapestry appeared most often, some designs were always executed in double interlock, and a few examples of shared warps have also been discovered.

In some areas, coverlets in supplementary weft techniques were most in evidence. Telemark produced a five-or six-shaft overshot pattern with a lemon shape which gradually appeared in variations in other parts of the country. An inlay weave which seems to have sprung up in the 1700s in a section of Vestfold has highly stylized urns and flowers on horizontal plain weave bands in which various shades of yellow are prominent. Nothing quite like them shows up anywhere else in Norway. In Sor-Trondelag and Gudbrandsdal a tradition in double weave pick-up developed, continuing to flourish in the former while Gudbrandsdal turned its interest to the picture weaving mentioned previously. Krokbragd enjoyed favor throughout the country, but in Vest Agder it was sometimes embellished with a thin overlay of large geometric forms in rya knots or was alternated with *tavlebragd* (monk's belt) in horizontal bands. Sometimes bands of one color were treadled in bound weave while geometric designs were picked up, producing a variant called *dansk bragd*.

NORWAY'S POLITICAL history and its geography influenced the character of its folk weaving tradition. Exposure to world trade centers during the Viking period and to the artisans of the Roman empire after the Christianizing of the country around A.D. 1000 introduced a breadth and vitality to the cultural life of the rural landholders of Norway as well as to the urban populace. Feelings of political and cultural pride developed through the prosperous and unifying 1200s, but calamity in the form of the Black Death struck in the mid-1300s. Over a third of the population died. The farms could no longer produce sufficient food, and world trade declined. Political vulnerability resulted in complete domination by Denmark by the year 1400, and Norway was not to regain full independence for 400 years.

These events were catastrophic to the country as a whole but were most damaging to the professions and the urban culture. The landed gentry tended to retreat into their mountain or valley strongholds and subsist on what they themselves could produce. Separated by fjords reaching deep into the country or by impassable peaks and glaciers, geographic units became culturally distinct, developing their own styles of dress, foods, dances, architecture, and even language. A gradual improvement in rural living in the 1700s—the introduction of glass for windows and chimneys for fire control were especially important—and a slowly developing prosperity added to the vigor of these emerging societies.

An increasing awareness of the industrial and urban in the 19th century eroded the strength of rural traditions. An influx of youth to the cities weakened established family ties and patterns of culture centering around those ties. As home-produced objects were perceived as inferior to the manufactured, the skills needed to provide these objects were

forgotten and all but lost. However, even as these attitudes grew, conscious forces were at work to counteract them and to preserve the heritage of the past. Political events aided these forces as Norway moved from domination by Denmark and later Sweden to final complete independence in 1905. The establishment of outdoor museums which brought together buildings and interior furnishings used by the rural people was an important, and a uniquely Scandinavian, insurance that the early culture of the common man would not be forgotten.



Norwegian teacher Elsa Bjerck demonstrates weaving of a wide belt at the Norwegian-American Museum in Decatur, Iowa.
PHOTO: LILA NELSON

Some attempts to revive old customs revealed romantic and less-than-realistic conceptions of the past together with a desire to rigidify them. Nowhere does this show up more than in modern versions of the traditional *bunad* or folk costume for festive occasions. Examples in museums and private collections as well as depictions in art and photography show vitality and change in these costumes throughout the history of their use in rural Norway; but the recent tendency has been to arrive at one prescribed outfit which becomes *the correct bunad* for a region and one from which there is no acceptable deviation. Recent studies by costume experts such as Aagot Noss of the Norwegian Folk Museum and efforts by the National Organization for the Preservation of Costumes are doing much to develop an awareness of the rich variety of dress both within and among the various regions.

A constantly developing professionalism among the district museums of Norway is helping greatly to preserve and disseminate knowledge and appreciation of material culture. At Voss, to cite only one example, a fully furnished early farmstead stands on its original location while across the road is a modern climate-controlled adjunct complete with excellent storage, conservation, interpretive, and exhibition areas. Historians are using museum collections for much needed research into textiles. Marit Wang's recent analysis of technical and stylistic elements in the *rutevev* at the historical museum in Bergen is a case in point.

Through that nationwide craft organization called Husflid, familiar to most tourists for the "Husflid store" in practically every Norwegian town, education in the folk arts is provided along with an outlet for sales. *Husflidskoler* in



many areas provide courses in the fundamentals of weaving and other textile arts lasting one or two years; the schools are excellently equipped and staffed. Students learn basic traditional skills and also develop contemporary patterns from old techniques. Though Husflid's reputation as a protector of tradition has risen and fallen through a somewhat checkered history, it appears at present to be accomplishing a good deal.

NORWEGIAN immigrants to America put aside their rosemaling brushes, carving tools, and looms to build farms and communities when they first arrived in the New World. By the latter half of the 19th century, when Norwegian immigration was approaching its zenith, the railroad had reached into western areas of settlement, bringing with it manufactured cottons and other cloth which made weaving unnecessary. However, events such as the 1925 centennial celebration of Norwegian independence from Denmark rekindled, in the midwest United States particularly, an appreciation for the heritage left behind. Knut Gjerset, then director of the Norwegian-American Museum, organized a monumental craft exhibition in Minneapolis, photographs of which show walls lined with coverlets in traditional *rutevev*. Women resurrected their *bunads* and wore them in parade down the flag-lined route through the center of that city. During this period Pauline Fjelde travelled from her Minneapolis home back to Norway where she studied tapestry techniques, thus fulfilling her ambition to depict American Indian legends in picture weaving. The result is "Hiawatha Returning From His First Hunt", a monumental work of major importance in the history of weaving among Norwegian-

Americans. Today other Americans have followed her example, studying in the Husflid schools in programs adapted to their needs or, if they are proficient in the Norwegian language, signing up for standard courses of study.

The Norwegian-American Museum is attempting to carry on the work begun by Knut Gjerset through weaving classes by teachers from Norway and by workshops held in various regions of Norway. Though the intention has been to perpetuate and preserve Norwegian textile traditions in America, we find that American traditions are also being introduced to Norway. In a 1982 workshop organized by the Museum in Valdres to study the traditions of that area and taught by Marit Anny Tvenge, I was puzzled to find on one of the looms a familiar overshot pattern from Marguerite Davison's *A Handweaver's Pattern Book* identified as Mary Ann Ostrander Pattern. I knew that Marit Anny discovered that pattern only several years earlier when she had seen and admired it on a blouse by Decorah weaver Betty Nelson, and that she had subsequently made a tablecloth in it. The explanation came after our group was invited to a yearly event at Kvamshall, the community center where people congregated to review the year, share their talents, and partake of marvelous food. The walls of the spacious building were literally covered by weavings of people in the community, and apparent among them was the Mary Ann Ostrander overshot. Marit Anny had introduced "The Decorah Tablecloth" pattern, the name by which it became known in Valdres, and it had found favor. She had therefore included it in our workshop because it was indeed a part of that living Valdres tradition, as well as an example of what "living" tradition means. □

Lila Nelson is the curator of the Vesterheim Museum in Decatur, Iowa.

CONTEMPORARY NORWEGIAN WEAVING



Left: "Lake", Per Göransson and Eli-Marie Johnsen; tapestry. PHOTO BY THE ARTISTS.

Far left: "The Cherryblossom Garden II", Brit Fugleavaag; tapestry, rya and windings. PHOTO BY O. VOERING.

CONTEMPORARY NORWEGIAN WEAVING



Above left: "Love Letter", Ellen Lenvik; tapestry and rya technique.

Above: "Wandering", Carin Wessel; ikat and tapestry.

Left: "Tapestry", Sissel Blystad; Tapestry woven in six separate sections.

ALL PHOTOS BY O. VOERING

Rose Jacket in Twill

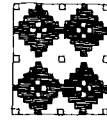

As weavers we are quite aware of the usefulness of the twill weave structure. It is more flexible than plain weave, weaves up into a denser fabric, and can be woven on a four-shaft loom. Not surprisingly, early Scandinavian weavers found twills desirable for all kinds of garment and furnishing fabrics, from trousers to curtains to towelling.

The evidence of three-shaft twills in Scandinavia appears very early, in the 7th century. These fabrics were probably woven on a warp-weighted loom, or perhaps, as Margrethe Hald suggests, on a two-beam vertical loom. The proliferation of twills, though, seems tied to the development of the horizontal loom. This harness loom made it more efficient to weave twills, and was common in the 13th century and well established by the 14th century.

Until more recently, plain weave and simple four- and eight-shaft twill fabrics were woven at home, while twill variations such as damask and dräll, which require more complicated looms, were more often purchased.

— Swedish Handcraft,
Anna-Maja Nýlen

As Blake draws on the versatile twill for her Rose Jacket, which combines two four-shaft twills in the warp threading. This fabric requires eight shafts, but a similar fabric can be woven on four shafts with a slight variation in the pattern. We've provided drafts for both versions of the Rose Jacket in the Instruction Supplement.

Traditional Dukagång For Contemporary Textiles



Dukagång is the Swedish name for one of a group of colorful, patterned inlays woven with butterflies on a plain weave ground. These inlays are worked face down so the turns at the ends of the pattern weft rows don't show on the face. In *dukagång* the inlays are tied down by every fourth warp, and because the same tie-downs are used throughout the piece, a striped effect is created giving rise to the name *dukagång* or "cloth paths". It's also called "floating in stripes". The other inlay techniques include *krabbasnår* (floating in a diagonal pattern) and *halvkrabba* (floating in squares). Often, these techniques are used in the same piece.

For *dukagång*, the loom is threaded 1, 2, 3, 4. *Dukagång* is woven face down so that the pattern shed raises three shafts, for instance 1, 2, and 3. This is the only pattern shed for the piece. A butterfly is made for each color area across the width and placed as desired in the pattern shed. After the pattern shed, the butterflies rest on the surface of the fabric while one or two rows of tabby are woven. The pattern row is repeated as many times as it takes to square the weave (usually three or four) before a new pattern row is worked. Color areas adjacent to each other can be interlocked; be careful to position the interlock so it's inconspicuous.

For further discussion of *dukagång* and related inlays, see Ulla Cyrus-Zetterström's *Manual of Swedish Handweaving*.



This Lenten Pulpit Antependium, designed by Mary Temple for the Shepherd of the Valley Lutheran Church in Lakeland, Minnesota, is woven in half-dukagång, where the dukagång is worked on a plain weave background. In full dukagång the background is also covered. For more on this Antependium please see the Instruction Supplement.



Rugs In the Scandinavian Way



The rich patterning of multi-colored twill rugs often comes to mind when we think of Scandinavian weaving. We most commonly see four-shaft rosepath threadings in Sweden and we associate three-shaft krokbragd with Norway, but both four-shaft and three-shaft twill boundweave rugs were woven in both countries. These structures are well suited to producing sturdy rugs which are also highly decorative. The weaving technique is the same for both rosepath and krokbragd; the number of shafts used distinguishes them from each other.

Krokbragd

Like rosepath woven in boundweave, krokbragd is a weft-faced weave. There are several threading variations, but the simplest is a four-thread repeat: 1, 2, 3, 2 (see draft). The right side of the rug looks like a plain weave fabric, but the back side has three-thread floats. The treadling remains constant (1-2, 2-3, 1-3). One row of pattern requires one pick in each of these sheds. The three picks pack in together and appear on the rug's surface as a single row. A solid line of color will result from the use of a single color in all three sheds; patterns are produced by using two or three colors. The overall effect develops through variations in the

number of colors and in the color sequence. Warp sett is critical for this multi-weft weave: if it is too close, the weft won't pack in adequately, and if it is too loose the rug will be flimsy.

Rosepath

Rosepath uses four, instead of three, shafts. There are numerous twill threadings, which could be used; the one here is quite traditional. This is a 3/1 twill, which means that three shafts are lifted at a time. Four weft picks produce one row of the pattern. As with krokbragd, managing the wefts and making tidy selvages can be challenging. Floating selvages are invaluable for straight, even selvages.

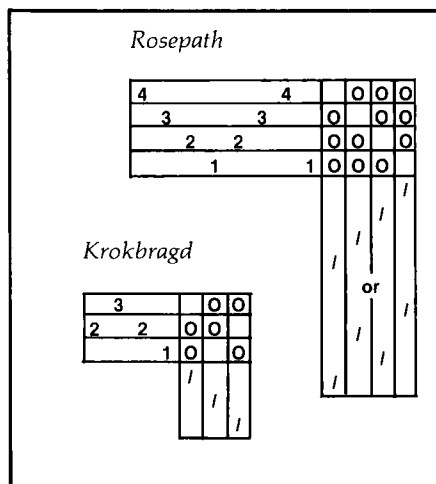

Some hints:

- Use a pair of floating selvages at each side, weighted separately.
- Use very tight tension on the warp with about 12-oz weights on the floating selvages.
- When throwing a pick of weft, bubble it into a single arc about 6" from the fell at its center, to minimize draw-in.
- Bring only the color that shows on shaft 1 to the selvedge; drop all the others behind the web and, if necessary, wrap the shaft-1 color around the floating selvedge to compensate for the absent wefts.
- When an area is weaving with only one or two colors, a short-cut treadling can be used in rosepath. This saves time and yarn and evens out the tension differences on the face and back of the rug. For more on this treadling method, see the Instruction Supplement.

Watching the pattern develop makes for enjoyable weaving on both the three- and four-shaft techniques. Designing your own patterns on graph paper is another pleasure worth exploring. For more on rosepath and krokbragd see these sources: *Handwoven*, March 1981, "Krokbragd" by Sharon D. Alderman; *The Manual of Swedish Handweaving* by Ulla Cyrus-Zetterström; and *The Techniques of Rug Weaving* by Peter Collingwood. □



*Bound Rosepath Rug by Phyllis Waggoner. Please see the weaving details for this piece in the Instruction Supplement.
At left: Traditional krokbragd coverlet on display in the Vest Agder Museum at Kristiansand, Norway. PHOTO: LILA NELSON.*

Skillbragd

A Decorative Pattern Weave

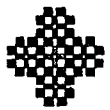

Elegantly rustic is this Norwegian-inspired runner with its densely decorated surface of repeating vertical pattern bands. It's woven in a variation of *upphämta* called *skillbragd* in Norway. In Sweden this variation is called *smålandsväv* or "threaded *upphämta*" because it's threaded and treadled rather than being picked up (see *Upphämta*, page 42). It has been used extensively for coverlets throughout Scandinavia.

Skillbragd or *smålandsväv* is traditionally woven on a counter-balanced loom with two harnesses (groups of shafts). The *pattern harness* consists of four shafts of long-eyed heddles placed just behind the reed. About 8"-10" further back is the *ground harness*, which consists of two or four shafts with regular-eyed heddles. The distance between the harnesses is needed for the sheds to operate well.

The warp is threaded through the ground shafts in plain weave; then it's gathered in units of four and threaded through all, some, or none of the pattern shafts according to the draft. The long eyes of the pattern-shaft heddles allow the plain weave shed to be formed within them.

In weaving, each pattern pick is followed by a tabby pick of finer thread, using the tabby sheds alter-

nately as in traditional overshot. Two pattern picks and two tabby picks square a unit. The pattern weft usually does not go all the way to the selvedge, and the fabric is woven face down so that the weft turns are on the upper side of the web.

Myrna Golay has adapted this method of weaving *skillbragd* to a ten- or twelve-shaft counter-march loom with string heddles. Instead of placing long-eyed heddles on the pattern shafts, she threads the units in the space *above* the eye of a regular string heddle. She uses six shafts, four at the front and two at the back, skipping the shafts in the middle to give the necessary distance.

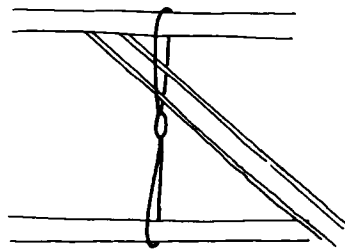

This runner also can be woven on a regular loom by using heddle rods (dowels with string loops around groups of warps). The Scandinavian way is to use long-eyed heddles on the shafts, threading them in plain weave. In back of the shafts, the pattern units indicated in the draft are

picked up and placed in string loops on a heddle rod. For this pattern, four heddle rods are needed. After each tabby is woven, a heddle rod is lifted and the pattern weft is woven in the resulting shed.

Here's another method you might like to try on a jack loom with regular-eyed heddles. Remove the front shafts from the loom, leaving two shafts at the back. Thread the loom in plain weave (if the warp sett is dense, four shafts might have to be used to get a shed easily). In front of the shafts (where the missing shafts used to be), pick up the pattern units indicated in the draft and place them in string loops held by a dowel; you'll need four dowels for this pattern. After each tabby row, lift a dowel and throw a pattern weft in the shed formed. Two tabbies and two pattern wefts square each unit. □

Above: Detail of traditional *skillbragd* or *smålandsväv* in linen and wool. Courtesy Astri Gauffin Feist. PHOTO: CHARLES TALLEY.

At right: *Skillbragd Runner* by Myrna Golay. Instructions for this piece requiring ten shafts are in the *Instruction Supplement*. We've also included a six-shaft, warp-patterned variation which differs somewhat from the original. You can also weave this piece on a four-shaft loom with pattern dowels as discussed above.

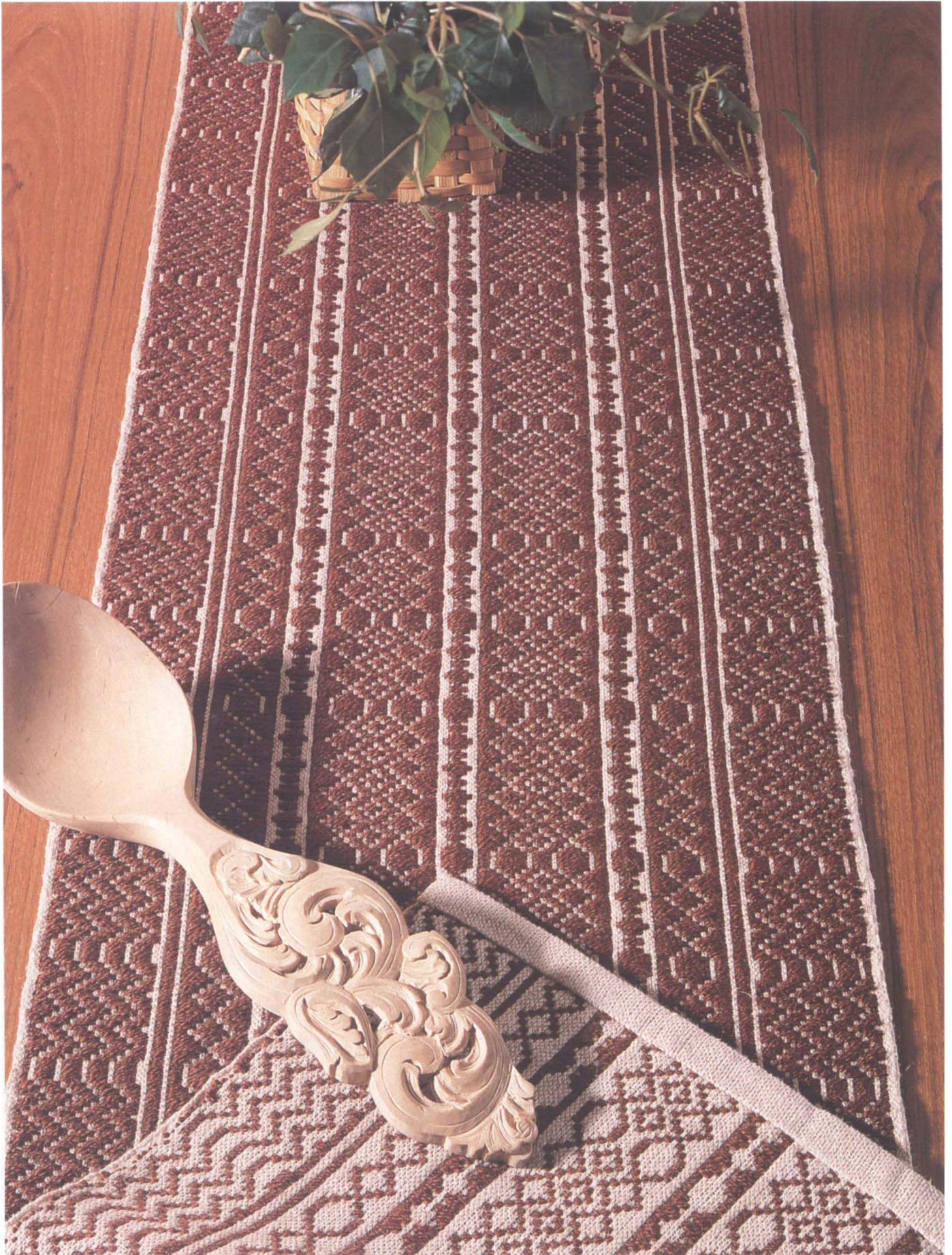

SETTING COURTESY DANISH DESIGN CENTER, BOULDER, COLORADO

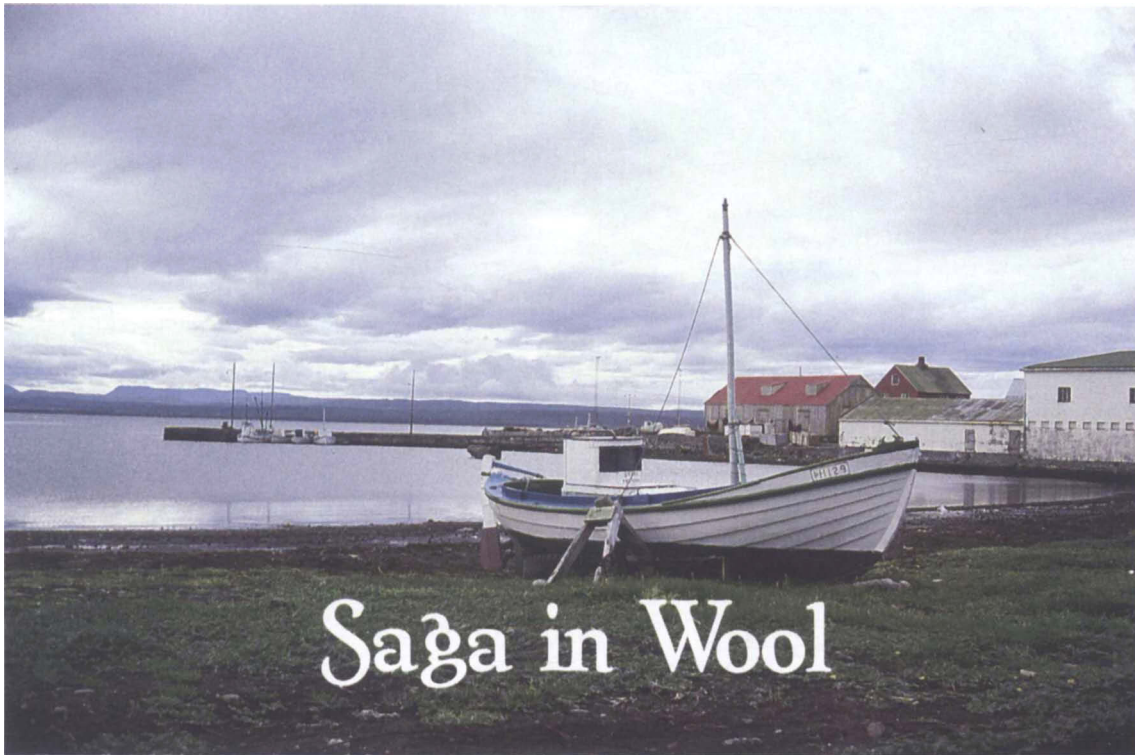

PHOTO: JANE PATRICK

Saga in Wool

by Hildur Hákonardóttir



AN OLDER FRIEND remarked to me in a conversation recently that “it feels so good when I am working with wool. It feels like it is in the blood somehow. My mother taught me all the techniques she knew, even though I think she was aware that the times were changing and that I might never have use for them.” Indeed, weaving was once so completely integrated into Icelandic culture that even today many common sayings derive from textile colloquialisms. At one point in our history, woven goods were our primary export commodity; the monetary system was even based in part upon the value of a fixed measure of woven twill. Still, it is interesting to note that contemporary textile art expression in Iceland has developed quite independently, without particular reference to this rich textile tradition. In fact, our pictorial heritage in cloth – altar frontals and coverlets that depict both hallowed saints and gallant knights, both the Virgin Mary and fantastic demons from the netherworld – has for the most part involved embroidered forms rather than woven ones.

The present generation of Icelanders is the very first one in our long history that has not learned to spin yarn or to weave. The weaving of cloth has been a time-honored cottage industry, a tradition that once involved nearly every farm family. In fact, during the Middle Ages, Iceland exported woven goods to Norway and the rest of Scandinavia – countries which shared our climate and geographical situation. Our looms were in constant use then, producing woven goods that could be traded for corn and timber, wax and tar, or metals and other luxury items from abroad. The traditional Icelandic loom was of the upright,

warp-weighted variety. When the horizontal loom, patterned after the Oriental draw loom, reached Europe during the 12th century, it took a full 500 years for the “new” technology to reach this westernmost outpost of European culture! Over time, Icelanders were no longer able to compete with the efficiency of the new weaving technology and so turned to knitting instead. For a period of more than 200 years it could be said that every woman and child (and not a few men, besides) spent their precious free time knitting socks and mittens for export. Weaving, however, was still significant for the domestic market, though most of the cloth was quite plain and either dyed or felted as it came off the loom.

At the start of the 19th century, definite steps were taken to modernize the wool industry in Iceland. The more prosperous farmers could travel abroad to see how horizontal looms functioned. Both the spinning wheel and the water-powered carding machine were introduced into this northern clime. But these piecemeal innovations came too late. The Industrial Revolution already underway in Europe would soon render the handloom obsolete for commercial purposes.

Traditionally, weaving on the warp-weighted loom had been a woman’s job, but with the importation of horizontal looms, the men took over and subsequently dominated the field for more than a century. In time, though, it became clear that there was no hope of establishing a textile indus-

Fishing is the main industry of this island country in the North Atlantic. This photo of the Ólafsfjörður harbor is a typical scene.



try for anything beyond the home market. And even that market was being challenged by the growing importation of goods of superior quality and lower price than domestically produced goods. Once the loom was deemed no longer practical, the men handed it back to the women. Freed from the traditional task of producing utilitarian goods, women were then able to explore the creative dimensions of weaving as a means of artistic self-expression.

What holds true for the Icelandic experience would appear to be valid for other cultures as well. If a country has a well-established tradition of tapestry weaving, the tradition is more closely allied with other forms of artistic expression than it is with the production of utilitarian goods dictated by the demands of modesty and the cold. Indeed, much of what is being produced on the loom in Iceland and elsewhere today is closer to other contemporary artistic forms and concerns than it is to the weaving tradition *per se*. Often as not, textile art has tended to “slide” off the loom in recent years and involve itself with either other thread techniques or else with individual observations and experiments with thread-like materials.

In the case of Iceland, certain rather exceptional cultural conditions have given us a predisposition to work with wool. Indeed, it *is* in our blood, in a manner of speaking. Contemporary Icelandic textile artists have sought their education and inspiration abroad – in the neighboring Scandinavian countries or in Scotland. The visual arts can be understood internationally, but each culture appears to

have a predilection for a given set of symbols it finds particularly relevant. These symbols can have a clear, literal referent, or they can be hidden in the use of abstracted forms or spatial arrangements. With the application of such symbols, one can note certain tendencies – toward roughness or simplicity, religious intensity or decorative effects, for example.

In recent decades, textile art in Iceland has been profoundly influenced by the sudden swelling and diversity of influences from abroad, representing a wide variety of cultures. This exposure has been intensified by our strategic location between Europe and North America. Still, our abiding strength, stability and identity continue to rest in our unique natural landscape and climate, as well as in our deeply rooted literary and linguistic heritage.

This article concerns itself primarily with the textile artists of Iceland who are working in weaving. It does not by any means express the totality of contemporary Icelandic fiber work, however. Rather, it is meant to honor the age-old technique of handweaving – of the interlocking of threads peculiar to this process – and to show some of the possibilities of this form rendered by artists in Iceland today. Weaving continues to form part of an important living tradition that is still very much “in our blood”. □

Hildur Hákonardóttir is a textile artist and the former head of the textile department at the Icelandic School of Arts and Crafts in Reyjavík.

CONTEMPORARY ICELANDIC WEAVING

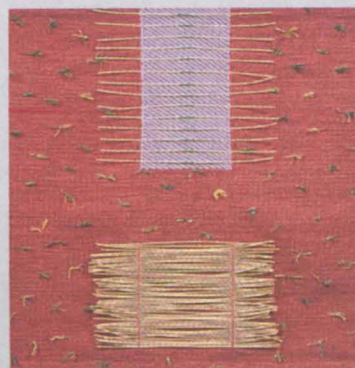
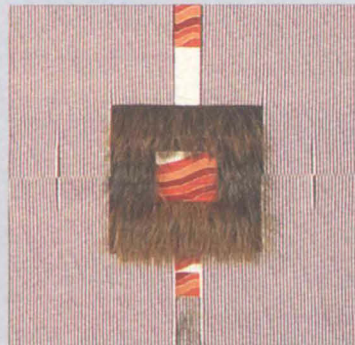
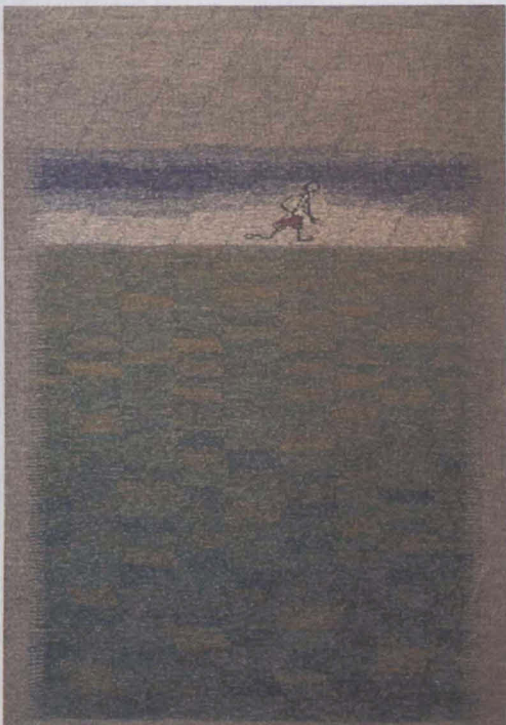

Far left: “The Runner” by Hildur Hákonardóttir. PHOTO BY THE ARTIST.

Top left: “Taurus” by Ásgerdur Búadóttir. PHOTO BY KRISTJAN PETUR GUDNASON.

Bottom left: “Sonata” by Guðrún Gunnarsdóttir. PHOTO BY GUDMUNDUR INGOLFSSON.



GISLI GESTISSON, THE NATIONAL MUSEUM OF ICELAND

Glit

An Icelandic Inlay Technique

by Louise B. Heite

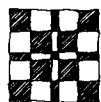

Glit is an Icelandic variation of dukagång, the well-known Scandinavian embroidery weave. Like dukagång, glit is an inlaid pattern on a plain weave ground. Both glit and dukagång can

be woven on a rosepath or straight twill threading. In both techniques, the inlay weft appears on the face of the fabric and is tied down by every fourth or sixth warp. Glit, however, is woven face up, while dukagång is woven face down. This simple difference makes glit much easier to weave.

Glit works both the pattern weft and the ground weft in pairs of passes. Pairs of pattern weft picks are followed by pairs of ground weft picks (see illustration). The pattern weft skips over the first tie-down warp of each pass and under the rest, and then returns, again skipping over the first tie-down warp and under the others. In areas where color blocks join, the pattern wefts alternate in wrapping around and covering the tie-down warp.

The origins of glit in Iceland have been lost. The weave was used extensively in the 19th century for saddle covers. These large, elaborately worked blankets were draped over ladies' saddles. Glit was also traditionally used in utilitarian

decorative objects such as shelf curtains. Glit was seldom if ever used for clothing.

Traditional glit was worked with a light-colored pattern weft on a dark ground. Icelandic sheep provide a palette of natural wool colors, from white and cream through brown, gray and black. Spinners often blended fibers of different colors to produce an even wider variety of natural shades. Dyed colors, however, were precious and expensive. Glit, which places the pattern yarn entirely on the surface of the cloth, made the costly dyed yarn go as far as possible.

Traditional glit patterns are built of squared blocks, which result in geometric designs reminiscent of cross-stitch embroidery. Diagonal and curved lines in glit weaving have sawtoothed edges.

The work of Gudrun Vigfusdóttir, a weaver in Isafjordur, Iceland, inspired my jacket with a flowered border. I designed the plain

weave ground after the remarkably light and fluffy fabric from her studio. Icelandic wool is extremely lofty and surprisingly strong. The jacket fabric resembled window screening when it was on the loom, but bloomed beautifully when I washed it in warm water. □

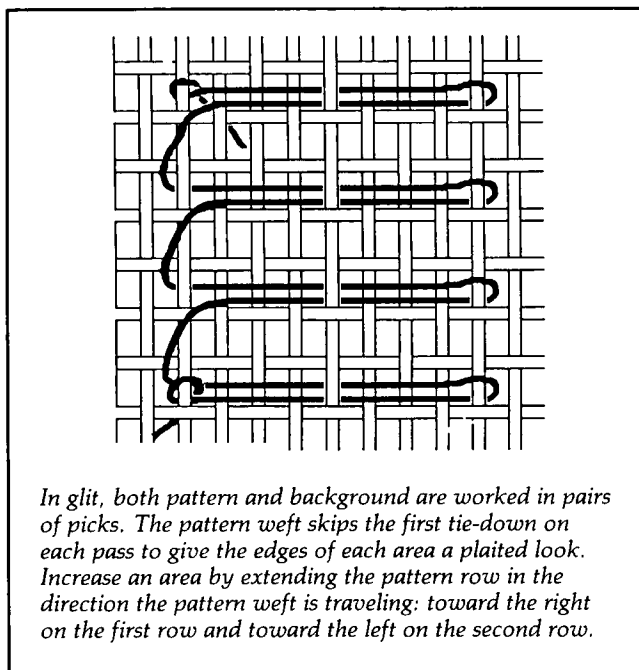

In glit, both pattern and background are worked in pairs of picks. The pattern weft skips the first tie-down on each pass to give the edges of each area a plaited look. Increase an area by extending the pattern row in the direction the pattern weft is traveling: toward the right on the first row and toward the left on the second row.



For the instructions for this Glit Coat by Louise Heite, please see the Instruction Supplement.
YARN COURTESY LOUISE HEITE YARNS



Krossvefnadur (rölakan)

A Nordic Tapestry Technique



Flat woven rugs with tapestry designs in a technique called *rölakan* have long been popular with Nordic weavers. In fact, *rölakan* is considered one of the oldest known weaving techniques; it is found in ancient cultures from Egypt and the Near East to Central America, and has had an unbroken tradition in Sweden from prehistoric times.

The term *rölakan* is derived from the word for the woven textile hung on the wall above a bench for protection from drafts. More recently, *rölakan* has been used extensively for rugs and wall hangings. It is a tapestry technique in plain weave with different colored weft yarns interlocking with each other. There are different ways to weave *rölakan*. The oldest methods interlock wefts on every row, making a non-reversible fabric with ridges on the reverse side. A later technique interlocks wefts on alternate sheds for a smooth, reversible fabric.

In Norway, *rölakan* is called *ruteväv* (checkered weave) and in Iceland it's *krossvefnadur* (cross-weave). This runner by Áslaug Sverrisdóttir is a variation called *krossvefnaour, eins á baeoi boro* (cross-weave with both sides alike) in which the wefts are interlocked on alternate rows, also known as Norwegian *rölakan*.

A unit of *rölakan* is a span of two, four, six, or eight warps and as many weft shots as needed to square it. The weaving is done with butterflies, one for each color area across the width of the warp. Start on the left side with the left edge warp lowered. Place the first weft color in the shed with the butterfly traveling toward the right. Lay in each color in turn without interlocking them. Beat the row on a closed shed.

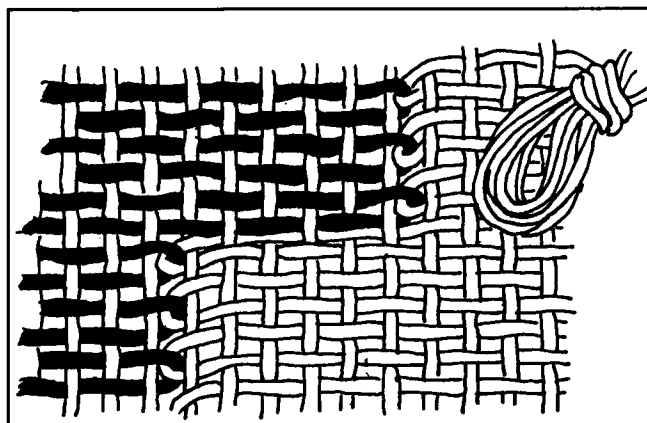

On the next shed, tuck in the tails before weaving with the butterflies. Then work each butterfly from right to left, starting from the right edge, this time interlocking adjoining colors. When this row is completed, beat on a closed shed. Repeat these two rows, interlocking only on the second row. When the pattern changes, two wefts overlap in the same shed to move the join to a new place. To finish a color, secure the ends by tucking them under a few warps.

See Ulla Cyrus-Zetterström's *Manual of Swedish Handweaving* for a discussion of *rölakan* variations and how to weave them. □

Above: *Detail of traditional rölakan. Courtesy Astri Gauffin Feist.*
PHOTO: CHARLES TALLEY.



Cross-weave Tapestry by Aslaug Sverrisdóttir. For further details on weaving this runner, please see the Instruction Supplement.
SETTING: DANISH DESIGN CENTER, BOULDER, COLORADO



From BYZANTINE To BAUHAUS

by Kirsti Rantanen

IT IS NO easy task to define the present state of the textile arts in Finland. What we see and experience today is the result of a long historical process, the sum total of a variety of complex factors. One must take into consideration the relationship between our textile arts and our geographical location, the extremes of the Nordic climate, our remoteness from international contact, and our delicate position between East and West here in the northernmost reaches of Europe.

One would have to consider the situation of human beings, the circumstances of life in ancient times. How one fought to win one's bread during the all too brief summer. How one struggled to survive against the long, dark, unyielding winter half-year. One must take into account the *Kalevala*, our national epic poem. The bitter lessons of frugality; the necessity to be intensely practical in order to survive. One must also contemplate the deep influences of the medieval church, followed by the puritan resolve of the Lutheran reformation – both forces mitigated by the presence of Orthodoxy in the eastern part of the country. One

has to consider the wars we have experienced, rulers from both the east (Russia) and west (Sweden). Our determination in spite of dire privation (*sisu*, the national virtue). Our very recent transition from an agrarian economy to an urban, industrial society.

One must also think about the forest, the lakes, the vast stretches of arctic wilderness. Endless winter nights; the short, wondrous summer. Our voyage in this modern world has been a journey between forest and city, winter and summer, night and day – Bauhaus and Byzantium. And it continues between these elusive poles.

In Finland the textile arts are an integral part of Finnish design and arts and crafts movements alike. Educated at the University of Industrial Arts in Helsinki, the newly graduated textile artist will have received a comprehensive training in both textiles as handicrafts and in textiles as a

Above: *Selling handwoven fabrics at the open-air market in Helsinki.* PHOTO: CHARLES TALLEY. Right: *"A Study With No Ends"* by Kirsti Rantanen. Wool, hair, flax. PHOTO: AUVO LUKKI.



component in industrial design. Both are taught side by side in the university's textile department. The newly minted graduate than has the opportunity to embark upon a career in either aspect of textile design and production.

Professional textile artists are organized as members of the Finnish Association of Designers, ORNAMO, together with fashion designers, interior architects, industrial designers and craftmakers. In addition, textile artists have their own affiliate organization, TEXO, which celebrated its 30th anniversary last year. The textile profession is, of course, much older than the organization. Professional textile artists have been active throughout this century, with training facilities organized after World War I. Our historic roots are in the countryside, among peasant women with their glowing *ryijy* (*rya*) rugs. Even to this day, the *ryijy* is a vital source and symbol of identify and self-confidence to contemporary textile artists.

The recent Fall, 1986, exhibition of the TEXO organization, provides an important focal point to consider the direction of contemporary Finnish textile art expression. The show consisted of some 40 pieces by 27 professional textile artists. The oldest participant had completed her studies in the 1930s, while the youngest member of the group had received her diploma only a few months before the exhibition. Hence, the show embraced a wide variety of personal styles and aesthetic viewpoints.

Here some of our leading artists had the opportunity to demonstrate the continuing vitality and adaptability of our rich *ryijy* tradition. In the hands of an artist such as Katri Mattila, it exudes the archaic simplicity of the earliest functional rugs while at the same time reflecting the sophistication of a contemporary minimalist painting. With an artist like Maisa Kaarna, the *ryijy* is transformed into a constructivist composition, in which the artist has carefully considered the effects of light upon the various fibers in the work. In a separate one-person exhibition, Irma Kukkasjärvi presented an entire collection of *ryijy* rugs in which she had explored the possibilities of relief formed by the rug's clipped pile surface.

So the *ryijy* is alive and well and thriving in Finland. Exploration into the construction of its knots, the possibilities of its pile, the textures formed by the reflection and absorption of light upon its surface all serve as important sources of discovery and renewal for textile artists in our own time. Such exploration serves to ally Finnish textile art with work produced internationally.

At the same time, our textile arts are very much rooted in a tradition of functionalism. They have retained their character as elements in interior environments, as integral elements in an architectural setting. Textile "art" then begins to serve a genuine function. Indeed, contemporary works produced for public environments represent some of the finest statements achieved in the medium by our artists.

For us, textile art is also an important and active component in the exploration of aesthetic space. The TEXO exhibition provides a number of examples in this search for sculptural expression. Netta Hobin works with a series of sculptured cardboard images flooded with light, while Norma Heimola has created a "village" of fiber-filled glass houses pulsating with the radiance of Byzantium. A dazzling "pillar" of fiber sculpture by Ari Snellman-Hanninen

pierces the exhibition space dramatically. This "Frost Column" is a veritable piece of the Finnish winter taken indoors and assembled in the exhibition hall. Concern for nature has served as the inspiration for a number of works by this artist, whose expressions of glistening ice and winter's frozen seas grace the walls of a number of our public buildings. Her works are as practical as they are inspired; the artist uses only nonflammable materials and is very concerned with the effects of the environment upon her completed sculptures.



Members of the younger generation of textile artists appear to be moving away from this concern for practicality. They are not so convinced by our puritanical tradition of using only natural materials. Rather, they view the use of the loom, of the weaving process, as only one possibility. A means to an end. Such daring has been a long time in coming. For some artists, such as Laila Leppanen, everything can be said in the construction of a weave. Her linen works produced on a damask loom "read" like a Bauhaus diploma in terms of their design and execution. Other artists, such as Kirsti Jouhki, are fascinated by the possibilities of the knitting machine. Her work involves an exploration of the mystical world of colors in three-dimensional space. Jaana Pesonen's research results in a constructivist seascape of lyrically contrasting white and blue linen washed surfaces. Elsewhere in the exhibition one notes exploration in discharge and resist dyeing, serigraphy, appliqué, patterned cloth and other techniques not usually associated with our traditions. Here, it is the individual statement of the artist which is most important.

The textile arts possess a language all their own; the possibilities of communication are endless. What, for example, is the "message" of the exhibition's youngest participant, Soili Arha, in the two full-sized translucent boats she has constructed of cloth? For us Finns, boatbuilding is an ancient skill. The boat represents the necessity of crossing water, of making contact. Perhaps that is the sense of her illusory vessels. Making contact between elusive poles. Between Bauhaus and Byzantium. □

Kirsti Rantanen is a textile artist, author and lecturer. She is head of the School of Applied Arts in Helsinki. Translation: Kaisa Viljo.

CONTEMPORARY FINNISH WEAVING



Top left: *"Towards Light"* for the Myyrmäki Church, Kristiina Nyrhinen. PHOTO BY THE ARTIST.

Top right: *"Haukivesi"* for Varkaus City Library, Maija Lavonen. PHOTO: SIMO RISTA.

Left: *"The Crosswell"*, Ari Snellman-Hänninen. PHOTO: RAUNO TRÄSKELIN

Facing Page

Left: *"Three Mini Ryas"*, Irma Kukkasjärvi. PHOTOS: HEIKKI TUULI.

Right: *"The Night of Crocodiles"*, Nina Nisonen. PHOTO: RAUNO TRÄSKELIN

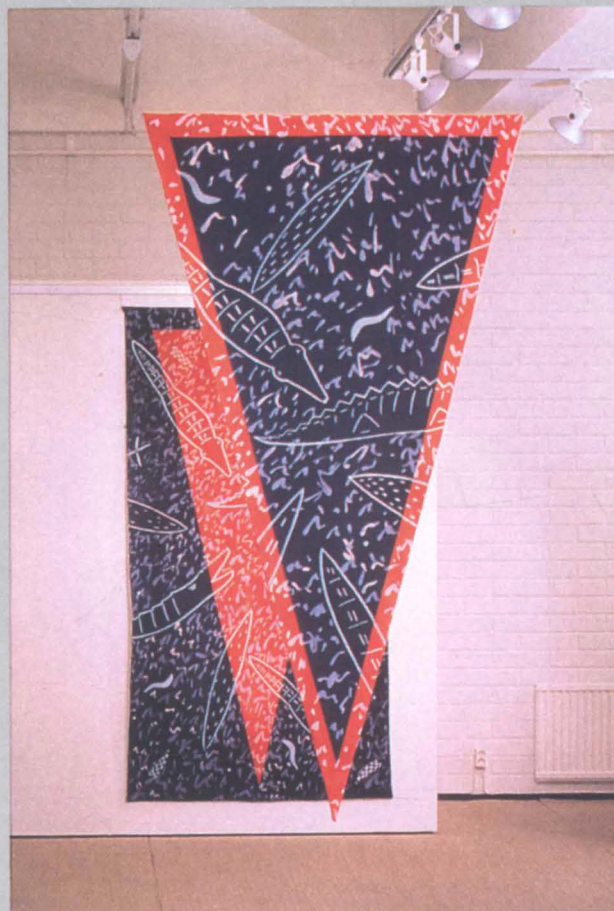

Artist and Industry A Cooperative Effort

PART OF the high profile commanded by Finnish weaving and design results, in part, from the necessity of manufacturing products for sale in the rest of the world. While textile art did not begin to reemerge until the '20s and '30s under the auspices of the Functionalist movement, the reawakening of interest luckily coincided with the industrialization of the textile industry. Because artists at that time had a desire to democratize the arts for the common man, they designed for the industry which would make this possible.

One of these artists was Dora Jung, who left a lasting mark on Finnish textiles through her creative efforts and dedication to industry. She worked only in damask, choosing to explore all its structural and expressive pos-

sibilities. Working within the limitations of one weave structure and confining herself to the use of linen (except during World War II, when she used paper for weft because linen was unavailable), she developed an independent artistic expression which transformed the context in which contemporary textile art was viewed. In his *Contemporary Textile Art: Scandinavia*, Charles Talley writes, "Her great skill, dedication, and integrity leave a lasting impression. Through her work she enhanced the prestige of textile art expression and challenged its limitations. As such, she was truly a revolutionary force in the field."

—*Contemporary Textile Art: Scandinavia*,
by Charles S. Talley

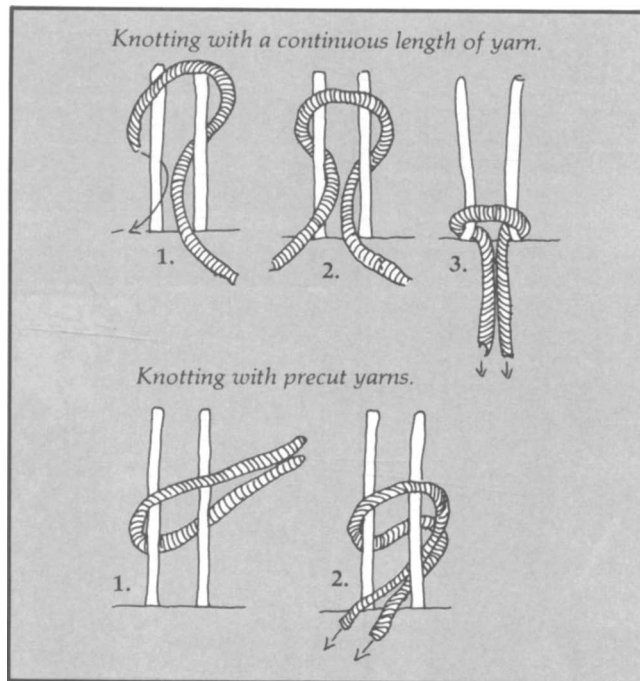

Finnish Ryijy (Rya)



Of all the Scandinavian textile forms, rya is the most recognized. Rya rugs and wall hangings have been very popular weaving projects for many years, and not just in Scandinavia! The word *rya* is related to the Swedish word for goat hair, the English word for rug, and the German word for fur, indicating an interesting evolution.

Though we know rya today as a rug and wall hanging, as late as the 19th century rya was a very functional heavy coverlet for the bed. It was used pile-side down for warmth; the side which we think of today as the back was the face, often decorated with initials, dates and geometric patterns. Around 1800, decorative ryas began to appear with the pile side as the show side.

The ground weave today is usually weft-faced plain weave, but in the past it could also have been a goose-eye twill. The pile is knotted around warps in a rya knot (also called a Ghiordes, Smyrna, or Turkish knot). It is worked in one of two ways. Sometimes a continuous length of yarn is knotted around the warps and

wound over a rod between knots. The rod is removed and the loops are cut (or sometimes left uncut). More often, the pile yarn is cut into short lengths before it is knotted. In this technique, it is easy to change colors freely across the row. A variation of this method combines loops and cut pile by starting with double-length strands which are folded in half before they are knotted.

The pile is usually wool, but traditional weavings also employ linen, cow hair, cotton rags, or unspun locks of wool. Spacing of the knots can vary. The final density of the pile will depend on whether the knots are close together or far apart. Placing a few rows of the ground weft between rows of pile results in a thick pile, while a larger number of ground weft rows produces a flatter texture. The length of the pile also affects its fullness. For wall hangings, rya pile is often combined with flat woven area, to give the weaving a textured surface.

The knot used in weaving rya is tied around two warps and can be made in a number of ways. Knotting from a continuous length of yarn is

one method; the knotting yarns are threaded on a needle or made into a butterfly and worked right to left as illustrated above. No trimming of the ends is necessary if a guide is used along the fell of the fabric or if subsequent knots are measured to match the previous knot.

Precutting the yarns to equal lengths is another rya knotting technique which is thought to have developed in Scandinavia. This method lends itself to subtle color blending. The pile yarn is measured by wrapping it around a stick; this measurement determines the length of the pile yarn. The yarn is then cut along the length on one side to make the individual pieces. Several colors can be selected for each knot and tied around two warps as illustrated.

For more on rya weaving, please refer to *A Rug Weaver's Sourcebook* and to *The Techniques of Rug Weaving* by Peter Collingwood. □

Pile Vest by Merja Winqvist. Please see the Instruction Supplement for further details.



Poppana!



In Finland, old rags were recycled to weave sheets, and the word for sheet from the Karelian region of Finland gives us the name *poppana*. The Finns found that cutting rags on the bias made a more pliable filling material, which when woven produced a soft, velvety fabric for comfortable bedding material. Brushing this fabric created an even silkier surface.

Today, instead of cutting our own, we are inclined to purchase bias strips on flat spools in a variety of colors. Poppana, once a material of economy, has become an exclusive commodity which weaves up easily and beautifully into bags, table mats and garments.

The instructions for this Poppana Bag by Riitta Mäkinen can be found in the Instruction Supplement.

**"The world spins on an Ashford,
now it's weaving on them too!"**

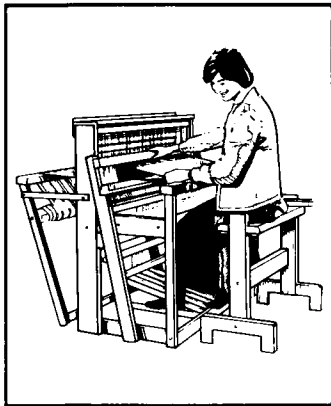

ASHFORD

*The foremost
name in spin-
ning equip-
ment is now
offering their
complete line
of weaving
looms and
accessories
to the
American
weaver.*

- 4H 6 treadle
- 38" weaving width
- built in raddle
- front and back cloth apron included



Distributed in US by:

Fibercraft Imports

61 State Road • N. Dartmouth, MA 02747
617-993-2240

Call or write for free catalog • Dealer Inquiry Invited

EDGEMONT YARN SERVICE INC.

Mail Orders
Serving Weavers for over 30 Years

Maysville Carpet Warp—Fillers
Yarn—Mercerized Pearl Cotton
Rags—Special Close Outs

Wholesale & Retail \$1.00 Samples

Box 240 Edgemont
Maysville, KY 41056
606-759-7614



Daruma Home Twister



Weavers, knitters—in fact, all fiber people can use the Home Twister to wind two or more strands of yarn to create a third one totally different from the yarns which go to make it up. This handy unit will add a rewarding new dimension to your fiber projects.

No. T717 \$39.95
(Add \$4 for shipping & handling)



SCHOOL PRODUCTS CO., INC.
1201 Broadway, New York, N. Y. 10001 (212) 679-3516

TRY THE FINNISH FINISH.

We named our service Ihana ("lovely" in Finnish) because for centuries Scandinavians have brushed their woven woolens for added beauty and warmth. Now you can, too. For more facts on how this unique finishing process can enhance your work—plus a small brushed sample—send \$1.00 to Ihana Brushing Service, Dept. HM7, 1037 S. University, Denver, CO 80209. Or call (303) 744-0411.



ihana
BRUSHING SERVICE

Send with \$1.00 to Ihana Brushing Service
Dept. HM7, 1037 S. University
Denver, Colorado 80209

Name _____

Address _____

City _____

State _____ Zip _____

WILDE



WOOLY

-  2, 4 & 6 ply in 8 earthy natural wool colors.
-  natural white wool in various weights and plies.
-  2 & 4 ply wooly Berber yarns in 6 rustic colors.
-  2 & 4 ply top dyed Berber in 6 tweed colors. **NEW!**
-  sturdy 3 ply wool in 16 subtle shades.
-  fine 2 ply wool for warp or weft in 28 custom dyed colors.
-  the Heavyweight—a bulky wool yarn in 9 bold colors.
-  soft, pure wool clothing yarn in 8 undyed natural shades & 18 muted colors.
-  all wool novelty yarns in 12 colors to coordinate with our fine 2 ply and soft clothing yarns.
-  carded wool in 5 natural and 9 dyed colors.

Send \$4.00 for Sample Cards
Dealer Inquiries Invited

WILDE[®] YARNS

3737 Main Street, Dept. H
Philadelphia, PA 19127

A Tradition in Spinning Since 1880



401 South Ann Street
Little Falls, New York 13365

WHEELS, LOOMS, FIBERS, DYES, ACCESSORIES
N. Y. State Fleece and Mohair

RETAIL—MAIL ORDER—CLASS SCHEDULE
Send Long SASE and \$1.00 for Catalog

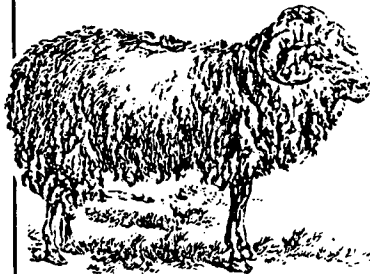

Handcraft Wools Limited

HANDCRAFT WOOLS...2 shops to serve you...

Our original Streetsville location is now for in-store shopping only. Phone # (416) 828-1488. Hours 9-4 Tues. to Sat.

Our new Minden shop is for in-store and all mail-order & shipping. Phone # (705) 286-1942. Hours 9-4 Mon. to Sat.

Please send for your free yarn, fibre and equipment catalogue.

Box 458, Minden, Ontario, Canada K0M 2K0



THE SWEDISH HANDCRAFT ASSOCIATIONS *SCANCRAFT*

own Mill since 1856

Highest quality yarn of natural fibers:
wool, cotton, linen, lintow, blends of cotton and linen,
rugwarp of linen and cotton.
fishyarn 20/6 unbl.
Sample cards \$17

Also available BERGA looms with accessories
Write for brochure and pricelist.



Lillemor Schou
P.O. Box 215
Oakton, VA 22124
(703) 620-4036
Berga
Representative

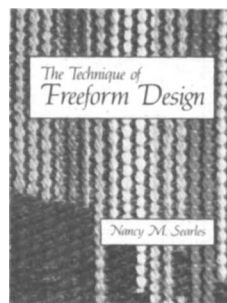

\$15.95 plus \$1.50
postage & handling

The Technique of Freeform Design
Nancy M. Searles

- Weave freeform designs by using four harnesses!
- Simple 4-harness threading & treadling system
- 16 techniques derived from familiar weaves
- Detailed instructions
- "Insights" column with valuable tips

ORDER FROM: WEAVER'S WAY
P.O. BOX 230
CROWN POINT, IN 46307

— AUTHOR AVAILABLE FOR WORKSHOPS —

A Textile Resource Guide to the Nordic Countries

compiled by Charles Talley



THE FOLLOWING GUIDE lists major museums, schools, galleries, shops and publications in Denmark, Finland, Iceland, Norway and Sweden. It is provided to assist the person who would like more information about summer courses, books and magazines. No guide is ever complete, and this one is no exception. But it should provide a good starting point for your own inquiries, correspondence and visits.

No endorsement is made of any of the products or services mentioned herein, and no major source has been intentionally omitted. If you have additional resources, please let us know.

If you are interested in travelling to the Nordic countries to study weaving for either a short summer period or an academic term, be sure to inquire well in advance. Note that most schools will welcome a limited number of foreign visitors, but that the language of instruction is nearly always the home language of the country involved.

Special thanks to Kirsti Rantanen (Finland) and Hildur Hákonardóttir (Iceland) who prepared the sections on their respective countries.

Tours

A number of special-interest tours are available for the person who would like to have first-hand experience of the Nordic textile arts. While no attempt is made here to endorse or evaluate any particular tour, the following list is made available for the interested reader.

Academic Travel Abroad, Inc., 3210 Grace St. NW, Washington, DC 20007. (800) 556-7896.

Finnair Special Interest Tours, c/o George Garber, Finnair Airlines, 10 E. 40th St., New York, NY 10016. (212) 689-9300.

Scandinavian Arts Tour, c/o Joann Tallarovic, Flagstaff Travel, 508 N. Humphreys, Flagstaff, AZ 86001.

Smithsonian Associates Travel Program, P.O. Box 37235, Washington, DC 20013.

Sweden Tours, William Henriksen, 33266 Road M, Mancos, CO 81328.

Vesterheim Workshops, c/o Lila Nelson, Curator of Textiles, Norwegian-American Museum, 502 W. Water St., Decorah, IA 52101.



FINLAND Museums

Åbo Konstmuseum, Puolalapa-
rken, 20100 Åbo 10. Tele:
921/330954.
Hvitträsk, Luoma,
Kirkkonummi. Tele: 2975/779.
Museum of Applied Arts,
Korkeavuorenkatu 23, 00130
Helsinki. Tele: 90/174 455.
National Museum of Finland,
Mannerheimintie 34, 00100
Helsinki. Tele: 90/664 306.
Nordic Cultural Center,
Suomenlinna. Tele: 90/668 154.
Seurasari Open-Air Museum,
Helsinki. Tele: 90/484 712.
**Verkaranta Arts & Crafts
Center**, Koti-Ja
Taideteollisussukceskus,
Verkatehtaanatu 2, 33100
Tampere. Tele: 931/37 161.

Schools

Åbo Hemslojdläroinstitut,
Tervahovinkatu 6, 20810
Turku. Tele: 921/353683.
**Fredrika Wetterhoffin Kotiteol-
lisuusopisto**, Palokunnankatu
9, 13101 Hameenlinna. Tele:
917/69331.
**Kuopion Koti-Ja
Taideteollisuusoppilaitos**,
Piispankatu 8, 70100 Kupio.
Tele: 971/113284.
**The Office of Finnish Handi-
craft Organizations**, Temp-
pelikatu 15 A 5, 00100
Helsinki. Tele: 90/493345.
*Note: Umbrella organization
encompassing 181 local
handicraft centers nationwide.
Most schools offer classes in
weaving, but for the most part
in the Finnish language only.*



Pirkanmaan Kotityo,
Hameen-Satakunnan
Kotiteollisuusyhdistys,
Rongankatu 2, 33100 Tampere.
Tele: 931/37161. *Instruction in
English available.*
**The University of Industrial
Arts in Helsinki**, Hameentie
135, 00560 Helsinki. Tele:
90/75631.
Varpapuu-Varpalooms,
Jasperintie 7, 46800

Myllykoski. Tele: 951/56594.
Instruction in English available.

Galleries, Shops, Etc.

Annikki Karvinen, Unioninkatu
30, Helsinki. Tele: 90/662 214.
Artisaani, Unioninkatu 28,
00100 Helsinki 10. Tele: 90/665
225.
Finnish Design Center, Kasar-
minkatu 19, Helsinki. Tele:
90/626 388.
**The Friends of Finnish Handi-
craft**, Suomen Koaityon
Ystävat, Tamminiementie 3,
00270 Helsinki. Tele: 90/482
010.
Helsky, Annankatu 16, 00120
Helsinki. Tele: 90/605 265.
Kalevala Koru, Unioninkatu
25, Helsinki.
Neovius Yarns, Kalevankatu 1,
Helsinki. Tele: 90/6944 925.
Ryijypalvelu, Kasarmikatu 34
A. Tele: 90/660 615.
Sokeain Myymalat,
Annankatu 16 and Unionin-
katu 27, 00120 Helsinki. Tele:
90/656 389.
Tellervo Oy, Uudenmaankatu
19-21, 00120 Helsinki. Tele:
90/603 154. *Folk costumes and
accessories.*

Publications

Form Function Finland,
Korkeavuorenkatu 19A, 00130
Helsinki. Tele: 90/171 621.
English language quarterly.
Kotiteollisuus, Tempelgatan 15
A 5, 00100 Helsinki. Tele:
90/449 210 or 449 467.



NORWAY Museums

Historisk Museet, Fredriksgate
2, 0164 Oslo 1. Tele: 02/41 63
00.
Kunstindustrimuseet, St. Olavs-
gate 1, Oslo 1. Tele: 02/20 35
78.
**Nordenfjeldske Kunstindustri-
museet**, Munkegaten 5, 7000
Trondheim. Tele: 075/21 311.
**Norske Kunst og Kultur-
historiske Museet**, Pilestredet
15, Oslo 1. Tele: 02/20 14 02.
Norwegian Folk Museum,
Museumveien 10, 0287 Oslo 2.
Tele: 02/55 80 90.
**Vestlandske Kunstindustri-
museet**, 5000 Bergen.

Schools

Bergens Kunsthåndverksskole,
Stromgate 1, 5000 Bergen. Tele:
05/21 28 35.
Holmen Gård, Norges Husflid-
slag, PB 3693 GMB, 0135 Oslo
1. Tele: 02/19 79 68.
Oslo Fylkeshusflidslag, PB 9606
Egertorget, 0128 Oslo 1. Tele:
02/42 10 75.
**Statens handverks og
kunstindustriskole**, Ullevalsvn.
5, Oslo 1. Tele: 02/20 12 35.
Statens Laererskole i forming,
Cort Adalersgate 33, Oslo 2.
Tele: 02/55 82 02.



Vesterheim Workshops, Lila
Nelson, Curator of Textiles,
Vesterheim, 502 W. Water St.,
Decorah, IA 52101. (319)
382-9681.

Galleries, Shops, Etc.

Brukskunstsentret, Karl
Johansgate 11, Oslo. Tele:
02/42 43 70.
Heimen A/S, Kr. Augusts gate
14, Oslo.
Husfliden, Møllergate 4, Oslo.
Tele: 02/42 10 75.
Ikat, Skovveien 29, 0257 Oslo
2. Tele: 02/43 10 43.
Sigrun Berg's Vevstue, Dam-
stredet 5, 0177 Oslo 1. Tele:
02/20 80 41.
**Verkstedutvalget Kunsthand-
verkerne**, Arbeidergata 4, Oslo
1. Tele: 02/42 23 61.

Publications

Kunsthåndverk, Norske Kunst-
handverkere, Peder Claussens-
gate 7, 0165 Oslo 1. Tele: 02/44
12 64.



SWEDEN Museums

Kulturen, Tegnersplatsen, Box
1095, 221 04 Lund. Tele: 46/15
04 80.



Nordiska Museet, Djurgården,
Stockholm. Tele: 08/22 41 20.
Rohsska Museet, Vasagatan
37-39, 411 37 Göteborg. Tele:
031/18 22 30.
Skansen, Djurgården, Stock-
holm. Tele: 08/789 85 00

Schools

Handarbetets Vänner
vävskola, Djurgårdsslätten
82-84, 115 21 Stockholm. Tele:
08/67 10 73.
Högskolan in Borås, Insti-
tutionen för textil ö
konfektion, Box 874, 501 15
Borås. Tele: 033/16 40 00.
Konstfackskolan, Box 27116,
102 52 Stockholm. Tele: 08/67
95 50.
Konstindustriskolan,
Göteborgs Universitet,
Kristinelundsgatan 6-8, 411 37
Göteborg. Tele: 031/20 87 65.
Sätergläntan, Hemslojdens
Gård, 790 30 Insjön. Tele:
0247/400 95.
Stenebyskolan, Box 44, 660 10
Dals Långed. Tele: 0531/404
21.
Stiftelse Capellagården,
Vickleby, 380 60 Färjestaden.
Tele: 0485/361 32.
Vävstolsfabrikan Glimåkra,
Box 125, 280 64 Glimåkra.
Tele: 044/430 00.



Galleries, Shops, Etc.

Konsthantverkarna, Mäster
Samuelsgatan 2, Stockholm.
Tele: 08/11 03 70.
Kulturhuset, Sergels Torg,
Stockholm. Tele: 08/14 11 20.
Libraria Konsthantverk,
Västerlånggatan 48, Stock-
holm. Tele: 08/20 29 04.
Stockholms läns Hemslojd,
Drottninggatan 18-20,
Stockholm. Tele: 08/11 75 49.
Svensk Hemslojd, Sveavägen
44, Stockholm. Tele: 08/23 21
15.

Textilgruppen, Hornsgatan 6,
117 20 Stockholm. Tele: 08/43
30 72.

Publications

Form, Nybrogatan 7, 114 34
Stockholm. Tele: 08/63 59 20.
Hemslöjden, Sturegatan 29,
114 36 Stockholm. Tele: 08/21
64 25.
Väv Magasinet/Scandinavian
Weaving Magazine, Viking
Trading Co., 1304 Scott St.,
Petaluma, CA 94952. (707)
762-3362.



DENMARK Museums

Kunstindustrimuseet, Bredgade
68, Copenhagen. Tele: 01/14 94
52.
Nationalmuseet, Fredriksholms
Kanal 12, Copenhagen. Tele:
01/13 44 11.
Turid uthaug, Danish Weaving
Center, Fjelstrupvej 34, 6100
Haderslev.

Schools

De Danske Husflidshøjskole,
5300 Kerterminde.
Den udvidede Højskole,
Skolevej, 4690 Haslev.
Engelsholm Højskole, 7182
Bredsten.
FO Vaeveskole v/ Inge
Kronslev, Mosede Bygade 10
A, 2670 Greve Strand.
Hadsten Højskole, 8370
Hadsten.
Hojlund Vaeveskole, Mary
Knudsen, Hojlund 79, V.
Sottrup, 6400 Sønderborg.
Landsforeningen, Stoftrykker
og Vaevelauget, Gl. Mønt 25,
1. sal, 1117 København K.
Nøtten Vaevekursus,
Banegardsgade 5, 8000 Århus.
Skals Håndarbejdsskole, 8832
Skals.
Skolen for Brugskunst,
Linnésgade 2, Copenhagen.
Tele: 01/13 22 58.
Smedegårdens vaevestue,
Jyllandsgade 16, 6700 Esbjerg.
Struer skolen, Vesterled 7, 7600
Struer.
Vaev 48, Centrum for
Vaevning, Smallegade 48, 1370
København K.



Vaeverske Tove Søby, Fredrik-
shavn.
Vaeveskole, Birgit Olsen, Gl.
Kongevej 91, 1. sal, 1850
København V.
Vaeveværksted, Karen Thor-
wald Nielsen, Lyongade 21, st.,
2300 København S.
Vestjyllands Højskole, Velling,
6950 Ringkøbing.

Galleries, Shops, Etc.

Danish Handicraft Guild,
Haandarbejdets Fremme,
Vimmelskæft 38, 1161
København K. Tele: 01/13 66
10.
Dansk Kunsthåndverk,
Amagertorv 1, Copenhagen.
Tele: 01/32 32 49.
Den Permanente, Vester-
brogade 8, DK 1620
Copenhagen. Tele: 01/12 44 88.
Galleri for Kunsthåndverk,
Kompagnistraede 17, 1208
Copenhagen. Tele: 01/32 81 81.
Garntex, Gothersgade 109,

1123 København K. Tele: 01/13
47 19.
The Textil Gallery og The Book
Trader, Skindergade 23, 1159
Copenhagen K. Tele: 01/12 06
69.



ICELAND Galleries, Museums

Árbaejaarsafn, Reykjavík. Tele:
(1) 8 44 12.
Galleri Langbrók, Bókhöfundustig
2, Reykjavík. Tele: (1) 62 20
50.
The National Art Gallery,
Sudurgötu 41, Reykjavík. Tele:
(1) 1 06 65.
The National Museum,
Sudurgötu 41, Reykjavík. Tele:
(1) 1 32 64.

Schools

The College of Art & Crafts,
Skiptóli 1, Reykjavík. Tele:
(1) 1 98 21.
Heimilisdnaðarskólinn,
Laufásvegi 2, Reykjavík. Tele:
(1) 1 78 00.



"DOWN UNDER" * iPRICES

For those lazy days of summer

PER POUND MAY 1 to AUGUST 31
COTTON TOP
AUSSIE
ON SALE \$10.00
INTRODUCING

For your FREE sample send SASE, for complete
samples send \$2.00, or send dealer inquiry to:

The Weaverbird
P.O. Box 142
Grafton, OH 44044
(216) 926-3551
Outside Ohio: 1-800-FOR-WOOL

California Colors
1075 W. 20th St.
Upland, CA 91786
(714) 982-9600



AYOTTES'
DESIGNERY
CENTER SANDWICH, N.H.

HANDWEAVING
STUDIO & SHOP

ANNOUNCING the completion of
our greatest achievement
"HANDWEAVING WITH ROBERT AND ROBERTA"

We teach you how to plan a weaving
project, select yarns, quantities
needed, warping, setting up your loom
easily and weaving step by step in
your home one lesson at a time at your
own pace until you attain the level of
achievement you desire. We also stock
all supplies for immediate delivery
and we are personally available for
further help if needed. For complete
details, send a self-addressed stamped
business size (4 1/8 x 9 1/2) envelope
to Ayottes' Designery, Dept. H-Kit,
Center Sandwich, N.H. 03227.



Looms

We carry a complete line of equipment for weaving, spinning and machine knitting by the following manufacturers:

Ashford Norwood Schacht
Cranbrook Leclerc
Harrisville Louet

We pay the first \$50 of freight charges.

Send \$2.00 for our complete Mail Order Catalog and a current schedule of classes and workshops.



THE VILLAGE WEAVER

5609 Chaucer • Houston, TX 77005

(713) 521-0577



Goverlet Co.

- Wheels
- Looms
- Accessories
- Dyes
- Books
- Domestic & imported fibers
- Serendipity handspun yarns
- Handwoven coverlets

SEND \$2.00 FOR SPINNING CATALOG OR COVERLET BROCHURE

P.O. BOX 02-616
7135 S.E. 32ND AVE.
PORTLAND, OR 97202

The best in textile and art weave yarn from Finland

Helmi Vuorelma

Wool Blanket Yarn (brushable)
Loop Mohair (brushable)
Takana Finnweave Yarn 7/2
Ryjy Yarn 7/3
Kampalanka, 32/2 Fine Worsted
Tow Linen #4, 8, & 12
Line Linen 30/2, 16/2, 16, 20
Sail Linen Warp 8/3 (tubes)
Nyppylanka (Nubby Cotton)
Cotton Chenille 1.7
Seine Twine #6, 12, & 18
Cotton 20/2, 12/2, & 8/3

Pirkanmaan Kotityö

Cotton Poppa Cloth Bias Strips
Pirkka Tapestry & Rug Yarn
Toika Looms and Equipment
Sample cards \$1 each or 6 for \$5



Schoolhouse Yarns

25495 S.E. Hoffmeister Rd.
Boring, Oregon 97009
503/658-3470

Dealer inquiries invited.

Bockens Garner

SWEDISH LINEN YARNS

These well-known pure Linen Yarns for handweaving and lacemaking are now also available on your market through our distributor:

FREDERICK J. FAWCETT, INCORPORATED
1304 Scott Street, Petaluma, CA 94952



Holma-Helsinglands AB
SWEDEN

Calendar

CONFERENCES

- Divergence '87: "Pattern with Panache", biennial conference of the Michigan League of Handweavers, June 12-14, Concordia College, Ann Arbor, MI. Workshops: June 15-17. Write Michigan League of Handweavers, 1434 E. Cook Rd., Grand Blanc, MI 48439.
- Gulf South Fiber Conference, "Cotton Daze—Summer Haze", June 24-28. Louisiana State University, Baton Rouge, LA. Contact Cheryl McWilliams, 6337 Hickory Ridge Blvd., Baton Rouge, LA 70817.
- MidAtlantic Fiber Conference, July 10-12. Pre-conference workshops: July 8-10. Montclair State College, Upper Montclair, NJ. For registration information, write to Harriet Serenkin, 57 W. 68th St., Apt. 7, New York, NY 10023.
- Biennial Conference of Southern California Handweavers, "Threads of Time", July 10-12. Los Angeles Airport Hilton. Speakers include Gerhardt Knodel and Walter Nottingham. Pre-conference workshops July 7-9. For registration info write Threads of Time, 8241 Kirkwood Dr., Los Angeles, CA 90046.
- Alaska's first-ever Biennial Statewide Fiber Conference, July 24-26. Hosted by the Fairbanks Weavers and Spinners Guild. Pat Hickman will be conference speaker and will conduct a two-week workshop July 27-Aug. 7 on "Textile Sculpture/Construction: Containers to Costumes". Contact Penny Wakefield, P.O. Box 10104, Fairbanks, AK 99710.
- Basketry Conference, Aug. 9-14 at Appalachian Center for the Crafts, Smithville, TN. Workshops, seminars, demonstrations, exhibits, basket sales and more. Sponsored by the Center and Press de LaPlantz. For registration information, send a \$.39 LSASE to Press de LaPlantz, P.O. Box 220, Bayside, CA 95524. (707) 822-6009.
- Minnesota Federation of Weavers and Fiberartists Annual Conference, Sept. 25-27. Theme is "Northern Lights and Shadows", celebrating color in its many aspects. Keynote speaker Nell Znamierowski will conduct a 2½-day post-conference workshop. Extensive exhibit and demonstrations of Finnish fiberart by the Ladies of Kaleva. Hosted by the Range Fiberart Guild of Virginia, MN. Contact Kathy Rensink, 320 S. 2nd St. W., Aurora, MN 55705.
- "Craft in the 80's: The Medium and the Market", American Craft Council Southeast Annual Conference, Oct. 14-17 at Arrowmont School of Arts and Crafts, Gatlinburg, TN. Program will feature a production emphasis, an architectural orientation, and a singular one-of-a-kind art/craft object emphasis. Contact Sandra Blaine,

ACC-SE Conference and Exhibition Coordinator, Arrowmont School, P.O. Box 567, Gatlinburg, TN 37738. (See additional listings in the March/April issue.)

TO ENTER

- "Craftadventure '87". Contest and showcase of fine handwork in fabric and fiber. Show: Aug. 28-30 at New England Center, Eastern States Exposition, West Springfield, MA. Entry deadline: July 20. Write or call Craftadventure, 1305 Memorial Ave., West Springfield, MA 01089. (413) 787-0119.
- "Artwear '87", a juried competition sponsored by the Bellevue Art Museum, Bellevue, WA. Open to textile artists in U.S. Show: Oct. 17. All art should be available for sale. Entry deadline: July 1. Submit 5 slides and resumé to LaMar Harrington, Director, Bellevue Art Museum, 301 Bellevue Square, Bellevue, WA 98004. Include SASE for return of slides.
- "Spotlight '87: Southeast Crafts", juried exhibition sponsored by Arrowmont School and the Southeast Region of Ameri-

- can Crafts Council. All media. Juried by slides. Open to residents of AL, FL, GA, KY, LA, MS, NC, SC, TN, VA, WV. Entry deadline: July 14. Show: Oct. 14-Dec. 12 at Gallery, Arrowmont School. Contact Spotlight '87, Arrowmont School, P.O. Box 567, Gatlinburg, TN 37738.
- "Fiber National '87", Access to the Arts 7th annual juried fiber show, July 12-Aug. 7, Adams Memorial Gallery, Dunkirk, NY. Open to US resident fiber artists. Fee: \$20 for up to 3 entries, 2 slides/entry. Juror: Gerhardt Knodel. Entry deadline: May 30. For entry form send #10 SASE to Adams Memorial Gallery, 600 Central Ave., Dunkirk, NY 14048.
- "Kansas Fiber Directions '87" at Wichita Art Museum, Oct. 18-Nov. 15. Seventh annual juried fiber exhibition sponsored by the Wichita Handweavers, Spinners and Dyers' Guild and the Wichita Art Museum. Open to all Kansans, former Kansans, and residents of Metropolitan Kansas City, MO. Deadline: Sept. 4. Contact Kansas Fiber Directions '87, 2424 Gouverneur, Wichita, KS 67226.
- "Luckenbach Mill Gallery Juried Exhibition of Contemporary Crafts", Oct. 3-Nov. 1. Five basic craft media, up to 3 slides each

PLYMOUTH YARN THE ONE NAME TO KNOW FOR ALL YOUR CONED YARN NEEDS

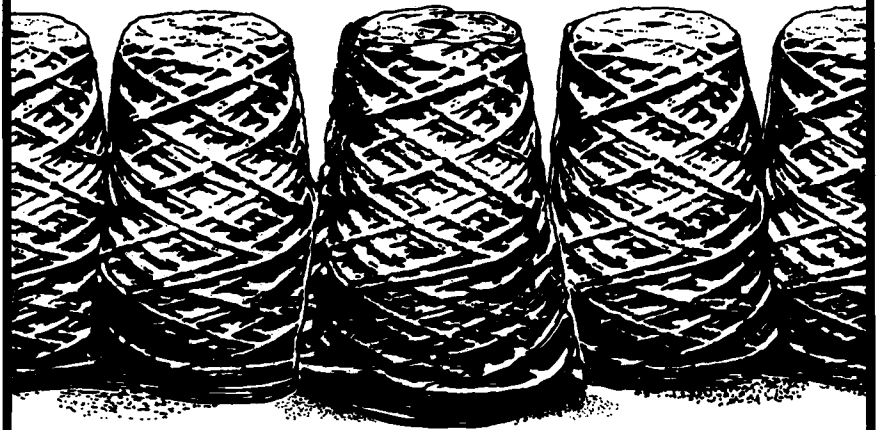

WOOLS • ALPACA • CASHMERE • ANGORA
CAMEL HAIR • ACRYLIC • WOOL/RAYON • BLENDS

PLYMOUTH YARN COMPANY, INC.
500 Lafayette Street, Bristol, PA 19007

Wholesale Only

(215) 788-0459

Color Card Album \$20.00

**SUMMERTIME!
AND THE
WEAVIN' IS
EASY**

*Just in time
for summer!*

Get all the materials to weave a lace stole to wear in those cool summer breezes

Included are natural white 100% merino wool for warp and natural 100% silk for weft.

You will be able to weave a 72" x 18" lace stole. It can be woven as a lace sampler or all one pattern. Its sure to attract compliments either way. Weaving patterns & suggestions also included

ONLY \$24.95 P.P.D.

*Illinois residents add 7% sales tax
Residents of MN, WI, IN, MI, OH,
Please add your appropriate sales tax.*

*Offer expires August 31, 1987
Send check or money order*

Serendipity Shop

2 Prairie St. Dept H
Park Ridge, Illinois 60068
(312) 692-7177

Send \$1 for our complete fibre arts catalog

The DROP SPINDLE

417 E. Central
Santa Maria, CA 93454
(805) 922-1295

Hand Dyed Yarns

*In Subtle & Outrageous Colors
Space Dyed & Natural
Silk, Mohair, Wool, Cotton & Novelties*



Wholesale Only; Samples \$2.00
Individuals send SASE for list
of stores carrying Drop
Spindle yarns.

CLEAN AMERICAN FLEECE

Brown, black, grey & white
Weekend Handspinning Workshops

THE RIVER FARM

"On the banks of the Shenandoah"

Rt. 1, Box 401, Dept.-H
Orders Only Please:
1-800-USA-WOOL
Inquiries (& VA Res.):
703-896-9931



Timberville, VA
22853
Mastercard/Visa
Free Brochure

silks
 cottons
 wools
 blends

■ ■ ■
CHOOSE FROM 53 DIFFERENT CONED YARNS
 ■ 400 TO 1500 YARDS PER POUND ■

wholesale only
Crystal Palace Yarns
 (A Division of Straw Into Gold)
 Dept. H7
 3006 San Pablo Ave.
 Berkeley, CA 94702

NEW!
**DOUBLE-WOVEN
TREASURES
from OLD PERU**
by Adele Cahlander

Lavishly illustrated with history
and full instructions! \$22.00

**Finishes in the
Ethnic Tradition**
by Baizerman and Searle \$7.50

- Textures and Patterns for the Rigid Heddle Loom, \$6.50
- Moorman Inlay for the Rigid Heddle Loom, \$3.00
- Hammock Making Techniques, \$8.00
- Latin American Brocades, \$5.00
- Latvian Mittens, \$10.50
- Cornish Guernseys and Knit-Frocks, \$8.00

(Send SASE for catalogue with further information.)
Postage and Handling: \$1.50 for first book,
50¢ for each additional book.

Dos Tejedoras
Dept. A, 3036 North Snelling Ave.,
St. Paul, MN 55113 (612) 646-7445

WHITAKER YARNS
in **NATURAL
FIBRE**
for
**HAND AND MACHINE
KNITTING AND WEAVING**

RIVERLINE BRUSHED MOHAIR - 68 SHADES
 CARRICK LOOPED MOHAIR - 33 SHADES
 KID BRUSHED MOHAIR - 28 SHADES
 COTTON CHENILLE - 15 SHADES
 SUMATRA CULTIVATED SILK - 32 SHADES
 2/16 LEVEN LINEN - 31 SHADES
 SCOTTISH CASHMERE - 24 SHADES
 WINDERMERE FANCY COTTONS - 13 NATURALS
 FIESTA COTTON SNOWBALL - 17 SHADES
 CANBERRA SILK NOIL - 15 SHADES
 2/6 2/12 2/24 MERINO WOOL - 39 SHADES

ALL AVAILABLE on CONE (RIVERLINE, KID,
 SUMATRA and CASHMERE on SKEIN/BALL ALSO)

WOOL, ALPACA, FLAX, RAMIE, CASHMERE, SILK,
 ETC. AVAILABLE in FIBER FOR HAND SPINNING.

Available from stores throughout
 the U.S. and Canada

GHW

GERALD H. WHITAKER INC.
P.O. Box 305
Niagara Falls, New York 14305
(Wholesale Only Please)

CALENDAR (continued)

of 3 pieces. Awards: \$1000. Fee: \$10. Deadline: June 5. Contact Janet Goloub, Historic Bethlehem, Inc., 501 Main St., Bethlehem, PA 18018.

□ "11th Fibers Unlimited Textile Competition and Exhibition", May 29-July 12 at Whatcom Museum of History and Art, Bellingham, WA. Sponsored by the Whatcom Textile Guild and the Whatcom Museum. Eligibility: Fiber artists in Washington State and British Columbia, any artwork that is fiber or textile related. Juror: Gerhardt Knodel. Fee: \$5/entry, 3 entries maximum. Deadline: May 15. Contact the Whatcom Museum, 121 Prospect St., Bellingham, WA 98225, (206) 676-6981, or the Whatcom Textile Guild, P.O. Box 403, Bellingham, WA 98227.

EXHIBITS, FESTIVALS, SALES

□ **Arizona.** Flagstaff, July 1-Aug. 1. "Fiber Celebrated, 1987". The 3rd biennial juried exhibit in conjunction with the Intermountain Weavers Conference. Juror: Charlotte Funk. At Northern Arizona University Art Gallery.

□ **California.** Los Angeles, through May 24. "California Classics: Maloof, Anderson, Kester's UCLA Fiber Greats". Honors 3 outstanding artists in the history of California craft/art including selected alumni artists who have contributed to the fame of the UCLA Textile Dept. At the Craft and Folk Art Museum, 5814 Wilshire Blvd.

□ **Monterey,** Aug. 11-16. Monterey Cnty. Fair Wool Show. Events include wool judging, spinners' demonstrations, fleece auction. New handcrafted division offers classes for handspun yarns, woven, knitted, crocheted and felted items. Juror: Lee

Raven. Wool judge: Martin Daly. At the Fairgrounds. For information write Monterey County Fair, 2004 Fairgrounds Rd., Monterey, CA 93940. (408) 372-5863.

□ **Colorado.** Denver, July 31. "Art To Wear V", an annual, juried fashion show of wearable art at the Colorado Gallery of the Arts, 5900 S. Santa Fe Dr., Littleton, CO 80120. (303) 797-5650.

□ **Massachusetts.** North Andover, May 17. 15th "Annual Sheep Shearing Festival" sponsored by the Museum of American Textile History. Includes sheep shearing, sheepdog demonstrations, crafts fair, the Great New England Spinning Bee, fleece judging and auction, live music, museum tours and food booths. At the Old North Andover Common across from the Museum. For information, call (617) 686-0191.

□ **Minnesota.** Minneapolis, May 8-June 21. "Scandinavian Art Weaves by American Weavers", a contemporary weaving exhibition by Phyllis Waggoner, Cathy Ingebretson, and Mary Anne Wise. At the American Swedish Institute, 2600 Park Ave.

□ **Nevada.** Reno, June 3-26. "Fiberations '87", annual juried show of the Reno Fiber Guild. Jones' Visitor Center, University of Nevada campus.

□ **New Hampshire.** New Boston, May 9-10. "New Hampshire Sheep Breeders Association 11th Annual Sheep and Wool Festival". Includes shearing, seminars and lectures, sheep dog demonstrations, sheep to shawl contest, and featuring the first New England Rare Breeds of Sheep Show and Sale. At the Hillsborough County 4H Youth Center. Contact Patricia Frisella, 282 Meaderboro Rd., Rochester, NH 03867.

□ **New Mexico.** Los Alamos, May 8-31.

"Textures". Handmade paper assemblages by Lois Dvorak, weavings by Irene Yesley. Fuller Lodge Art Center, 2132 Central Ave.

□ **New York.** Lockport, June 5-7. "100 American Craftsmen", juried exposition of fine craft: weaving, fashion jewelry, enameling, ceramics, batik, wrought iron, leather, fiber. At Kenan Center Arena, 433 Locust St.

□ **Oregon.** Salem, May 23. "Sheep to Shawl/Sweater". See the processes involved in turning fleece into fabric: shearing, picking, carding, spinning, weaving and knitting. Also demonstrations of tatting, rug braiding, bobbin lace, machine knitting, basketry and hardanger, children's activities, Angora rabbits, llamas, sheep and spin-in. Mission Mill Village, 1313 Mill St. S.E.

□ **Salem,** June 6. "We're Gearing Up At Mission Hill" is the theme of the grand opening of the Finishing Room Exhibition at the historic Thomas Kay Woolen Mill, the only woolen mill museum west of Missouri. At Mission Hill Village, 1313 Mill St. S.E.

□ **Virginia.** Alexandria, May 13-29. "Color, Texture, Form: Fiber '87", Potomac Craftsmen's annual fiber show at the Torpedo Factory Art Center, 105 N. Union St.

□ **Wisconsin.** Madison, May 1-29. "Madison Weavers Guild Annual Exhibition", sale (May 2-3) and exhibit of handwoven wearables, home furnishings, handspun yarns and more. Lutheran Campus Center, 325 N. Mills St.

□ **Canada.** Toronto, Ontario, July. Diane Sanderson, textiles, at The Guild Shop, 140 Cumberland St.

□ **England.** London, through June 7. "Ingunn Skogholt: Tapestries". Skogholt,

Full color range of

Bergå

Yarns for weaving

Spinneries of Sweden
Handicrafts Associations

IN STOCK

Filtgarn • Roma • Mobeltyygarn
Ryagarn • Hargarn • Gobelaggarn
Redgarn • Limbogarn • Lingarn
Linne maltvarp • Lintow

SAMPLE CARDS SET — \$15

Mail Order • Wholesale & Retail



1555 Fir S. • Salem, OR 97302
(503) 363-9665

Wholesale
Basketry
Supplies



- Round & Flat Reed
- Seagrass ■ Raffia
- Grass Twines ■ Palm Cordage ■ & More

Call or write on your business letterhead for a complete Price List.

Alliance Trading Co.
1021 R St., Sacramento, CA 95814
916 442 9225

MANUFACTURER OF:
UNIQUE WHEELS & LOOMS
FOR PROFESSIONALS
SPECTACULAR COLOR-RANGE
OF HAND-DYED YARNS
ALL DESIGNED BY
RACHEL BROWN

Rochel Brown's (505) 758-0433

RIOGRANDE
WEAVER'S SUPPLY

- Unusual apparel yarns for weavers & knitters
- Large selection of tapestry and rug yarns and dyed wools for spinners
- Excellent variety of wool, linen and cotton warps
- Raw, scoured, carded, & dealer for Gimakra, Schacht, & Howell Equipment
- Workshops with Rachel Brown
- Good prices with Bulk discounts
- American wools only

Send \$1 for complete catalog
PO BOX 2009H, TAOS, NM 87571

CALENDAR *(continued)*

Norwegian, is using tapestry to create large, abstract works for incorporation in architectural design. At the Crafts Council, 12 Waterloo Place.

INSTRUCTION

□ The Annual Ozark Basketry Seminar, July 30-Aug. 2, Berryville, AR. Reed and Natural Fiber Basketry with Pamela Janus. Oak Splint Basketry with Luke and Willow Block. For information and application, send SASE to Ozark Basketry Supply, P.O. Box 56, Kinston, AR 72742. (501) 665-2702.

□ Make a Basket From a Tree. Estel, Grace and Gertie Youngblood, white oak basket-makers from Tennessee, will lead a 5-day workshop, June 10-14 at The Caning Shop, 926 Gilman St., Berkeley, CA 94710.

□ Mendocino Art Center Summer Textile Classes: rug weaving, beginning and intermediate weaving, tapestry, fabric printing, ikat, basketry, lace weaves and brocades, machine knitting and more. Write P.O. Box 765, Mendocino, CA 95460. (707) 937-5818.

□ Brookfield Craft Center, Inc., offers a wide variety of craft classes and workshops for every ability and interest level. Write for complete description: P.O. Box 122, Brookfield, CT 06804.

□ Campbell Center for Historic Preservation Studies offers "Textile Conservation: Principles and Practices", June 15-19, and "Advanced Costume and Textile Conservation", June 20-22. Instructor: Helene Von Rosenstiel, New York City. Write P.O. Box 66, Mount Carroll, IL 61053. (815) 244-1173.

□ Harmonie Weavers, Inc., offers workshops: Double Weave by Betsy Blumenthal, May 2-3; and Finishing Techniques (and lecture on Color Usage) by Sallie Guy, June 12-14. Write Harmonie Weavers, Box 277, New Harmony, IN 47631. (812) 682-3578.

□ Harrisville Designs offers a wide range of week-long summer workshops: four-harness weaving (intro. & inter.), multi-harness weaving, color in weaving, rug weaving, Andean weaving, early American coverlets, tips and techniques, design. Write for complete description: Harrisville Designs, Harrisville, NH 03450. (603) 827-3996.

□ Weavers Guild of Minnesota offers a variety of classes in loom weaving, spinning, dyeing, garments, and related subjects. Write for schedule and course description: 2402 University Ave., St. Paul, MN 55114. (612) 644-3594.

□ The Weavers' School, Rt. 1, Fayette, MO 65248. Madelyn van der Hoogt, weaver-in-residence, offers intensive 5-day workshops focusing on multi-harness and drawloom weaving. Classes limited to 5 students; accommodations available at the school. Write for schedule and info or call (816) 248-3462.

□ Damascus Pioneer Craft School and Yarn Shop is offering these workshops: Raven's Tail Twining, Cheryl Samuel, July 6-10; Energetic Yarns, Mary Frame, July 14-16; Twill Tapestry, Joanne Hall, July 20-24; Designing Distinctive Garments, Jean Scorgie, Aug. 3-7. Write the school at 14711 S.E. Anderson Rd., Clackamas, OR 97015. (503) 658-2704.

□ Oregon School of Arts and Crafts offers

a variety of workshops in all media. Textiles include rug hooking, Japanese papermaking, the consummate cloth, tapestry, shibori. Write 8245 S.W. Barnes Rd., Portland, OR 97225. (503) 297-5544.

□ Penland School offers workshops in a variety of media including textiles with Randall Darwall, Bhakti Ziek, Janet Taylor, Tim Veness and others. Write for complete schedule: Penland School, Penland, NC 28765-0037. (704) 765-2359.

□ Arrowmont School of Arts and Crafts offers an extensive list of fiber workshops for summer: basketry, weaving, surface design, papermaking, shibori, spinning, quilting, tapestry, wearables and more. Write them at Box 567, Gatlinburg, TN 37738. (615) 436-5860.

□ Coupeville Arts Center is hosting "Fiber Forum", a workshop including 12 areas of fiber arts, Sept. 18-20. Contact Coupeville Arts Center, P.O. Box 611, Coupeville, WA 98239. (206) 678-4606.

TRAVEL

□ The Ancient Weaving World of Peru and Bolivia, Mar. 24-Apr. 8 or July 7-22. Visit remote Indian villages and weaving centers, Indian markets, Machu Picchu, Lake Titicaca. Led by Dr. Gary N. Ross and John Davis. Arranged by Holbrook Travel, Inc., 3540 N.W. 13th St., Gainesville, FL 32609. (904) 377-7111.

Calendar events of special interest to weavers are printed free of charge as a service to our readers. Please send your event information at least 10 weeks prior to the month of publication to "Handwoven Calendar", 306 N. Washington Ave., Loveland, CO 80537.

The Fiber Studio



• MILL ENDS • CLOSEOUTS •

Rug Wools, Chenilles, Cottons, Silks, Novelties, Shetlands and More.

- Brushed Mohair • Perle Cottons 3/2—5/2 •
- Berbers • 10/6 Rug Linen • Tahki Wools •

SPINNING FIBERS

New Zealand Fleeces • Wool, Yak, Mohair, Camel Hair, Alpaca and Silk Rovings • Flax
Looms • Wheels • Exotic Wood Buttons
• Studio Knitting Machines •

Yarn Samples \$3.00—Spinning Fibers \$3.00

Catalog \$1.00

Foster Hill Rd., P.O. Box 637
Henniker, NH 03242

603-428-7830 Open Tues.-Sat. 10-4

MAIL ORDER YARNS

NATURAL FIBERS and BLENDS



alpaca • wools • cottons
mohairs • rayons

Name brands and first quality mill ends for knitters, weavers and machines. Agents for LeClerc, Schacht, Harrisville, Ashford, Louet.

Over 500 colors and textures.

Send \$3.50 for samples of: Harrisville, Elite, Tahki, Plymouth, Crystal Palace, & more!

Periodic Updates • Quantity Discounts

ALSO AVAILABLE: Exotic fiber samples (approx. 150) of silks, angora, ribbon, cashmere, etc.—\$2.75

Bare Hill Studios

(Retail: Fiber Loft)

Rt. 111 (P.O. Building), P.O. Box 327
Harvard, MA 01451

*Bradshaw
Manufacturing Co.
Introducing
Lower Priced
Economy*

Stainless Steel Reed

write for price list

PO Box 5645

West Columbia S.C. 29171-5645

(803) 794-1151

WEAVE BEAUTIFUL RUGS AT HOME!

FOR PLEASURE and PROFIT

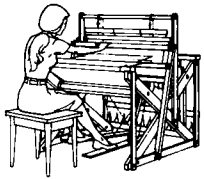

Enjoy the fascinating craft of weaving rugs in your home. Create your own serviceable rug designs for pleasure or profit. Always a year round market for your rugs in every community. Easy to operate floor model loom weaves 36" wide, comes already threaded, fully equipped...ready to weave. We furnish complete information on looms and all equipment with offer below.

Send 25¢ for descriptive brochure. You buy your supplies...carpet warps, rug fillers, shears, rag cutter, beam counter, looms, and parts at low factory direct prices. Also: rags - prints - and looper clips, in 10 and 50 lb. bales. If you now have a loom, please advise make and width it weaves.

OR RUG COMPANY, Dept. 4731

Lima, Ohio 45802

SAVE! FACTORY DIRECT LOW PRICES

bollweaver's

— Fiber Arts & Crafts Center —
Cress Creek Square Mall
790 Royal St. George Drive
Suite 115 — At Ogden Avenue
Naperville, Illinois 60540

(312) 357-3687

We're more than your typical yarn shop.

Please stop by and visit.

Davidson's OLD MILL YARN

Offering one of the largest selections in the country.

Mail-order or visit our retail store and mill outlet.

Samples of our own Old Mill wools, \$3.

OLD MILL YARN
P.O. Box 8, 109 Elizabeth
Eaton Rapids, MI 48827

THE WEAVERS' STORE

11 South 9th Street
Columbia, MO 65201
314-442-5413

1987 CATALOG NOW AVAILABLE
\$200

Huge selection of looms, spinning wheels, yarns, and great mill ends.



Portables — by Dorset

An American-made tradition for over 30 years.

We pioneered the extremely sturdy, cross-buck design that has been a distinguishing Dorset characteristic since our very beginnings.

These sturdy, **folding floor looms** have established a solid reputation for excellence and functional design.

Available direct from our workshop or at a few selected dealers and priced less than many other looms.



Dorset Looms

PO Box 520-H
Stillwater, NY 12170

Our free brochure is yours for the asking. Drop us a card or call Carol on 518/664-3668.

Warp-Aide

THE WARP WINDING WONDER

WARP ALONE

• RAPID • TROUBLE-FREE • EVEN TENSION •

CUSTOM MADE BY

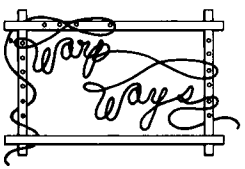

WRITE FOR FREE BROCHURE
\$10.00 REFUNDABLE DEPOSIT FOR V.C.R. DEMO

4961 CEDAR RAVINE
PLACERVILLE, CA 95667

Call Toll-Free
1-800-THE-LOOM
within Michigan (313) 547-9159
'til 10 p.m. EST, Mon., Wed. & Fri.

Freight Rebates to \$300 +

Handweaving Looms from
GLIMAKRA • NORWOOD
SCHACHT • LECLERC • BEKA
CRANBROOK

ASHFORD & PIPY CRAFT
Spinning Wheels

Institutional Inquiries Welcome

THE GOLDEN HEDDLE

1602 Rochester Rd., P.O. Box 761-H
Royal Oak, MI 48068





The Weaver's Knot

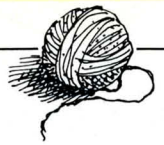

Handweaving,
Spinning, Basketry,
Folkwear, Dyes, Books,
Looms & Wheels
Catalog \$1.00

The Weaver's Knot
121 Cleveland St., Greenville S.C. 29601
Call 803/235-7747
Open Mon. thru Sat., 10 to 5:30



THE MANNINGS
Handweaving School
&
Weaver's Supply
Center

SUMMER SEMINAR

June 10, 11 and 12

ALLEN FANNIN

Production Handspinning:
The Reality

GRACE KABEL

Basketry

June 10 and 11

DOMINIE NASH

Warp Painting

SPINNING SEMINAR

Saturday, June 13, 1987

SUMMER WORKSHOPS

DEBORAH CHANDLER

Beginning Advanced Weaving
Workshop

July 20 - 24

MARIANNE GELDMEIER

Warp & Weave

June 22 - 26, Aug. 3 - 7

Overshot

July 13 - 17, Aug. 17 - 21

TOM KNISELY

Shaft Switching

July 27 - 31

Dyed Warp Rag Rug

Aug. 10 - 14

Call or write for more descriptive
information

LOOMS, SPINNING WHEELS, YARNS
EVERYTHING you need to get the
most out of your weaving and spin-
ning. Check our prices before you
place your next order. Discover for
yourself what we are supplying to
hundreds of pleased and satisfied
customers.

Catalog - 1.00

THE MANNINGS

P. O. Box 687
East Berlin, PA 17316

ORDERS: Outside PA 1-800-233-7166

OTHERS: (717) 624-2223

SUMMER STUDY OPPORTUNITIES

WEAVE AND SPIN IN MAINE



- Beautiful coastal location
- Small class & individual instruction
- Books, equipment & supplies

Friendship Farm Handweaving
HC-60 Bremen; Waldoboro, ME 04572

**HALIBURTON SCHOOL OF FINE
ARTS - The Ontario Summer School
in Cottage Country**

Weaving and Spinning Workshops
Wendy Bateman, Ted Carson, Stephenie
Gautstad, Lyn Milgram & Noreen Whyte
O.H.S. Spinning and Weaving
Certificate Program

Box 339, Haliburton,
Ontario K0M 1S0
(705) 457-1680 (ask for Edna)



COLLOQUY '87

Exploration of colors and feature using
"Common Warps" on multi-harness
looms. Hands-on and group sessions.
Resource person: Henning Waterston,
Seillans, France, a noted textile design-
er. June 29 - July 2.

Also other workshops from May to
October. Contact:

THE LOOMS

Far End, Shake Rag St.
Mineral Point, WI 53565
608-987-2277



**HD Harrisville Designs
Weaving Center**

Summer Workshops
June 29 to September 4

Study with great teachers:
Sharon Alderman
Ed Franquemont
Helen Jarvis
Nancy Lyon
Donna Muller
Bessann Triplett
Leslie Voiers
Virginia West
Nell Znamierowski

Write for free brochure.
Harrisville Designs
Harrisville, NH 03450



Scottish Studies Program
North Idaho College
Coeur d'Alene, Idaho
presents

**TARTAN WEAVING
WORKSHOP**
with Jan Crook

co-author of *The Tartan Books*
June 28-July 3, 1987

For further information:
Jan Crook
7457 Alder Avenue
Cotati, CA 94928
(707) 792-2921

19 87



THE WEAVERS' SCHOOL: Summer & Fall
classes in Introduction To More Than Four
Harnesses, Coverlets, and The Drawloom.
Also offered: individual instruction and
special classes for study groups. Inexpensive
room and board at the school, rural atmo-
sphere. For brochure write: Madelyn van der
Hoogt, Route One, Fayette, MO 65248.

CERAMICS
FIBERS
PHOTOGRAPHY
JEWELRY
PAPERMAKING
GRAPHIC DESIGN
DRAWING & PAINTING
VIDEO

*Southwest
craft
center*
300 AUGUSTA
SAN ANTONIO
TEXAS 78205
512/224-1848

PETER COLLINGWOOD
KAY MAXHAM
JANE DUNNEWOLD
ROBERT HILLS
CAT BRYSCH

OUTSTANDING STAFF
STIMULATING ATMOSPHERE
BEAUTIFUL HISTORIC CAMPUS
PERSONALIZED INDEPTH INSTRUCTION
NATIONALLY KNOWN WORKSHOP ARTISTS

Call or write for a brochure

one and two week workshops

June 8 - August 14, 1987

WEAVING (Kay Sekimachi, Barbara Eckhardt, Sharon Marcus, Albertje Koopman, Richard Daehnert, Kathy James)/BASKETRY/QUILTING/
SPINNING/SURFACE DESIGN/CLAY/METALS - JEWELRY/BLACKSMITHING/
ENAMELING/WOOD TURNING - CONSTRUCTION/DRAWING/PAINTING/
PAPERMAKING/PHOTOGRAPHY/BOOK ARTS

graduate/undergraduate credit
assistantships/scholarships
year round gallery exhibition schedule



ARROWMONT
School of Arts and Crafts
Box 567, Gallinburg, TN 37738 (615) 436-5860

Sievers

Learn how to Weave Free Lessons

No experience needed. Teachers from our School of Fiber Arts teach you. Here's how:

Buy a Sievers Floor Loom here on Washington Isle, Wisconsin, and while you are here you will receive, free, two full days of instructions. You will learn how to "dress" the loom, how to measure the length of warp, amount of filler, how to treadle, throw the shuttle. **You become a Weaver** and will advance as quickly as you desire.

Check into this exceptional opportunity. Send \$1 today (refunded) for complete details. We will also send you our latest Loom Catalog and the '87 School Brochure covering all of the Fiber Arts taught.

Do it right now—this can be so exciting and will open up new doors for you. For once, do something for yourself. Others have—shouldn't **YOU?**



Sievers

Iris Road
Washington Isle
Wis. 54246
(414) 847-2264



YARN BARN
CRAFTS SCHOOL

Martha Weatherbee

"The Brown Ash Shaker Basket" July 13
"The Canterbury Shaker Cat's Head Basket" July 14
"A Weatherbee Original Design Basket" July 15-16

Laura Volker

"The New York-style Buttocks Basket"
July 17 and 18

Arlene Mintzer

"Special Knitting Techniques" July 18 and 19

Stephen Zeh

"The Swing Handle Bucket Basket" and
"The Notions Basket" July 20 and July 22
"The Swing Handle Gathering Basket"
July 21 and July 23

Carla Starkey

"The Nantucket Basket" July 27-29
"The Egg Basket with Lid" July 30-31

Kit Frost

"Beginning Weaving" July 21-31 *
"Intermediate Weaving" August 3-7 *
"Beginning Basketry" August 10-14 *

Joanne Tallarovic

"Swedish Weaving Techniques" August 10-21

Betty Gaudy

"Transparency Weaving" August 24-26
"Battenburg Lace" August 27-29

Yarn Barn Crafts School

Box 408, Oquossoc, Maine 04964
207-864-5917 or 201-222-4991

* Continuing education credits available from the University of Maine.

TAPESTRY & COLOR WORKSHOP

with

GUNNEL ORESJO

Dynamic Tapestry and Weaving teacher from Sweden. She has studied with Malin Selander, and at Handarbetets in Stockholm. She taught in Sweden for six years before coming to the United States.

AUGUST 10 - 15, 1987

Workshop includes:

- 6 days of instruction in tapestry technique and safe, easy dyeing for glamorous colors; and
- All your yarn and dyes.

Complete price = \$95

Write or call for information.

Greentree Ranch Wools
163 N. CARTER LAKE ROAD
LOVELAND, COLORADO 80537
PHONE 303-667-6183

PENLAND FIBER '87

SUMMER - 6/1-10/9

RANDALL DARWALL/Weaving
JASON POLLEN/Surface Design
BHAKTI ZIEK/Weaving
JANET R. TAYLOR/Rug Weaving
NANCY CROW/Quilting
TIM VENESS/Fabric Design
DIANE ERICSON FRODE/Pattern Drafting
RUTH KELLY GAYNES/Weaving
EDJOHNETTA MILLER/Weaving
LISSA HUNTER/Basketry
NICKI HITZ EDSON/Knitting
SANDRA B. RAMSDALE/Weaving
LENORE DAVIS/Surface Design
GEARY A. JONES/Weaving
DAVID JOHNSON/Weaving
ELLEN KOCHANASKY/Wearable Art
PATTIE NEAL/Basketry
EMILY DUBOIS/Weaving
ANN MATLOCK/Spinning & Dyeing
SUSAN MORGAN LEVEILLE/Weaving
JEAN EBERT/Faux Finishes

PENLAND SCHOOL
Dept. HW
Penland, NC 28765
704/765-2359

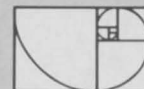



3054 North First Avenue - H
Tucson, Arizona 85719

Spin 'n Weave

(602) 623-9787

SHOP FOR SPINNERS & WEAVERS

Natural Fiber Yarns - Dyes - Books - Instruction
Knitting - Basketry - Spinning Wheels - Looms

YARNS FROM EVERYWHERE • FOR EVERYTHING
LOOMS FLOOR • TAPESTRY • TABLE • NAVAJO
SPINNING WHEELS and SUPPLIES
Spindles • carders • fleece • other fibers • weaving accessories • books

PENDLETON FABRIC CRAFT SCHOOL
Handweaving and Spinning Instruction • Write for brochure • College credit

THE Pendleton SHOP
HANDWEAVING STUDIO

P.O. BOX 233 • Jordan Rd. • Sedona • Arizona 86336 • 602/282-3671

FREE VIDEO

WIN WEAVING VIDEOS FROM VICTORIAN VIDEO

at these '87 conferences:
MIDWEST — Lawrence, KS, June 5-7
SO. CALIFORNIA — Los Angeles, CA, July 10-12
MID-ATLANTIC — Montclair, NJ, July 10-12
NORTHWEST — Vancouver, BC, Can., June 24-27

TO WIN:

- Stop by the GLIMAKRA LOOMS & YARNS booth and pick up your VVP #.
- Wear your # and find someone wearing a matching VVP #.
- Come back to the GLIMAKRA booth together and choose a free video—one for each of you.
- If you do not find a matching number, do not fret! Return your # to the booth at any time and see what you get! (It's worth \$10.00 towards the purchase of any VVP video tape.)

SEE YOU THERE! For our FREE CATALOG, call:
1-800-442-1122
(206) 385-7490
P.O. Box 1328
Port Townsend, WA 98368



J-Made and Proud of It

J-Made started designing and building looms and accessories in 1969. When we started we wanted to build all of our equipment so that we could be proud to put our name on it. We still work that way today.

J-Made's beautiful shuttles, pick-up sticks and shed sticks, spool racks, and other warping equipment can be seen in our accessory catalog (\$1.00).

Our exceptional floor looms have 4, 8, or 12 harnesses with worm gear brake systems and come in weaving widths from 45" to 72". We also have table looms in 4, 8, or 12 harnesses with matching floor loom conversions. All can be seen in our loom catalog (\$1.50).

Catalog prices refundable with purchase.

J-Made Looms

*P.O. Box 452 • Oregon City, Oregon 97045
(503) 631-3973*

June 5 - 7

CROSS ROADS

where weavers meet . . .
. . . suppliers, manufacturers, authors, and each other.

Where else can you meet over 50 suppliers and manufacturers with yarns, looms, wheels, dyes, fibers, books and more to sell? Browse through the exhibits and see the latest in fiber arts. This marketplace of activity is free and open to the public. Be there: June 5-7, 1987, Lawrence, Kansas.

For more information write: Crossroads, Box 334, Lawrence, KS 66044. In conjunction with the Midwest Weavers' Conference

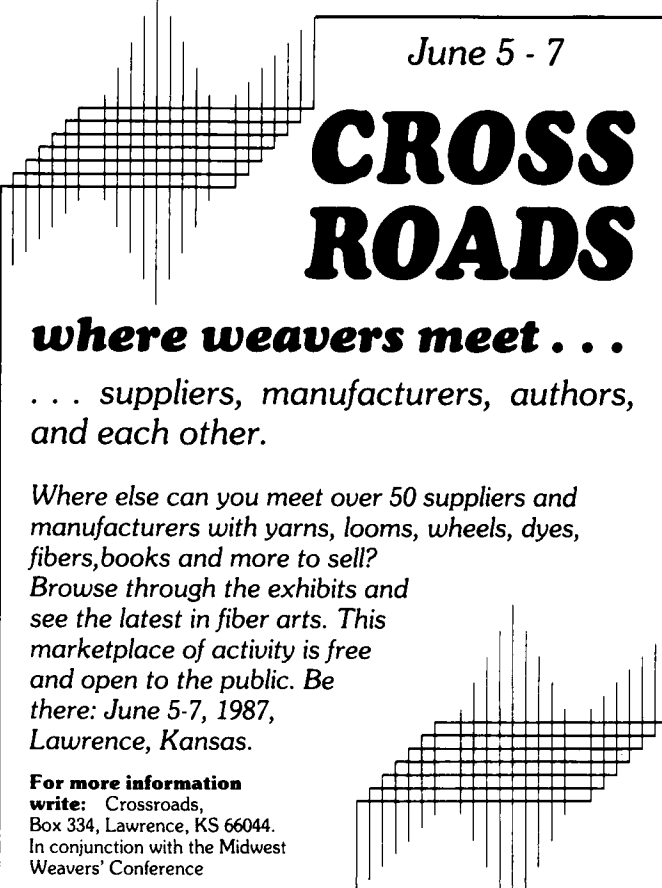

Readers share their programs

Computer Networking

by Carol & Stewart Strickler

We have had quite a volume of correspondence about computers and weaving during the past few years, and have often fallen behind in answering it and in working the ideas of other weavers into this column. This month we are going to mention a few of the programs we have received.

In the September 1985 issue we mentioned a drawdown program sent us by Joe Perrault for the Apple II computers, and we offered to send a listing to anyone who wanted one. Later, in the March 1986 column, we also offered a version of the same program modified to run on the IBM-PC and compatible computers. These listings are about seven pages long, so it requires some effort to get them typed in and mistakes corrected. Nevertheless, they work quite well, and many people have found them useful. It is interesting that, to date, we have sent out 47 copies of the Apple II version and 73 of the IBM version. They are still available to interested readers.

Several other weavers have sent us programs to share with readers who would like them. Katie Potter sent a program, written in Pascal, for doing calculations of warp and weft yardage and weights. She recently sent us a listing of an updated version with a number of improvements and said we could share it with others. Many of

the programs we have discussed before were written in BASIC, which is very easy to learn and is often supplied with a computer when you buy it. Pascal is a newer and very powerful language, originally designed as a tool for teaching computer programming. It is now the most-taught programming language in university computer science departments. To use it, you need to have a Pascal compiler for your computer, which usually means an extra purchase. Any readers who have such a compiler are welcome to a copy of Katie's program. It is written in Turbo Pascal, a particularly popular and inexpensive form of the language, created by Borland International, but the program should require little or no change to work with other versions of Pascal. We are actually a bit curious to know how many weavers do have Pascal available and whether there is a demand for programs written in that language.

Janice Linkletter sent us a listing of a drawdown program written for her Commodore 64 computer by her daughter, Sandra. (This program is in BASIC.) The program is menu-driven, i.e., at each stage it presents the user with a menu listing the various options, and an option is chosen by typing its number. It will do up to a 40 by 40 drawdown, either on the screen or on a printer. We do not have a Commodore computer so have

LENDRUM FOLDING SPINNING WHEEL

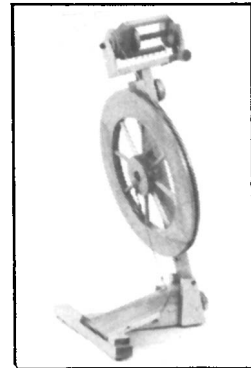

*6-speed versatility
modern*

*convenience
your spinning supplier or*

SOMETHING EXTRA SPECIAL

5400 Park Lake Rd.
E. Lansing, MI 48823

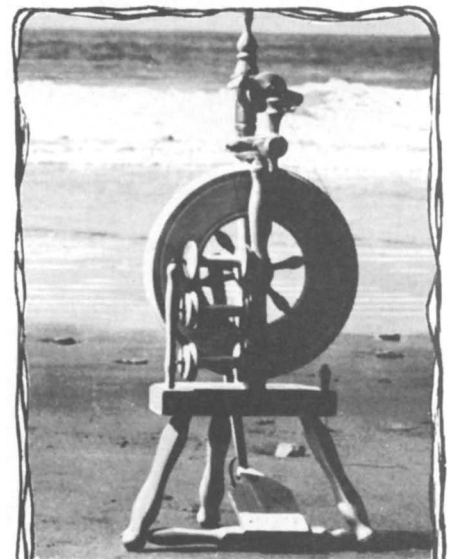

Special *Wee
Peggy*
Distributor Price—\$165.

Beautiful hardwood Kitset Castle Wheel from New Zealand. Scotch or double band tensioner, large 10mm spindle orifice, built-in "Lazy Kate", neat threading hook and a two-speed whorl.

LYDIA HILLIER
Weaving-Spinning Supplies, Inc.
P.O. Box 834, Ojai, CA 93023
(805) 646-3165

not been able to try out the program, but Janice sent us a copy of the printed output and it looks quite nice. The Commodore 64 has been a very popular computer because of its low price and considerable capabilities, but there has not been as much software available for it as there has for the Apple II and IBM-PC families. We appreciate the fact that Sandra and Janice are willing to share this program with other weavers. The listing is about two pages long, and we will be glad to send a copy to anyone who requests it.

Any of the listings mentioned above may be obtained free of charge, courtesy of the authors and of *HANDWOVEN*. We ask that you send a long self-addressed stamped envelope with a request for the particular program you would like. Readers outside of the USA who do not have access to US stamps may send just a self-addressed envelope and we will mail the listing. Please send your requests to "Interface", 306 N. Washington, Loveland, CO 80537.

We hope to mention in future columns several other letters, ideas, and programs we have received from readers. We also hope to have room and time to review some of the commercially available software released recently.

One other comment: one of our readers was recently the victim of a burglary. Here's her advice, shared in hopes that it will help protect the rest of us from the grief she's experienced:

Over Thanksgiving, someone broke into our house to steal all our computer equipment. They took all the hardware, software and listings in sight...I learned (or relearned) two things. First, ALWAYS keep your backup discs in a different location than the originals. Second, read your insurance policy carefully. (Our policy had a dollar limit on computer equipment that was less than the value of what was stolen. Apparently, these limits are common. Additional insurance may be

added. I think that typical insurance limits are above the value of most home computers, but it may be worth passing the caution on....)

Our insurance agent confirms that policies do commonly have categories that have limited coverage. According to her, \$3000 is a typical limit for home computers. At the cost of about \$18 per year, you *can* add an endorsement to your policy that will increase the maximum coverage on computer equipment to \$8000. A business endorsement may cover certain amounts on- and off-premises, but does *not* cover computers (or merchandise for sale). So we, too, suggest that you check your insurance coverage. You may need to add a policy endorsement if your computer equipment is worth more than the limit. □

Carol Strickler, new Technical Editor of HANDWOVEN, has been weaving for 20 years. Her husband, Stewart, first learned computer programming in graduate school in the 1950s. He now teaches chemistry at the University of Colorado.



**Poppana
Cotton Bias
Strips from
Finland**

45 exciting
fashion colors in
high quality fabric
from Pirkanmaan
Kotityo

Sample cards \$1



Schoolhouse Yarns
25495 S.E. Hoffmeister Rd.
Boring, Oregon 97009
503/658-3470

Wholesale and mail order



EATON YARNS

**THE BEST IN WEAVING
YARNS FROM FINLAND.**

MATTILA-YHTYMA YARNS:
Lenkki Mohair – looped (brushable)
Porri 5/2 Wool
Poppana – Bias cotton strips

HELMU VUORELMA YARNS:
Lenkki Mohair – looped (brushable)
Takana 7/2 Wool – Finnweave
Ryijy 7/3 Tightly Twisted Wool
Untuvainen 5/2 Wool – Brushable
Kampavilla 32/2 Worsted
Ensio II 3-ply Rug Wool
Tow Linen – 80 Wondrous colors
Line Linen 30/2
Cotton Chenille 1.7
Nyppylanka – Textured Cotton
Froteelanka – Textured Cotton
Cottons – 8/3, 12/2 & 20/2
Seine Twine – Unbleached & colors

WHOLESALE AND RETAIL
*Color Cards available –
Each yarn \$1.00*

Write to: Ann Eaton, EATON YARNS
at the Craft Skellar, Marymount College
Tarrytown, NY 10591
(914) 631-1550 or (914) 946-9180



**THE
WEAVER'S JOURNAL**

ETHNIC • TRADITIONAL • CONTEMPORARY
A quarterly magazine for textile craftspeople.
In-depth articles on fiber techniques lead both novice and
experienced weaver toward better design and craft.

USA: 1 year \$18 2 years \$34
Outside USA: 1 year \$22 2 years \$41
(US funds, please)

The Weavers' Journal
P.O. Box 14238, Dept. A, St. Paul, MN 55114

Handwoven

FROM  INTERWEAVE PRESS

General Instructions

Read the instructions thoroughly before beginning a project, and refer to the General Instructions, basic weaving books and other projects in this issue for further information as needed. The instructions assume that you have basic knowledge of weaving, can warp a loom, and can understand drafts. Symbols are used in each project heading showing loom requirements and techniques needed to complete the project.

 Rigid heddle loom. Specific directions are included for weaving the project on a rigid heddle loom.

 The number in the symbol denotes the number of shafts (harnesses) needed.

WARP & WEFT: The size, fiber and type of each yarn is listed, along with yardage per pound. If a specific brand has been used, it is listed with color names and numbers. Amounts needed are calculated in yards making yarn substitutions easier.

If you know the yardage you need and want to figure how many ounces or pounds to buy, divide the number of yards needed by the yardage per pound:

$$\begin{aligned} \text{yd needed} \div \text{yd per lb} &= \\ \text{lb needed} \times 16 \text{ oz per lb} &= \\ \text{ounces needed.} \end{aligned}$$

Example: if you need 1500 yd and the yarn has 2000 yd/lb, buy $\frac{3}{4}$ lb or 12 oz.

REED SUBSTITUTIONS: The number of ends per inch is very important. Most fabrics are sleyed one or two ends per dent, but sometimes a particular dent reed is used for a certain effect or to accommodate large or textured yarns.

WARP LENGTH: The length of warp needed for a project is figured by adding the finished length of the project, an allowance for take-up and shrinkage, and loom waste. Take-up is the amount lost due to the interlacement of the yarns in the weave structure. Shrinkage is the amount lost due to finishing processes. Loom waste is the amount needed to tie the warp on and allow the reed and heddles of a particular loom to function to the end of the weaving.

Our warp length measurements include finished length, percentage of take-up and shrinkage, and standardized loom waste of 27". Your own loom waste may be different, according to the requirements of your loom and warping technique. To figure loom waste, measure unwoven warp at the beginning and end of several of your proj-

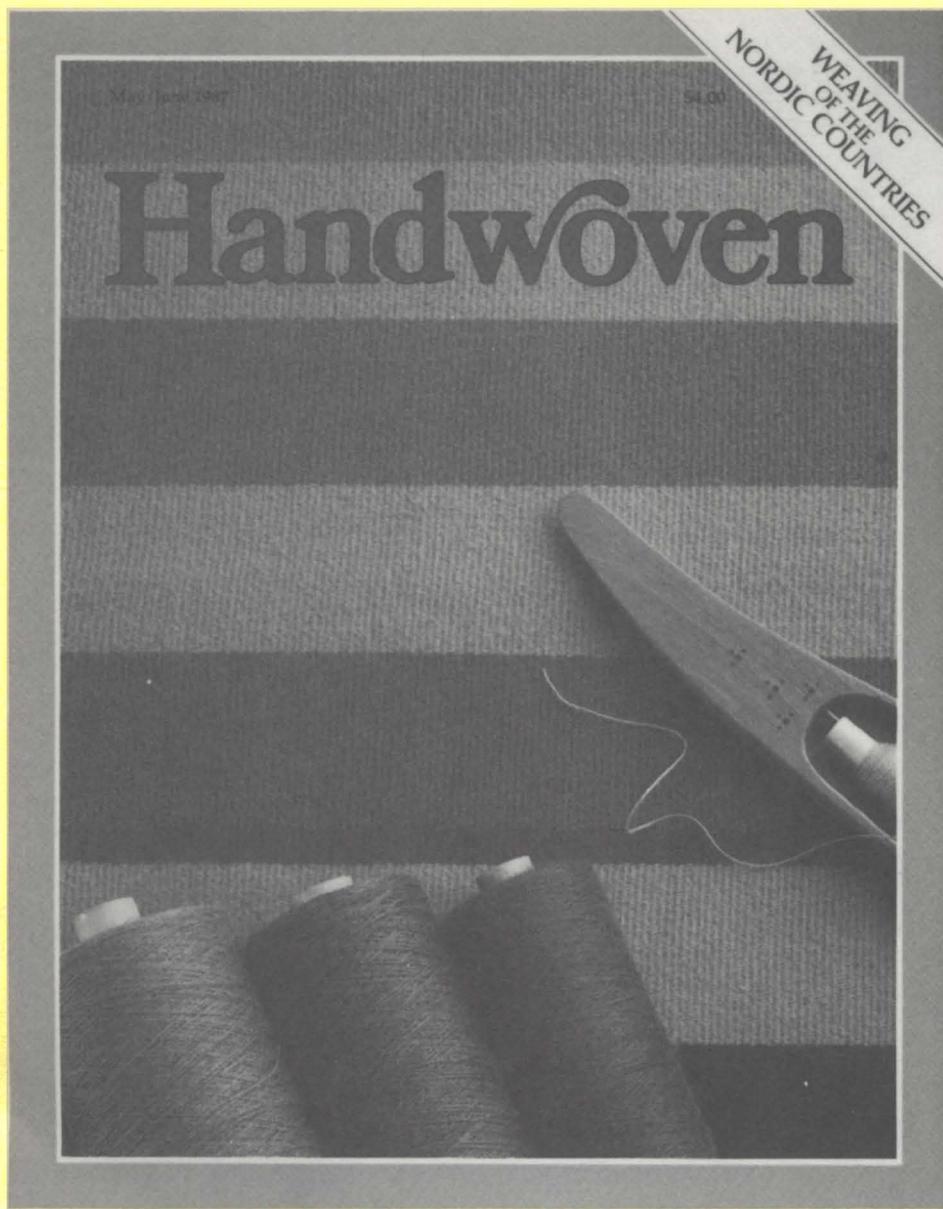

INDEX TO INSTRUCTIONS

Display Towel	I-4/43	Rose Jacket	I-9/56
Rag Table Runner	I-5/39	Lenten Pulpit Antependium	I-10/57
"Blue Chest of Drawers"	I-6/37	Bound Rosepath Rug	I-11/59
Hanging		Skillbragd Runner	I-12/61
Heritage Tablecloth	I-7/41	Glit Coat	I-14/65
Inspired Bedspread	I-7/49 & cover	Cross-weave Tapestry	I-15/67
Wool Shawl	I-8/51	Pile Vest	I-15/73
Black & White Rug	I-8/50	"Poppa" Shopping Bag	I-16/74
Tin & Tapestry Hanging	I-9/48	Tussah Silk Top	I-16/91

ects. Be sure to allow for knot tying and trimming of ends.

MEASUREMENTS: All measurements shown in the Weave Plans and discussed in the directions are taken *under tension on the loom* unless otherwise noted. Each measurement includes take-up and shrinkage so that when the piece is finished, the final size will be correct. Normal warp tension is tight enough to get a clear shed. Exceptions, such as weft-faced rugs and tapestries which require more tension, will be noted.

An easy way to keep track of progress on the loom is to keep a tape measure pinned to the weaving a few inches in from the selvedge. Punch two small holes at each inch mark and pin the tape to the weaving with two large-headed pins such as corsage or T-pins. Space the pins 3"-4" apart, moving the pin which is further from the edge of the fabric over the other one and pinning it closer to the edge. The pins leapfrog over each other. Do not let the tape measure wind on with the fabric on the cloth beam, or it will distort the tension.

DRAFTS: Threading drafts read from right to left and treadling drafts read from top to bottom. Threading repeats are shown by brackets. Sometimes double brackets are used to show a small repeat within a larger one.

Tie-ups are shown for rising-shed or jack looms. The small circle in the tie-up indicates that the shaft referred to *rises* when the treadle is pressed. To convert the tie-up for sinking-shed or counterbalanced looms, tie the treadles according to the *blank* squares. Countermarch looms use all the squares; the upper lamms are tied to the blank squares and the lower lamms are tied to the squares with circles.

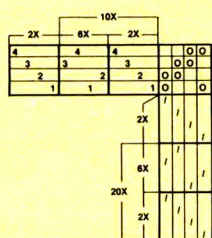

MAKING CHANGES: We encourage you to create, adapt and change the projects in *HANDWOVEN*. Although following the directions with no deviations will produce a copy of the piece shown, we try to give enough information to encourage you to use the directions as a starting point for your own design. Just remember, as designers do, to allow yourself plenty of leeway for any changes you make. Extra yarn and a longer warp are a wise investment when you anticipate *any* changes from the printed directions. Our publication, *Yarn*, will help when making substitutions, and weaving a sample of your intended design will provide you with needed information.

WEAVING WITH TABBY: Sometimes weavers use the terms tabby and plain weave interchangeably. In the directions we differentiate plain weave as the weave structure and tabby as the binder or background weft in pattern weaves such as overshot. In weave structures which use tabby, the plain weave treadles are noted separately, and only pattern rows are written in the treadling with a note saying "Use Tabby". "Use Tabby" means to alternate a row of pattern with a row of plain weave. The plain weave treadles alternate also. Two shuttles are needed, one for the pattern yarn and the other for the tabby yarn. The shuttles alternate row by row for the length of the pattern.

Remembering which tabby treadle to use can be frustrating until you know this trick: when the tabby yarn is on the left side of the fabric, use the left tabby treadle. When it is on the right side, use the right tabby treadle.

FLOATING SELVEDGES: Some weave structures don't make good selvedges; the weft doesn't catch the edge warps as often or as consistently as you would like for a good-looking and structurally sound selvedge. When this problem occurs, floating selvedges are often recommended. Floating selvedges are the first and last warp yarns sleyed in the reed but omitted from the heddles. Instead of rising and falling with the treadling, they float slightly above the bottom of the shed and are woven by hand. As the shuttle enters the shed it goes on top of the floating selvedge. As the shuttle exits the shed it goes under the floating selvedge. The thumb of the hand that receives the shuttle can assist by holding the floating selvedge up. In every row, the sequence is the same: over, then under. It's alphabetical. By the way, if you're treadling plain weave you don't need floating selvedges because the weave structure is already plain weave.

An easy way to keep tension on floating selvedges is to open out a paper clip into an S-shape, slip a fishing weight onto the lower loop, and hook the upper loop around the floating selvedge yarn in back of the heddles. Once you have it hooked, move the clip and its weight back and down below the warp beam where it will stay throughout the weaving.

FINISHING: Many weavers weave a few rows of scrap yarn at the beginning and end of their projects to keep the rows from loosening when the fabric is removed from the loom. After the fabric is cut from the loom, the scrap yarn is removed, and if the

edge has not already been finished on the loom, it is machine stitched, hemstitched or knotted.

Hemstitching. It is often convenient to use the tail of the weft yarn for hemstitching. At the end of a project, stop weaving with the shuttle at the left side. Unwind yarn from the shuttle 3½ to 4 times the width of the weaving. If this is too long to handle, use about 1-yd length at a time, working the ends into the fabric as invisibly as possible. Thread the end of the weft yarn into a tapestry (blunt) needle. Starting at the left side with the yarn lying on the woven fabric, take a stitch under 3-5 warps. Then, with the yarn lying on the warps above the edge of the fabric, enter the needle in the same place but bring it out 2-4 rows below the edge of the fabric. Repeat these two steps. If you are left-handed, start from the other side. Work across the row, and needleweave the end into the selvedge.

Before hemstitching the beginning edge of a project, a few rows must be woven to stitch into. Leave a tail of weft yarn long enough for hemstitching and, starting from the left side, weave about 1". Thread the tapestry needle and hemstitch across.

Hemstitching can also be done when the project is off the loom. In fact, when the length of the piece may have to be adjusted for any reason, such as when it must match another piece, it is wise to leave one end to be hemstitched later. Since the beginning edge cannot be hemstitched immediately, it is easiest to leave this edge for hemstitching off the loom. At the beginning, weave a few extra rows which can be raveled out later if need be. When the fabric is off the loom, mark the place you would like the hemstitching to be. Do the hemstitching between rows before raveling out the extra rows.

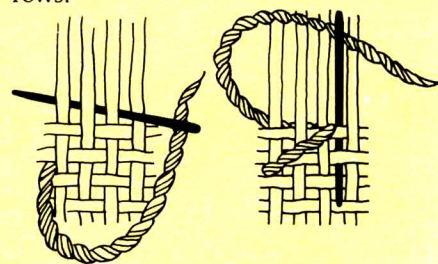

Step 1

Step 2

After the fabric is off the loom and the ends are protected from raveling, the fabric is finished by washing and/or pressing. Washing fluffs up the yarn, shrinks it somewhat, lets the yarns nestle into each other in the weave structure, and makes the set of warps and wefts into a cohesive fabric. It is an important step, not to be omitted. Our directions give the process the designer used to give the effect pictured. Other finishing methods may be used, but be sure to sample them first because they may affect both the hand of the fabric and the amount of shrinkage. □

YARN CHART. To help identify yarns and make creative substitutions in your weaving, use this yarn chart along with *Yarn, a Resource Guide for Handweavers* by Celia Quinn, available from Interweave Press.

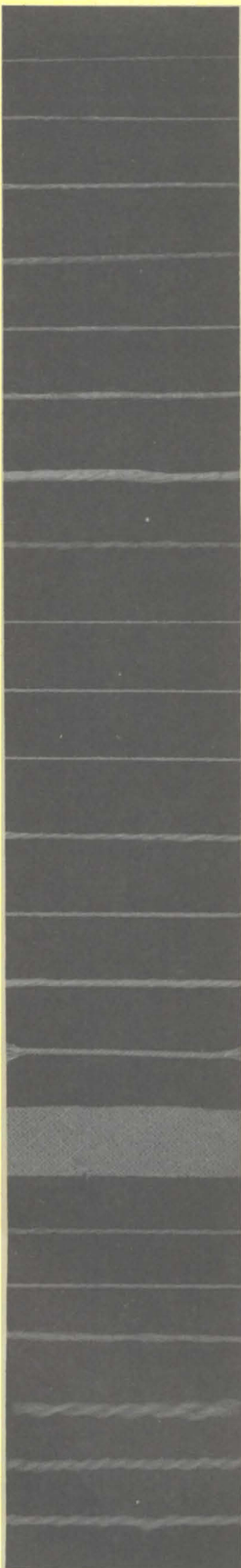

20/1 wet spun linen at 6000 yd/lb (12,090m/kg)
16/1 wet spun linen at 4830 yd/lb (9730m/kg)
16/2 linen at 2580 yd/lb (5190m/kg)
8/2 linen at 1200 yd/lb (2410m/kg)
8/1 wet spun linen at 2400 yd/lb (4850m/kg)
4/1 linen at 1440 yd/lb (2900m/kg)
Nm 8/5 linen rug warp at 470 yd/lb (940m/kg)
22/2 cottolin at 3170 yd/lb (6400m/kg)
20/2 mercerized cotton at 8400 yd/lb (16,920m/kg)
20/2 cotton at 7940 yd/lb (15,960m/kg)
Nm 16/2 cotton at 6350 yd/lb (12,800m/kg)
8/2 unmercerized cotton at 3200 yd/lb (6440m/kg)
6-ply cotton seine cord at 2740 yd/lb (5500m/kg)
Nm 8/3 cotton at 1980 yd/lb (4000m/kg)
12/6 cotton rug warp at 1400 yd/lb (2850m/kg)
"Poppana" $\frac{3}{8}$ " bias-cut fabric strips at 320 yd/lb (640m/kg)
2-ply worsted wool at 5600 yd/lb (11,280m/kg)
Nm 6.5/1 wool singles at 3220 yd/lb (6500m/kg)
Wool singles at 2000 yd/lb (4030m/kg)
Nm 6.5/2 wool at 1580 yd/lb (3200m/kg)
Nm 6/2 wool at 1440 yd/lb (2900m/kg)
Nm 7/2 wool at 1630 yd/lb (3300m/kg)

Product Information Scandinavian Yarn Sources

Most weaving shops stock many of the Scandinavian yarns, or suitable substitutes, used for the projects in this issue. For further assistance in finding Scandinavian weaving yarns, we've listed some suppliers below. Inquire at your local weaving shop about the wholesale distributors (• indicates wholesale only).

C.L. Blomqvist AB, S-510 20, Fritsla, Sweden.

Eaton Yarns, at the Craftskellar, Marymount College, Tarrytown, NY 10591.

Euroflax, Inc., P.O. Box 241, Rye, NY 10580.

Frederick J. Fawcett, 1304 Scott St., Petaluma, CA 94952.

•**Glimåkra Looms 'n Yarns, Borgs Yarn**, 1304 Scott St., Petaluma, CA 94952.

Halcyon Yarn, 12 School St., Bath, ME 04530.

Louise Heite, P.O. Box 53, Camden, DE 19934.

Scancraft, Bergå, P.O. Box 215, Oakton, VA 22124.

Schoolhouse Yarns, 25495 S.E. Hoffmeister Rd., Boring, OR 97009.

•**School Products, Inc.**, 1201 Broadway, New York, NY 10001.

The Unique, 21½ E. Bijou, Colorado Springs, CO 80903.

•**Gerald H. Whitaker, Inc.**, P.O. Box 305, Niagara Falls, NY 14305.

The Wool Gallery, Bergå Yarns, 1555 Fir S., Salem, OR 97302.

Errata

May/June 1986, "Summer and Winter Kitchen Towels", page 65, instructions I-13: the yardage for Natural #108 should be 231 yards.

What's Nm doing in front of the yarn number?

Yarns with "Nm" in front of their yarn count numbers are from Scandinavian countries using a yarn numbering system called Metric Numbering (Number metrical). The number states the number of meters in one gram: the larger the number, the finer the yarn. The Nm yarn count is calculated by dividing a length of yarn by its weight—130 meters of yarn weighing 6½ grams is Nm 20. If this yarn is made up of two plies, it is designated Nm 20/2.

Display Towel

designed by Astrid Sonesson and carried out by Hanna Johansson for Väv Magasinet page 43 10-pattern drawloom

PROJECT NOTES: The one thing that remains today from the old-time Swedish custom of "decking out" the home with cornices, hangings and other handwoven finery is the display hand towel. It is a beautiful length of fabric with rich, decorative patterning that we hang up to hide the kitchen hand towels.

If you are weaving with a shaft drawloom this would be a good pattern to put on as a long warp. The warp is neutral and the weave structure is versatile; you have many possibilities for variation.

FABRIC DESCRIPTION: Upphamta woven with shaft-draw system or with weaving sword.

FINISHED DIMENSIONS: 25¼" wide by 34¾" long, plus hems, heading, and 6¾" ruffle.

WARP: 16/2 cotton at 6336 yd/lb. This is Borgs' 16/2 Bomullsgarn from Glimakra Looms 'n Yarns, available as 3500-yd/250-g tubes: 2600 yd #0000 unbleached.

WEFT: Tabby—16/2 cotton, same as warp: 1970 yd unbleached (some used doubled for pattern weft).

Pattern—16/2 cotton, same as warp but doubled: unbleached and 181 yd #0272 gray-blue.

NOTIONS: Off-white sewing thread.

E.P.I.: 40, in a 20-dent reed.

WIDTH IN REED: 27½".

TOTAL WARP ENDS: 1100.

WARP LENGTH: 2¼ yd, which includes take-up, shrinkage, and 27" loom waste.

DRAFT:

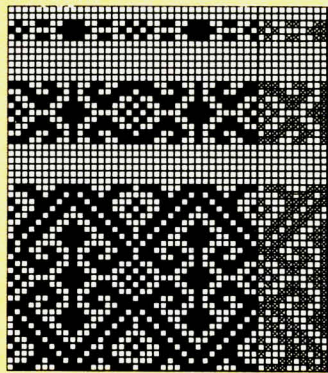

PROFILE DRAFT

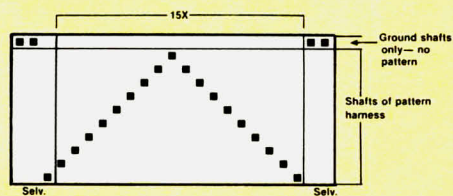

■ = unit of 4 warp threads, threaded to same shaft in the pattern harness and to plain weave or straight twill in the ground harness. In treadling, ■ = 3 picks of doubled pattern weft and 3 picks of tabby.

P.P.I.: 36 background.

TAKE-UP & SHRINKAGE: 10% in width and length.

WEAVING: Ad lib, weave plain weave for lower hem, a narrow unbleached band, plain weave, broad blue border (ca 3"), plain weave, medium blue border (ca 1"), then alternately plain weave (ca 1¼") and narrow unbleached bands for body of towel to desired length, plain weave for header and upper ruffle. For the medium blue border and the narrow unbleached band on the ruffle, draw the *reverse* of the former draws (so that the borders will match when the ruffle is folded over). After the reversed blue border, plain weave, and reversed narrow band, end with plain weave for hem. (For a final finished length of about 35" after shrinkage, hemming, and folding, weave a total of 50".)

FINISHING & ASSEMBLY: Fold and sew each hem in the appropriate direction. To make the ruffle, fold the hemmed top 6¾" to the right side and machine stitch the fold, allowing enough space for the rod. Machine wash, dry, and press.

Upphamta woven with a weaving sword:

If you don't have a shaft drawloom you

UPPHAMTA WITH A SWORD

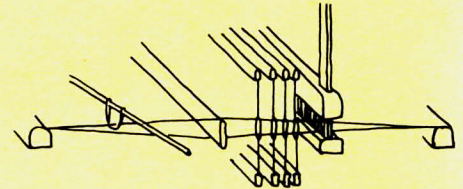
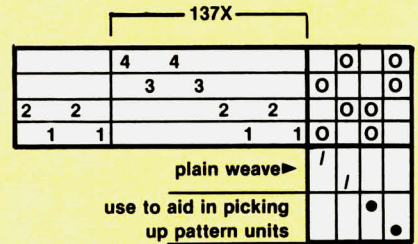

can weave this pattern on four shafts using a weaving sword. Thread the warp in four-thread units of plain weave as shown (see the draft) so that it's easier to pick up the pattern. The small pattern stripes that repeat can be threaded on heddle rods (see illustration). □

Overshot Version

designed by Carol Strickler

DRAFT FOR OVERSHOT VERSION

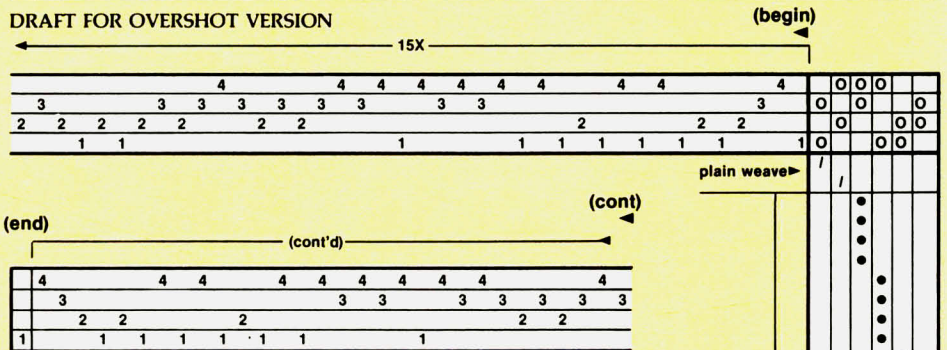

NOTE: For medium blue border and for narrow bands, use select central parts of broad border repeat.

/ = fine tabby weft
• = doubled pattern weft

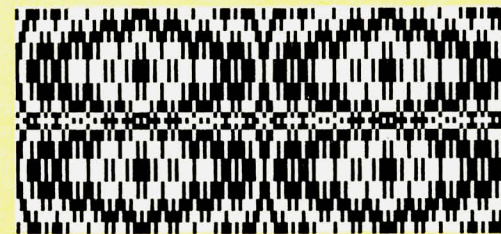

A weaver with only a four-shaft loom and no desire to weave upphamta with sword or heddle rods could use this overshot draft to weave a display towel of similar design.

If this draft is used, 15 repeats + 1 end = 1051 threads. At 40 e.p.i., that is 26¼" wide in the reed. A sett of 40 e.p.i. for 16/2 cotton is very dense; you might prefer to use only 10 repeats + 1 end = 701 threads at 30 e.p.i. (23½" wide) for a more balanced fabric.

The computer drawdown of this overshot pattern was generated on an Apple II+ computer using the "Weft-Writer" program by Stewart Strickler. □

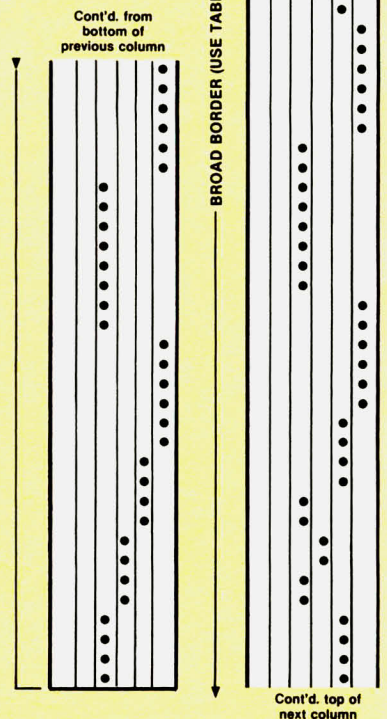

Display Towel



Rag Table Runner

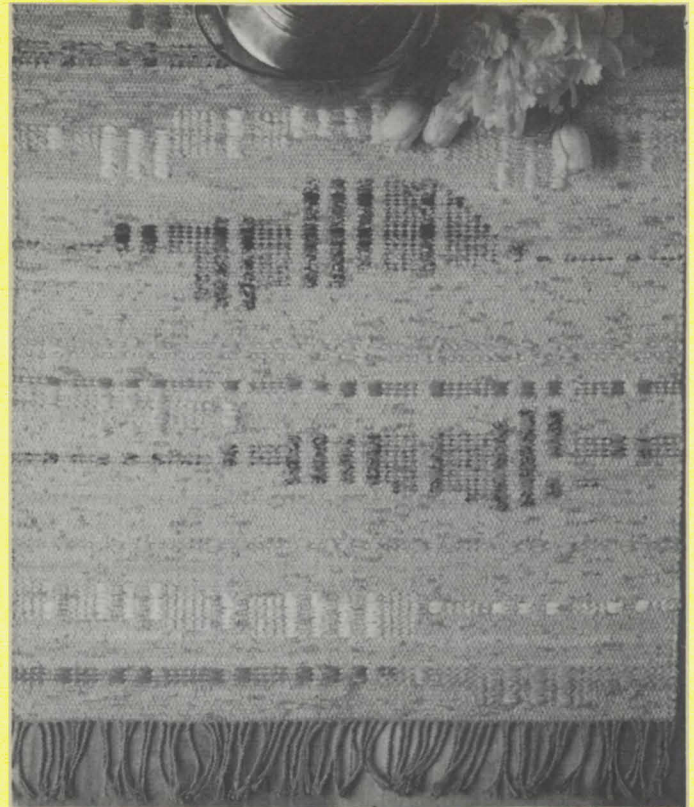

Rag Table Runner

designed by Inga Krook
page 39

4

PROJECT NOTES: This monk's belt variation gives an irregular pattern. The wide runner is woven right side up, with some areas of plain weave, some bands of pattern all across the weave, and some freeform patterns designed as weaving progresses.

FABRIC DESCRIPTION: Plain weave with bands and freeform designs in monk's belt variation.

FINISHED DIMENSIONS: 23" wide by 57" long, plus 3" twisted fringe on each end.

WARP: 8/2 linen at 1200 yd/lb: 1100 yd unbleached (some used for extra fringe). (This is Borgs' Lingarn 8/2, from Glimakra Looms 'n Yarns: Oblekt.)

WEFT: Cotton and cotton/polyester cloth cut in strips 1/2" to 3/4" wide (depending on fabric weight – narrower strips from heavier fabric: 400 yd for the plain weave and 30-40 yd each of seven colors for the pattern. (These are beige/orange print for the plain weave, and pattern colors pale yellow, medium yellow, light blue, medium blue, mottled lilac, pink/lilac print, and multicolored print.)

E.P.I.: 12.

WIDTH IN REED: 25 1/2".

TOTAL WARP ENDS: 306 (302 plus doubled floating selvedge thread on each side).

DRAFT:

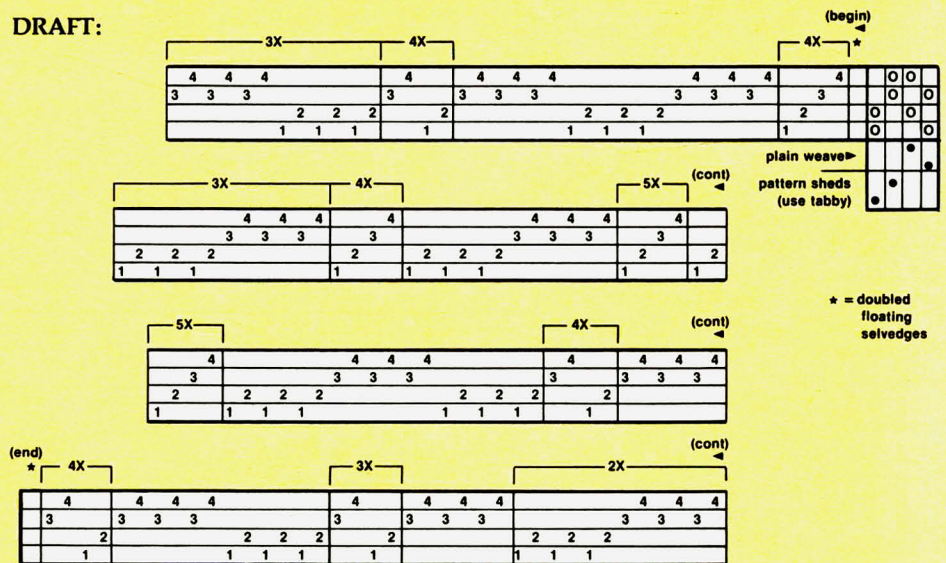

WARP LENGTH: 3 yd, which includes take-up, shrinkage, and 27" loom waste.

P.P.I.: 7 in plain weave, 10 pattern and tabby combined in patterned areas.

TAKE-UP & SHRINKAGE: 10% in width and length.

WEAVING: Leave at least 6" of warp unwoven as fringe at each end. Begin and end runner with 3 picks of plain weave using the warp yarn as weft. Weave the cloth strips in bands of plain weave and bands of pattern inlaid in pattern shed as desired, using plain weave after each pick. (When weaving a freeform design where the pat-

tern weft does not go all the way to the selvage, drop the pattern strip to the wrong side at the end of each pick so that the turns are on the back of the runner. Keep the turns short and neat.)

FINISHING: To make the fringe, add two doubled 12" lengths of warp yarn to the first four warp ends; by hand, divide these strands in two groups and overtwist them, then ply them together with an opposite turning. Knot the twisted group 2" from the fell and trim to 3". Repeat with each group of four warps. □

"Blue Chest of Drawers" Hanging

designed by Kerstin Åsling-Sundberg
page 37



PROJECT NOTES: This large wall-hanging is a lively representation of a traditional blue-painted chest of drawers with orange floral folk pattern and black knobs. The scale of the design gives the piece impact at a distance, yet the multicolored fine threads and subtle details give it great interest at a close-up view.

FABRIC DESCRIPTION: Monk's Belt and plain weave.

FINISHED DIMENSIONS: 51" wide by 76" long.

WARP: Cottolin at ca 3170 yd/lb: twelve colors, used two colors together as doubled thread. (This is Borgs' Bomullin Nm 22/2, from Glimakra Looms 'n Yarns: #0269 yellow, #0238 golden, #0287 orange, #0311 dark orange, #0260 red, #0251 dusky rose, #0283 pink, #0275 pale lavender, #0295 blue, #0313 yellow-green, #0320 light green, #0299 turquoise.)

WEFT: Ground—Nm 7/2 wool at 1550 yd/lb: medium blue, used double. (This is Marks Malsakra Pladgarn, from Gustaf Werner AB. You could substitute Borgs' Nm 6.5/2 wool SN 2-garn at ca 1580 yd/lb: #0036 gray-blue.)

Pattern—Nm 16/2 and 8/1 and 16/1 linens: mixed pinks (ca 4 or 5 strands), oranges (ca 6 or 7), medium blues (4 or 5), and deep purples/blacks (ca 6 or 7). (These are a Swedish linen. You could use Borgs Lingarn Nm 16/2, Lintow Nm 8/1, and Lingarn Nm 16/1 wet spun linens in your mixtures.)

E.P.I.: 10 (2 ends used as one, for a total of 20 ends per inch). **Note:** Colors are paired in the warp. To keep the pairs from twisting together, you can thread each pair in two separate heddles on the same shaft but sley together as though they were a doubled thread. The colors are paired randomly, such as:

- red/golden
- yellow-green/orange
- light green/blue
- blue/orange
- dark orange/light green
- pink/blue
- light green/orange
- dusky rose/blue
- golden/light green
- dusky rose/blue
- light green/pink
- blue/golden
- yellow/turquoise
- etc.

The pairings of warm/warm, warm/cool, and cool/cool colors contribute to subtle vertical striping of the fabric.

WIDTH IN REED: 54½".

TOTAL WARP ENDS: 1092 (546 pairs).

P.P.I.: 10 ground and 10 pattern.

TAKE-UP & SHRINKAGE: 6% in width and ca 10% in length.

WEAVING: The hanging is woven face down, so that the pattern-weft turns are on the top of the web. All pattern wefts reverse at the inner edge of the border so that the border is plain weave.

Using doubled blue wool, weave 15½" plain weave for the bottom hem (doubled blue is used as tabby throughout the piece). Using four strands of pink linens as pattern weft, "A" is woven once for the "drawer bottom". Using four strands of medium blue linens, "B" is woven for 4" for the

8-SHAFT DRAFT:

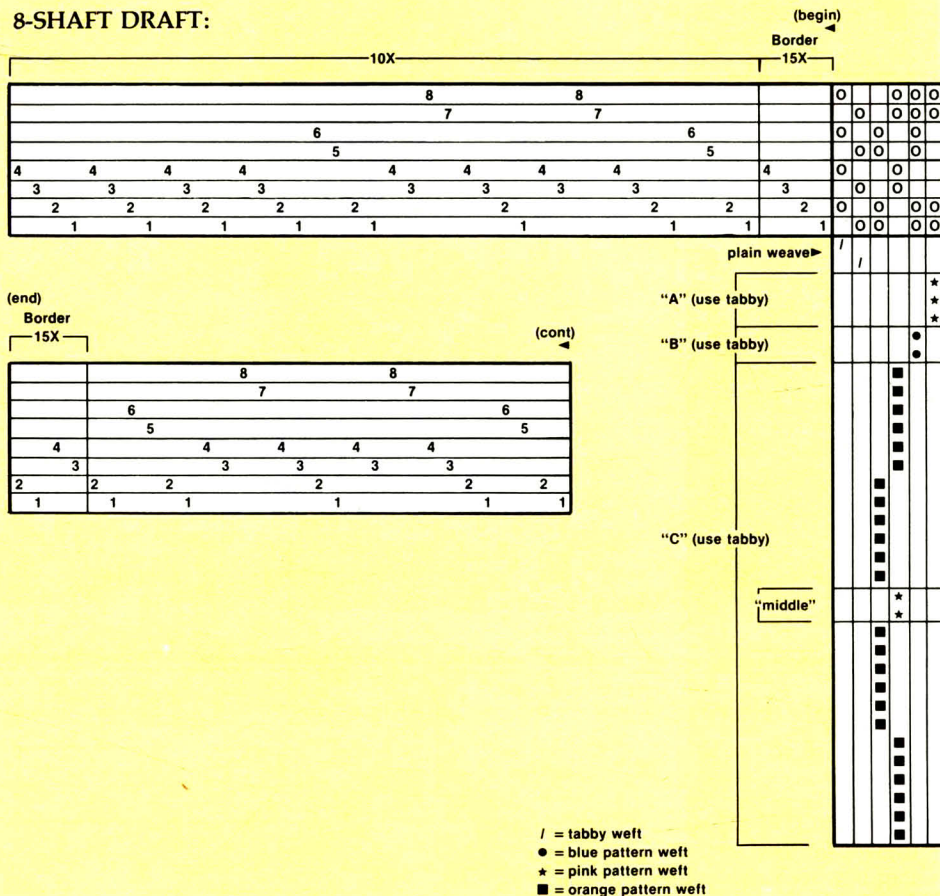

4-SHAFT ALTERNATE DRAFT:

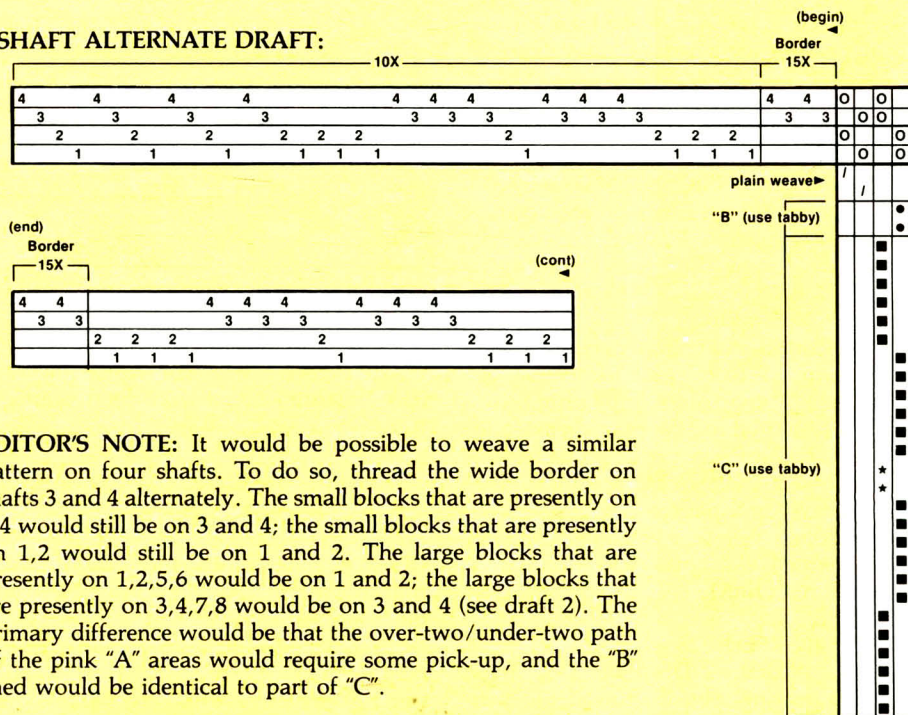

EDITOR'S NOTE: It would be possible to weave a similar pattern on four shafts. To do so, thread the wide border on shafts 3 and 4 alternately. The small blocks that are presently on 3,4 would still be on 3 and 4; the small blocks that are presently on 1,2 would still be on 1 and 2. The large blocks that are presently on 1,2,5,6 would be on 1 and 2; the large blocks that are presently on 3,4,7,8 would be on 3 and 4 (see draft 2). The primary difference would be that the over-two/under-two path of the pink "A" areas would require some pick-up, and the "B" shed would be identical to part of "C".

"drawer front". For the "floral trim", ca 6 strands of orange linens (darker mixture) is used to weave "C", with pink mixture substituted for the orange in the two "middle" picks. To weave the "knob", a 6-strand black/purple mixture is inlaid into only the large blocks of pattern only in the center motif, and the oranges and pinks are carried across that motif on the back (top) of the fabric. The "drawer top" is finished with "A" in blue linen, plus two picks of dark blue or black plain weave the width of the drawer for shadow.

For successive "drawers", 2" of plain weave is woven, then pink "A", blue "B", orange floral with black knob, blue rim, and black shadow. With each drawer, the pink and orange mixtures are changed toward lighter tints. The second, third, and fourth drawers are the same height as the first; the top drawer is deepened by repeating the blue "B" to 26". The weaving ends with 12" plain weave for top hem.

There are other subtle details (such as omission of knob centers, addition of pink inlay under the top drawer knob, etc.) that contribute to the rich interest of this piece. **FINISHING:** Deep hems are made at top and bottom by turning under 1" and then turning under so that that folded edge meets the pattern. A wood bar is inserted in the top, with two screw eyes for hanging, and a steel rod is inserted in the bottom hem for weight. □

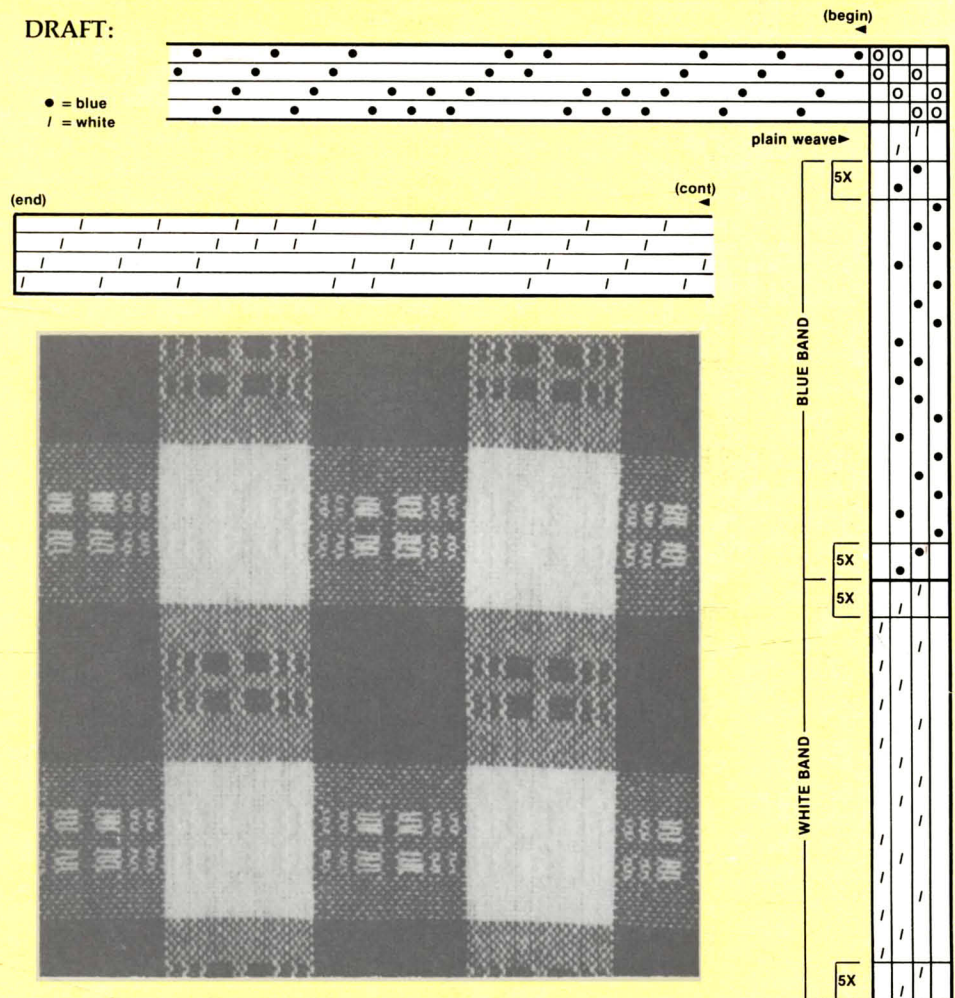
DRAFT:

Heritage Tablecloth

designed by Margaretha Essen-Hedin
page 41

4

PROJECT NOTES: As often as I can take a day off from my weaving, I spend the day at Varmlands Museum in Karlstad, where I gain inspiration from a file of handwoven swatches collected in our province in the '20s and '30s. This is my version of a very fine (64 e.p.i.) cotton piece, possibly originally a dress fabric, probably woven by Lovisa Andersson over 50 years ago in a village north of Karlstad. I have used heavier threads to weave this country-style tablecloth, with respect for the women of the past who have left this heritage to us weavers of today.

FABRIC DESCRIPTION: Monk's belt and plain weave.

FINISHED DIMENSIONS: 38" wide by 38" long, including $\frac{3}{8}$ " hem on each end.

WARP & WEFT: 22/2 cottolin at 3172 yd/lb. This is Borgs' Bomullin Nm 22/2 from Glimakra Looms 'n Yarns, available as 1744-yd/250-g tubes: 1765 yd #0286 medium blue and 1688 yd #0020 bleached white.

NOTIONS: Matching blue sewing thread.
E.P.I.: 22½ (sleyed 1,2 in a 15-dent reed).

WIDTH IN REED: 43¼".

WARP LENGTH: 2 yd, which includes take-up, shrinkage, and 27" loom waste.

WARP COLOR ORDER:

	13 X		
blue	36	36	=504
white	36		=468

TOTAL WARP ENDS=972

P.P.I.: 22½.

TAKE-UP & SHRINKAGE: 12% in width and length.

WEAVING: Using white weft, weave $\frac{3}{4}$ " plain weave for hem. Weave complete repeat 13½ times, beginning and ending with blue band. With white, weave $\frac{3}{4}$ " plain weave for other hem.

FINISHING: Machine stitch ends to prevent fraying. Turn each end under $\frac{3}{8}$ " twice so that no white shows on the front; hand stitch. Machine wash on short gentle cycle; iron while still damp. □

Inspired Bedspread

designed by Anne-Mette Holm
page 49 & cover

4 2

PROJECT NOTES: A milk garland, on which the pail would rest on the milkmaid's head, is now a thing of the past. But I find the carefully chosen harmony of colored scraps in an old, faded and frayed garland to be an inspiration for my bedspread banded in many colors.

FABRIC DESCRIPTION: Weft-faced plain weave.

FINISHED DIMENSIONS: ca 55" wide by 92" long, including a 1½" hem at each end.

WARP: Cotton 20/2 at ca 7940 yd/lb, used

doubled: 5550 yd unbleached. (This is Borgs' Bomullsgarn 20/2, from Glimakra Looms 'n Yarns: Oblekt.)

WEFT: Nm 6/1 wool at 2980 yd/lb: ca 11,500 to 12,000 yd total, of 12 colors. (These are similar to Borgs' Nm 6.5/1 Lundagarn at ca 3220 yd/lb: #0007 black, #0481 light tan, #0848 light gray-blue, #0035 warm brown, #0004 blue-green, #0487 dark gray-blue, #0485 deep blue-black, #0472 red, #0036 light brown, #0099 dark olive, #0845 dark purple, and #0844 hot pink.) Approximately 115 yd of weft are needed for each inch of weaving, so narrow bands require ca 60 yd, 3" bands require ca 350 yd each, and the wide

borders need ca 2000-3000 yd each.

E.P.I.: 22 (11 doubled ends per inch; 2 tripled ends at each selvage).

WIDTH IN REED: 59¾".

TOTAL WARP ENDS: 1316 (656 ends doubled in heddles and reed; 2 tripled at each selvage).

WARP LENGTH: 4 yd, which includes take-up, shrinkage, and 27" loom waste.

DRAFT:

P.P.I.: 60.

TAKE-UP & SHRINKAGE:

ca 8% in width and estimated 4% in length.

WEAVING: Use a temple to keep the web stretched, and "bubble" the weft as necessary to prevent draw-in. Weave a wide border of black, as desired for 14"-24" (including 3" for hem). Weave 3" bands of colors, interspersed with occasional narrow ½" bands. This sequence is:

(Begin)

3" light tan	3" light gray-blue
3" light gray-blue	3" light tan
½" warm brown	3" blue-green
3" light tan	½" dark olive
3" blue-green	3" light tan
3" light tan	3" dark gray-blue
3" dark gray-blue	3" dark purple
3" deep blue-black	3" light gray-blue
3" light gray-blue	3" light tan
½" red	3" blue-green
3" light tan	3" light tan
3" blue-green	3" dark gray-blue
3" light tan	½" hot pink
3" dark gray-blue	3" light tan
3" light brown	End with a wide border of black

(Continue top of next column)

FINISHING: Machine stitch ends to help prevent fraying. Turn under twice for a 1½" hem at each end, and use a doubled strand of black border weft yarn to sew the hems by hand. □

Wool Shawl

designed by Kim Naver

page 51

4 2

PROJECT NOTES: Fine wool worsted is used in plain weave to create this soft, lightweight shawl. On a longer warp the 1½" stripes could be crossed with different weft color sequences for a variety of different shawls from the one warp. Tracking gives the simple fabric the appearance of subtle pattern.

FABRIC DESCRIPTION: Plain weave.

FINISHED DIMENSIONS: 19½" wide by 72" long, plus 2" fringe on each end.

WARP & WEFT: Fine wool worsted 2-ply at 5600 yd/lb: 1250 yd black and 1300 yd white. (These are Oregon Worsted's Willa-

mette 20/2, from Halcyon Yarn: #5 black and #2 white.)

E.P.I.: 20.

WIDTH IN REED: 21½".

TOTAL WARP ENDS: 432.

WARP LENGTH: 3¼ yd, which includes take-up, shrinkage, and 27" loom waste.

WARP COLOR ORDER:

	6x			
black	8	32	8	=208
white	32	32		=224
				TOTAL ENDS=432

DRAFT:

P.P.I.: 20.

TAKE-UP &

SHRINKAGE:

10% in width and length.

WEAVING: Leave at least 4" of unwoven warp at each end for fringe. Weave 17 picks of black and 3 picks of white alternately for 39½", ending with the black; then weave 17 picks of white and 3 picks of black alternately for 39½", ending with the white.

FINISHING: At each end of the shawl, knot the fringe in groups of 10 or 11 ends (three knots per stripe), using an overhand knot tightened against the woven end. Trim fringe to 2".

Hand wash the shawl in warm water with suitable soap; rinse; hand block flat to dry. □

Black & White Rug

designed by Jette Kai

page 50

4 2

PROJECT NOTES: This heavy linen, jute, sisal, and wool rug is inspired by Egyptian chevron patterns. Weaving it requires a strong heavy loom.

FABRIC DESCRIPTION: Weft-faced plain weave tapestry.

FINISHED DIMENSIONS: 38¼" wide by 75" long.

WARP: Linen Nm 8/5 rug warp at ca 470 yd/lb; 750 yd natural. (This is Borgs' Nm 8/5 Linnemattvarp, from Glimakra Looms 'n Yarns, available as ca 250-gr tubes: Oblekt.)

WEFT: The black is a mixture, five strands of four yarns used together: two strands of Nm 4/1 linen at ca 1440 yd/lb, and one strand each of Nm 4/2 jute, Nm 16/2 linen at ca 2580 yd/lb, and Nm 6/2 rug wool (all of them black). The white is a mixture, three strands of two yarns used together: two strands of Nm 4/1 linen at ca 1440 yd/lb (unbleached), and one strand of sisal at ca 300 yd/lb (unbleached). The red is a mixture, one strand each of two yarns used together: sisal at ca 300 yd/lb, and Nm 6/2 rug wool (both rosy red). You could substitute comparable harsh yarns.

E.P.I.: 5.

WIDTH IN REED: 40".

TOTAL WARP ENDS: 204 (including 2 sets of doubled ends at each side).

WARP LENGTH: 3½ yd, which includes take-up, shrinkage, and 27" loom waste.

DRAFT:

P.P.I.: 15.

TAKE-UP &

SHRINKAGE:

ca 4% in width and estimated 2% in length.

WEAVING: Leave at least 6" of warp as unwoven fringe for later finishing. Treadling plain weave, weave black for 2½" band, then red for ¾" band. Following the diagram, weave the body of the rug for approximately 70" in black and white tapestry. (Note that the weft junctions move

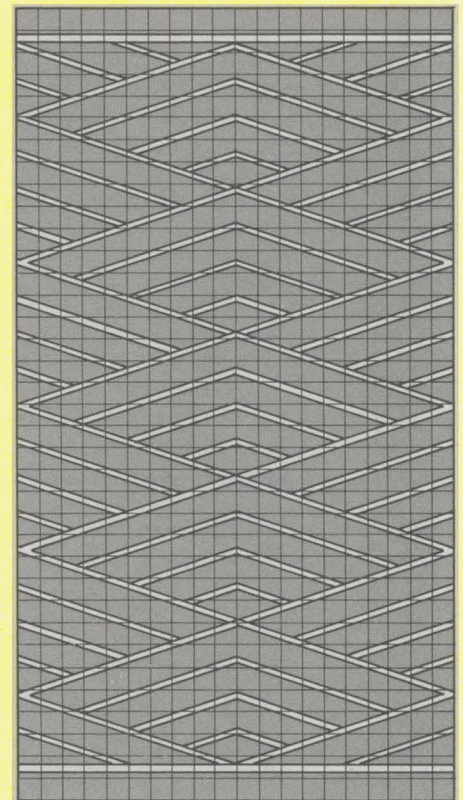

right or left by two warp threads each time, so once the pattern is started correctly it can be woven by counting.) End with another ¾" band of red and a 2½" band of black. Leave at least 6" of warp as unwoven fringe for finishing.

FINISHING: Make a weft-protecting Woven Edge finish using 9 warp ends, beginning at one corner (for explicit instructions, see Collingwood's *Techniques of Rug Weaving* or *Finishes in the Ethnic Tradition* by Baizerman & Searle). Starting at one corner makes a slight diagonal end at one side and a tail of ends to braid together at the other side.

This rug is firm and heavy as it comes off the loom, and it needs no blocking. □

Tin & Tapestry Hanging

designed by Elisabeth La Cour
page 48

4 2

PROJECT NOTES: In this hanging, lines and rectangular solid areas of tapestry contrast with open areas of unwoven warp. Sparkle is added to the tapestry blocks by freeform pieces of melted and hardened tin attached with silver thread.

FABRIC DESCRIPTION: Weft-faced tapestry and unwoven warp.

FINISHED DIMENSIONS: Ca 18½" wide by 37" long, including a 1½" hem at each end.

WARP: Five strands of three yarns (three strands of ca 20/2 wool, one strand of ca 10/2 cotton, and one strand of ca Nm 16/2 linen; all unbleached or natural), handplied at ca 1½ twists/in, Z-ply.

WEFT: A variety of thick yarns (such as rug wool) and stranded yarns (such as the warp group, and other similar linen and wool mixtures), in black, white/natural, pale silvery gray, and three blues.

E.P.I.: 5.

WIDTH IN REED: 20".

TOTAL WARP ENDS: 100.

DRAFT:

WEAVING & FINISHING:

Black wool is woven for 3½" at each end, to be

folded and hemmed to the front over wood sticks at both ends. Shaped areas and wedges with black outlines are woven in Gobelin tapestry technique in the solid rectangles. Occasionally a 2-, 3-, or 4-pick line of black is woven in a meandering path across the entire width of the warp. Metallic silver thread is used to hand stitch the freeform melted and hardened tin embellishments to the face of each tapestry area. □

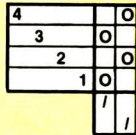

Rose Jacket

designed by Åse Blake
page 56

8

PROJECT NOTES: Two 4-shaft twills are combined in this warp threading, making it possible to weave straight twill in the solid-color area and point twill in the pattern stripe. The yarns used result in a lovely soft garment.

FABRIC DESCRIPTION: 8-shaft 2/2 twills.

SIZE: Women's medium. Circumference at hem and bust 43". Length from shoulder 24". Sleeve length from center back 21½". (When designing the garment, plan on a finished circumference of hip measurement plus about 2" ease.)

WARP & WEFT: Nm 6.5/2 wool at 1580 yd/lb; 1750 yd rose (some used for weft),

Rose Jacket



85 yd lavender, 55 yd pink, and 25 yd light red. These are Borgs SN 2-garn Nm 6.5/2, from Glimakra Looms 'n Yarns: #0049 rose, #0048 light lavender, #0055 pale pink, and #0056 light red.

DRAFT: Editor's Note—A similar fabric can be woven on four shafts by moving the

point twills from 5-8 down to the corresponding first four shafts and turning around some of the straight twill sections to "echo" the colored stripes (see draft). The result will be vertical herringbone rather than straight twill in the solid-color parts of the jacket.

8-SHAFT VERSION

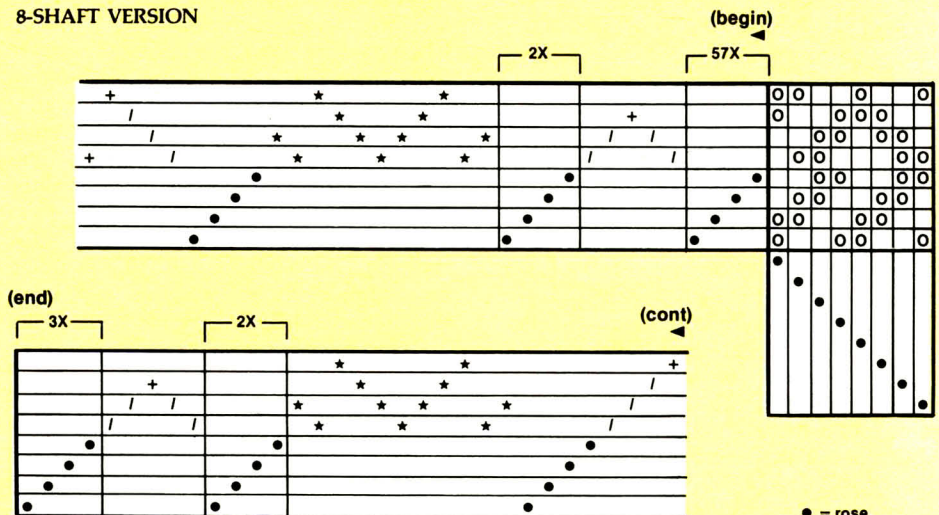

4-SHAFT VERSION

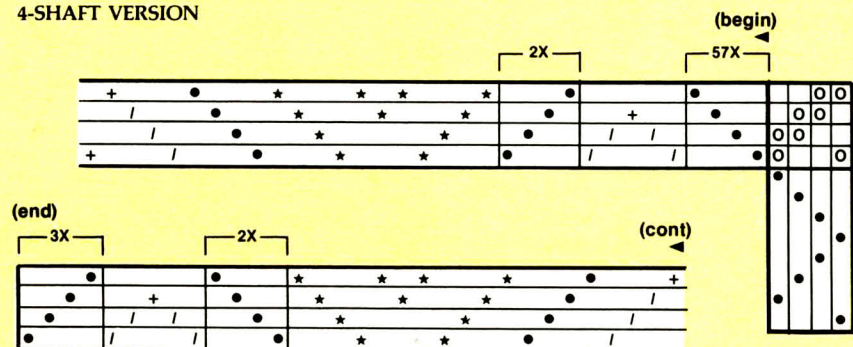

NOTIONS: Matching rose sewing thread, 1" seam binding (commercial or hand-made), pewter clasp or other suitable closure.

E.P.I.: 12.

WIDTH IN REED: 25½".

WARP LENGTH: 3½ yd, which includes take-up, shrinkage, and 27" loom waste.

WARP COLOR ORDER:

Start ▶				
rose	12	8	4	4
pink	2	2	3	3
light red	1		3	
lavender		11		
Cont. ▶				
rose		8	228	= 264
pink		2	2	= 14
light red		1		= 5
lavender		11		= 22
TOTAL WARP ENDS = 305				

P.P.I.: 10.

TAKE-UP & SHRINKAGE: ca 15% in width and 8% in length.

WEAVING: Follow the treadling sequence, beating evenly (web will draw in about 10%). Weave at least 90" under relaxed tension (to allow for shrinkage). Hemstitch both ends while still on loom.

FINISHING: Hand wash in mild soap and warm water. Rinse thoroughly three times. Spin the fabric in the washer for about 15 seconds to remove excess water. Line dry. Steam press lightly using "Iron All" or similar Teflon cover for iron, or use a pressing cloth.

ASSEMBLY: Measure two lengths of fabric 41" each. Machine stitch and zigzag both ends of each length before cutting apart. Lay the two pieces side by side, pattern stripes to the outer sides. Make sure that both are wrong-face-up (as face and back of this fabric differ), and mark face of each piece with a pin. Stay stitch, cut, fold, and seam the garment according to the diagram. (If adjustments have been made in the fabric width, be sure to adjust the sleeve cut to be half the actual width of the fabric. Remember to machine stay stitch on both sides of the crosswise cut line before cutting.) On each half, fold the top part down to form the sleeve, and fold the lower part in to form the front. Seam these together, right sides together, with about a ¾" seam allowance; press seam open and hand stitch seam binding over the seam on the inside. Hand stitch the two halves together at the back, from bottom to 5½" below shoulder fold, using a washed piece of the rose weft yarn to sew a figure-8 through selvedge weft turns of the two pieces. Reinforce the top end of this flat seam with an arrowhead tack, using the same rose yarn. Try on the garment, and turn under and pin a hem at the desired length. (Hemline may need to curve to make front and back ca 1" longer than underarms, for straighter drape on body.)

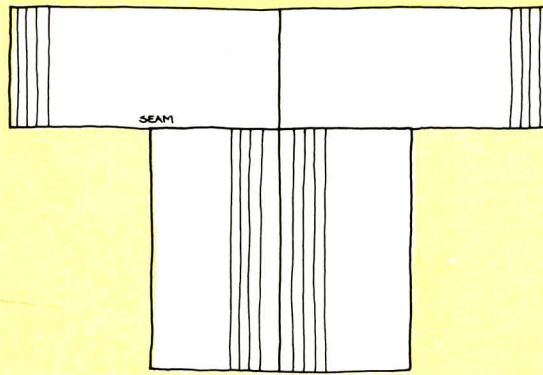

Lightly press the hemline in place, and use that as a guide to pin on the seam binding, right sides together, about 1" from pressed line. Sew on seam binding with a straight line. Sew on seam binding with a straight line. Sew on seam binding with a straight line. Reinforce with zigzag stitch next to that seam. Trim away excess woven fabric beyond the zigzagging, turn up the hem, and hand stitch in place. Sew on a clasp at the seam juncture in the front. □

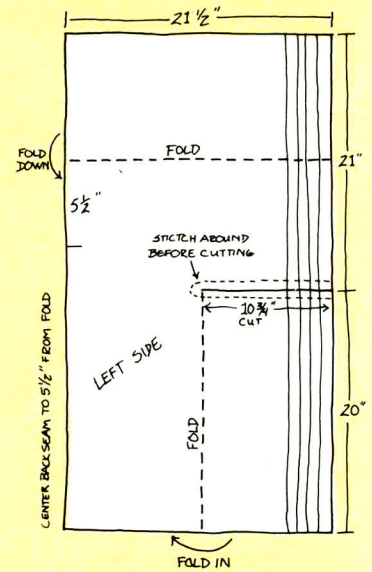

Right side is mirror image of left side.

Lenten Pulpit Antependium

designed by Mary Temple
page 57

4

PROJECT NOTES: This pulpit antependium is one of a set of paraments made for the Shepherd of the Valley Lutheran Church in Lakeland, Minnesota. There are four pieces in the set: a minister's stole, a stole for the cross, a large cloth for the altar or communion table, and the pulpit antependium described here. The set was woven on four coordinated warps: two for the altar cloth, one for the two stoles worked side by side to match, and one for the pulpit piece. Since both the standing cross and, often, the minister are behind the altar, the design elements on the stoles are placed to be above altar level so they will not be hidden.

The antependium is weighted to hold it in a small groove in the top of the pulpit or lectern. There is also a long brass rod

weight for the back hem of the altar cloth to hold it firmly in place.

Editor's Note: Since the designing of paraments for a church involves many individual decisions, we have given here only the basic information about this piece. We've included the fabric specifications, draft, and color blending technique, but no specific yarn amounts or specific weaving instructions.

FABRIC DESCRIPTION: Half-dukagång and inlay on plain weave.

FINISHED DIMENSIONS: 24" wide by 32" long, including headings and hem.

WARP: Singles wool at 2000 yd/lb. This is Singles from Harrisville Designs: Navy, Violet, Aubergine, Plum.

WEFT: Ground—singles wool at 2000 yd/lb (same as warp): Plum. Alternated pick-and-pick with 2-ply wool at 1600 yd/lb. This is Beall Ceronne from Filature Lemieux: Vin #28.

Pattern—2-ply wool. This is Takana-ja

WARP COLOR ORDER: The first two Navy and final 18 Violet warp threads are doubled for selvages and greater visual weight to balance the dukagång effect.

Begin ▶

Navy	31	4	3	2	1										
Violet		1	2	3	4	29	4	3	2	1					
Aubergine							1	2	3	4	29	4	3	2	1
Plum												1	2	3	4

Cont. ▶

Navy																= 41
Violet							1	2	3	4	20					= 79
Aubergine	1	2	3	4	10	4	3	2	1							= 79
Plum	60	4	3	2	1											= 80

TOTAL WARP ENDS = 279

Raanulanka from Schoolhouse Yarns and Eaton Yarns: 3 deep hues of purple, violet and magenta.

NOTIONS: Plum sewing thread, brass rod weights.

E.P.I.: 10.

WIDTH IN REED: 27".

TOTAL WARP ENDS: 279.

DRAFT:

64X								
*	*	*	4		3	*	O	O
	*	*	3		2		O	O
	*	*	2		1		O	O
*	*		1				O	O

WEFT:

- = Vin 2-ply
- X = Plum singles
- = dukagang inlay pattern

WARP: Follow "Warp Color Order".
 * = doubled warp threads of appropriate color

P.P.I.: 10.

TAKE-UP & SHRINKAGE: 10% in width and length.

WEAVING: Pattern areas are half-dukagang inlay in curved bands of three colors

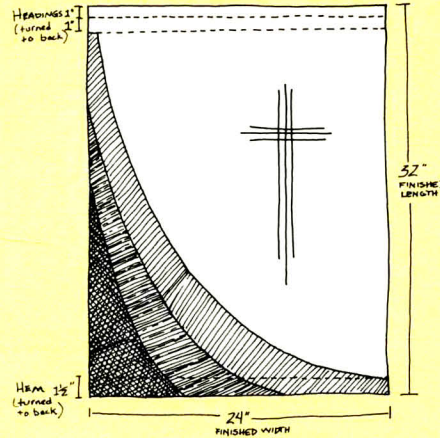

laid into the pattern shed. These inlays are clasped on the back (top side) of the fabric so that color gradation of the face (under side) of the fabric is very smooth. Since the visual mixture of colors is important in the

overall appearance, care is taken to be sure that it is the Plum tabby weft that covers the dukagang tie-down warps throughout the inlay areas.

The shadowed cross in the Plum warp area is formed by discontinuous warp and weft inlays. For the upright, three lengths of heavy maroon wool thread are laid in alongside three of the Plum warps on shaft 1, three threads apart. They are weighted and woven as though they were replacements for broken warps. For the crossarm, three corresponding lengths of the same maroon wool are laid into every fourth plain weave shed alongside the Plum tabby weft. All tails of the wool lengths are brought to the back (top) of the fabric to be worked in later.

FINISHING: All loose warp and weft inlay ends are darned into appropriate sheds on the back of the fabric. Ends are stay-stitched. Fabric is steam pressed. Ends are hemmed, with brass rods enclosed in headings and lower hem for hanging and weighting. □

Bound Rosepath Rug

designed by Phyllis Waggoner
 page 59

PROJECT NOTES: This is a colorful patterned rug woven on a 4-shaft rosepath threading with an unbalanced 3/1 tie-up. The face of the rug is plain weave, but the back is padded by weft skips which are longer in the pattern areas. Color designs "mapped out" on graph paper determine the treadling.

FABRIC DESCRIPTION: Weft-faced 3/1 twill.

FINISHED DIMENSIONS: 24" wide by 43" long.

WARP: 12/6 cotton seine cord at 1407 yd/lb. This is Borgs' Mattvarp Fiskgarn 12/6 from Glimakra Looms 'n Yarns, available as ca 1550-yd/500-g tubes: 580 yd #1263 orange (or #1266 brown), including some used for weft.

WEFT: 2-ply rug wool at ca 900 yd/lb: total estimated ca 1800 yd of rose, burgundy, turquoise, sea blue, tan, beige, mustard, and red-brown. This is a mill end, but you could use a comparable size rug wool. (You can use a coarser wool, such as Borgs' Nm 2.2/2 Frostagarn at 545 yd/lb, or Wilde & Wooly's Subtle Shades 3-ply at 720 yd/lb. If you do, the rug will weave faster at fewer p.p.i. but you may need to adjust other calculations such as e.p.i., dimensions, and yarn yardages accordingly.)

E.P.I.: 8.

WIDTH IN REED: 24½".

TOTAL WARP ENDS: 193 working ends plus doubled floating selvages, 197 total ends.

WARP LENGTH: 2¾ yd, which includes

DRAFT:

+ = doubled floating selvage

24X				a	b	4	3	2	1
	4		4			O	O	O	O
		3		3		O	O	O	O
			2		2		O	O	O
1				1		O	O	O	O

To weave plain weave, alternate treadles a and b

To weave standard boundweave using two, three, or four colors, treadle one shaft down at a time in broken (1,3,2,4) order or in straight (1,2,3,4) order. Use designated color on each pick. Because the four wefts pack down to cover the warp, this treadling is shown as one horizontal row in the draft. Repeat the sequence until squared.

To weave "short cut" boundweave using one or two colors, treadle one shaft, the opposite shaft, and opposite tabby (1,3,a) or (2,4,b) order. Use designated color on each pick. Because the three wefts pack down to cover the warp, this treadling is shown as one horizontal row in the draft. Repeat the sequence until squared.

EXAMPLE (similar to a band of the rug)

	4		4		4		4		4								
etc.		3		2		2		3		2		2		3		3	
	1		1		1		1		1		1		1		1		1

a b 4 3 2 1

	O	O	O	O
O	O	O	O	O
O	O	O	O	O
O	O	O	O	O

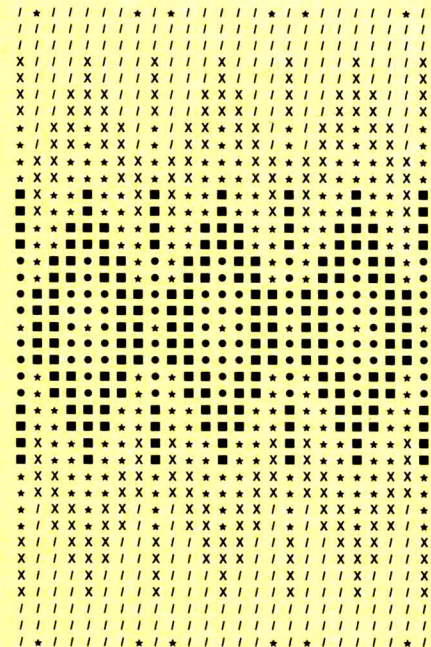

- = purple
- * = turquoise
- = pink
- X = mustard
- | = beige

Remember that each horizontal row of the treadling represents a SEQUENCE of treadles repeated until square, NOT two or more treadles used simultaneously!

take-up, shrinkage, and 27" loom waste.

P.P.I.: ca 50 to 80.

TAKE-UP & SHRINKAGE: 2% in width (if weft is properly bubbled) and 4% in length.

WEAVING: At the beginning and end,

leave 6" of the warp as unwoven fringe, for later finishing. Using warp yarn, weave four picks of plain weave. Using weft wools, weave pattern as desired for 45". End with four picks of plain weave using warp yarn.

FINISHING: After the rug is taken off the loom, work one row of Damascus Edge at each end on the wrong side of the rug (see *Finishes in the Ethnic Tradition* by Baizerman & Searle, or *The Techniques of Rug Weaving* by Collingwood, for instructions). Use a large needle to weave the resulting warp ends back into the rug alongside the warps. The last few warp ends can be braided and ended with an overhand knot for a "tail" at the corner. There are also many weft yarn ends on the back of the rug which must be drawn back into the piece warpwise for at least an inch, using a large needle.

Boundweave with an unbalanced tie-up has long weft floats on the back and weft-faced plain weave on the front, so the rug will curl. To block it, pin the rug face down onto a towel-protected padded surface, and press with a steam iron. Allow to dry for 24 hours before handling. □

Skillbragd Runner

designed by Myrna Golay
page 61

10- or 12-shaft
countermarch

PROJECT NOTES: This technique is known as Skillbragd (pronounced she'll-bragd) in Norway and as Smålandsväv in Sweden.

I have adapted the skillbragd technique to work on a 10- or 12-shaft countermarch loom with string heddles. The two back shafts are used for the plain weave and the front four shafts for the pattern. The shafts in between are not used but provide the space needed between the two sets of shafts. The resulting runner is crisply patterned and firm. It is rustic but gains a gleam of elegance from the linen tabby.

FABRIC DESCRIPTION: Supplementary-weft patterned plain weave.

FINISHED DIMENSIONS: 12" wide by 45" long, including 1/2" hem at each end.

WARP: 22/2 cottolin at 3172 yd/lb. This is Borgs' Bomullin 22/2 from Glimakra Looms 'n Yarns, available as 1750-yd/250-g tubes: 630 yd unbleached #0000.

WEFT: Tabby—20/1 linen at 6000 yd/lb. This is 20/1 wet spun from Frederick J. Fawcett, Inc., available as 3000-yd/8-oz tubes: 408 yd bleached.

Pattern—6/2 wool at 1440 yd/lb. This is Rauma Spaelsaugarn from The Unique in Colorado Springs, available as 316-yd/100-g skein: 392 yd color #622 dark rust.

NOTIONS: Off-white sewing thread.

E.P.I.: 20, in a 10-dent reed.

WIDTH IN REED: 13 3/4".

TOTAL WARP ENDS: 266.

WARP LENGTH: 2 1/4 yd, which includes take-up, shrinkage, and 27" loom waste.

P.P.I.: 40 (20 pattern and 20 tabby).

TAKE-UP & SHRINKAGE: 9% in width and 6% in length.

INCOMPLETE THREADING, WITH COMPLETE TIE-UP AND TREADLING

(This partial threading is an example of how to translate the profile draft to a threading draft. Please see the profile draft for the complete threading.)

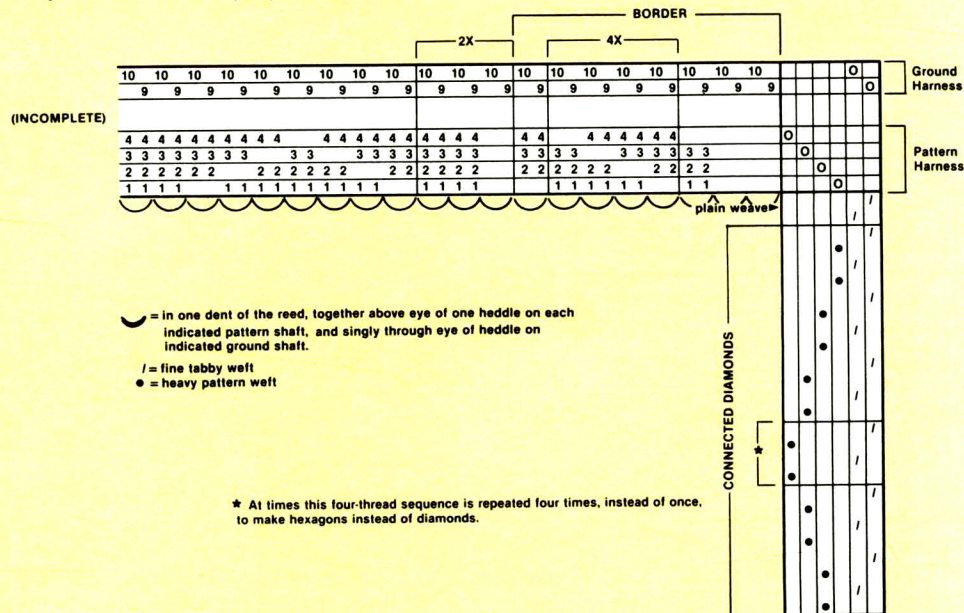

PROFILE DRAFT

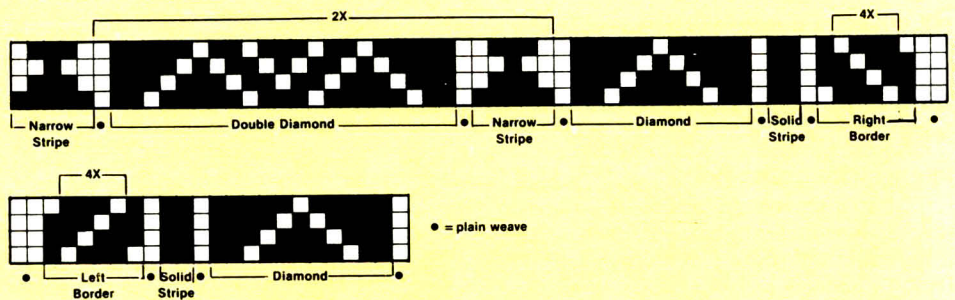

Draft Instructions. Use a 10- or 12-shaft countermarch loom with string heddles, using the two back shafts for the plain weave harness and the front four shafts for the pattern harness.



Each [diagram] column represents a pair of threads which are threaded together above the eye of a heddle on the indicated shaft or shafts of the front harness and divided through the eyes of heddles on shafts 9 and



10 alternately. Thus, [diagram] = a pair on 1-2-4-9 and 1-2-4-10. A blank column means the pair bypass the front harness completely and are threaded only on 9 and 10.

Thread the warps singly through the eyes of the heddles on the back shafts, the first through 9 and the other through 10.

Thread the front pattern shafts in groups of two threads, putting a pair of warps through the open area of the heddle above the eye, not through the eye itself. (The pair of ends may be threaded on one, two, three, four, or none of the front shafts—follow the draft carefully!)

Note: To ensure that the two harnesses of shafts will work independently, there must be no treadle ties for the two ground shafts on any treadles except the two that operate those ground shafts, and those two treadles must have ties only for those ground shafts.

WEAVING: With tabby weft weave 1" plain weave for hem. Following the treadling, weave pattern for 48". End with 1" plain weave for the other hem.

FINISHING: Machine stitch ends to prevent fraying. Turn under twice for a 1/2" hem on each end, leaving four shots of plain weave showing on the front to match the selvages; hem by hand. Hand wash in hot water and dish detergent; rinse well. Roll in a towel to blot; lay flat to dry. When dry, place face down on a padded surface and steam lightly from the back. □

Warp-Patterned Adaptation

designed by Carol Strickler
woven by Ardis Dobrovolny



PROJECT NOTES: This weave is a six-shaft adaptation of the Skillbragd Runner. I have "turned" the draft so that it becomes a supplementary-warp design. The fine ground warps are carried on the first two shafts, and each block of pattern warp is carried on one of the four additional shafts. The pattern itself has been modified slightly to ensure no overly long warp skips, and the fifth block, the areas of pattern which weave solidly for the entire length of the Skillbragd piece, have been eliminated. I have used finer threads, and have chosen 100% cottons for both ground and pattern to minimize the danger of elasticity differences in the warp. Unlike Myrna Golay's runner, this fabric weaves face up.

Turning such a single-warp, two-weft draft makes it become a one-shuttle weave, quick to weave once the loom is warped.

FABRIC DESCRIPTION: Four-block supplementary warp and plain weave.

FINISHED DIMENSIONS: 10" wide by 44½" long, including ½" hem on each end.
WARP: Ground—20/2 mercerized cotton at 8400 yd/lb. This is 20/2 Astra Spun from Usdan Kolmes Industries, available as 8400-yd/1-lb cones: 620 yd #79 natural.

Pattern—8/2 cotton at 3400 yd/lb. This is 8/2 from Usdan Kolmes Industries, available as ca 1-lb tubes: 525 yd medium brown.

WEFT: 8/2 cotton at 3400 yd/lb. This is same as the pattern warp: 337 yd tan.

NOTIONS: Off-white sewing thread.
E.P.I.: 48 (24 ground and 24 pattern) in a 12-dent reed.

WIDTH IN REED: 11".

TOTAL WARP ENDS: 262 ground and 222 pattern.

WARP LENGTH: 2¼ yd, which includes take-up, shrinkage, and 27" loom waste.

WARPING HINT: This warp will wind on (and weave off) easier if it is sleyed and threaded front-to-back. When beaming it, raise the pattern shafts slightly and prop up by slipping a flat shuttle or other strong stick through the raised shafts so that it rests on top of the ground shafts and holds the others up until beaming is completed.

P.P.I.: 20.

TAKE-UP & SHRINKAGE: 9% in width and 7% in length.

WEAVING: All weaving is done with the one weft. There is no true plain weave, but the ground can be woven plain weave with the pattern entirely up, entirely down, or mixed. With all pattern warps down, weave 1" plain weave for hem. Weave 48" pattern (beginning and ending with border if desired). With all pattern warps down,

PROFILE DRAFT

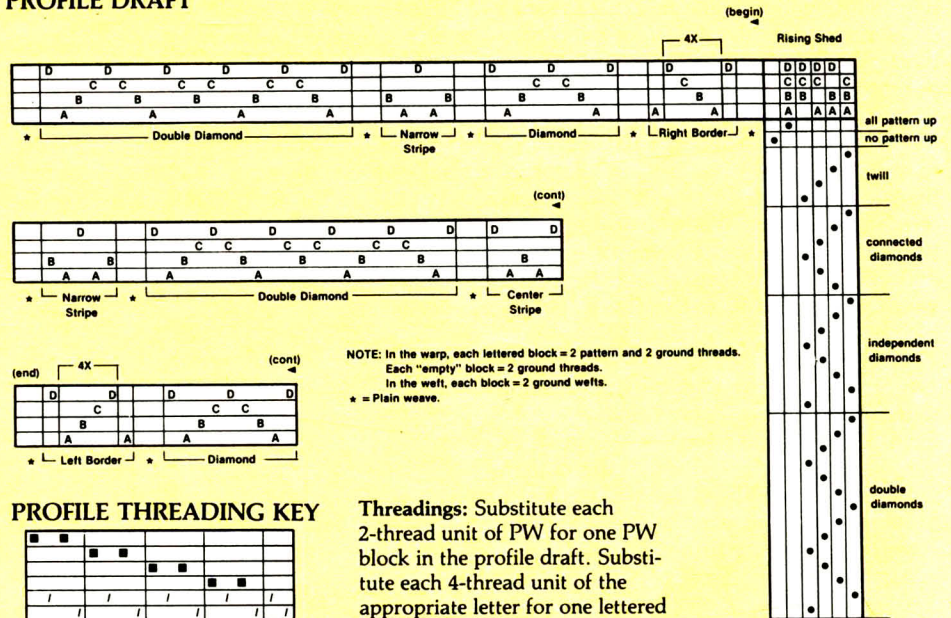

PROFILE THREADING KEY

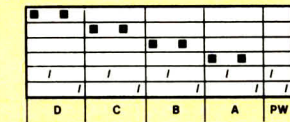

Threadings: Substitute each 2-thread unit of PW for one PW block in the profile draft. Substitute each 4-thread unit of the appropriate letter for one lettered block in the profile draft. Always use the units in the same direction, and do not reverse them.

TIE-UP OPTIONS: If you don't have 12 treadles, tie treadles to 1, to 2, and to each of the five block combinations, and use two treadles at a time.

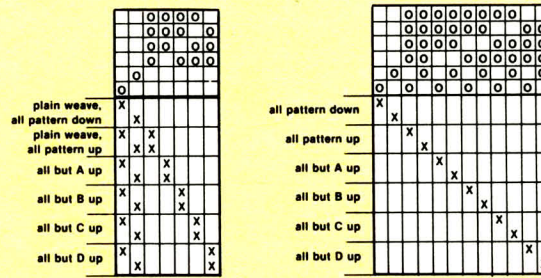

EXAMPLE (threading draft is incomplete)

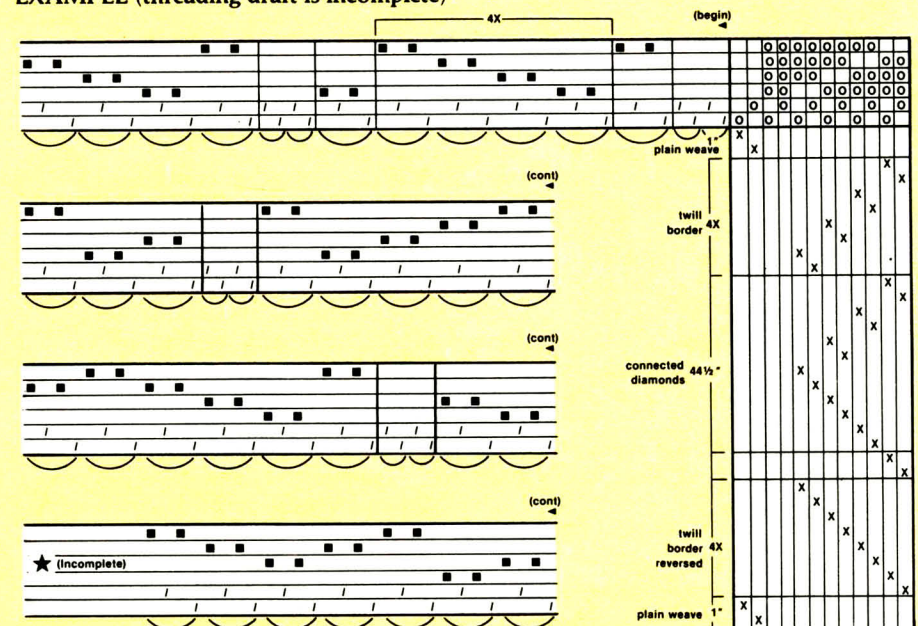

~ = in one dent
/ = ground warp
■ = pattern warp
X = ground weft

☆ Continue threading by substituting units for blocks in the profile draft. Sley each four-thread pattern-and-ground unit in one dent of the reed and each two-thread ground unit in one dent of the reed, as indicated.

weave another 1" plain weave for other hem. Throughout, make sure that the shed is clear, since the density of sley and hard twist of the 20/2 ground warp will encourage threads to cling and shafts to "hang up". Because of the difference in take-up between the ground and pattern warps, it may be necessary to adjust the tension of the pattern warps. To do this raise all pattern shafts, insert a dowel or firm stick under the pattern warps behind the shafts, and slide the dowel to the back beam; weight it if necessary so that it will take up the slack.

FINISHING: Machine stitch ends to prevent fraying. Turn under twice, leaving four shots of plain weave showing on the front to match the selvages. Hand stitch the hem, making sure that all the pattern warp ends on the back are tucked neatly inside it. Machine wash on gentle cycle. Lay flat to dry. Iron firmly, face down. □

Glit Coat

designed by Louise B. Heite
page 65

4

PROJECT NOTES: *Glit* is an Icelandic variant of the Scandinavian embroidery weave *dukaġang*. Icelandic wool makes a warm, light fabric, and this coat is large enough to be worn over other long-sleeved garments.

FABRIC DESCRIPTION: Pattern inlay over plain weave ground.

SIZE: Women's large. Circumference at chest 60". Length from shoulder 37". Sleeve length from center back 25" plus 4" cuffs.

WARP: Singles wool at 2000 yd/lb: 775 yd natural, 575 yd light gray, and 225 yd dark gray. (These are Icelandic wools, from Louise Heite, Importer: #1-001 Natural White, #1-003 Natural Gray, and #1-004 Natural Brown-Black.)

WEFT: **Ground**—2-ply wool at 1150 yd/lb: 1450 yd pale gray. (This is Samband Gefjun Lodband 2-ply #8.)

Border ground—Singles wool, used double: 250 yd dark brown, 200 yd dark gray, 150 yd light brown, 75 yd light gray, and 50 yd bright green. (These are Samband Gefjun Lodband singles #29 and #31, and Alafoss Crystal Fleece singles #202 and #209.)

Pattern—Singles wool, used four strands together: one 50-g skein each of bright green, olive green, pink, magenta, and mustard yellow. (These are Samband Gefjun Lodband singles #45 and #46, and Alafoss Lopi singles #216, #217, and #219.)

(The singles yarns in natural colors are available on ½-lb and 1-lb cones from

Louise Heite, Importer. Dyed colors and plied yarns are available from the same source by special order.

WARP ENDS: 364.

E.P.I.: 10.

WIDTH IN REED: 36".

WARP LENGTH: 4 yd, which includes take-up, shrinkage, and 27" loom waste.

WARP COLOR ORDER: ★ = doubled selvages.

	★	—12×—		★	
natural	2	15			= 182
dark gray		2	2	2	= 50
light gray		11			= 132
TOTAL WARP ENDS = 364					

DRAFT:

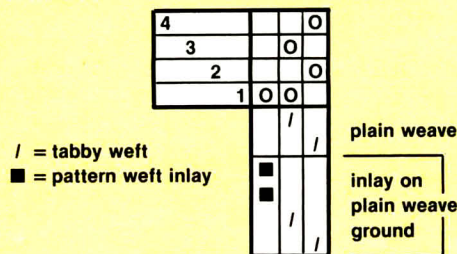

P.P.I.: 14 ground (2-ply or doubled singles).

TAKE-UP & SHRINKAGE: 9% in width and 2% in length.

WEAVING: This fabric resembles window screening on the loom but will bloom beautifully when washed and brushed. Use a temple to minimize draw-in and selvedge breakage. The plain weave ground fabric is woven with 1-ply yarns doubled for the border bands and with a 2-ply yarn used singly for the body and sleeves. The pattern inlay is worked with quadrupled strands of singles wools, using 2 strands of bright green and 2 of olive green together for the leaves, and 4 strands each of yellow for the lower flowers, pink for the upper flowers, and magenta for the upper flower centers. The coat is woven from front hem to back hem, and a piece is woven for sleeves and collar.

The border is 9" of graduated bands of dark brown, dark gray, light brown, and light gray, separated by 2 picks of bright green at each color change. The center is 60" of pale gray, followed by 9" of border in reversed order. The glit inlay is begun 2" into the first (dark brown) background band and is placed according to a graphed diagram. To ensure pattern matching at the side seams later, background band heights and relative inlay placements at the selvages are noted as woven on the front so that they can be duplicated in reverse order when the back is woven.

Pale gray 2-ply is woven 25" for the sleeves and collar, which have no banding or inlay.

FINISHING: All cut ends of the fabric are machine stitched and zigzagged very securely, as this is a rather loose weave. Weft tails are worked into the back of the

fabric and clipped close. The fabric is washed in mild detergent and warm water on a very gentle machine cycle, rinsed, and carefully spun until rid of excess water. While still damp it is blocked on stretchers and brushed (in background areas only) to raise the nap. It is allowed to dry as stretched and then lightly pressed.

ASSEMBLY: The coat is composed entirely of rectangles (the body, two sleeves, and the collar).

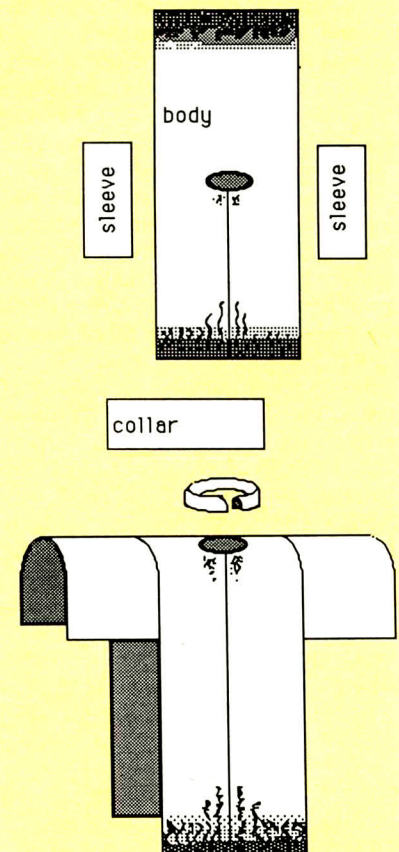

The 25" pale gray piece is stitched and cut apart from the body. It is folded in thirds warpwise to mark, flattened and stitched along these marks, and cut. (The selvedge pieces will be the sleeves and the middle will be the collar.)

The center of the coat body is marked. For the neckline, a smooth curve is marked connecting points from this center 1½" toward the back, 3" toward each side, and 2" to the front. This neckline oval and the remainder of the center front line are stay stitched and cut. Hems are trimmed, outside corners rounded; all cut edges are stay stitched to form a foundation for crocheted edging.

With stripes matched, each sleeve is sewn to the coat with the inner cut edge toward the body and the selvedge toward the wrist. The body/sleeve assembly is folded in half weftwise at the shoulder line, right sides together. The underarm and side seam on each side is sewn, ending 10" from the bottom of the coat body; underarm corners are clipped.

The collar piece is trimmed to fit the neckline and sewn to the coat right sides together, folded in half to the outside, and sewn at the front ends. Collar seams are trimmed; the collar is turned right side out and pressed. A narrow inner collar edge is turned under and hand stitched to the neckline.

The singles yarn is used double to crochet around the entire coat edge from left collar seam to right collar seam. Ties are crocheted at each collar seam and trimmed with tassels. Buttonhole loops are crocheted with the same doubled yarn, and buttons attached opposite them. Each cuff is knit onto a crocheted edge around the sleeve end. □

Cross-weave Tapestry

designed by Áslaug Sverrisdóttir
page 67

4 2

PROJECT NOTES: In Icelandic this technique is called "krossvefnadur", or cross-weave. It is a traditional weave in the Nordic countries, a weft-faced plain weave with discontinuous wefts making the changes in color. There are several variations of the technique, each named according to the method of joining adjacent weft colors. This variation's Icelandic name means "cross-weave, both sides alike". Because this weave has no right or wrong side of the fabric, it is useful when weaving chair or floor coverings. In these yarns it makes a firm, yet soft, table decoration.

FABRIC DESCRIPTION: Weft-faced plain weave tapestry.

FINISHED DIMENSIONS: 11½" wide by 59" long, plus a 4" fringe on each end.

WARP: Cotton 12/6 rug warp at 1400 yd/lb: 320 yd unbleached. (This is Borgs Mattvarp 12/6 DT, from Glimakra Looms 'n Yarns: #1260 unbleached.)

WEFT: Nm 10/3 tapestry wool at 1640 yd/lb: 1300 yd total of several colors such as gold, orange, amber, brown, dark red, burgundy, red-brown, navy, and sea-blue. (Comparable-weight 2-ply tapestry wools are available from such suppliers as Jagger-Spun, Novitex, Borgs, and Halcyon Yarn.)
E.P.I.: 8.

WIDTH IN REED: 12".

TOTAL WARP ENDS: 96.

WARP LENGTH: 3 yd, which includes take-up, shrinkage, and 27" loom waste.

DRAFT:

P.P.I.: ca 48-55.

TAKE-UP & SHRINKAGE:

Estimated ca 5% in width and length.

WEAVING: Leave at least 5" of warp unweaved for fringe at the beginning and end. Using the tapestry wool wefts, weave

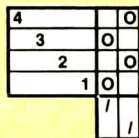

solid bands ad lib, and at intervals weave a band in tapestry motif. (See *Manual of Swedish Handweaving*, by Ulla Cyrus-Zetterström, for detailed instructions on tapestry weaving.)

FINISHING: At each end, knot the fringe

Pile Vest

designed by Merja Winquist
page 73

4 2

PROJECT NOTES: Originally, the pile weaves were a way of creating a woven substitute for fur bed coverings. The tufts of wool trap air and form excellent insulation in cold weather. This pile vest is a wonderfully warm, furry, heavy (over 3 lb) garment to wear with jeans and a turtle-neck sweater in casual style.

FABRIC DESCRIPTION: Pile on plain weave ground.

SIZE: Women's large. Circumference at hem 48". Length from highest point of shoulder 33". Back length from neck 31".

WARP & GROUND WEFT: Soft plied cotton at 1800 yd/lb: beige and tan. (These are similar to Helmi Vuorelma's Pilvi Nm 8/3 cotton, from Schoolhouse Yarns and Eaton Yarns: #506 beige and #410 tan.)

PILE WEFT: Assorted soft medium-weight wools: 3 to 3½ lb.

E.P.I.: 12 to 15.

DRAFT:

TAKE-UP & SHRINKAGE:

10% in width and length.

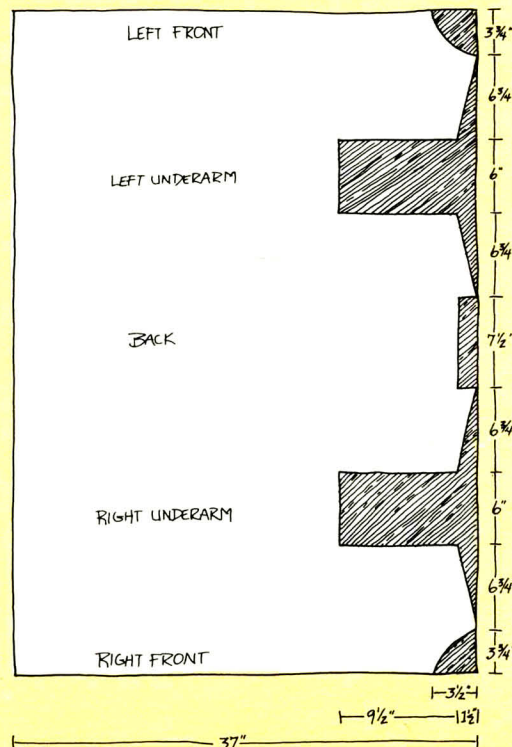
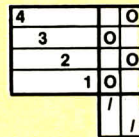

Woven sideways in non-directional pile

in groups of four warp threads, using an overhand knot tightened against the fell (woven end) of the runner. If desired, embellish the fringe by tying an additional knot 1" from the base knot in some of the groups. Trim both fringes to 4". □

WEAVING NOTES: Any of the pile techniques (such as weft loops, knotting, or double corduroy) could be used to weave this vest. The pile is ¾" long in rows ½" apart. If a directional or "napped" weave is used, the vest should be woven in three pieces on a 27" wide warp. (The back is one piece and the two fronts are side-by-side—all are woven with the pile pointing downward.) If the weave that is used makes a non-directional pile, the vest can be woven sideways on a 37" wide warp. Either way, the pieces can be shaped on the loom and the ends of unweaved warps turned back and woven into the fabric later with a needle. (A hint: occasionally insert rag strips, thrums, or other bulky wefts into the areas of unweaved warp in neckhole and armseye to maintain equal tension.)

This vest has pockets formed by weaving slits into the two front panels and then sewing rectangular fabric linings over the slit areas on the inside. The vest edges are all finished by overcast stitching by hand using three strands of matching pile yarns. Alternative edge finishes include fabric or leather binding, hand-knitted binding, and crochet. □

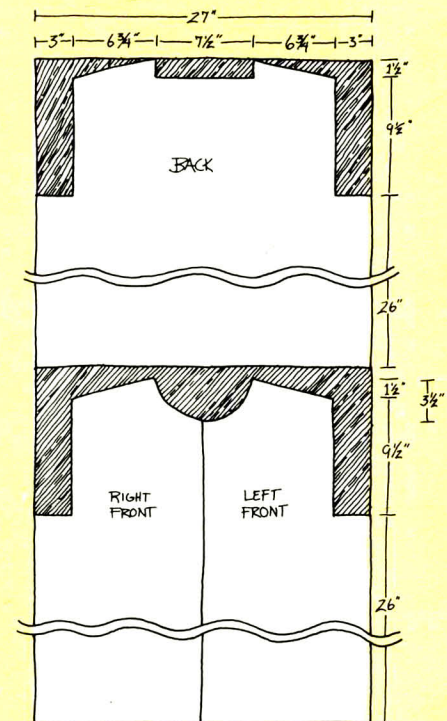

Woven lengthwise for directional pile

"Poppana" Shopping Bag

designed by Riitta Mäkinen
page 74

4 2

PROJECT NOTES: Bias-cut "poppana" cotton fabric strips are used to weave this sturdy, colorful shopping bag from Finland. Brushing the fabric raises the strip edges and gives the bag a surface textured like that of a dense chenille.

FABRIC DESCRIPTION: Plain weave.

FINISHED DIMENSIONS: 19½" wide (40" circumference at top) by 5½" deep at base by 14½" high, plus handles.

WARP: 6-ply cotton seine cord at 2740 yd/lb: 720 yd black (or 580 yd if handles are woven on a separate narrow warp). (This is Helmi Vuorelma's 30 Tex 6 Kalalanka from Schoolhouse Yarns and Eaton Yarns: #948 black.)

WEFT: "Poppana" ⅜" bias-cut fabric strips at 320 yd/lb: 450 yd wine, and 50 yd each purple and dark green. (These are Pirkanmaan Kotityö's poppana from Schoolhouse Yarns: #80 wine, #73 purple, and #50 dark green.)

NOTIONS: Heavy-duty sewing thread in matching wine, purple, and green; ¼"-wide single-fold bias binding in the same three colors.

E.P.I.: 10.

WIDTH IN REED: 24".

TOTAL WARP ENDS: 244 (240 plus doubled selvage at each side).

WARP LENGTH: 2¾ yd, which includes take-up, shrinkage, and 27" loom waste (or alternative: 2 yd full width, and a separate 2-yd narrow warp 24 threads wide for handles).

DRAFT:

P.P.I.: 15.

TAKE-UP & SHRINKAGE:

10% in width and
5% in length.

WEAVING: Weave with wine poppana weft for 7½", green for 1¼", wine for 25", purple for 1¼", and wine for a final 7½". For the handles, weave two side-by-side strips 24 threads wide and 22" long, using purple weft for one and green weft for the other. (If you have chosen instead to make two warps per the alternative given above, weave the bag as instructed on the wide warp and weave the handles end-to-end on the narrow warp.)

FINISHING: Securely machine stay stitch all cut ends of both handles and the bag. Cut the pieces apart between rows of stay stitching. Wash carefully in warm water—do not soak. (The poppana instructions warn that some dye may come out in the first wash, so wash colors separately from each other and from anything else.) Spin gently. Straighten the pieces and allow to air dry with the stripes vertical. Iron while slightly damp, and brush the outside face of the bag piece to raise a nap.

ASSEMBLY: (Note: this is a very firm, heavy fabric. Some of the seams are stitched through several layers and may require a heavy-duty sewing machine.)

To make each handle, place the woven strip face down and fold lengthwise, right side out, bringing the selvages to the center. Cover the join with matching-color bias binding and machine stitch along the edges of the binding through all layers of binding and handle with matching color thread.

Use wine sewing thread for the remaining assembly. At each end of the bag piece, turn under a 2" hem, making sure that the fold is the same distance from the colored band at each end. On each hem, center a handle face-out on the inside of the bag (green handle on the purple-banded end and vice versa). The handle ends should be about 6½" apart, and overlap the bag top by about 2". Machine stitch each handle to the large piece in a rectangular pattern through all layers of handle, hem and bag. Edge stitch the wine bias binding over the hem edges and handle ends on the inside at each end of the bag piece.

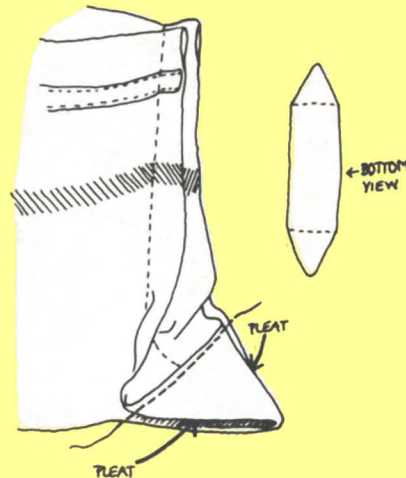

Fold the bag in half crosswise, right sides together, matching hems at the top and colored bands at the selvages. Seam the sides, tapering the seam allowances from ¾" at the top to 2" at the base (do not trim the seam allowances). Box the base by bringing the side seam to the fold at the bottom of the bag. Stitch across the triangular corner as shown. Turn the bag right side out. (By this assembly method, all cut edges are covered with binding, and all exposed edges are woven selvages.) □

Tussah Silk Top

designed by Debbie Buchele
page 91

4 2

FABRIC DESCRIPTION: Plain weave.

SIZE: Women's medium. Circumference at bust, 37". Length from shoulder, 22".

WARP & WEFT: Bleached tussah silk singles at 10,000 yd/lb: 2420 yd.

NOTIONS: Sewing thread, wooden button.

E.P.I.: 18.

WIDTH IN REED: 26".

TOTAL WARP ENDS: 468.

WARP LENGTH: 2¾ yd which includes take-up, shrinkage and 27" loom waste.

DRAFT:

P.P.I.: 18.

TAKE-UP & SHRINKAGE:

25% in width
and length.

WEAVING: Starting at the lower edge of the front, weave 25". With two shuttles, weave an 8½" long slit for the center front opening.

Adding two shuttles to weave the front neck facings, make two more slits 4" from the center front slit. Weave ½" with all four shuttles. Drop the shuttles that are weaving the front facings and continue to weave the shoulders for another 3".

Add a shuttle to weave the back facing for ½". The slits at each side of the neck should now measure 4". Finally, with one shuttle, weave 30" for the back.

FINISHING: Machine stitch all raw edges. Handwash in cool water with mild detergent and air dry. Press with a damp cloth to prevent shine.

ASSEMBLY: To form the tucks, press a horizontal fold 1" below the front slit and stitch ⅝" from the fold. Measure downward 1½" from the stitching line, press another fold and stitch as before. Measure and stitch once more for the third tuck.

When the top is folded in half along the shoulderline, 2" of the neck opening will be in front and 1" should be in back. Adjust length at the lower edge, if necessary, and sew sideseams leaving 8½" armhole openings.

At back neck opening, make a narrow hem turning under the raw edge twice and handstitching in place. At the front neck openings, turn under the raw edge, then fold again diagonally so that the opening at the center front is 1" lower than the corners. Handstitch in place.

Sew a wooden button on the left corner of the opening, and sew a loop inside the right corner. Finish the lower edge with a narrow hem. □

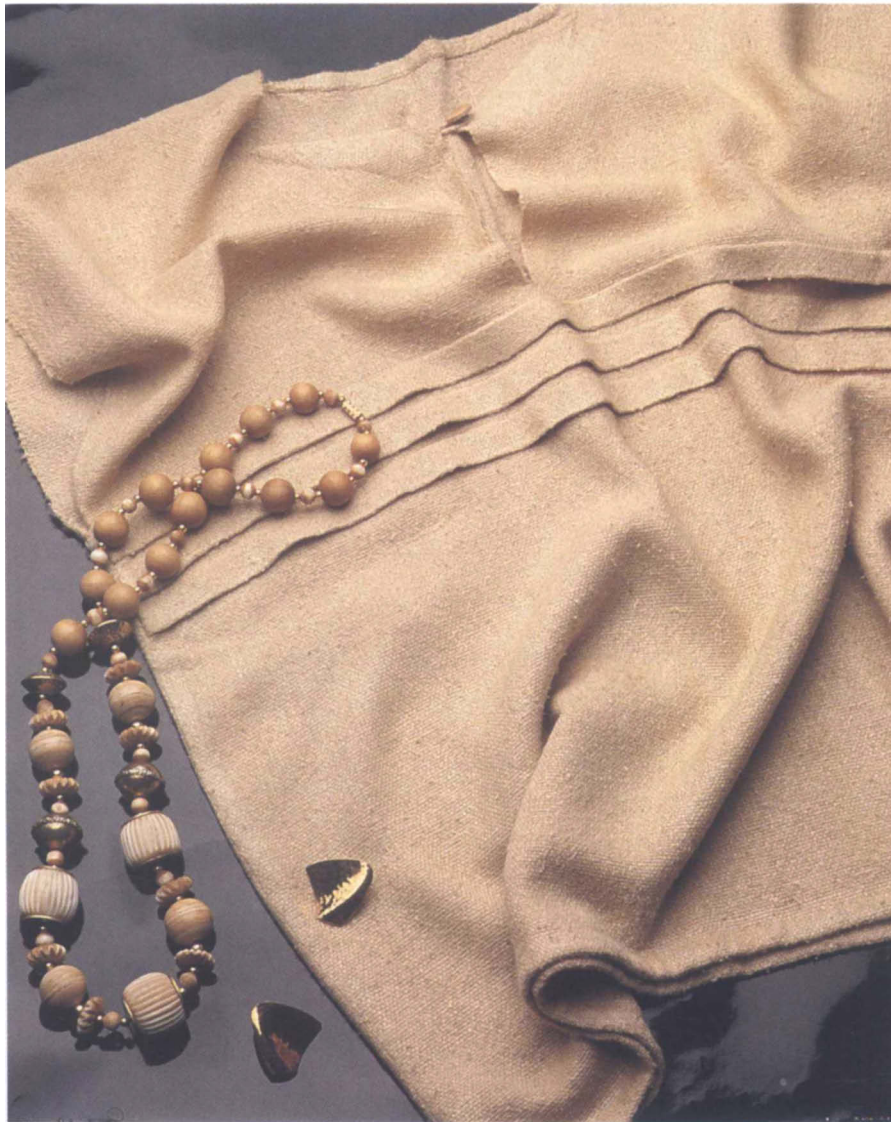

KEEP IT SIMPLE

Inspiration for this Tussah Silk Top came from a top that Debbie Buchele saw in *HANDWOVEN's Design Collection #1*, woven by Diane Terry. Debbie wanted to weave a silk top with the same soft look and feel as the top with vertical pleats that Terry had woven for the *Design Collection*. Debbie's variation features horizontal tucking which she designed by playing around with a remnant of gauze fabric. "I am very pleased with the versatility of the design and find myself wearing it constantly," write Debbie. The simple elegance of this project, as well as the ease with which it can be woven and constructed, made it a winner with our Keep It Simple judges. For complete instructions for our Tussah Silk Top, please see the Instruction Supplement.



YARNBARN



MILL END SAMPLE CLUB

\$3.00/6 mailings a year

wools, cottons, acrylics, silks, linens



918 Massachusetts
Lawrence, Kansas 66044



Classifieds

NOTICES

TO PLACE A CLASSIFIED AD

For the next issue, send your ad along with payment eight weeks prior to the month of publication. Only **\$1.00 per word (\$20 minimum) or \$45/col. inch (camera-ready)**. Payment must accompany ad. Send to **Interweave Press, Handwoven Classified Ads**, 306 N. Washington, Loveland, CO 80537.

CARDWOVEN EARRINGS 2" long, sewing thread. Really cute. \$7/pair. State color, alternate; pierced or clip. Send SASE for free price list, pictures. **Herbi Gray**, P.O. Box 2343, Olympia, WA 98507.

CRAFT/FOLK ART TOURS 1987. Poland/Czechoslovakia; Romania/Hungary; Yugoslavia; USSR; Himalayan Weaving Workshop; Spain/Morocco; Kashmir/Ladakh; Thailand/Burma. **Craft World Tours**, HW-7, 6776 Warboys Rd., Byron, NY 14422. (716) 548-2667.

LLAMAS!! Own your own gentle companion and colorful, luxury fiber producer. Breeding stock, trained packers. Large SASE to **Dale Pettigrew**, Overland Trail Llamas, Rt. 1, Livermore, CO 80536. (303) 493-2335.

PRODUCTION WEAVERS: Interested in selling your product? Jobber now seeking dependable sources of unique, high-quality, handwoven fabrics to represent to stores nationwide. Respond immediately: **Fourth Dimension Fabrics**, 4560 Alice, San Diego, CA 92115.

SCOTLAND—June 13-28. Weavers/spinners. Seminar: Isle of Arran with Lynn Ross, plus tour of Outer Hebrides. Contact **Barbara Moore**, 810 S. Renaud, Grosse Point, MI 48236.

WANTED: OFFICE MANAGER/SECRETARY. Mail-order yarn business. ¾+ time. Good communication skills. Benefits: yarn discounts, profit-sharing. Remote rural town; subtropical desert. Mountain, lakes nearby. Send resume & imaginary customer complains & response (in longhand) before August 1. **Cotton Clouds Job**, Rt. 2, DH #16-HW, Safford, AZ 85546.

WEAVERS SHOW-SALE-AUCTION, October 3, 4. Open to all woven media. Booth space \$40. Held at the American Victorian Museum, 325 Spring St., Nevada City, CA 95959. Contact Michele at (916) 265-2644 or (916) 265-5804.



Discount Yarns
Tools and Accessories
Write for Samples

CRANBROOK • NORWOOD • SCHACHT • LOUET
WEAVERS' WAREHOUSE

1780 Menaul NE Albuquerque, NM 87107 • 505-884-6044

FIBER FORUM

September 18-20, 1987

- 13 workshops •
- Top instructors in weaving & spinning •
- Whidbey Island (near Seattle) •

For information, send SASE to
FIBER FORUM, P.O. Box 611-H,
Coupeville, WA 98239.

Sponsored by Coupeville Arts Center
(a non-profit organization)



MILL ENDS BY MAIL ORDER? We sure do. **FREE SAMPLES?** Just ask. **GOOD PRICES?** Terrific. **AND DISCOUNTS?** Nobody does it better!

For current samples, write to **WEBS**, P.O. Box 349, 18 Kellogg Ave., Amherst, MA 01004. Or call (413) 253-2580.

*Heirloom Linens...
and other strands*

presents

High Quality Wet-Spun Line Linen
from Northern Ireland

**Create tomorrow's
heirlooms**

Wholesale & Retail Samples \$3.00
Kirkfield, Ont., Canada K0M 2B0



*Great Northern
Rug Weaving Supplies*

Large volume means lower prices on 8/4 cotton warp, beautiful cotton & wool rags, rug filler, loopers, braiding equipment and more. For samples and price list send \$1.00 handling to: **Great Northern Weaving**, P.O. Box 361B, Augusta, MI 49012

MANUFACTURED and SOLD by SPECIAL PRODUCTS COMPANY
P.O. Box 24 Afton, Wyo. 83110



Precision machined steel
Long tapered shaft, fits
both paper quills and
bobbins. High speed ratio.
Fits most spinning wheels,
replaces flyer. Please
include brand and
model info.

307-886-3486
Dealer Inquiries
Invited

Darlene's 26⁵⁰ PPW

Bobbin
winder

MADE In U.S.A.

DYEING

ACID WOOL DYES, Procion MX, Deka, natural dyes, mordants all packed in opaque, rigid, resealable plastic containers. Uncut, un-mixed—straight pigments and accessories—top quality at bargain prices, since 1970. Catalog \$2 (credited to first order). **Earth Guild**, Dept. HW, One Tingle Alley, Asheville, NC 28801.

CLOSE-OUT ON KITON ACID DYE Samplebook for wool. Over 600 samples for 6 basic colors. Was \$67.50—now only \$47.50 ppd. Inquiry or check: **Jean Scorgie**, 1050 Fillmore, Denver, CO 80206.

FULL STRENGTH, commercial-quality dyes for wool, silk and all fibers. Lanaset dyes, Cibacron F and PROcion MX fiber reactive dyes; PROcion H, liquid & powder. Reactive dyes as well as liquid Reactive dyes. Electric & manual tjangtings; plus auxiliaries required for the surface coloration of fiber. Write for free information and catalogue. **PRO Chemical & Dye, Inc.**, P.O. Box 14, Somerset, MA 02726. (617) 676-3838.

MICROWAVE DYE KITS

\$20.00

Plus \$2.00 handling and shipping.
California residents add 6% sales tax.

- Space dyed wool yarns • Heather yarns
- Variegated rovings • Rainbow fleece

This complete kit includes easy-to-follow instructions
and dye for 10 to 60 pounds of wool.

California Colors 1075 W. Twentieth St.
Upland, CA 91786
714/982-9600

A SYSTEM FOR THE CONTROLLED USE
OF REACTIVE DYES ON NATURAL FIBERS

DYEKIT

- The Home-Dyer's Helper
- All the Necessary Instructions, Dyes, and Measuring Equipment
- Dye Hundred's of Colors on All Natural Fibers
- Look for DYEKIT in your local fiber supply shop or send \$27.50 + \$2.00 postage to: DYEKIT, 7797 Quivira Rd., Lenexa, KS 66216



SPINNING WHEELS & LOOMS



SPRING CREEK FARM

Looms, wheels, carders, fleece and sheep. Quality products and prompt service. Write for brochure.

Spring Creek Farm
Box 466-H, Mound, Minnesota 55364

EQUIPMENT

BOND KNITTING FRAME (\$190+ shipping). Schacht and Louet looms and wheels. Manos and Nature Spun yarns. Check our prices. SASE for catalog. **The Wool Room** (H), Laurelton Rd., Mt. Kisco, NY 10549.

CARD AND BLEND exotic fibers. Exciting new table-top carder designed to process all fibers including silk, angora bunny, mohair, alpaca, llama, cashmere, Merino and dog hair. **New Motorizing Unit** available for all Patrick Green carders. Write or phone for details. **Paula Simmons**, 48793 Chilliwack Lake Rd., Sardis, B.C., Canada V2R 2P1. (604) 858-6020.

FOR SALE: Large collection of textile antiques; looms, wheels, winders, etc. Send for inventory/prices. P.O. 241, Montchanin, DE 19710. (302) 571-8686.

45" LECLERC counterbalance loom. Four-harness, six treadles, bench and five reeds. \$450 plus shipping. **D. Schlie**, (219) 627-3423.

HUMDRUMMER electric drum carder for spinners, felters, and crafters. An electric drum carder to speed your wool carding and batt making. A Louet drum-carder with the Markmotor added. Free brochure from **River Farm**, Rt. 1, Box 401, Timberville, VA 22853, or call 1-800-USA-WOOL or (703) 896-9931.

LOOMS—22" & 36", 4-6 harnesses, 6 treadles. Individually handcrafted from Appalachian maple. New: 22" hand-operated floor loom for the "physically challenged". **Old South Looms**, P.O. Box 867, Cowpens, SC 29330. (803) 463-4941.

REEDS—Over 100 years experience. Handloom reeds with carbon or stainless steel dents. Metric dentages available. **Whitaker Reed Co.**, 90 May St., Worcester, MA 01602.

THOUGHT PRODUCTS "BARBARA 5" LOOM, #72, made in 1978. Jack, counterbalance and/or counter-marche. 12-harness, 52" weaving width. Two-harness tapestry vertical from top of loom. Sectional or plain back beam. 700 lbs. Solid cherry. Approx. 7' tall, 6' wide, 6' deep. Comes with 4' cherry bench with sliding seat, 4' shelf and foot bar. Also 6' x 3' free-standing solid cherry warping board and two reeds. Mint condition. \$3000. Contact **David L. Daily**, 4319 Courville, Detroit, MI 48224. Daytime (313) 893-9745; night (313) 885-0023.

For select knitting tools and accessories,

inquire: **The Sweater Workshop**

Jacqueline Fee Box Five
Hingham, MA 02043

DAFT JAMES HANDCRAFTS

See our sample sets in your home. Select from a large variety that is certain to please you. Order those sets of specific interest, only \$5.50 each.

1. 5/2 PERLE COTTON
 2. 16/2 MERCERIZED COTTON
 3. COTTON FLAKE
 4. SILK
 5. SHETLAND WOOL/POLYESTER
 6. RAYON CHENILLE
 7. NATURAL COTTON WARPS
- Quantities large or small, we rapidly fill them all.
P. O. BOX 148A, AKRON, NY 14001

USED LOOMS, all sizes. Send \$1 and SASE for listings, in WA, ID and OR to **The Loom Exchange-LL**, Greenwood Station, P.O. Box 30089, Seattle, WA 98103.

WARP PACKING STICKS. Tired of tension problems? Try warp packing sticks for smoother warp beaming. For information send SASE to **Washington Wool Works**, 817 N. 150th St., Seattle, WA 98133.

WOOL PICKERS®, **WOOL COMBS**®, **BLOCKERS**®, **Skein Winders**®. Flax processing equipment, and accessories for each made from hardwood, finished with Danish oils and/or plasticized; each designed and crafted for handspinners by Meck. For more information send SASE **Meck's**, P.O. Box 756, Cornelius, OR 97113. Phone (503) 628-2696.

Louet, Leclerc, Ashford, Lendrum
Weaving and Spinning Equipment.

Yarns, Books, Dyes, Bond Knitting Machine.
Fibers, Lessons. Catalogue \$2.00

Smith & Ewe

MARY ANNE SMITH, 2009 Tranquille Road
Kamloops, B.C. V2B 3M4 Phone (604) 376-3139

WEAVERS' RAG CUTTER—RIGBY

The original cloth stripping machine, Model B, for cutting strips of cloth from 1/2" to 2" wide suitable for weaving and braiding. Price \$63 plus \$4 shipping. Other models available for hooking and cutting strips 1/8" to 3/4". **Rigby**, P.O. Box 158, Dept. HW, Bridgton, Maine 04009.

kessenich looms

HAND CRAFTED
CUSTOM BUILT

CHOICE RED OAK

Foot & hand operated

Floor & table looms

All Collapsible

Retail Only

7463 Harwood Ave.
Wauwatosa, WI 53213

SPECIAL PRICE

the only authentic
PAULA'S PICKER

FULL SIZE ECONOMY MODEL
PROFESSIONAL QUALITY
PRESANDED MAHOGANY
YOU APPLY THE WOOD FINISH
\$225 US

(includes postage & duty)

Order now from
PATRICK GREEN CARDERS LTD.
48793 Chilliwack Lake Road
Sardis, B.C. V2R 2P1 Canada

FIBERS

BASKET REED: round, flat, flat-oval, cane, spline—34 sizes. Round wooden hoops, 3" to 23", oak and poplar, 23 sizes. Rectangles, D's, ovals, U's—26 sizes. Dyes, tools, books. Catalog \$2 (credited to first order). High quality, low prices, fast service. **Earth Guild**, Dept. HW, One Tingle Alley, Asheville, NC 28801.

BASKETRY MATERIALS. Complete line of basketry reed—ash, poplar & oak splints; handles, bands, hoops, rattan rings, cane and caning supplies. To add texture and interest to your baskets—seagrass, grass or palm rope, palm coir, and a variety of bulky yarns including handspun. SASE for brochure/price list. Samples: basketry \$1.50; bulky yarns \$1.50. **Linda Snow—Fibers**, Fiber Headquarters of the Southeast, 3209 Doctors Lake Dr., Orange Park, FL 32073.

BEAUTIFUL PRICES FOR BEAUTIFUL YARNS! Mill-ends and discontinued yarns. Special sales of first-run yarns. \$1 + SASE for sample mailing and information. **The Weaving Wagon**, 8505 Brickyard Rd., Potomac, MD 20854.

CANADIAN YARNS RETAIL. Fine wools, tweeds, mohair, cottons, fancies, linen 35/2 to 10/6. Price & sample lists. Mailing to U.S. \$1. **Talisman Clay & Fibre**, 1370 7th Ave., Prince George, B.C., Canada V2L 3P1.

DESIGNER RIBBON in 65 colors to weave, knit. \$2.75 for samples, patterns, catalog, shuttle pins, "sheep" gifts. Also "MAGIC"—beautiful, textured yarn, great price! 75% rayon/25% cotton. Cones, 650 yards/lb. 35 inspirational colors. Samples, \$2.65. **Creative Designs**, 916 Morning Sun, Olivenhain, CA 92024.

DISCOUNT FIBRES. Weavers, spinners, knitters. Wool, silk, cotton, linen, rayon, synthetics. Samples \$3.75; foreign \$5 (US funds). **North Shore Fibre Arts**, Box 17168, Dept. HW, Milwaukee, WI 53217.

EXOTIC FIBERS. Cashmere, camel, mohair & alpaca yarns. Now in spinning fibers too! Yarn samples \$1 plus #10 (large) SASE (\$.56). **Custom Handweaving**, Box 477, Dept. H, Redondo Beach, CA 90277-0477.

FLEECE: Black, brown, greys, whites. Lovely for spinning, weaving. \$3/lb by the fleece. Send SASE for samples, information. **Georgia Wolterbeek**, Fairmount Farm, Rindge, NH 03461.

FREE CATALOG WAITING for you! Exciting selection of hard-to-find spinning fibers. Popular domestic and imported yarns. Mail order samples: Fiber \$3, yarn \$3. **Curtis Fibers**, Rt. 1, Box 15H, Ritzville, WA 99169.

HISTORICAL VEGETABLE-DYED wool yarns for coverlets, blankets, clothing and home furnishings. Quality yarns, gorgeous colors. Brochure, samples \$1. **Indigo Unlimited**, 26 Bouker St., Greenfield, MA 01301.

JUST WHEN YOU THINK you have seen all the silk yarns and silk fibres possible . . . here come 12 more from **The Silk Tree**, Select Silks, Inc., Dept. H2, Box 78, Whonnock, BC, Canada V0M 1S0. Please send \$4 for samples.

LINEN RUG WARP 8/5. Highest quality from Ireland. Professional weaver's put-up on 2-lb tubes. Please send SASE for quantity prices & samples. **Glimakra Looms 'n Yarns**, 1304-A Scott St., Petaluma, CA 94952. Call (800) 843-9276 or (707) 762-3362. M/C & VISA welcome.

FIBERS (cont.)

LINEN TOW YARNS. \$3-\$4.75/lb (natural & bleached 7/1, 10/1, 13/1 & 14/1) and \$6/lb (for 10/2 & 10/3). Please send SASE for order info & samples. **Frederick J. Fawcett, Inc.**, 1304 Scott St., Petaluma, CA 94952. (800) 432-9238. CA (800) 232-9238. M/C & VISA welcome.

LUXURY FIBERS: alpaca, silk and blends. Treat yourself to the very best! Free samples with SASE. **The Fiber Connection**, P.O. Box 81123, Las Vegas, NV 89180. (702) 362-1405.

MILL END AND first run yarns. Cottons, wools, linens, synthetics and blends. Naturals, colors, novelties. Complete yarn samples \$6. **Earth Guild**, Dept. HW, One Tingle Alley, Asheville, NC 28801.

MILL END YARNS, threads, etc. Natural, synthetic and blends, varied sizes and types. New items added constantly. Low mill end prices on yarns. Sample catalog and mailing list for 1 year \$2. **The Gleaners Yarn Barn**, P.O. Box 1191, Canton, GA 30114.

MILL ENDS—Naturals, whites, colors. Wool, wool blends, cotton. Quantity discounts. \$1 to \$6/lb. Send \$1 for samples. **Contemporary Fibers Studio**, Dept. H, 623 High St., Worthington, OH 43085.

!! COVERLET WEAVERS !!
UNMERCERIZED COTTON

10/2	4 lb. cone	16,800 yds.	20.00
20/2	4 lb. cone	33,600 yds.	20.00
20/3	4 lb. cone	22,400 yds.	20.00

Plus Shipping
THE MANNINGS
 P. O. Box 687, East Berlin, PA 17316
Orders: 1-800-233-7166

Texas Fibers
 brother
 KNITTING MACHINES
 spinning wheels
Cranbrook
 Counter March Looms

KID MOHAIR
 FINE WOOL
 SILK • ALPACA
 CAMEL DOWN

Fiber Samples 2¢
 1400 WILLIAMS DRIVE
 GARLAND, TEXAS 75042

Natural Fibers Only
Gorgeous Yarns - Reasonable Prices

- Stock Samples - Cottons, Wools, Rayons - \$3.00
- BOND Knitting Frame & Accessories

NEW Designer Knitwear Kits
 SASE FOR DETAILS
 PO Box 1602H, Bloomington, IN 47402

SAMPLES
KNITTERS & WEAVERS

- COMPLETE SAMPLE SET \$2.00
- FEATURING MONTHLY SPECIALS

COTTON: 3/2's • 5/2's • Warp Poppina (Cloth Strips)
 WOOL: 2 Ply • Bulky Warp Tweeds • Solids

LOCC'S YARN CO.

Quality stock for knitting, hooking and weaving. LoCC's Yarn Co. is your source for fine cottons and wools - shipped promptly - your satisfaction guaranteed! Send today for a Sample Set (\$2.00) and we'll place you on our mailing list for exciting "Monthly Specials".

P.O. BOX 231 - DEPT. E. • DECATUR, GA. 30031-0231

MILL ENDS, wools, cottons, synthetics and blends, all sizes and textures, for weaving or knitting machines. Mill end mailings, at least four per year. \$3. **Linda Snow-Fibers**, Fiber Headquarters of the Southeast, 3209 Doctors Lake Dr., Orange Park, FL 32073.

NATURE'S PALETTE hand-dyed Romney cross-bred fleeces. Long, lustrous, beautifully multi-colored handspinning delight. Become a true fiber artist! Samples \$1. **Otter Lodge**, 242 N. Sherwood, Ft. Collins, CO 80521.

POPPANA BIAS CUT cotton strips from Finland. Excellent for weaving table cloths, clothing, covers. \$1.65 per roll. 33 colors, samples \$1. **Miranda Imports**, 2S977 Shagbark, Batavia, IL 60510. (312) 879-3335.

PREMIUM OREGON FLEECE grown, selected and skirted by a professional spinner. White and colored fleeces \$2.50/lb plus postage. Send SASE for samples. **Hungry Hill Homespun**, 39918 N. Ruby Rd., Scio, OR 97374.

RAYON CHENILLE. Odd lots, assorted colors, approx. 1000 yds/lb. Send SASE for samples. **The Fiber Studio**, P.O. Box 637, Henniker, NH 03242. (603) 428-7830.

SHEEPSKIN PIECES. Cleaned random sizes suitable for cutstrip weaving. Makes wonderful rugs, vests, seatcovers. Instructions with order. 1 lb \$4; 5 lbs \$16; 10 lbs \$28; plus shipping. **Custom Handweaving**, Box 477, Dept. H, Redondo Beach, CA 90277-0477.

SILK; BLACK; RED. \$85/lb special thru August. All styles yarn. Natural and dyed silks, samples \$10. **Cheryl Kolander/Aurora Silk**, 5806 N. Vancouver, Portland, OR 97217. (503) 286-4149. VISA.

SILK, SILK, SILK. 60 exciting colors—Douppioni; 2/14 spun; cultivated & tussah plied; silk & camel; tussah & acrylic. Quantities limited. Samples \$5. **Custom Handweaving**, Box 477, Dept. H, Redondo Beach, CA 90277-0477.

SUPREME CHAMPION FLEECE at 1986 National Wool Show bred from our Romney bloodlines. Beautiful fleece, carded fibers and handspun yarns. Angora/mohair/lambswool blends in 16 colors. Custom work. Discounts. Catalog, samples \$3. **Oregon Romney Wools**, 1780 Cleveland Hill Rd., Roseburg, OR 97470. (503) 673-7913.

"WONDERFUL YARN", Wholesale, bulk, cottons, rayons, novelties. Send \$2 for samples and prices. **Dariff Design Associates**, Dept. HW, P.O. Box 361, Cedarhurst, NY 11516.

WOOL MILL ENDS, 2 & 3 ply. Send SASE for current samples. \$4/lb + shipping. Louet products also available. **Eileen Bordelon**, 12918 Wolf Rd., Grass Valley, CA 95949. (916) 268-1271.

QUALITY NEW ZEALAND HANDCRAFT FLEECES

Beautiful fleece wool, specially bred for handcraft people. Clean fleeces, long staples (5" plus) weighing 6 lbs. Different breeds and colors available.

Prices per LB, white and colored US \$2.95, p&p extra. Carded wool available. Brochures and samples, no charge.

Orders sent promptly in a very personal manner.
JANETTE MCKENZIE
 Gorrie Downs, Greta Valley, R.D.
 North Canterbury, New Zealand

INSTRUCTION

COMING TO ENGLAND? Residential spinning and weaving tuition offered in well-equipped country studio. For brochure write **Malcolm and Elizabeth Palmer**, Crown Cottage, Gretton, Northamptonshire, NN17 3DE, England.

FELTMAKING. "I offer personal tuition to overseas visitors in my garden studio for either a one-day Introductory course or a two-day Beginner course." Contact **Freda Walker, Feltmaker**, 2 Helsington Rd., Kendal, Cumbria, LA9 5JR England UK. (0539) 22107.

HEART'S DESIRE RETREATS will find Sharon Alderman, Karen Selk, Michele Wipplinger, and Celia Quinn teaching this fall in Western Washington and California. Contact for details **Jinny Hopp**, 31510 44th Avenue East, Eatonville, WA 98328. (206) 847-5422.

LILLY BOHLIN WEAVING WORKSHOPS. Instruction on Swedish looms by internationally known Swedish weaver. **Lilly Bohlin's Studio**, 1507 Fell St., Victoria, B.C., Canada V8R 4V9. Tel: (604) 592-1262.

LOOKING FOR MORE INTERESTING WORK? Become a professional weaver or weave for fun. One-week, intensive 2-harness weaving retreat in Colorado mountains. \$375 covers tuition, room and wool. Individualized instruction. April-October. Send for brochure to **Robert Loewe Weaving School**, Box W, Divide, CO 80814. (303) 687-3249.

PRODUCTION WEAVING. Seven quarter comprehensive weaving program includes technique, design, business, marketing, studio planning and dyeing. Well-equipped studios. Low tuition. Located in Smokey Mountains. Contact **Production Crafts**, Dept. H, Haywood Technical College, Clyde, NC 28721. (704) 627-2821.

RIVER FARM WEEKENDS & FIBER SATURDAYS. March-August, 1987. Beginner, Intermediate, and Advanced Spinning, Priscilla Blosser-Rainey, Sheep Management, Jerry Rainey, A Weaver's Garden, Rita Buchanan, Indigo Dyeing, Maretta Crider, Basketry, Vikki Katon. Weaving, Maretta Crider/Jeff Lefkowitz. Bed and breakfast is available at River Farm House for all weekend workshops and Fiber Saturdays. Write or phone for details. **River Farm**, Rt. 1, Box 401, Timberville, VA 22853, toll free 1-800-USA-WOOL or (703) 896-9931.

SWEDEN THIS SUMMER. All ages. International group. Study language, Scandinavian democracy. \$900. Four weeks. Tuition, room, meals, trips. **William Hendriksen**, 33266 Roadem, Mancos, CO 81328.

RIVERWALK
 WOOLS COTTONS
 SILKS & BLENDS FOR
 WEAVERS & KNITTERS

YARNS

- 1st Quality Mill Ends & Leftovers •

2/16 & 2/8 Worsted Wool, 1/2-cross & ratinee boucles - TOP GRADE - Lots of colors **\$6.50/lb.**

Cotton Flake @ 3,000 yds/lb. appx. 35 colors **\$6.50/lb.**

Brushed Acrylic @ 2500 yds/lb appx. 40 colors **\$8.00/lb.**

Send \$2 with LSASE for samples:
 1912 River Road, Burlington, NJ 08016
New mailing every 2 months 609-386-9245

STORE OPEN TO THE PUBLIC 7 DAYS



The Northern Vermont School of Fiber Arts
PO Box 4115 • St. Johnsbury, Vermont 05819
Intensive Study Programs - January & June
Beginning & Advanced Studies in Fiber Arts
College Credits Available Send for Details

send SASE for ordering information



Lasana Wools
handspun • plant dyed yarns
of wool • silk • mohair / carded blends for spinners
p.o. box 2461 TAOS NM 87571 505/758-9631

Charlie's LONGHORN WEAVERS

- Discount yarns for knitting, weaving, and crocheting
- Fibers for spinning
- Looms, spinning wheels, carders, and accessories

1203 W. 11th • Coffeyville, Ks. 67337
316-251-8775

TWA WEAVERS SINCE 1938

- DISCOUNT YARNS
- HANDWOVEN FABRICS
- FREE SAMPLES

P.O. BOX 663 ALBUQUERQUE, N.M. 87103 • 505-242-4882

Egen Weaving Studio
The Glimakra® Weaving
School of Tucson

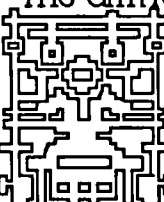

looms* yarns
spinning wheels
2233 E. Hawthorne
Tucson, Az. 85719
(602)325-0009

GREECE - MOREA Weaving Center
offers 2-week courses, June to
September, on the eastern coast of the
Peloponnese: Traditional Greek
Weaving Techniques, Folk Costume
Weaving, Natural Dyeing, Oriental
Knotted Pile Carpets. Visits to textile
collections. Details: Katerina Kalamitsi,
Box 27009, 11702 Athens, Greece.

Silk Fiber Portfolio

- An Exciting Study Adventure
- Descriptive Information • Directions
- Samples—\$15.00 plus \$2.00 shipping
US/Canada.

Send SASE for prices of Silk Fibers,
Caps, Cocoons. **Fallbrook House**, RD2,
Box 17, Troy, PA 16947. (717) 297-2498

LITERATURE

"AN ILLUSTRATED GUIDE to Making Oriental Rugs" by Gordon Scott. The first English-language how-to book on making your own loom and hand-knot rugs. Includes list of sources for supplies and nine authentic patterns. Send \$14.95 plus \$1.50 shipping. **Pacific Search Press**, Fiber Arts Dept., 222 Dexter Ave. North, Seattle, WA 98109, or call 1-800-858-0628.

"AUSTRALIAN LOCKER HOOKING: A New Approach to a Traditional Craft" by Joan Z. Rough. Turn unspun wool into beautiful, durable, machine washable rugs, clothing, and wall hangings. No experience or expensive equipment needed. 60 instructive pages include 21 photographs, 20 illustrations, and locker hook. \$6.95 plus \$1.35 shipping. **Fox Hollow Fibres**, 560 Milford Rd.-1, Earlsville, VA 22936.

"THE CHILKAT DANCING BLANKET" by Cheryl Samuel. A blend of history, legend, and how-to instruction on this rare Northwest Coast Indian art form. Send \$29.95 plus \$1.50 shipping. **Pacific Search Press**, Fiber Arts Dept., 222 Dexter Ave. North, Seattle, WA 98109, or call 1-800-858-0628.

"FIBRE FORUM" has a new look, and a new, low discounted price. Cost in 1987 is US \$12 for three issues. The new look includes a lot more colour. Subscribe in US dollars to **A.F.T.A.**, P.O. Box 77, University of Queensland, St. Lucia, Q4067, Australia. "Fibre Forum" covers all the textile arts in the Australian region, and is a high quality magazine. (For sample issue, send US \$4; or US \$6.50 for airmail. Make checks payable to "Fibre Forum".)

BESTSELLERS BY BETTE HOCHBERG BOOKS FOR SPINNERS WEAVERS & KNITTERS



HANDSPINNER'S HANDBOOK. Practical directions for spinning on the wheel. \$5.95

FIBRE FACTS. Guide to fibres & yarns. Choosing, using, finishing, care. \$5.95

SPIN SPAN SPUN. Lively collection of spinning & weaving myths, legends. \$5.95

HANDSPINDLES. Reviews history, use of spindles. Instructions for spinning with all ethnic styles. \$5.95

REPRINTS OF 16 TEXTILE ARTICLES from U.S., overseas magazines. \$4.95

At local stores, or mail order from: **STRAW INTO GOLD**, 3006 San Pablo, Berkeley, CA 94702

(Add \$1 shipping one book, \$1.50 for two)

WOODSEGE WOOLS

Luscious Spinning Fibers
Special Yarns

Learn To Spin Kit
\$12.45 ppd.

Visit our store or mail-order.
Newsletter subscription \$2.
Linda Berry Walker,
P.O. Box 275-HW,
Bowne Station Rd.,
Stockton, NJ 08559.
(609) 397-2212.

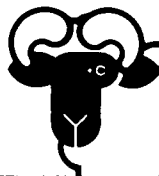

FIRE!! OUR OFFICES BURNED, but we're still here to sell! "Lacemaking Today", newsletter for lace-makers, is \$10 for a one-year subscription (6 issues). Books by Olive and Harry Linder: "Handspinning Cotton" (\$7.95+\$1 postage), "Techniques of Code Drafting" (\$16.50+\$1 postage), and "Handspinning Flax" (\$8.95+\$1 postage). **Bizarre Butterfly Publishing**, 1347 E. San Miguel, Phoenix, AZ 85014.

"THE GUIDE TO SUCCESSFUL TAPESTRY WEAVING" and "Patterns for Tapestry Weaving" by Nancy Harvey. This 2-volume self-study course gives step-by-step instruction for beginning to advanced weavers plus 21 patterns and advice on how to develop your own designs. Send \$25 for the set or \$12.95 for single title plus \$1.50 shipping. **Pacific Search Press**, Fiber Arts Dept., 222 Dexter Ave. North, Seattle, WA 98109, or call 1-800-858-0628.

"LANDSCAPE WEAVING BOOK". Complete instructions, photos, diagrams. \$5.95 plus \$1.20 postage. **Traicoff Books**, 640 E. Draper St., Mesa, AZ 85203.

"MEXICAN TAPESTRY WEAVING" by Joanne Hall. Weave beautiful Native American patterns as well as basic tapestry techniques. Many patterns are included P.O. Box 4022, Helena, MT 59601. \$12.95 plus \$1 postage.

"PATTERN DEVICES FOR HANDWEAVERS". Detailed instructions for Beiderwand, damask, double weave, twills, supplementary warp and weft using standard looms, pick-up methods or special devices: long-eyed heddles, drawlooms, etc. \$18 plus \$2 shipping. Dealer inquiries welcome. **Doramay Keasbey**, 5031 Alta Vista Rd., Bethesda, Maryland 20814.

"PORTFOLIO OF AMERICAN COVERLETS", 19th century coverlets analyzed, photographed, documented. Looseleaf. All five volumes back in print! \$6 each postpaid. **Carol Strickler/The Textile Tree**, 1690-HA Wilson Ct., Boulder, CO 80302.

"SPINFORMATION"—by the Late Colonel Ronin, dean of spinning teachers. Prepared lessons for teaching; self-guide for beginners. Covers everything. \$13.95. **Spincraft**, P.O. Box 830332, Richardson, TX 75083.

"SPINNING AND WEAVING WITH WOOL" by Paula Simmons. This updated edition explains in detail the essentials for becoming a successful spinner and weaver. Send \$13.95 plus \$1.50 shipping. **Pacific Search Press**, Fiber Arts Dept., 222 Dexter Ave. North, Seattle, WA 98109, or call 1-800-858-0628.



North American Dye Plants The dyer's old friend, back in print. 288 pgs., p.b., illus., \$8.50 ppd.

Weeds: A Guide For Dyers and Herbalists Can anyone love a weed? 112 pgs., p.b., illus., \$6.50 ppd.

Japanese Country Weaving Introduction to the textiles of country Japan. 12 pgs., p.b., photos, \$3.50 ppd.

Dye Plant Notes Sixteen favorite illustrations from *North American Dye Plants*. Two colors on ivory stock. Two sets of eight card/envelopes. \$5.50 per set ppd.

A Mingled Yarn Thoughts from the loom, in full color. Eight different cards with envelopes. \$7.00 ppd.

Juniper House • P.O. Box 2094
Boulder, Colorado 80306-2094
Ask for our free catalog.

LITERATURE (cont.)

TEACHING FOR LEARNING, a bi-monthly newsletter for weaving and spinning teachers. For a sample copy send \$1 to **Weaving Futures**, Box 7295, Boulder, CO 80306.

"TEXTILES FOR TODAY'S CHURCH", the book containing basic information needed to begin creating liturgical textiles. Send \$8 to **Roslyn Hahn**, 706 Meadowbrook S.E., Warren, OH 44484.

"THE VIRGINIA WEST SWATCH BOOK" is the next best thing to taking a workshop with Virginia West: 20 generous swatches of 4 to 12-shaft designer fabrics, multi-purpose; limited edition; complete instructions; \$60 postpaid. **Virginia West**, 2809 Grasty Rd., Baltimore, MD 21208.

"WEAVING WITH THREE RIGID HEDDLES", by Rev. David B. McKinney. This new monograph explores four-harness weaving on the rigid heddle loom, without using pick-up sticks. Send \$6.50 plus \$1 postage and handling (CA residents add 6% sales tax). **Kuma Yarn Krafts**, Box 339, Angels Camp, CA 95222.

Create a Sensation!

featuring... The Drop Spindle
Henry's Attic... Silk City Fibers
Kathleen B. Smith (coverlet wools)
Grandor... Brittany needles
Wildwood buttons... & more!



quality yarns
& accessories
CATALOG \$1

RR 3 260 Hoffman Drive Califon NJ 07830

Desktop Weaving.

Discover AVL Weaving Software
IBM

Weave Planner. The easy-to-use software for all weavers.

Generation II. A remarkably fast and powerful program for either tie-up or dobby looms.

MAC

Design & Weave. Europe's most popular program comes to America!

Textile Designer. Just point and click. Your drawdowns appear like magic.

APPLE II

Generation II. Provides all the tools you need to create weaves up to 16 harnesses.

Design & Weave III. A command-driven program that greatly improves the design process.



Send \$2 for complete catalog.
AVL Looms
601 Orange St., Dept. H2
Chico, CA 95928

SOFTWARE

COMPUCRAFTS introduces "The Weaver" © 1983. An extremely powerful computer weaving drawdown program for the Apple II series microcomputers. Up to 8 harnesses, 10 treadles, 280 warps, 160 wefts. Features color, magnification, rising and sinking sheds, printouts of pattern and draft in traditional or counted formats. Interactive and automatic treadling. Create a data-base of designs and drafts for later review and/or modification. Send \$49.95 for disk plus manual or for complete information contact **Compucrafts**, RFD2 Box 216, Lincoln, MA 01773.

EXPAND YOUR CREATIVE HORIZONS! Discover the exciting possibilities of computer weaving with PCWeaver, the fast, friendly, flexible program for the IBM PC. 2-color PCWeaver for monochrome systems, \$49.95. 8-color PCWeaver/C for color systems, \$59.95. Order yours today! **Star Systems**, 28 Topstone Drive, Bethel, CT 06801.

PATTERNLAND WEAVE SIMULATOR 3.0™ New EGA release! 16 of 64 colors in 640x350 resolution: 224,000 pattern pixels displayed! Mixed color printing. DrawUp or DrawDown. **Weave Wizard™** weave analysis. 32 harnesses, 64 treadles, 640 warp, 800 weft. On-Line HELP and extensive printed tutorial. All IBM compatibles and printers. Money-back guarantee. \$175. **Maple Hill Software**, Plainfield, VT 05667. (802) 454-7310.

SOFTWARE FOR WEAVERS...A RESOURCE. Comprehensive reference to currently available software— invaluable! \$25. Canadian/\$20 (US) VISA. Includes current update. \$3.50 Canadian/\$2.55 US for January, 1987 update only. **Lois Larson**, 25 Montcalm Ave., Camrose, AB Canada T4V 2K9.

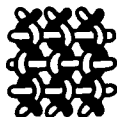

in stitches

46-305 Ikiiki Street
Kaneohe, Hawaii 96744
(808) 235-3775



Fibers, Tools & Textiles
for Weaving,
Spinning, Knitting
Classes & Workshops

The Wooden Shuttle

14 North Main Street Mullica Hill, New Jersey 08062

THE BATIK AND WEAVING SUPPLIER

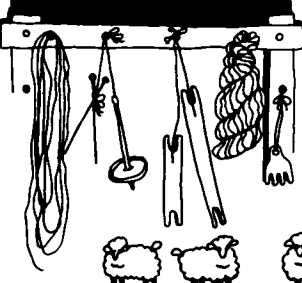

send \$1.00 for supplies catalog

COMPLETE SUPPLIES & CLASSES FOR WEAVING, SPINNING, DYEING, BATIKING & KNITTING

393 MASSACHUSETTS AVE.
ARLINGTON, MA 02174
(617) 646-4453

SUPPLIES

BASKETRY SUPPLIES, BOOKS, CLASSES. 24 page catalog—\$1.00 (refundable). **Caning Shop**, Dept. IWP, 926 Gilman St., Berkeley, CA 94710. (415) 527-5010.

ENAMELING BY KATHLEEN. Hand signed original buckles and buttons to match fiber art. Buckle shown on "Handwoven's Design Collection #9" cover. **Kathleen Miller**, 7309 Jewett Rd., Clinton, WA 98236.

MOTHPROOF PERMANENTLY. Protect your precious work. Easy to apply at room temperature to finished pieces or while you're dyeing. **PRO Chemical & Dye, Inc.**, P.O. Box 14, Somerset, MA 02726. (617) 676-3838.

NYLON EDGING. (Chiffon). Send self-addressed stamped envelope for color samples to: **Mar-Var**, 1614 E. Workman Ave., West Covina, CA 91791.

PERMANENT MOTHPROOF for wool and other protein fibers. Easily applied. One pound treats 100 lbs. \$28, directions included. MA residents add 5% sales tax. Information with **SASE. Roz Shirley**, Dept. HW, 49 Pleasant St., Medfield, MA 02052.

SHEEP ON EVERYTHING! Soap, shower curtains, pencils... more! Folkwear patterns. VHS video rental library available via UPS. Sheep print fabrics (swatches \$2) and craft ribbons (snips \$1). Latest flyers, three \$2.22 stamps. **Knots & Treadles**, 101 E. Pittsburgh St., Delmont, PA 15626.

SHIPPING FREE on all looms, wheels and equipment orders over \$50. Yarn discount program. Free brochure. Quick, careful service. **WEBS**, P.O. Box 349, 18 Kellogg Ave., Amherst, MA 01004. (413) 253-2580.

BASKETRY SUPPLIES

Books, Kits, Tools, Summer Seminar
Low Priced • Top Quality • Prompt
S.A.S.E. for FREE Catalog • Samples \$3.00



Ozark Basketry Supply

P.O. Box 56 - G, Kingston, Ark. 72742
501-665-2702

THE STORE FOR SPINNERS

Wide selection of wheels and fibers in stock.
Catalog \$2.00



Alice's Spinning Wheel

E. 8314 MT. SPOKANE PK. DR.
MEAD, WA 99021 (N.E. OF SPOKANE)
509-486-6582 by app.

THE WEAVING STUDIO

Yarn, looms, spinning
supplies, books, classes
& woven items

The Weaving Studio

812 S. Summit
Iowa City, Iowa 52240
319/338-1789

Product News

by Sharon Altergott

We recently received some equipment news from John and Laura Shannock, owners of Shannock Tapestry Looms. They will soon have available a small, collapsible frame loom with treadles that is about 2' in weaving width and moderately priced. The weaving width in their current line of upright, steel-framed tapestry looms ranges from 3' to 12'. These looms feature metal-cored roller beams to provide strength. Shannock also produces a line of solid, brass-weighted tapestry beaters. For a free brochure, write to *Shannock Tapestry Looms*, 10402 N.W. 11th Ave., Vancouver, WA 98685.



Lily Craft Products of Carlstadt, New Jersey, announces "Sprinkles" and "Mousse" – new additions to the Sugar 'n Cream family of 100% cotton yarns. "Sprinkles", available in 1.75-ounce pull skeins, is a printed, sport weight, two-ply yarn with a pearl twist, available in 12 different multicolor combinations. "Mousse" is a textured slub yarn available in nine soft fashion colors suitable for light-weight tops and baby wear. The Sugar 'n Cream family now boasts six members, all in 100% cotton; "Original" worsted weight, "Baby & Fashion" lightweight, "Sporty" sport weight, "Rug & Craft" bulky weight, and the two new offerings. Lily Craft

yarns are available at yarn shops nationwide.

New yarns from *Classic Elite Yarns* include more all-season choices. "Newport Light Cotton" is a lighter-weight version of "Newport" cotton. This 100% mercerized, prime, pima cotton comes in 21 colors. "Jasper" is a rayon and cotton yarn featuring a marled construction using black and natural filament rayon and cotton. Overdyed in 16 bright and pastel shades, this yarn has a tweed effect and blends well with "Newport Light". Another rayon blend yarn is "Memphis", a rayon/linen heathery combination. It is also available in 16 colors; its four-ply construction produces an appealing drape and hand for the weaver or knitter. Established yarns that are now available in new colors include "L.A." and "Graffiti" cotton/rayon blends. Seven different space-dyed combinations of each coordinate with the previous 18 solid shades. "Fame", a luxurious 25% silk/75% rayon variegated yarn, comes in seven different color combinations. Finally, for weavers and hand dyers, *Classic Elite* has put together a collection of natural color yarns in cotton, linen, rayon, wool and silk. These yarns are available on cones. Custom skeining for dyers is also available. Look for all *Classic Elite* yarns at your local yarn shop.

"Cocoon", a new yarn from *Silk City Fibers*, is produced by manually unreeling the unbroken fibers from intact individual silk cocoons and twisting many such fine filaments together into a pure, smooth silk yarn. Ordinary silk yarns are made by

meshing together broken or impure fibers of varying lengths and then spinning them into strands of varying thickness. This new luxury yarn comes put up in boxes containing eight 50-gram twistbales, with 165 yards per 50 grams. Look for it at your favorite yarn dealer.

Cerulean Blue's 1987 catalog has just been printed. This catalog is more than just a price list. Along with basic descriptions, prices and technical information, the text covers safety precautions, alternate applications, adaptations for production studio and school use, and photos of artwork made with the products. For your copy of this 56-page catalog send \$3.50 check or money order (U.S. funds) to *Cerulean Blue, Ltd.*, P.O. Box 21168, Seattle, WA 98111-3168.

The 1987 *Folkwear* home catalog has also appeared, featuring fashions from khaki and lace safari gear through "Recently Retro" '40s and '50s glamour and individual art-to-wear. Look for the catalog at over 1200 fabric shops nationwide or send \$1 directly to *Folkwear Customer Service*, P.O. Box 3859, Dept. FC, San Rafael, CA 94912.

Penland School's premier issue of the "Penland Journal" contains an overview of the school's history, philosophy and facilities along with a comprehensive listing of all classes offered for summer 1987. The journal will be published three times a year and sent to all Friends of Penland School; a copy of the current issue may be obtained for \$3.50 (including postage and handling) from *Penland Journal*, Penland, NC 28765. □

GRANDOR introduces

Effekta yarns

Heavy wool & wool/rayon yarns
(up to 3/4" diameter in exciting new fashion colors)
Weaves very fast.

For RUGS, WALL HANGINGS, ROOM DIVIDERS,
SADDLE BLANKETS, JACKETS, ART PIECES.

Sample cards for heavy yarns only \$4.50
Wholesale to the trade.

GRANDOR INDUSTRIES, LTD.

716 E. Valley Parkway, Unit 48H
Escondido, CA 92025 • (619) 743-2345

Beck's

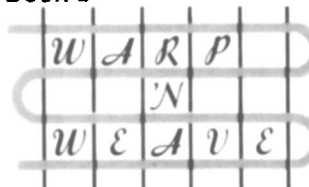

& Needlecrafts

2815 34th
Lubbock, TX 79410
806-799-0151

YARNS-SUPPLIES-
TOOLS
HUNDREDS OF
BOOKS

COTTONS,
WOOLS,
MILL ENDS

Quantity/Bulk Discounts
Catalog & samples, \$1.00

Reflections on 7560 Weft Picks

by Linda Ligon

OF COURSE I already have a basement full of yarn. Of course I believe that you should plan what you're going to make before you buy your yarn. Of course. So why did I end up with these two strange cones of impossibly fine wool in odd shades of green? Because they were gorgeous. And why did they sit on my shelf for four years? You know.

I bought the yarn, and looked at the yarn, and thought about the yarn, and procrastinated, until my better self finally got a word in there and made me plunge in. It's a 40/2 worsted – over 11,000 yards per pound – available occasionally as a mill end from such suppliers as Robin & Russ or Greentree Ranch Wools, or perhaps from your local weaving shop. It makes a lovely, sheer, fabric; I've seen it set successfully at 24 e.p.i. for a gauzy shawl up to 40 e.p.i. and more for a crisper, more substantial dress-weight cloth. I decided on 30 e.p.i. for a soft, sheer blouse, and started measuring those little bitty yarns.

It was at this point that I decided to play a numbers game to keep from feeling overwhelmed. Thirty e.p.i., 24" wide, is after all only 720 ends. Measure them two at a time, and it's only 360 passes on the warping board. Ten seconds per pass, and you're only talking an hour of warp-measuring time. Thoroughly possible!

I warped from the back, which is important with this yarn. The warp as a mass of threads is plenty strong, but each individual thread is pretty fragile. You wouldn't want to drag the whole length through the heddles. Threading, like measuring, was not the infinite task my mind had made it seem. Five seconds per end is only an hour of threading time. I didn't do it all in one sitting, but gave myself little breaks after every few inches.

My threading was a spot Bronson arranged in little chevron patterns, a nifty pattern from *Versatile Bronson* by Dorothy S. Burton.¹ The only tricky thing about it is that *half* your

heddles are on a single harness. I had to spend some time shifting heddles around before I started threading; not my favorite job – but definitely something you have to plan ahead for. Below is the threading I used, and a four-shaft version that I think would be very nice.

Now, I have to confess that I got carried away when I measured my warp. You don't really *need* seven yards of cloth for a blouse, at least not my kind of blouse, but I wanted to use that yarn up once and for all. When it came time to actually weave, my kitchen timer gave me fortitude. Thirty picks per inch, three seconds per pick – hey! Theoretically I was weaving a yard every 54 minutes! Actually I was stopping every little while to wind a bobbin (300 revolutions at half a second each) or reward myself with a coffee break. The point is, it just wasn't that terrible timewise, and it was a lot of fun to weave. I found odd hours here and there over a couple of weeks, and there it was.

In case you're hoarding a similar kind of yarn, let me share some practical pointers and pitfalls.

- As fragile as the yarn looks, I experienced no warp breakage at all, except at knots. Don't leave knots in your warp.
- Spot Bronson, a block weave, gives you some latitude in your treading. I started out weaving the chevrons one right after the other, then started gradually spacing them out with



Fine wool fabric in spot Bronson woven by the author.

tabby in between, and ended up with an accent fabric for facings and such that uses only blocks two and six with a lot of plain weave in between for a polka-dot effect. Lots of other possibilities.

• The main thing that prevented me from weaving off the whole seven yards in one Saturday was my backside. After an hour or so of rocking back and forth on my ischeal tuberosities, or buns if you will, I was ready to *die*. If you weave yardage in long, vigorous sessions and have found a solution to this problem, please let me know. Do you have a comfy loom bench? What kind is it? Do you have a special way of arranging yourself? Or am I the only weaver who gets leg aches from pursuing my craft?

So that's the story of my cloth, all 7560 weft picks of it. The only anxiety left on my yarn shelf – well, almost the only one – is a cone of breathtaking 62/1 linen . . .

¹Published by the Boston Weavers Guild; \$7.00 ppd. from Mrs. G.C. Goodband, 361 Norwood Street, Sharon, MA 02067.

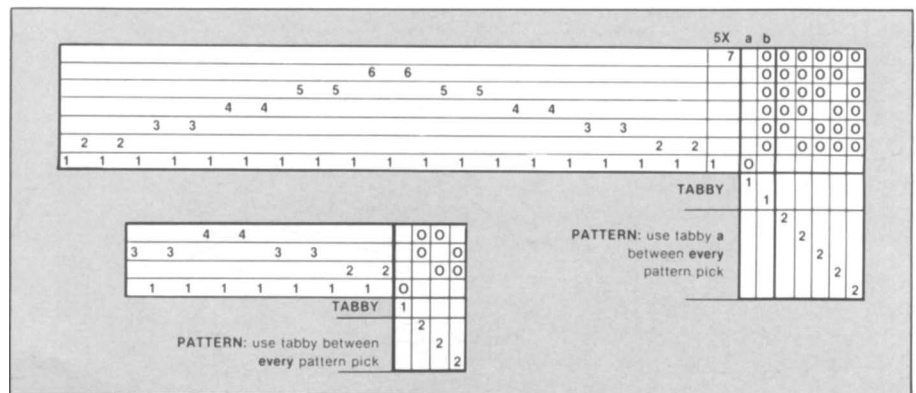

A Glimakra Studio
The Spinnery

Spinning - Weaving
 Dyeing - Classes - Supplies

**FREE
 Vintage Yarn
 Samples**

Beautiful - hand dyed
 mohair & wool
 Eight delicious colors
 A feast for the eyes

Exclusive from
The Spinnery

RD 2, Box 156
 Route 202 North
 Neshanic Station, NJ 08853
 201-369-3260

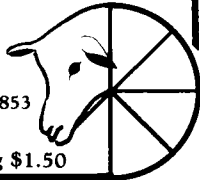

Catalog \$1.50

The Mariposa Tree Line

Cashgora, Mohair, Merino
 from Australia
 Cashmere, Silk, Angora, Alpaca
 and Wool fibers
 Cashmere/Silk & Silk/Wool Rovings
 Ashford Wheels - Mark IV Drum Carders
 Tapestry, Sample & Inkle Looms
 E'Lite Yarns
 Brittany Walnut Knitting Needles
 Natural Dyes - Cushing Dyes
 And More!

Send \$1.00 for brochure to:
 The Mariposa Tree, Inc.
 P.O. Box 336
 Staten Island, New York 10304

HANDWOVEN

It's worth saving!

HANDWOVEN has been your catalyst for fine weaving over the past decade. Information, inspiration - interwoven. Protect your collection of back issues with clean, orderly and readily accessible cases and binders.

Handsome cases and binders are custom-made for us in dark blue leatherette, embossed with gold leaf lettering. Each holds ten issues.

CASES: \$7.95 each: 3 for \$21.95; 6 for \$39.95.
 BINDERS: \$9.95 each: 3 for \$27.95; 6 for \$52.95.

Send to: Handwoven, Jesse Jones Industries, Dept. HW, 499 E. Erie Ave., Philadelphia, PA 19134.

Enclosed is \$_____ for _____ Cases; _____ Binders. Add \$1 per case/binder for postage & handling. Outside USA \$2.50 per case/binder (US funds only). PA residents add 6% sales tax. NO P.O. BOXES, PLEASE.

Name _____

Address _____

City _____

State _____ Zip _____

Charge orders (minimum \$15): Am Ex, Visa, MC DC accepted. Send card name, #, Exp. date. Call toll-free 7 days, 24 hours 1-800-972-5858. Satisfaction Guaranteed!

GARAGE SALE

SAVE BIG on returned books with scuffed covers, dog-eared issues of *Handwoven* and *Spin-Off*, calendars that didn't quite sell out and more! All partially damaged merchandise must GO!!!

For a complete listing of what's available, send us a long SASE. Many of the older items are in short supply, so act NOW!

 INTERWEAVE PRESS GARAGE SALE
 306 N. Washington Ave.
 Loveland, CO 80537

MOVING?

Make certain that **HANDWOVEN** follows you to your new address. Send both old and new addresses along with your customer number that appears on your mailing label to:

Handwoven/Change of Address

306 N. Washington Ave.

Loveland, CO 80537

please allow six weeks notice. Thank!

MOUNTAIN LOOM

Company, Ltd.

P.O. Box 182 • Curlew, WA 99118
 (604) 446-2509

Four-Harness Sampler Loom

\$44

(plus postage)

Eight-Harness Sampler Loom

\$65

(plus postage)

Full 12" weaving width
 Maplewood construction
 Beautiful hand-rubbed oil finish
 Reed and heddles not included
 Steel reed 2-30 dents/inch \$15
 Texsolv heddles—\$8/hundred

Shipped assembled

Free Brochure
 100% money-back guarantee

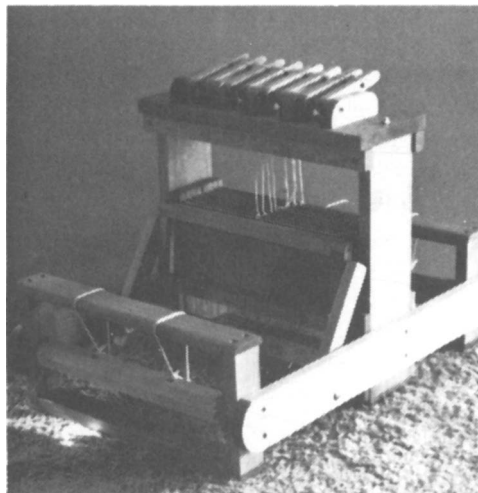

**WIN A
 FREE LOOM**

An 8-harness Sampler Loom will be awarded each month for the best advice offered in reply to the following question:

"I WOULD LIKE TO BUY A LOOM BUT HOW CAN I CONVINC MY HUSBAND?"

Results & winners to be published in subsequent issues. Send entries to Mountain Loom Co., Ltd., P.O. Box 182, Curlew, WA 99118.

Canadian Mail Order "WEAVING YARN"

Offering a large selection of WEAVING YARN:
Cotton—Polyester—Orlon—Linen—Boucle—Silk
All available in several colors at unbeatable prices

AGENT FOR
Lamieux Yarn (100% wool) • Nilus Leclerc Loom
— FREE Price List —

Send \$7.95 (U.S. Res. send \$9.95) for complete samples & price list to:



MAURICE BRASSARD ET FILS INC.

1972 Simoneau
C.P. 4
Plessisville, Quebec
Canada G6L 2Y6

TREENWAY CRAFTS LTD.



Our SILK yarn is available in
36 hand-dyed colours.
Samples & price list \$3.00



Catalogue containing complete
line of products \$3.00
Mail order only.

Treenway Crafts Ltd. 3841 Duke Road, RR 1,
Victoria, British Columbia, Canada V8X 3W9
Telephone: (604) 478-3538

J & D Highland Imports

presents
*Fine Woolen Weaving Yarn
from Scotland*
Perfect for Tartans and Tweeds

Send \$2.00 for sample cards (refunded with first order).
P.O. Box 636 • Occidental, CA 95465-0636

SPECIALIZING IN WARP BY DIRECT MAIL SAMPLES \$2.00



P.O. BOX 2520 • (707) 763-YARN
PETALUMA, CALIFORNIA 94953



ADVERTISERS' INDEX

Alice's Spinning Wheel	96	Fallbrook House	95	Locc's Yarn Co.	94	Southwest Craft Center	87
Alliance Trading Co.	83	Fiber Forum	92	Looms, The	86	Special Products Co.	92
Arrowmont School	87	Fiber Studio	22, 84	Louët Sales	19	Spin 'n Weave	88
Aussie Yarns	79	Fibercraft Imports	75	Macomber Sales	22	Spinnery, The	99
AVL Looms	96, bc	Ft. Crailo Yarns	28	Mannings	86, 94	Spinning Shop & Coverlet Co.	80
Ayottes' Designery	79	Friendship Farm Handweaving	86	Mariposa Tree	99	Spring Creek Farm	92
Bare Hill Studios	84	Gilmore Looms	10	Mountain Loom Co.	99	Stuff	96
Batik & Weaving Supplier	96	Glimåkra Looms	4, 5, 9, 13, 26	Natural Fibers Only	94	Sweater Workshop	93
Beck's Warp 'n Weave	97	Golden Heddle	85	No. Vermont School of	95	System Texsolv AB	5
Blomqvist, C.L.	24	Gorrie Downs	94	Fiber Arts		Tewa Weavers	95
Bollweavel's	85	Grandor Industries	97	Norwood Looms	24	Texas Fibers	94
Bradshaw Manufacturing	84	Great Northern Weaving	92	Novitex	25	Treenway Crafts	100
Brassard, Maurice & Fils	100	Green, Patrick	93	OR Rug Co.	85	Tunstede	11
Brown Sheep Co.	20	Greentree Ranch Wools	31, 87	Ozark Basketry	96	Väv Magasinet	13
California Colors	92	Halcyon	6	Pendleton Shop	88	Victorian Video	88
Charlie's Longhorn Weavers	95	Haliburton School of Fine Arts	86	Penland School	87	Village Weavers	80
Classic Elite Yarns	29	Handcraft Wools	76	Plymouth Yarn Co.	81	Warp Ways	85
Cotton Clouds	24	Harrisville Designs	12, 76	Rigby Cloth Stripping	93	Warped Weaver	100
Country Craftsman	31	Heirloom Linens	92	Rio Grande Weaver's Supply	83	Weaver's Journal	90
Spinning Wheel		Heite, Louise	29	River Farm	82	Weaver's Knot	85
CrossRoads	88	Hillier, Lydia	89	Riverwalk Yarns	94	Weavers' School	86
Crystal Palace Yarns	31, 82	Hochberg, Bette	95	Scancraft	76	Weavers' Store	85
Daft Dames	93	Holma-Helsingland AB	80	Schacht Spindle Co.	14-17, 22	Weavers' Warehouse	92
Davidson's Old Mill Yarn	85	Ihana Brushing Service	75	School Products	75	Weaver's Way	7
Dorset Looms	85	In Stitches	96	Schoolhouse Yarns	80, 90	Weaving Studio	96
Dos Tejedoras	82	Interweave Press	21, 30 99, ifc, ibc	Scottish Studies Program	86	Webs	92
Drop Spindle	82	JaggerSpun	3	Scott's Woolen Mill	20	Whitaker, Gerald	82
Dyakit	92	J & D Highland	100	Searles, Nancy	76	Wilde Yarns	76
Eaton Yarns	90	Jessie Jones	99	Serendipity Shop	82	Windover Wools	76
Edgemont Yarn Service	75	J-Made Looms	88	Siever's Looms	87	Wooden Shuttle	96
Egen Weaving	95	Juniper House	95	Silk City Fibers	8	WoodsEdge Wools	95
		Kalamitsi, Katerina	95	Silk Tree	23	Wool Gallery	83
		Kessenich Loom	93	Smith & Ewe	93	Yarn Barn (Kansas)	91
		La Lana Wools	95	Something Extra Special	89	Yarn Barn (Maine)	87

NEW



Terrific Table Toppers

INTRODUCING Handwoven's Design Collection 10. Thirteen irresistible weaving patterns for pretty and practical table runners, mats, cloths and napkins.

Festive, contemporary, traditional, fun. **Terrific Table Toppers** has something for you. Order yours today, and have a happy weaving summer.

Available in June at your local weaving shop or from Interweave Press, Inc., for \$4 (plus \$2 postage/handling). Or order any five of Handwoven's Design Collections for \$18 (plus \$2.50 postage/handling).

To order, please refer to the Book Order Insert inside this issue of Handwoven.

DETAILS, DETAILS, DETAILS

Introducing AVL's New Technical Dobby Loom

It isn't easy dealing with perfectionists.

Some other engineers would have cut corners and cranked out a 20 harness Countermarche Dobby Loom in no time.

But not our group.

They spent over three years taking care of the details. The little things, the unnoticed technicalities, that make the difference between a good loom and a truly great one. Every time the rest of us were ready to unveil the loom, they wanted to do some more fine tuning.



Pulleys, cams and bushings - meet the hidden reasons all twenty harnesses move with ease on every beat. They're only some of the details that helped make a good loom a great one.

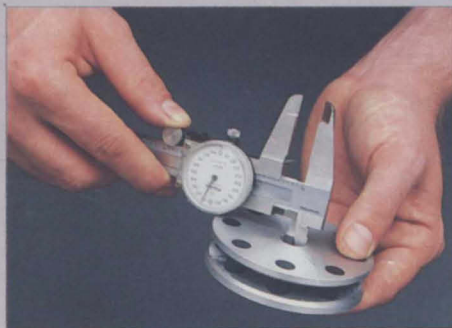

So the development effort went on . . . and on . . . and on. New details, new parts, new ideas - all with one driving obsession: To build a loom like no other.

And the result? Something spectacular. The AVL Technical Dobby Loom.

The Technical Dobby Loom is indeed a loom that doesn't cut any corners. The unprecedented Countermarche Dobby Head yields the classic, perfect shed with none of the hassles normally associated with typical countermarche looms. Just think - no tie-ups!

And twenty harnesses? The cam-assisted action is so easy they can be opened with your index finger on the treadle. Really.

And all without forgetting the details. Bronze bushings that mean less friction for easy action. Special aircraft cable that just won't break. And hundreds more.



We spent hundreds of hours perfecting the unique twin-arm countermarche dobbie system that eliminates the need for tie-ups.

Details on a loom designed by perfectionists for . . . well, perfectionists like you.



**AVL
LOOMS**

601 Orange St.
Dept. 602
Chico, California
95928

Call us at
(800) 626-9615
or inside California
(916) 893-4915

Send \$2 for complete
catalog.

AVL. Now the possibilities are endless.