

# Hydrozone™

## — Technical Information Pack



**Vortex™**  
**Spas**

Available exclusively at *Spa* WORLD

# Hydrozone™



JETS

Up to 68



VOLUME

Up to 7,300 litres



SEATING

Up to 7 seats



DIMENSIONS

5.90 x 2.30 x 1.3/1.5m



## FEATURES

### Build

- Step down access
- Superior USA made Aristech™ acrylic
- Thermobond™ 4 layer shell construction
- 9 shell/cabinet colour combinations
- Galvanised steel frame construction
- Duraflex™ 'no kink' PVC plumbing
- Aromatherapy system
- Thermoclad™ maintenance-free cabinet

### Water care

- Purezone™ micro filtration
- Purezone™ CD Ozone water clarifier

### Lighting

- Hydroglow™ underwater LED floodlight

### Control

- SpaNet™ premium control systems
- Spa Health indicator

### Hydrotherapy

- Individual seat pressure controls
- Neck therapy collar
- Hydrotherapy lounger

### Optional Upgrades Included in Avanté

- Purezone™ UV-C Sanitizer
- ThermoLock™ Dual layer insulation
- Hydroglow™ programmable lighting
- Hydroflow™ stainless steel bearing-less jets
- Hydroglow™ LED backlit water cascade
- Hydroglow™ jet & topside control lighting
- Hydroglow™ perimeter & cabinet lighting
- Hydroglow™ backlit drink holders
- Hydroglow™ backlit laminar jets

### Optional Extras

- SmartLINK™ Wifi connectivity
- SmartSTREAM™ sound system
- SpaNet™ Hybrid heat pump
- AquaSal™ automatic sanitiser

## WARRANTIES

Frame .....	Lifetime
Shell structure.....	10 yrs
Acrylic surface .....	5 yrs
Jets, plumbing & heater .....	5 yrs
Pumps & equipment .....	2 yrs

\* Conditions apply. Specifications may change without notice. Pictures may show options not available on all models.

# Hydrozone™

Height comparison

---

## Hydrozone™

Dimensions: 5.90 x 2.30 x 1.3m

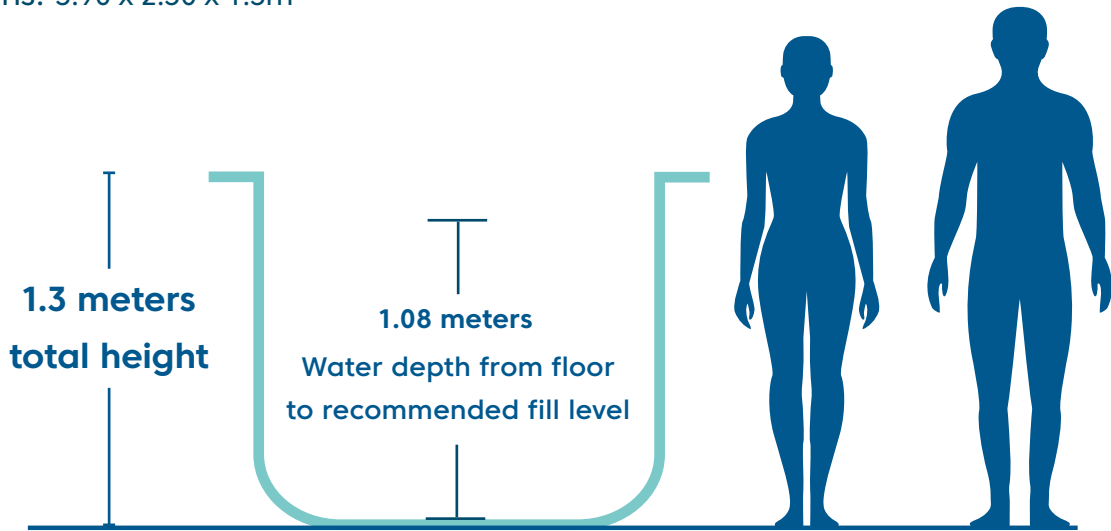

## Hydrozone XD™

Dimensions: 5.90 x 2.30 x 1.5m

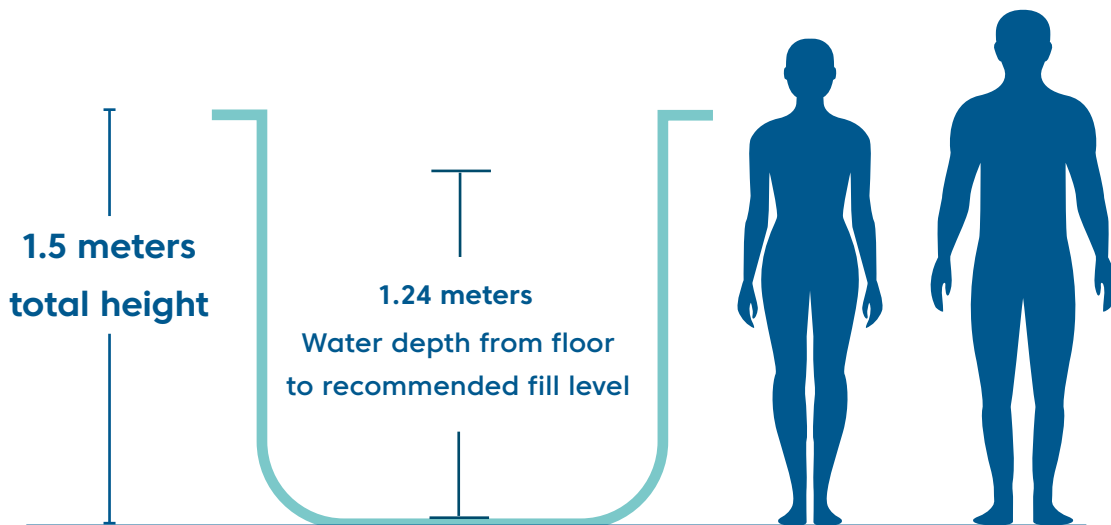

# Hydrozone™

## Jet specifications

Dimensions: 5.90 x 2.30 x 1.3m

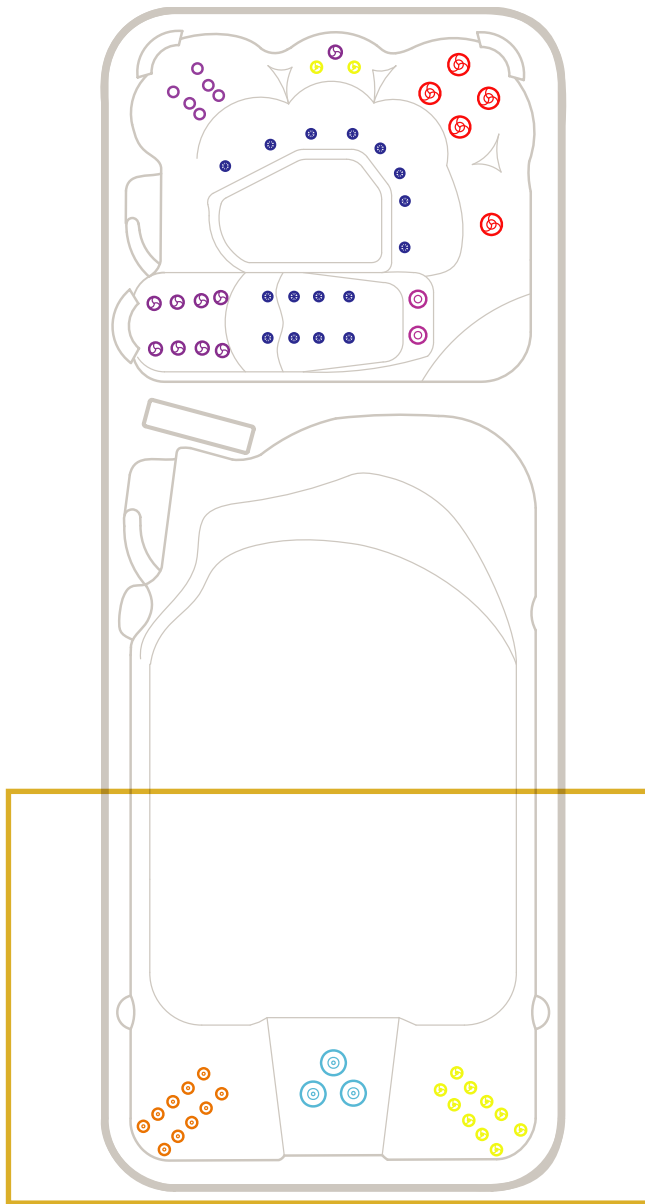

Illustration shows our most popular swim spa Hydrozone Pro+™ model.

 127mm Single Spinning Jets

 127mm Directional Jet

 75mm Directional Jets

 75mm Single Spinning Jets

 50mm Directional Jets

 50mm Twin Spinner Jets

 40mm Air Jets

### Hydrozone Plunge™

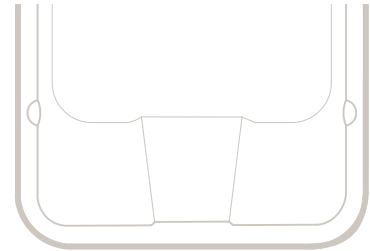

### Hydrozone Pro™

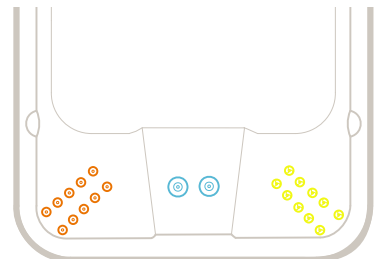

### Hydrozone Pro+™

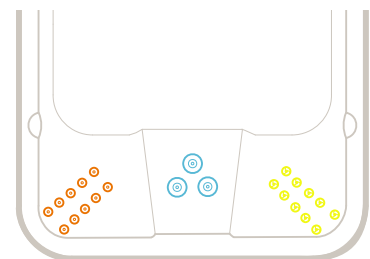

### Hydrozone Extreme™

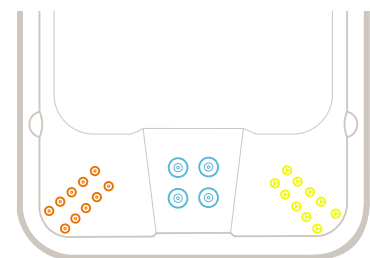

 150mm Swim Jets

\* Conditions apply. Specifications may change without notice. Pictures may show options not available on all models.

# Hydrozone XD™

## Jet specifications

Dimensions: 5.90 x 2.30 x 1.5m

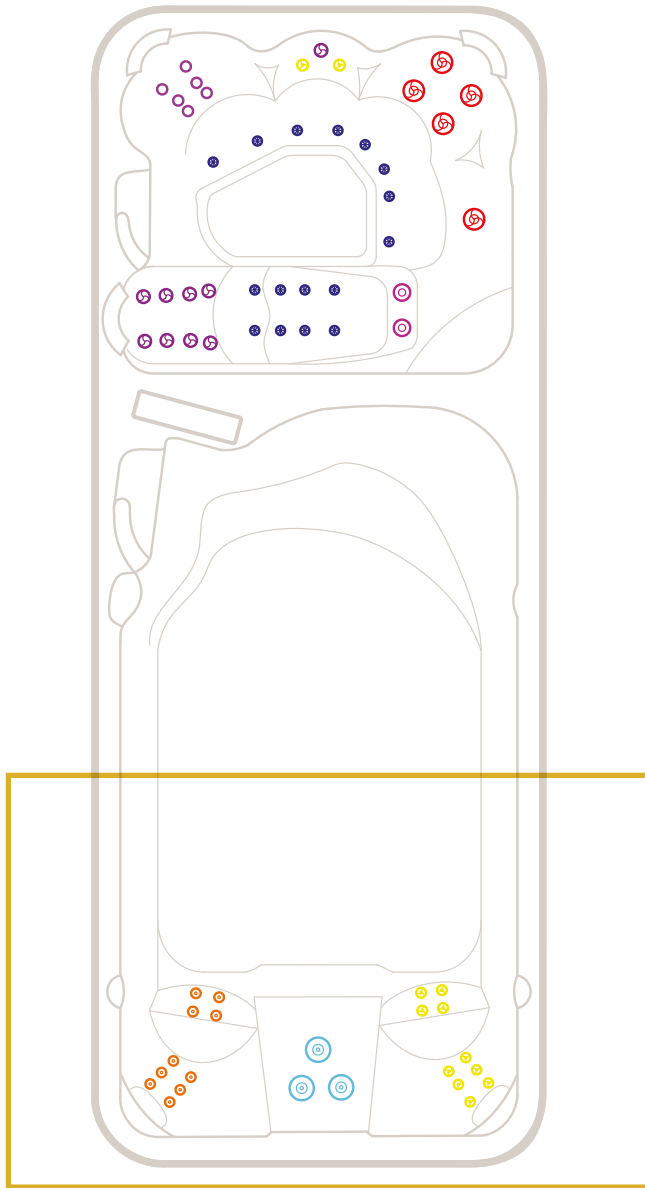
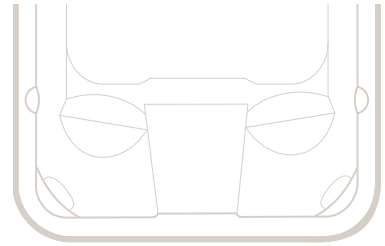

Illustration shows our most popular swim spa Hydrozone Pro+ XD™ model.

-  127mm Single Spinning Jets
-  127mm Directional Jet
-  75mm Directional Jets
-  75mm Single Spinning Jets

-  50mm Directional Jets
-  50mm Twin Spinner Jets
-  40mm Air Jets

### Hydrozone Plunge XD™



### Hydrozone Pro XD™

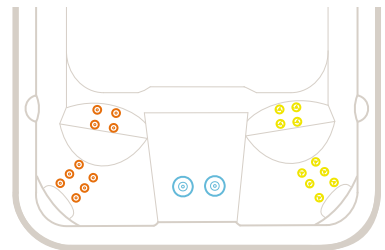

### Hydrozone Pro+ XD™

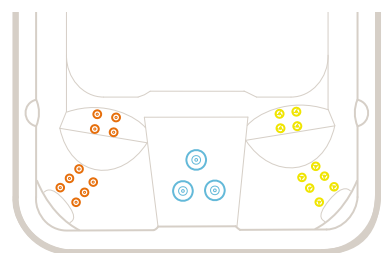

### Hydrozone Extreme XD™

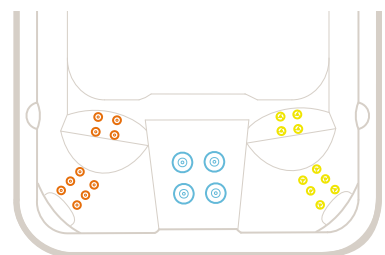

-  150mm Swim Jets

\* Conditions apply. Specifications may change without notice. Pictures may show options not available on all models.

# Hydrozone™

## Specifications table

		Plunge	Pro	Pro Plus	Extreme
<b>Dry weight</b>					
Hydrozone™	1.3m	1,380kg	1,431kg	1,480kg	1,530kg
Hydrozone XD™	1.5m	1,450kg	1,500kg	1,531kg	1,580kg
<b>Filled weight (incl cover)</b>					
Hydrozone™	1.3m	8,122kg	8,173kg	8,222kg	8,272kg
Hydrozone XD™	1.5m	8,808kg	8,858kg	8,889kg	8,938kg
<b>Lift weight</b>					
Hydrozone™	1.3m	1,900kg	1,900kg	1,900kg	1,900kg
Hydrozone XD™	1.5m	2,000kg	2,000kg	2,000kg	2,000kg
Intuitive spa controller		SV2 + SV2	SV2 + SV3	SV2 + SV3	SV2 + SV4
Programmable circulation pump		1	1	1	1
Jet pumps		1 + 1	2 + 1	3 + 1	4 + 1
Variable speed air blower		1	1	1	1
Variable output heater		3kW + 3kW	3kW + 5.25kW	3kW + 5.25kW	3kW + 5.25kW
Recommended electrical supply		15 + 15 amps	15 + 32 amps	15 + 32 amps	15 + 40 amps

\* Conditions apply. Specifications may change without notice. Pictures may show options not available on all models.

# Hydrozone™

## Equipment location

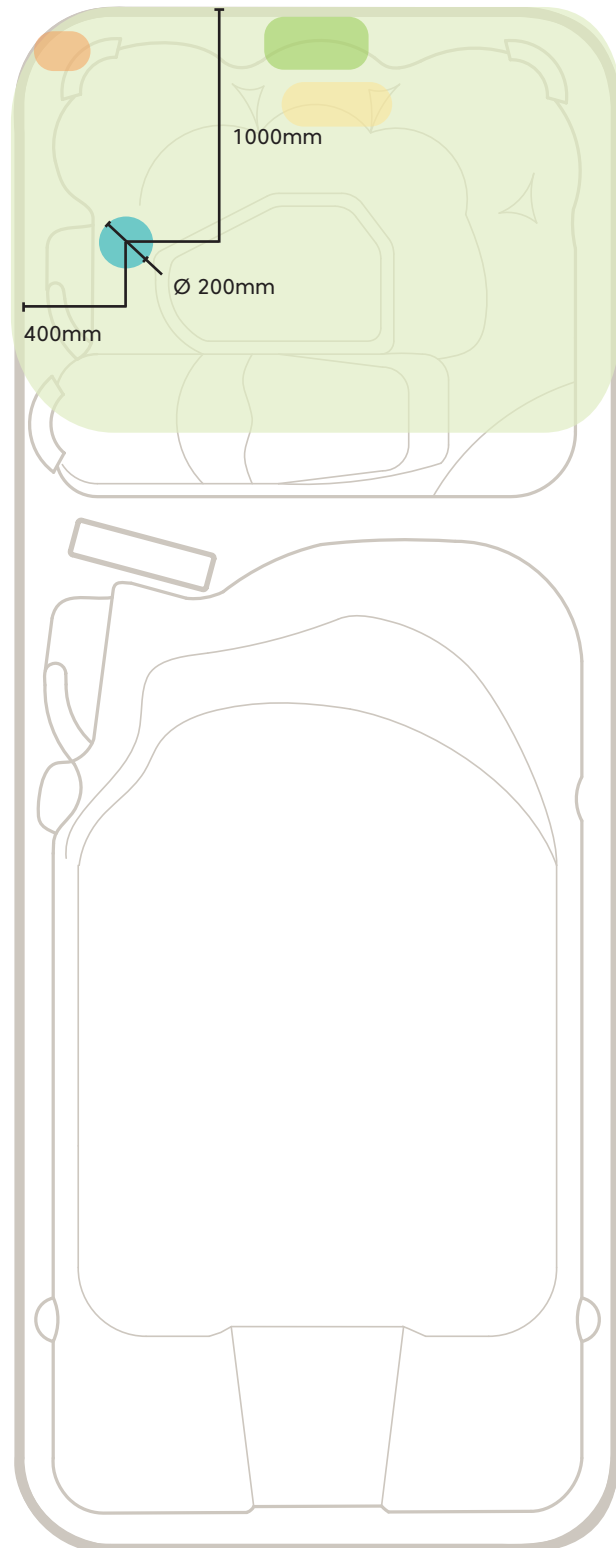
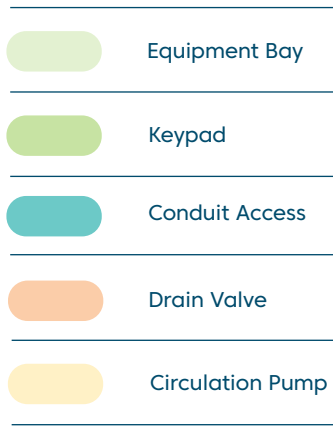

\* Conduit access should be no more than 100mm high above the concrete slab.

**Note:** This model has a rigid base, and if you choose to bring the piping conduit in from the bottom through the base, you will need to cut a hole into the base on-site before installation. The factory does not provide this hole. Please see the diagram above to find the location where you can drill the hole.

Illustration shows Hydrozone™ 1.3m swim spa model

# Hydrozone™

## Standard Spa Cover

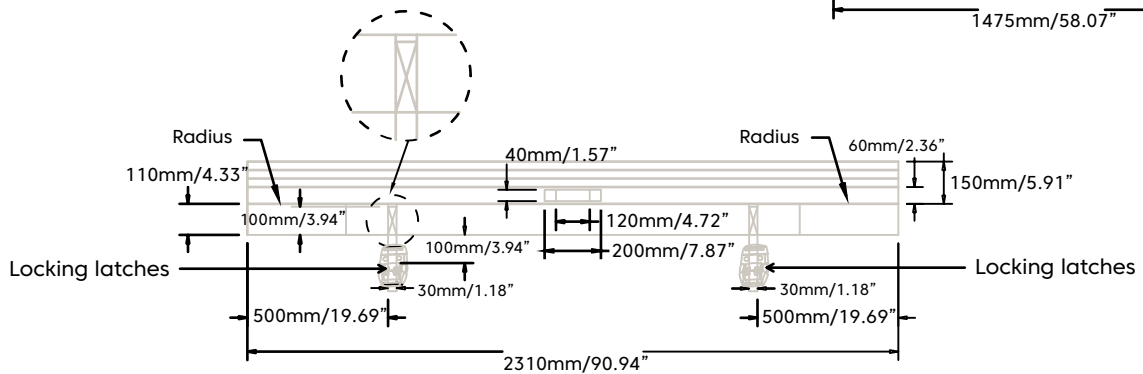
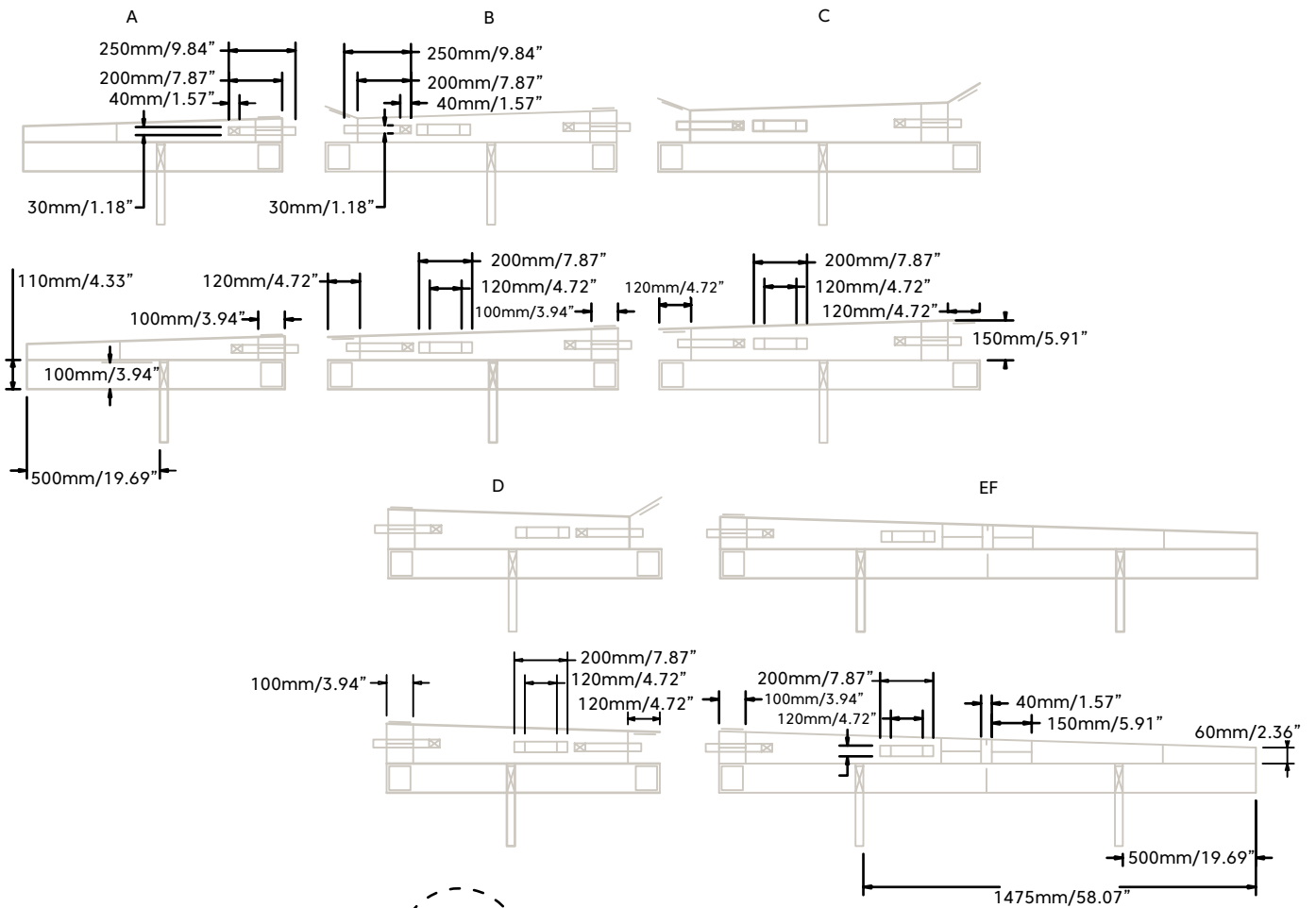
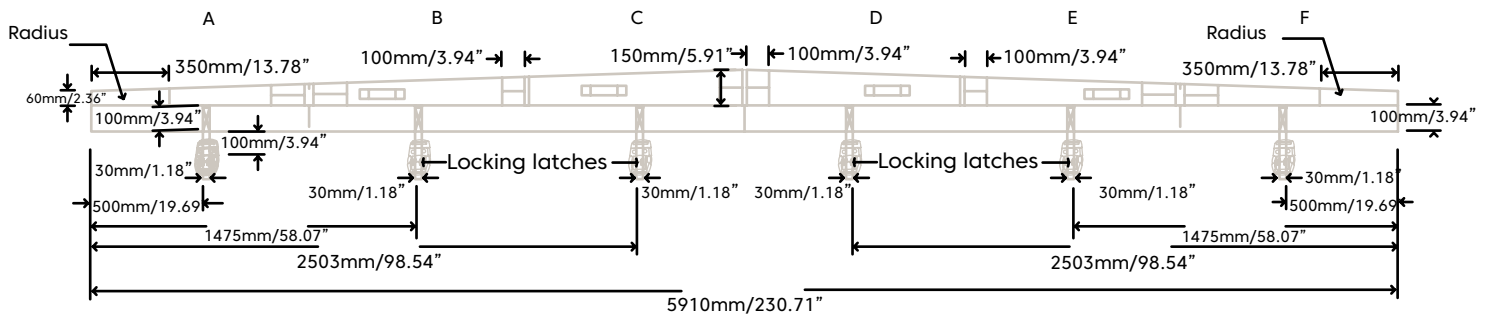



# Hydrozone™

## Planning details

---

Please visit the Spa World website for planning information including:

Property access

Electrical Information

Service access

Foundations, including generic slab

Pit and deck installation

Optional heat pump installation

Use your Smartphone to scan the QR code for your country:

Australia  
[spaworld.com.au](http://spaworld.com.au)



[Click here to find out more](#)

New Zealand  
[spaworld.co.nz](http://spaworld.co.nz)



[Click here to find out more](#)

# Vortex Spas™ Limited Warranty

Vortex Leisure Pty Ltd owns the Vortex Spas™ brand

## Lifetime Warranty on Permaframe™ Frames

Vortex Leisure Pty Ltd warrants the structural integrity of the spa frame against defects in workmanship and materials for the lifetime of the spa subject to the limitations, conditions and exclusions expressed in this warranty.

## 10 year non pro rata structural warranty

Vortex Leisure Pty Ltd warrants the structure of the spa shell against defects in workmanship and materials leading to water loss from the spa for a period of 10 years from date of manufacture subject to the limitations and conditions expressed in this warranty.

## 5 year acrylic warranty

Vortex Leisure Pty Ltd warrants against the loss of water through the acrylic surface of the spa shell for a period of 5 years from date of manufacture, subject to limitations and conditions in this warranty.

## 5 year jet warranty

Vortex Leisure Pty Ltd warrants the removable spa jets to be free of manufacturing defects for a period of 5 years from date of manufacture. This warranty excludes damage by grit, sand and improper water chemistry causing corrosion of the part and is limited to supply of replacement parts after the faulty part has been returned to Vortex Leisure Pty Ltd for warranty inspection. Leaking from jets is covered by the plumbing warranty. Laminar jets have a 1 year parts only warranty.

## 5 year heater warranty

Vortex Leisure Pty Ltd warrants the heater element against defects in materials and workmanship for a period of 5 years from date of manufacture. After 1 year this warranty is limited to the supply of replacement parts and excludes labour and freight costs. This warranty does not cover damage to heaters caused by incorrect water balance resulting in the heater being subjected to abrasive/acid water.

## 5 year plumbing warranty

Vortex Leisure Pty Ltd warrants the plumbing piping and plumbing joints against defects in materials and workmanship causing leaking for a period of 5 years from date of manufacture. After 1 year this warranty is limited to the supply of replacement parts and excludes all labor and freight costs.

## 2 year pump warranty

Vortex Leisure Pty Ltd warrants the water pumps against defects in materials and workmanship for a period of 2 years from date of manufacture. After 1 year this warranty is limited to the supply of replacement parts and excludes all labour and freight costs. Damage to the pump motor caused by incorrect chemical balance will not be covered under this warranty. Vortex Leisure Pty Ltd reserves the right to request that the pump be returned for assessment before it is replaced under this warranty.

## 2 year electronic components warranty

Vortex Leisure Pty Ltd warrants electronic control systems against defects in materials and workmanship for a period of 2 years from date of manufacture. After 1 year the warranty is limited to the supply of replacement parts after the product has been assessed by either Vortex Leisure Pty Ltd or the relevant control system manufacturer.

## 1 year air blower warranty

Vortex Leisure Pty Ltd warrants the air blower against defects in materials and workmanship for a period of 1 year. This warranty will become void if the blower damage is caused by overfilling.

## 1 year thermoclad cabinet warranty

Vortex Leisure Pty Ltd warrants the thermoclad spa cabinet against defects in materials and workmanship for a period of 1 year from date of manufacture. This warranty specifically covers the structural integrity of the cabinet. The thermoclad cabinet finish is warranted to be free from defects in materials and workmanship at the time of initial delivery. Fading and weathering of the surface will occur naturally over time, and are not considered defects.

## 1 year Wifi, audio system, ozone, UV, LED light(s) warranty

Vortex Leisure Pty Ltd warrants the factory installed Wifi, audio system, UV sanitiser, Ozone sanitiser and LED Light(s) assemblies, to be free from defects in materials and workmanship for 1 year. The UV globe is a parts only warranty, if it fails within the 1 year period, a replacement globe will be sent out free of charge to be installed by the customer.

## 1 year external heat pump warranty

Vortex Leisure Pty Ltd warrants the External Heat Pump to be free from defects in materials and workmanship for 1 year. Installation is to be carried out by a qualified contractor. Failure to do so will immediately VOID this warranty. Vortex Leisure Pty Ltd reserves the right to request the return of the heat pump for assessment before it is replaced or repaired.

## 1 year spa hardcover warranty

Your Spa Cover is warranted for a period of 1 Year from the date of delivery. This warranty applies only to the structural integrity of the cover and the vinyl. Damage caused to stitching, straps or locks due to improper use of the cover will not be covered under warranty. Disposal of any cover replaced under warranty will be the owners responsibility.

## Warranty coverage

Warranty coverage begins at the delivery date. Vortex Leisure Pty Ltd only extends this warranty to the original purchaser and only if the spa has been purchased through an authorized Vortex Leisure Pty Ltd reseller. Written notice of the defect and proof of purchase must be provided to Vortex Leisure Pty Ltd or it's nominated representative within 14 days of the defect occurring. If the spa is required to be returned to Vortex Leisure Pty Ltd for rectification all freight costs shall be pre paid by the customer. Repair or replacement of any defective product is at the sole discretion of Vortex Leisure Pty Ltd. To action warranty service contact the authorized Vortex Leisure Pty Ltd reseller you purchased from. If you are unable to obtain satisfactory service from your reseller, written notification must be provided to Vortex Leisure Pty Ltd within 14 days of the defect occurring. Vortex Leisure Pty Ltd will pay the travel costs of the service agent for the first 50km from their base. Any further travel charges shall be the responsibility of the spa owner.

## Electrical connection

All electrical connections must be carried out by a qualified electrical contractor. Failure to do so will immediately VOID this warranty. The spa must be connected to a dedicated MAINS electrical supply circuit protected by a compliant earth leakage circuit breaker safety switch. Vortex Leisure Pty Ltd reserves the right to ask for proof that the spa has been installed by a qualified electrician.

## Warranty exclusions

1. Damage resulting from improper water maintenance.
2. Damage from operating the spa above 45°C.
3. Damage caused by clogged filters
4. Damage caused to the spa by improper use of spa cover and excessive exposure to sunlight.
5. Acts of God.
6. Damage caused by not installing spa on sufficient hard level surface.
7. Damage caused by incorrect electrical installation, brownouts, voltage spikes or operating spa out of +/- 10% of voltage range.
8. Warranty is not extended to filter cartridges, head rests, pump seals or drain hoses.
9. Commercial use reduces all warranties to maximum 6 months.
10. Damage caused by relocation of the spa from its original installed location.
11. Damage by termites, borer or other pests.
12. Damage caused by flooding
13. Damage caused by third party carriers.
14. Damage or corrosion to frame caused by un-repaired leaks or improper drainage.

## Limitations

This warranty is the only warranty offered by Vortex Leisure Pty Ltd and excludes any other implied or oral undertakings. Except as described above, this warranty does not cover defects or damage due to normal wear and tear, improper installation, alteration without Vortex Leisure Pty Ltd's prior written consent, accident, acts of God, misuse, abuse, commercial or industrial use, use of an accessory not approved by Vortex Leisure Pty Ltd, failure to follow Vortex Spas™ Pre-Delivery Instructions or Owner's Manual, or repairs made or attempted by anyone other than an authorized representative of Vortex Leisure Pty Ltd. Vortex Leisure Pty Ltd or its agents will not be liable for any incidental or consequential loss or injury. Vortex Leisure Pty Ltd will not be liable for costs associated with but not limited to building alterations, removal costs, delivery costs or labour costs associated with the replacement of a spa.

You must check and tighten all barrel unions regularly. Failure to do so may affect your warranty.  
See your user manual for further information.

VSW030821



# Vortex

# Hydrozone<sup>TM</sup>

# Plumbing Approval

**Building Act 1993**  
*Section 238(1)(a)*  
**Building Regulations 2018**  
*Regulation 126*

**CERTIFICATE OF COMPLIANCE FOR PROPOSED BUILDING WORK**

**This certificate is issued to:**

TBA

**This certificate is issued in relation to the proposed building work at:**

Non-site-specific design for the VORTEX HYDROZONE EXTREME

**Nature of proposed building work**

Construction of spa plumbing

**Building classification as per NCC 2019 Volume 2**

N/A

**Prescribed class of building work for which this certificate is issued:**

Design or part of the design of building work relating to this water recirculation matter

**Documents setting out the design that is certified by this certificate**

Document no.	Document date	Type of document	No. of pages	Prepared by
2110188 VORTEX HYDROZONE EXTREME	20/10/2021	Drawings	1	Barrason's Engineers
30P-14-0137-TRP-353298-0-Outlet Cover CMP 25201	29/08/2014	Performance Test	4	VIPAC Plumbing Products Laboratory

**The design certified by this certificate complies with the following provisions of Building Act 1993, Building Regulations 2018 or National Construction Code**

Act, Regulation or NCC	Section, Regulation, Part, Performance Requirement or other provision
NCC 2019 Volume 2	AS 1926.3 – 2010 Swimming Pool Safety Part 3: Water recirculation systems

I prepared the design, or part of the design, set out in the documents listed above.

I certify that the design set out in the documents listed above complies with the provisions set out above.

I believe that I hold the required skills, experience and knowledge to issue this certificate and can



demonstrate this if requested to do so.

**Engineer:**

**Name:** Andrew Barraclough  
**email:** admin@barrasons.com.au  
**Building Practitioner number:**

**Registrations:** FIEAUST, CPEng, NER, RBP  
**Qualifications:** BEng MEng PhD  
PE0000600  
RPEQ 22822

Signed:

Date of issue of certificate: 28/10/2021

# Hydrozone Extreme

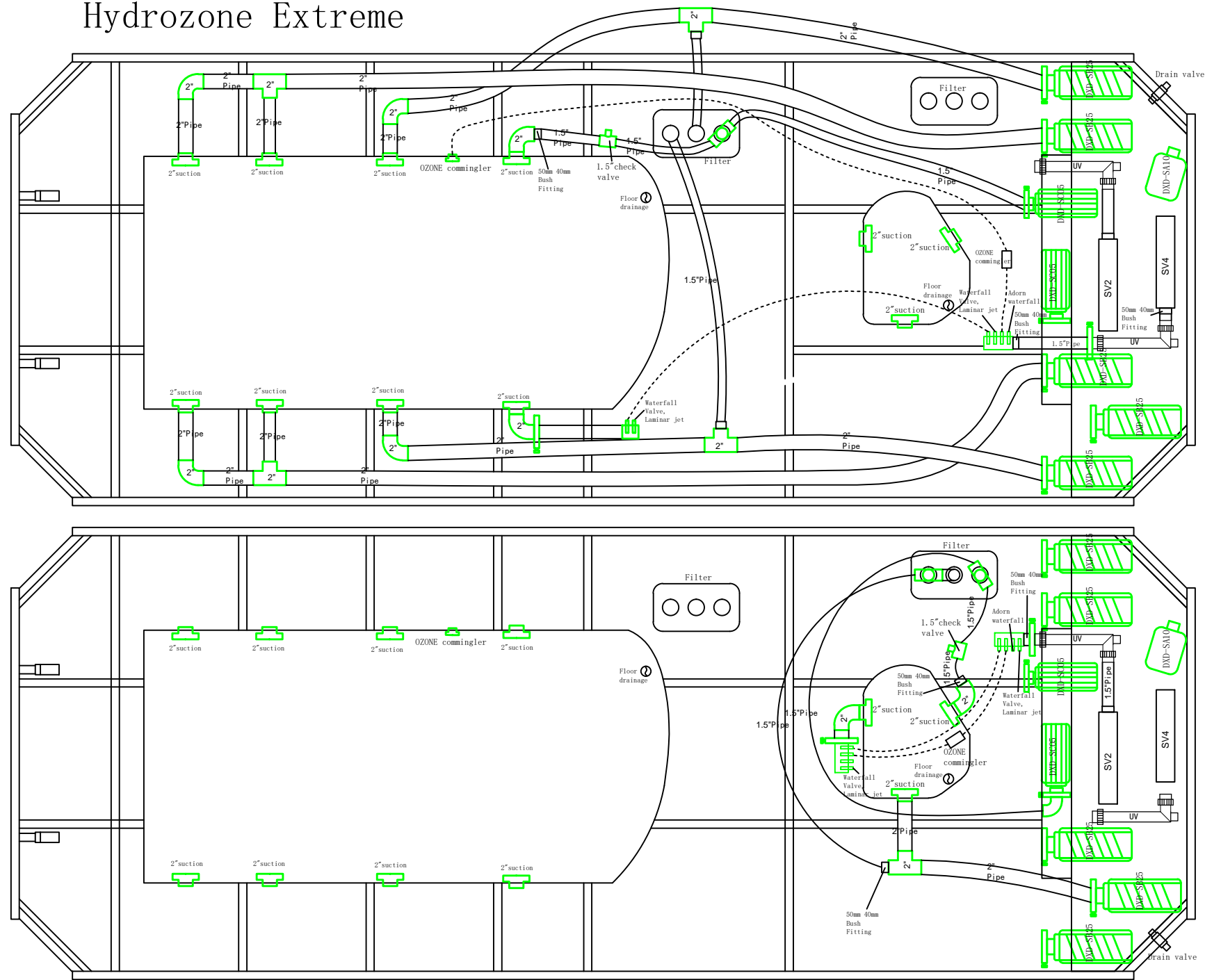

REVISION	AMENDED DESCRIPTION	DRAWN BY	DATE
A	FOR CONSTRUCTION	B.E.	26.10.2021

**Building Act 1993**  
*Section 238(1)(a)*  
**Building Regulations 2018**  
*Regulation 126*

**CERTIFICATE OF COMPLIANCE FOR PROPOSED BUILDING WORK**

**This certificate is issued to:**

TBA

**This certificate is issued in relation to the proposed building work at:**

Hydrozone Spa

**Nature of proposed building work**

Construction of spa plumbing

**Building classification as per NCC 2019 Volume 2**

N/A

**Prescribed class of building work for which this certificate is issued:**

Design or part of the design of building work relating to this water recirculation matter

**Documents setting out the design that is certified by this certificate**

Document no.	Document date	Type of document	No. of pages	Prepared by
2010282 Revision B	18/11/20	Drawings	1	Barrason's Engineers
30P-14-0137-TRP-353298-0-Outlet Cover CMP 25201	29/8/14	Performance Test	4	VIPAC Plumbing Products Laboratory

**The design certified by this certificate complies with the following provisions of Building Act 1993, Building Regulations 2018 or National Construction Code**

Act, Regulation or NCC	Section, Regulation, Part, Performance Requirement or other provision
NCC 2019 Volume 2	AS 1926.3 – 2010 Swimming Pool Safety Part 3: Water recirculation systems



I prepared the design, or part of the design, set out in the documents listed above.

I certify that the design set out in the documents listed above complies with the provisions set out above.

I believe that I hold the required skills, experience and knowledge to issue this certificate and can demonstrate this if requested to do so.

**Engineer:**

**Name:** Andrew Barraclough  
**email:** admin@barrasons.com.au  
**Building Practitioner number:**  
**Company VBA registration:**

**Registrations:** FIEAUST, CPEng, NER, RBP  
**Qualifications:** BEng MEng PhD  
EC-46301  
CEC-53929  
RPEQ 22822  
PE0000600

Signed:

Date of issue of certificate: 25/08/2021



# 3-PUMP HYDROZONE SPA PLUMBING

## NOTES:

1. SUCTION OUTLET COVERS TO BE CMP 25201 RATED TO 640 L/M
2. FILTER IS PART OF AN APPROVED ALTERNATIVE SKIMMING DEVICE

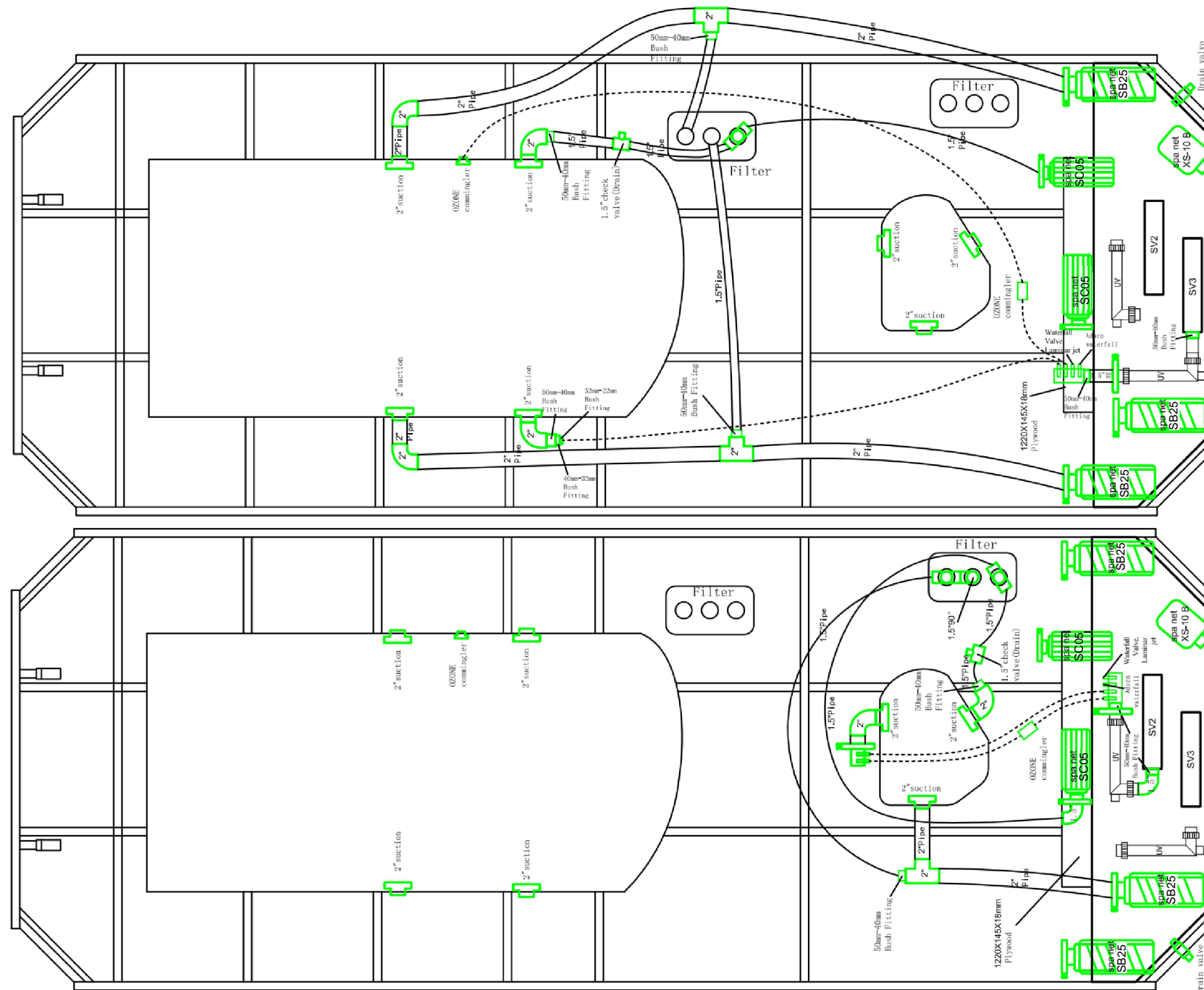

Barrason's Engineers  
 E: admin@barrasons.com.au  
 T: (03) 5940 2638  
 W: www.barrasons.com.au

HYDROZONE SPA PLUMBING

**FOR  
 CONSTRUCTION**

CLIENT: SPA WORLD

JOB No: 2010282

DRAWING No: S100

SCALE:

REVISION	AMENDED DESCRIPTION	DRAWN BY	DATE
A	FOR CONSTRUCTION	B.E.	9/11/20
B	FOR CONSTRUCTION	B.E.	18/11/20



# Vortex<sup>TM</sup> Spas

---

Available exclusively at *Spa* WORLD