

# VX LINE



VX

**cmatic**<sup>®</sup>  
P N E U M A T I C F I T T I N G S

Raccordi a Funzione in Acciaio Inox 316L  
316L Stainless Steel Function Fittings  
Raccords à fonction en Acier Inox 316L  
Funktionsverschraubungen aus Edelstahl 1.4404



.../C = Regolazione del Flusso in Uscita  
 Meter out flow control  
 Réducteur de débit fonctionnant à l'échappement  
 Abluftdrosselung

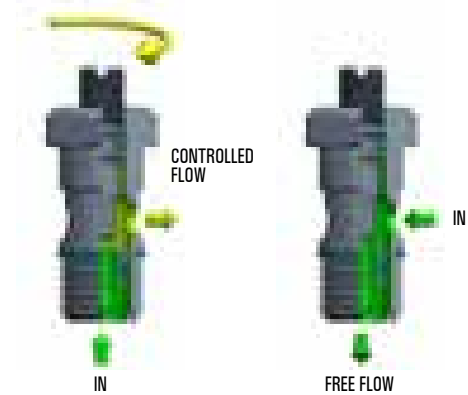

.../V = Regolazione del Flusso in Ingresso  
 Meter in flow control  
 Réducteur de débit fonctionnant à l'admission  
 Zuluftdrosselung

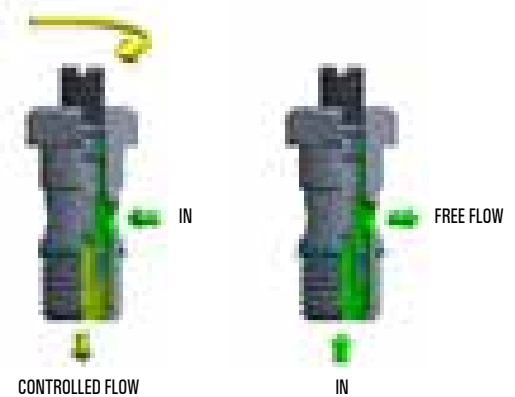

.../B = Regolazione del Flusso in entrambe le direzioni  
 Bidirectional flow control  
 Réducteur de débit bidirectionnel  
 Beidseitige Drosselung

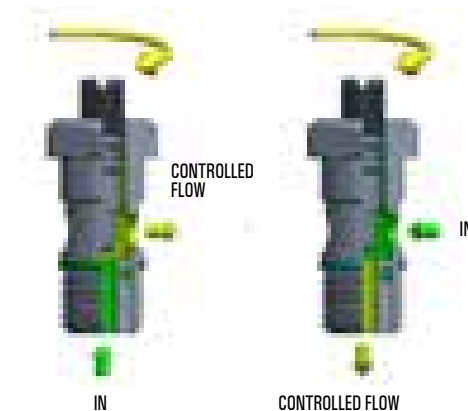

Questi dispositivi offrono la possibilità di regolare la portata d'aria in un circuito pneumatico. In base al tipo di regolatore impiegato, la regolazione può avvenire in entrambi i sensi (Regolatore Bidirezionale), oppure in un unico senso (Regolatore Unidirezionale). I Regolatori di Flusso Unidirezionali, risultano particolarmente adatti per la regolazione della velocità di cilindri pneumatici.

They can adjust the flow in a pneumatic circuit. Depending on the flow control used, the setting can be made both ways (Bidirectional Flow Control), or just one way (Unidirectional Flow Control). The Unidirectional Flow Control is particularly used to adjust the speed of pneumatic cylinders.

Leur fonction est d'assurer le réglage du débit dans un circuit pneumatique. Selon le réducteur employé, le réglage peut être effectué dans les deux sens (réducteur bidirectionnel) ou dans un seul sens (réducteur unidirectionnel). Le réducteur unidirectionnel est très utilisé pour le réglage de la vitesse de sortie de tige du vérin pneumatique.

Das Drosselrückschlagventil regelt den Durchfluss in einer pneumatischen Anlage. Je nach dem Drosselventil, kann die Drosselung auf beiden Seiten (beidseitiges Drosselrückschlagventil) oder einfach auf einer Seite erfolgen. (einseitiges Rückschlagventil). Besonders geeignet ist das einseitige Drosselrückschlagventil für die Regulierung der Zylindergerwindigkeit.

1	2	3	4	5
Corpo Body Corps Körper	Spillo Needle Epingle Nadel	Bussola Cartridge Cartouche Patrone	Guarnizioni Seals Joint d'étanchéité Dichtung	Rondella Gasket Rondelle Dichtring
Acciaio Inox AISI 316L (1.4404) Stainless Steel AISI 316L (1.4404) Acier Inox AISI 316L (1.4404) Edelstahl AISI 316L (1.4404)			FPM conforme FDA FPM Compliant With FPM conforme à FDA FPM, FDA Konform	PTFE PTFE PTFE PTFE



-20°C ÷ 150°C    0 ÷ 10 bar

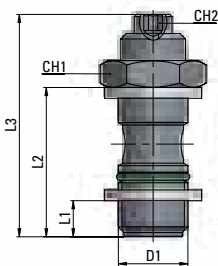
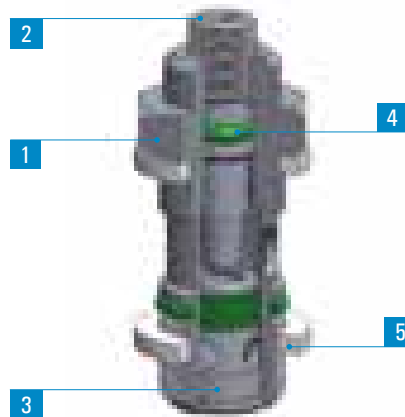

Type	D1	L1	L2	L3 max	CH1	CH2	g
15 00 18	G1/8	5,1	22,1	32,9	14	2,5	18,3
15 00 14	G1/4	6,4	27,4	41,8	17	3	34,5

Disponibile nelle versioni: Available as:

.../C



.../V



.../B



#### SPECIFICHE TECNICHE

Tubi di collegamento consigliati: variabili in funzione del tipo di raccordo collegato al regolatore.

Campi di applicazione: impianti pneumatici alimentati con aria filtrata e lubrificata.

#### DATA SHEET

Recommended tubings: according to the fitting connected to the flow control.

Application field: pneumatic installations fed with filtered, lubricated air.

#### REINSEIGNEMENTS TECHNIQUES

Tube conseillé: en fonction du raccord monté sur le réducteur.

Domaines d'application: circuits pneumatiques avec air filtré et lubrifié.

#### TECHNISCHE AUSKÜNFTE

Empfohlene Schläuche: die Schläuche werden durch die am Drosselrückschlagventil montierte verschraubung bestimmt.

Anwendungsbereiche: pneumatische Anlage mit gefilterter und geölter Druckluft.

# VX 18

Regolatore con raccordo orientabile automatico

Flow Control with swivelling push-in fitting

Réducteur de débit avec raccord automatique tournant

Drosselrückschlagventil mit schwenkbarer Steckverschraubung

1	2	3	4	5
Corpo Body Corps Körper	Spillo Needle Epingle Nadel	Bussola Cartridge Cartouche Patrone	Guarnizioni Seals Joint d'étanchéité Dichtung	Anello Banjo Ring Banjo Steckverschraubungen
Acciaio Inox AISI 316L (1.4404) Stainless Steel AISI 316L (1.4404) Acier Inox AISI 316L (1.4404) Edelstahl AISI 316L (1.4404)			FPM FPM FPM FPM	Raccordo Automatico serie MX MX line push-in fittings Raccords instantanés série MX MX Steckverschraubungen



-20°C ÷ 150°C



0 ÷ 10 bar

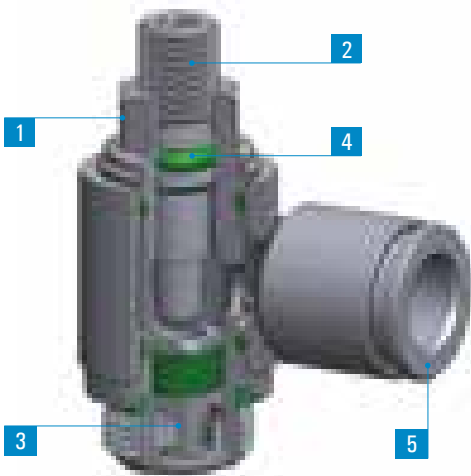

P = 6 bar - Δp = 1 bar

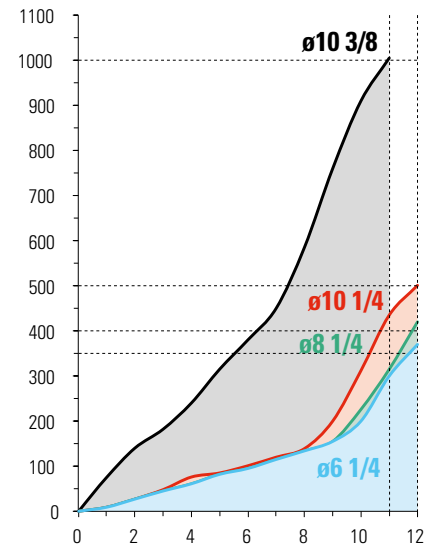
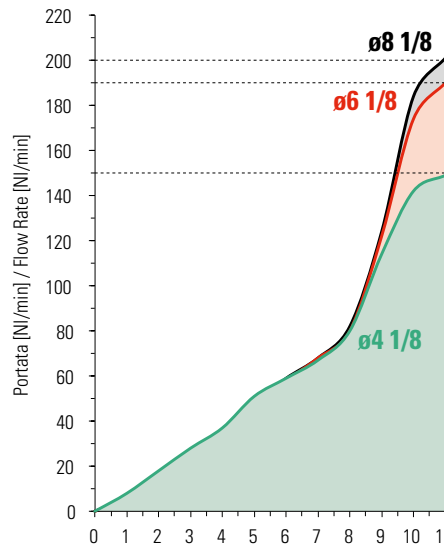

n° giri spillo di regolazione / n° of needle turns



L'anello rimane orientabile anche dopo l'installazione del regolatore.  
The banjo ring swivels also after flow control installation.  
Les banjos peuvent être orientés après l'installation du réducteur.  
Der Schwenkring kann nach der Montage des Drosselrückschlagventiles noch orientiert werden.

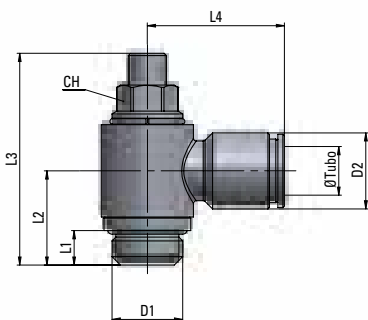

Type	Ø Tubo	D1	D2	L1	L2	L3 max	L4	CH	g Δ
18 04 18	4	G1/8	9	5,1	15	32,9	20,5	9	26
18 06 18	6	G1/8	12	5,1	15	32,9	22,5	9	28,8
18 06 14	6	G1/4	12	6,4	17,4	39	24	10	43,1
18 08 18	8	G1/8	14	5,1	15	32,9	23	9	29,5
18 08 14	8	G1/4	14	6,4	17,4	39	25	10	45,4
18 10 14	10	G1/4	16	6,4	17,4	39	27	10	47
18 10 38	10	G3/8	16	7	20	50	26	14	85,2

Disponibile nelle versioni: Available as:

.../C



.../V



.../B



## SPECIFICHE TECNICHE

Tubi di collegamento consigliati:  
Tubo in PVDF, Tubo in PTFE.

Campi di applicazione:  
impianti pneumatici alimentati con aria filtrata e lubrificata.

## DATA SHEET

Recommended tubings:  
PVDF and PTFE tubings.

Application field:  
pneumatic installations fed with filtered, lubricated air.

## REINSEIGNEMENTS TECHNIQUES

Tubes conseillés:  
Tube PVDF et Tube PTFE.

Domaines d'application:  
circuits pneumatiques avec air filtré et lubrifié.

## TECHNISCHE AUSKÜNFTE

Empfohlene Schläuche:  
PVDF, PTFE Schlauch.

Anwendungsbereiche:  
pneumatische Anlage mit gefilterter und geölter Druckluft.



1	2	3	4	5	6
Corpo Body Corps Körper	Regolatore Needle valve Réducteur de débit Drosselventil	Pomolo Handwheel Volant moleté Rändelkopf	Spillo Needle Epingle Nadel	Dado Nut Ecrou Überwurfmutter	Guarnizioni Seals Joint d'étanchéité Dichtung
Acciaio Inox AISI 316L (1.4404) Stainless Steel AISI 316L (1.4404) Acier Inox AISI 316L (1.4404) Edelstahl AISI 316L (1.4404)					FPM FPM FPM FPM



-20°C ÷ 150°C



0 ÷ 10 bar

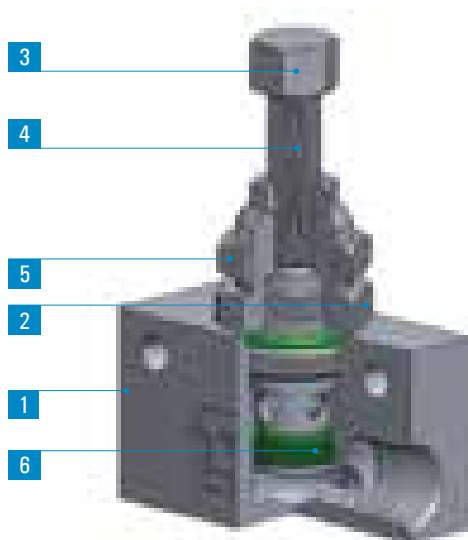

P = 6 bar - Δp = 1 bar

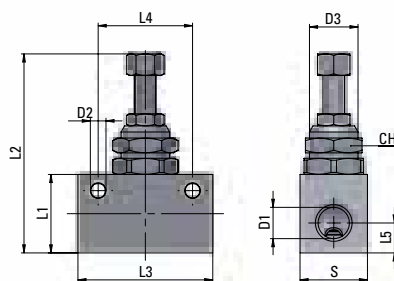
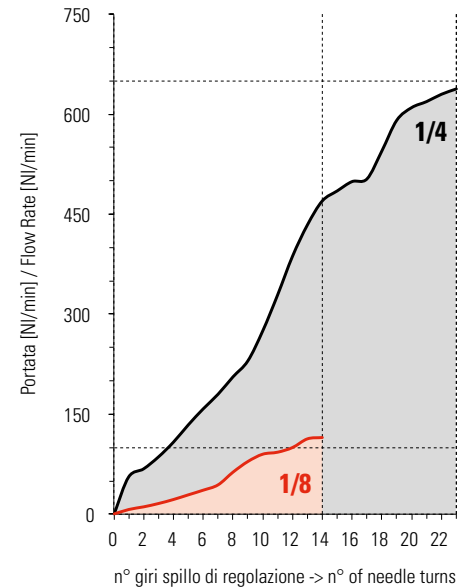

Type	D1	D2	D3	L1	L2 max	L3	L4	L5	S	CH	g $\Delta$
21 00 18	G1/8	4,5	M12x0,75	20	51,6	34	24	7,5	15	14	72,5
21 00 14	G1/4	5,4	M18x1	30	74,6	50	35	12	25	21	281,4

Disponibile nelle versioni:  
Available as:

.../U =



.../B



## SPECIFICHE TECNICHE

Tubi di collegamento consigliati:  
variabili in funzione del tipo di raccordo colle-  
gato al regolatore.

Campi di applicazione:  
impianti pneumatici alimentati con aria  
filtrata e lubrificata.

## DATA SHEET

Recommended tubings:  
according to the fitting connected to the flow  
control.

Application field:  
pneumatic installations fed with filtered,  
lubricated air.

## REINSEIGNEMENTS TECHNIQUES

Tubes conseillés:  
en fonction du raccord monté sur le réduc-  
teur.

Domaines d'application:  
circuits pneumatiques avec air filtré et  
lubrifié.

## TECHNISCHE AUSKÜNFTE

Empfohlene Schläuche:  
die Schläuche werden durch die am  
Drosselrückschlagventil montierte  
verschraubung bestimmt.

Anwendungsbereiche:  
pneumatische Anlage mit gefilterter und  
geölter Druckluft.

VX 22	Valvola di scarico rapido in inox	Stainless steel quick exhaust valve	Vanne à échappement rapide en acier inox	Schnellentlüftungsventil aus Edelstahl
1	2	3	4	
Corpo Body Corps Körper	Silenziatore Muffler Silencieux Schalldämpfer	Seeger Seeger Seeger Seeger	Guarnizioni Seals Joint d'étanchéité Dichtung	
Acciaio Inox AISI 316L (1.4404) Stainless Steel AISI 316L (1.4404) Acier Inox AISI 316L (1.4404) Edelstahl AISI 316L (1.4404)	Acciaio Inox AISI 316 Stainless Steel AISI 316 Acier Inox AISI 316 Edelstahl AISI 316	Acciaio C75 Zincato C75 Steel zinc coated Acier C75 zingué C75 Stahl verzinkt	FPM FPM FPM FPM	

  
-20°C + 150°C

  
2 + 10 bar

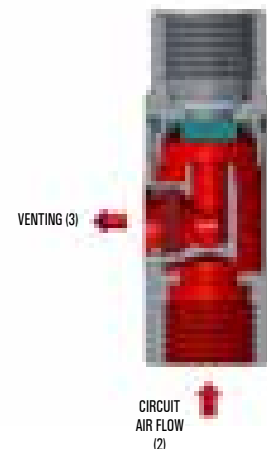
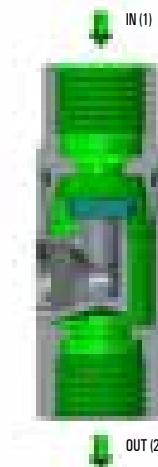
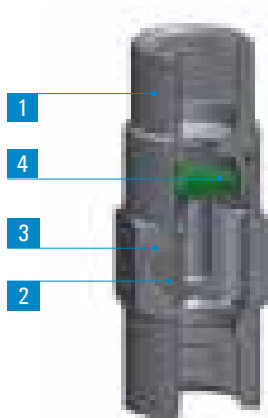

Portata a 6 bar  
Flow rate at 6 bar  
Débit à 6 bar  
Druckfluß (6 bar)

	IN OUT	OUT VENT
	1→2	2→3

1/4	1050 NI/min	660 NI/min
3/8	3000 NI/min	1900 NI/min
1/2	3420 NI/min	2280 NI/min

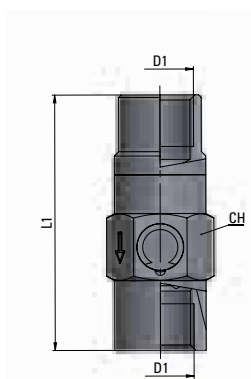

Type	D1	L1	CH	g $\Delta$
22 00 14	G1/4	49.5	18	51,5
22 00 38	G3/8	60.5	27	133,1
22 00 12	G1/2	68.5	35	257

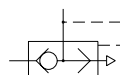

Valvola in grado di scaricare rapidamente l'aria contenuta in un circuito in caso di mancanza d'alimentazione; se applicate ad un cilindro permettono di aumentarne la velocità.

This valve can easily vent the circuit in case of an air supply failure. If assembled on the cylinder port, it increases the cylinder speed.

Cette vanne permet de mettre à l'échappement un circuit en cas de défaut d'alimentation. Raccordée sur un vérin, elle permet d'augmenter la vitesse du débit d'échappement et de ce fait d'augmenter sa vitesse de fonctionnement.

Dieses Ventil kann bei Luftmangel die Anlage schnell entlüften. Wenn am Zylinderausgang montiert, wird dessen Geschwindigkeit vergrößert.

#### SPECIFICHE TECNICHE

Tubi di collegamento consigliati: variabili in funzione del tipo di raccordo collegato alla valvola.

Campi di applicazione: impianti pneumatici alimentati con aria filtrata e lubrificata.

#### DATA SHEET

Recommended tubings: according to the fitting connected to the valve.

Application field: pneumatic installations fed with filtered, lubricated air.

#### REINSEIGNEMENTS TECHNIQUES

Tubes conseillés: en fonction du raccord monté sur la vanne.

Domaines d'application: circuits pneumatiques avec air filtré et lubrifié.

#### TECHNISCHE AUSKÜNFTE

Empfohlene Schläuche: Die Schläuche werden durch die am Schnellentlüftungsventil montierte Verschraubung bestimmt.

Anwendungsbereiche: pneumatische Anlage mit gefilterter und geölter Druckluft.

1	2	3	4
Corpo Body Corps Körper	Otturatore Valve Clapet Ventil	Guarnizioni Seals Joint d'étanchéité Dichtung	Molla Spring Ressort Feder
Acciaio Inox AISI 316L (1.4404) Stainless Steel AISI 316L (1.4404) Acier Inox AISI 316L (1.4404) Edelstahl AISI 316L (1.4404)		FPM FPM FPM FPM	Acciaio Inox AISI 302 Stainless Steel AISI 302 Acier Inox AISI 302 Edelstahl AISI 302

-20°C ÷ 150°C    
 2 ÷ 10 bar    
 0,2 bar    
    
    
    
    

P = 6 bar - Δp = 1 bar

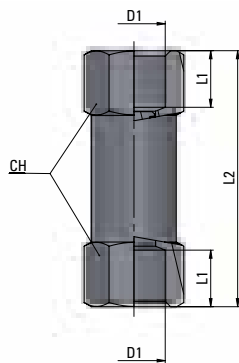
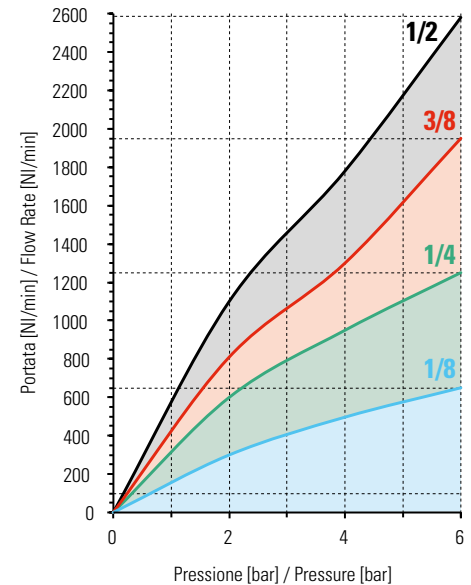
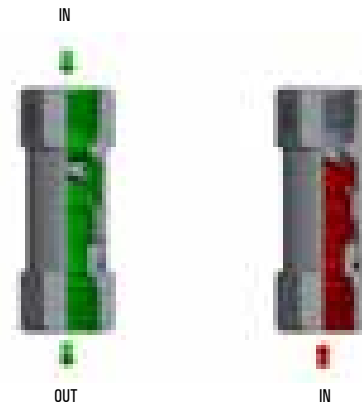

Type	D1	L1	L2	CH	g $\Delta$
23 00 18	G1/8	8	39.7	13	26
23 00 14	G1/4	8.5	47.5	16	38,1
23 00 38	G3/8	10,5	51	21	76,1
23 00 12	G1/2	12,5	62	24	111,4

Queste valvole permettono il passaggio dell'aria in un unico senso (indicato sul corpo della valvola da una freccia) impedendolo in senso contrario.

The flow is allowed only in one way (the arrow direction engraved on the body) and stopped in the reverse way.

Il permet le passage du débit dans un seul sens (celui marqué sur le corps de la vanne par une flèche) tout en empechant son retour dans le sens contraire.

Der Durchfluss wird nur einseitig erlaubt. Im Allgemeinen ist es die Richtung entsprechend dem auf dem Rückschlagventilskörper gekennzeichneten Pfeil. Die andere Seite bleibt abgesperrt.

**SPECIFICHE TECNICHE**

Tubi di collegamento consigliati: variabili in funzione del tipo di raccordo collegato alla valvola.

**DATA SHEET**

Recommended tubings: according to the fitting connected to the valve.

**REINSEIGNEMENTS TECHNIQUES**

Tubes conseillés: en fonction du raccord monté sur la vanne.

**TECHNISCHE AUSKÜNFTE**

Empfohlene Schläuche: Die Schläuche werden durch die am Schnelllüftungsventil montierte Verschraubung bestimmt.

Campi di applicazione: impianti pneumatici alimentati con aria filtrata e lubrificata.

Application field: pneumatic installations fed with filtered, lubricated air.

Domaines d'application: circuits pneumatiques avec air filtré et lubrifié

Anwendungsbereiche: pneumatische Anlage mit gefilterter und geölter Druckluft.

# VX 11

Silenziatori

Air mufflers

Silencieux

Schalldämpfer

Corpo  
Body  
Corps  
Körper

Silenziatore  
Muffler  
Silencieux  
Schalldämpfer



VX11-FE

Acciaio Inox AISI 304  
Stainless Steel AISI 304  
Acier Inox AISI 304  
Edelstahl AISI 304

Acciaio Inox AISI 304  
Stainless Steel AISI 304  
Acier Inox AISI 304  
Edelstahl AISI 304

-20°C + 150°C

0 + 12 bar

## VX 11-FE

Silenziatore con filo in acciaio inox

Air muffler with stainless steel wire

Silencieux avec fil acier inox

Schalldämpfer mit Edelstahldraht

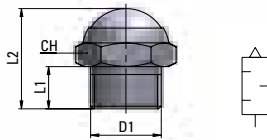

Type	D1	L1	L2	CH	g $\Delta$
11 00 18-FE	G1/8	6	15	13	5,8
11 00 14-FE	G1/4	8	18	16	9,7
11 00 38-FE	G3/8	8	19	19	14,1
11 00 12-FE	G1/2	9	22	24	21,8

Valvola manuale 2 vie

2 way manual valve

Vanne 2 voies, manuelle

2 Wege Handventil

	1	2	3	4
<b>VX24 - VX25</b>	Corpo Body Corps Körper	Leva Handle Manette Griff	Rondella Gasket Rondelle Dichtring	Guarnizioni Seals Joint d'étanchéité Dichtung
	Acciaio Inox AISI 316L (1.4404) Stainless Steel AISI 316L (1.4404) Acier Inox AISI 316L (1.4404) Edelstahl AISI 316L (1.4404)		PTFE PTFE PTFE PTFE	FPM FPM FPM FPM

VX

1/8	6 mm
1/4	6 mm
3/8	8 mm
1/2	10 mm

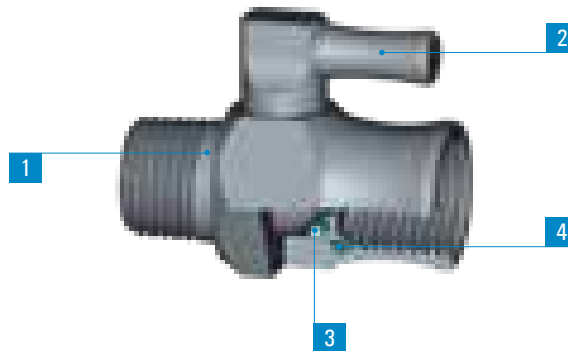

**VX 24**

Valvola manuale 2 vie, F-F

2 way manual valve, female

Vanne 2 voies, manuelle, femelle

2 Wege Handventil mit Innengewinde

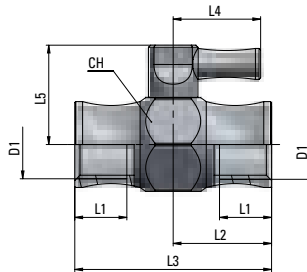

Type	D1	L1	L2	L3	L4	L5	CH	g $\Delta$
24 00 18	G1/8	8	19	37.8	17	19	18	54
24 00 14	G1/4	9	19	37.8	17	19	18	43,4
24 00 38	G3/8	10	24,5	39	24,5	26	22	67
24 00 12	G1/2	11	28,5	45.5	24,5	28	26	132,5

**VX 25**

Valvola manuale 2 vie, M-F

2 way manual valve, male-female

Vanne 2 voies, manuelle, mâle-femelle

2 Wege Handventil Einschraub-Aufschraub

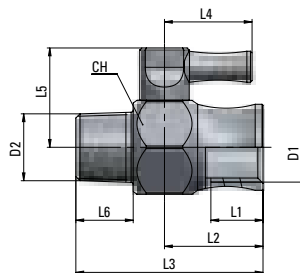

Type	D1	D2	L1	L2	L3	L4	L5	L6	CH	g $\Delta$
25 00 18	G1/8	R1/8	8	19	32.8	17	19	7,5	18	46,4
25 00 14	G1/4	R1/4	9	19	35.9	17	19	11	18	41,5
25 00 38	G3/8	R3/8	10	24,5	37.3	24,5	26	11,5	22	85,7
25 00 12	G1/2	R1/2	11	28,5	43.1	24,5	28	14	26	90,1