

cmatic[®]
PNEUMATIC FITTINGS

食品和饮料应用领域标准接头
Standard Fittings for Food and Beverage Applications



RF系列标准接头专为满足食品与饮料行业的应用，该系列材质为低铅黄铜，符合169 NSF/ANSI要求，可以与水，茶和咖啡接触，是咖啡机和饮料贩卖机的理想选择。
在169 NSF/ANSI认证的基础上，RF系列还以其微小的含铅量，达到了NSF/ANSI372的要求，可以直接与饮用水接触。（美国安全饮用水法）



RF is a Standard Fitting line certified for Food and Beverage applications. RF Fitting is made of brass with low lead content and it is NSF certified according to the 169 standards for contact with water, tea and coffee. This makes RF Fitting the right solution for the coffee and vending machines industry. On top of the 169 NSF/ANSI Certificate, the RF Fitting boasts also the NSF/ANSI 372 brass compliance with the maximum lead content standards allowed for contact with drinking water (U.S. Safe Drinking Water Act).

本体
Body

黄铜 EN 12164 CW510L 符合 NSF/ANSI 372
Brass EN12164 CW510L Compliant NSF/ANSI 372



-40°C - 150°C



最大60 bar



Certified to NSF/ANSI 169

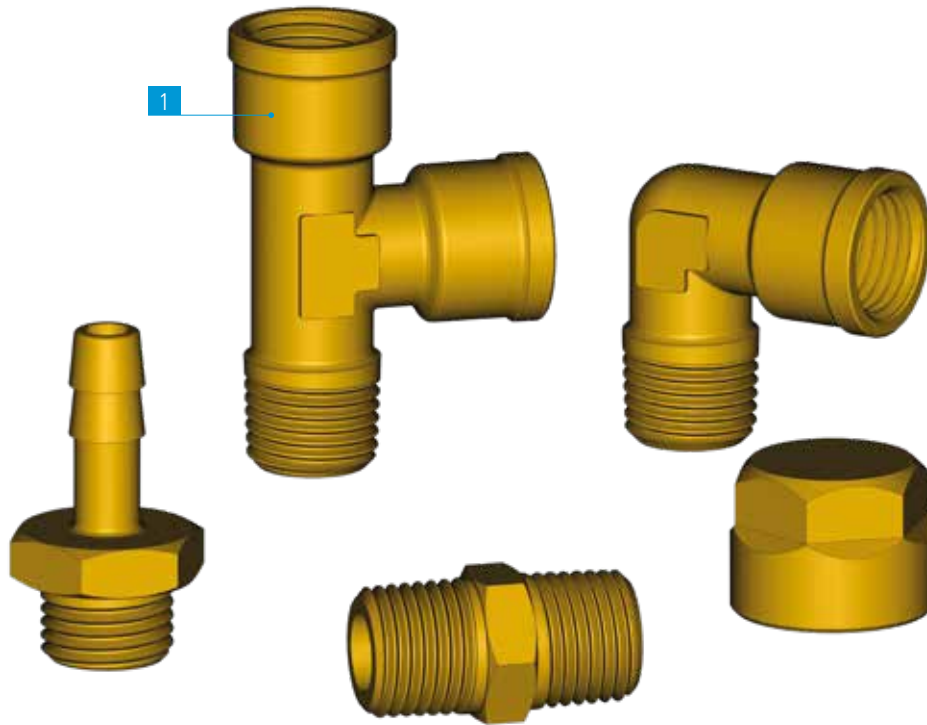

| | G1/8 | G1/4 | G3/8 | R1/8 | R1/4 | R3/8 |
|--|------|------|------|------|------|------|
| | • | • | • | • | • | • |
| | | | | | | |

技术规格

应用领域：
食品和饮料领域应用

DATA SHEET

Application fields:
Food and Beverage Applications.

RF 12

锥螺纹转接头

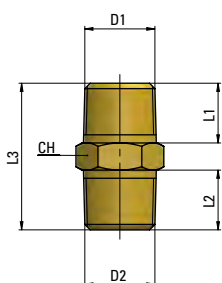

Nipple, taper

| 类型 | D1 | D2 | L1 | L2 | L3 | CH | g $\Delta\Delta$ |
|----------|------|------|------|------|------|----|------------------|
| 12 18 18 | R1/8 | R1/8 | 7.5 | 7.5 | 20 | 12 | 8 |
| 12 18 14 | R1/8 | R1/4 | 7.5 | 11 | 23.5 | 14 | 12 |
| 12 14 14 | R1/4 | R1/4 | 11 | 11 | 27 | 14 | 17.5 |
| 12 14 38 | R1/4 | R3/8 | 11 | 11.5 | 27.5 | 17 | 20 |
| 12 38 38 | R3/8 | R3/8 | 11.5 | 11.5 | 28 | 17 | 23 |

RF 13

转接头

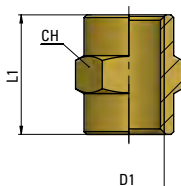

Joint Piece

| 类型 | D1 | L1 | CH | g $\Delta\Delta$ |
|----------|------|----|----|------------------|
| 13 00 18 | G1/8 | 15 | 14 | 10.6 |
| 13 00 14 | G1/4 | 22 | 17 | 18.7 |
| 13 00 38 | G3/8 | 23 | 20 | 34.5 |

RF 14

锥螺纹减径接头

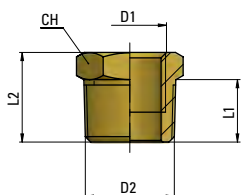

Taper Female-Male reducing connector

| 类型 | D1 | D2 | L1 | L2 | CH | g $\Delta\Delta$ |
|----------|------|------|------|------|----|------------------|
| 14 18 14 | G1/8 | R1/4 | 11 | 16 | 14 | 10.6 |
| 14 18 38 | G1/8 | R3/8 | 11.5 | 16.5 | 17 | 20.7 |
| 14 14 38 | G1/4 | R3/8 | 11.5 | 16.5 | 17 | 12.6 |

RF 16

锥螺纹内外转接头

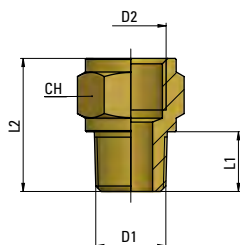

Adaptor Male-Female, taper

| 类型 | D1 | D2 | L1 | L2 | CH | g $\Delta\Delta$ |
|----------|------|------|------|------|----|------------------|
| 16 18 18 | R1/8 | G1/8 | 8 | 18 | 14 | 13 |
| 16 18 14 | R1/8 | G1/4 | 8 | 21.5 | 17 | 18 |
| 16 14 14 | R1/4 | G1/4 | 11 | 24.5 | 17 | 22 |
| 16 14 38 | R1/4 | G3/8 | 11 | 25.5 | 20 | 42 |
| 16 38 38 | R3/8 | G3/8 | 11.5 | 26 | 20 | 42 |

RF 19

直螺纹堵头

Parallel Plug

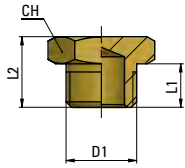

| 类型 | D1 | L1 | L2 | CH | g Δ |
|----------|------|----|------|----|------------|
| 19 00 18 | G1/8 | 6 | 10 | 14 | 7.5 |
| 19 00 14 | G1/4 | 8 | 13 | 17 | 13.5 |
| 19 00 38 | G3/8 | 9 | 13.5 | 20 | 18 |

RF 20

内螺纹堵头

Female Plug

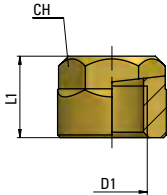

| 类型 | D1 | L1 | CH | g Δ |
|----------|------|------|----|------------|
| 20 00 18 | G1/8 | 10 | 14 | 9.6 |
| 20 00 14 | G1/4 | 13.5 | 17 | 16.7 |
| 20 00 38 | G3/8 | 14 | 20 | 21.3 |

RF 21

内螺纹直角转接头

Female Elbow

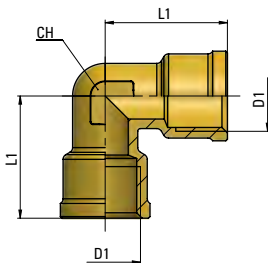

| 类型 | D1 | L1 | CH | g Δ |
|----------|------|------|----|------------|
| 21 18 18 | G1/8 | 18.5 | 10 | 15 |
| 21 14 14 | G1/4 | 22.5 | 12 | 26 |
| 21 38 38 | G3/8 | 25.5 | 15 | 44 |

RF 22

内外螺纹直角转接头

Male-Female Elbow

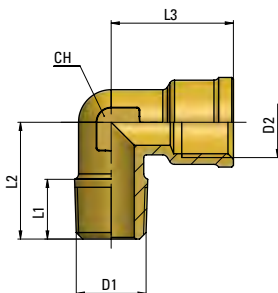

| 类型 | D1 | D2 | L1 | L2 | L3 | CH | g Δ |
|----------|------|------|------|------|------|----|------------|
| 22 18 18 | R1/8 | G1/8 | 8 | 17 | 18.5 | 10 | 12.5 |
| 22 14 14 | R1/4 | G1/4 | 11 | 21.5 | 22.5 | 12 | 23.5 |
| 22 38 38 | R3/8 | G3/8 | 11.5 | 24.5 | 25.5 | 15 | 41 |

RF 23

内螺纹三通转接头

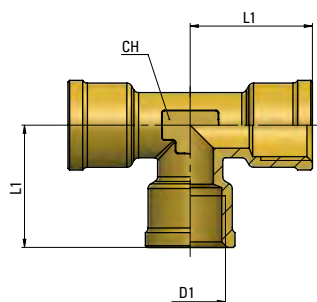

Female Tee

| 类型 | D1 | L1 | CH | g Δ |
|----------|------|------|----|------------|
| 23 18 18 | G1/8 | 18.5 | 10 | 21 |
| 23 14 14 | G1/4 | 22.5 | 12 | 36 |
| 23 38 38 | G3/8 | 25.5 | 15 | 61 |

RF 24

内外螺纹三通转接头

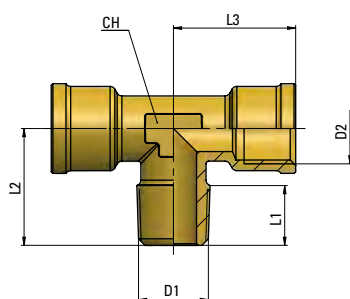

Female-Male-Female Tee

| 类型 | D1 | D2 | L1 | L2 | L3 | CH | g Δ |
|----------|------|------|------|------|------|----|------------|
| 24 18 18 | R1/8 | G1/8 | 8 | 17 | 18.5 | 10 | 19 |
| 24 14 14 | R1/4 | G1/4 | 11 | 21.5 | 22.5 | 12 | 34 |
| 24 38 38 | R3/8 | G3/8 | 11.5 | 24.5 | 25.5 | 15 | 58 |

RF 25

直T型内外螺纹三通转接头

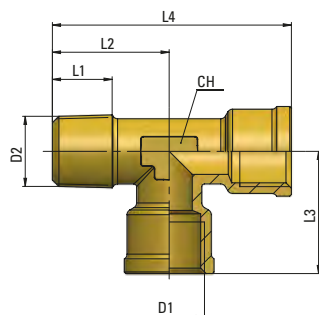

Male-Female- Female Tee

| 类型 | D1 | D2 | L1 | L2 | L3 | L4 | CH | g Δ |
|----------|------|------|------|------|------|------|----|------------|
| 25 18 18 | G1/8 | R1/8 | 8 | 17 | 18.5 | 35.5 | 10 | 19 |
| 25 14 14 | G1/4 | R1/4 | 11 | 21.5 | 22.5 | 44 | 12 | 34 |
| 25 38 38 | G3/8 | R3/8 | 11.5 | 24.5 | 25.5 | 50 | 15 | 57 |

RF 30

软管接头

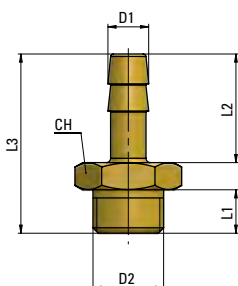

Hose Connector

| 类型 | 管径 \varnothing | D1 | D2 | L1 | L2 | L3 | CH | g Δ |
|-----------|------------------|-----|------|----|----|----|----|------------|
| 30 6.5 18 | 6 | 6.5 | G1/8 | 6 | 20 | 30 | 14 | 10.5 |
| 30 6.5 14 | 6 | 6.5 | G1/4 | 8 | 20 | 33 | 17 | 17 |

RF 35

外螺纹弯管接头

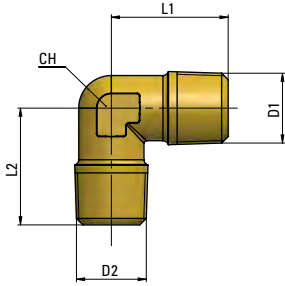

Male-Male Elbow

| 类型 | D1 | D2 | L1 | L2 | CH | g Δ |
|----------|------|------|------|------|----|------------|
| 35 18 18 | R1/8 | R1/8 | 17 | 17 | 10 | 10.5 |
| 35 18 14 | R1/8 | R1/4 | 17 | 21.5 | 12 | 17 |
| 35 14 14 | R1/4 | R1/4 | 21.5 | 21.5 | 12 | 21 |
| 35 14 38 | R1/4 | R3/8 | 21.5 | 24.5 | 15 | 29 |
| 35 38 38 | R3/8 | R3/8 | 24.5 | 24.5 | 15 | 37 |

RF 36

外螺纹三通转接头

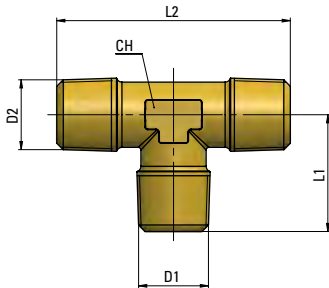

Male Tee

| 类型 | D1 | D2 | L1 | L2 | CH | g Δ |
|----------|------|------|------|----|----|------------|
| 36 18 18 | R1/8 | R1/8 | 17 | 34 | 10 | 14 |
| 36 14 14 | R1/4 | R1/4 | 21.5 | 43 | 12 | 29 |
| 36 38 38 | R3/8 | R3/8 | 24.5 | 49 | 15 | 51 |

RF 45

内外螺纹三通转接头

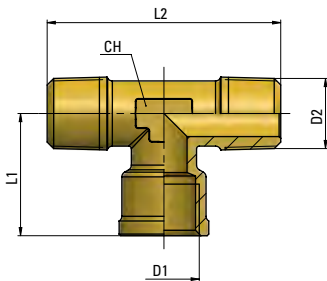

Male-Female-Male Tee

| 类型 | D1 | D2 | L1 | L2 | CH | g Δ |
|----------|------|------|------|----|----|------------|
| 45 18 18 | G1/8 | R1/8 | 18.5 | 34 | 10 | 16.5 |
| 45 14 14 | G1/4 | R1/4 | 22.5 | 43 | 12 | 31 |
| 45 38 38 | G3/8 | R3/8 | 25.5 | 49 | 15 | 54 |

RF 47

内外螺纹三通转接头

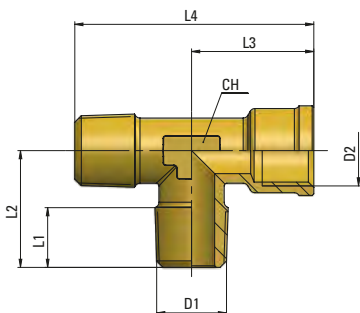

Male-Male-Female Tee

| 类型 | D1 | D2 | L1 | L2 | L3 | L4 | CH | g Δ |
|----------|------|------|------|------|------|------|----|------------|
| 47 18 18 | R1/8 | G1/8 | 8 | 17 | 18.5 | 35.5 | 10 | 16.5 |
| 47 14 14 | R1/4 | G1/4 | 11 | 21.5 | 22.5 | 44 | 12 | 31 |
| 47 38 38 | R1/4 | G3/8 | 11.5 | 24.5 | 25.5 | 50 | 15 | 54 |