

MC LINE



CN

黄铜镀镍快拧接头

MC系列快拧接头采用锥面涉及，当管路安装完毕并拧紧螺母时，可确保密封。所有MC系列接头均表面电解镀镍。

EN

Brass Nickel-Plated Push-on Fittings

The Push-on Fittings of the MC line are provided with a cone to ensure the perfect tightness once the tubing is assembled and the nut tightened. All MC fittings are electrolytic nickel plated.

MC Line

1 本体
Body

黄铜镀镍 UNI EN 12164 CW614N - UNI EN 12165 CW617N
Brass UNI EN 12164 CW614N - UNI EN 12165 CW617N, nickel plated

2 螺母
Nut

黄铜镀镍 UNI EN 12164 CW614N
Brass UNI EN 12164 CW614N, nickel plated



-40° ÷ 150°C



25 bar



-99 KPa

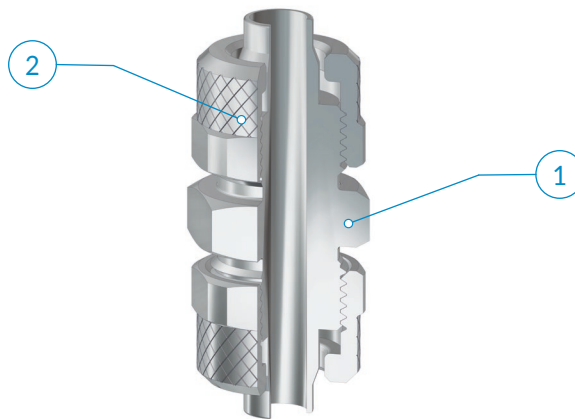

	M5x0,8	G1/8	G1/4	G3/8	G1/2	R1/8	R1/4	R3/8	R1/2
4	●	●				●			
5	●	●				●			
6	●	●	●	●		●	●	●	
8		●	●	●		●	●	●	
10		●	●	●	●	●	●	●	●
12				●	●			●	●
15					●				●

建议的连接管路:
PA11、PA12、PE聚乙烯、PU聚氨酯。

Recommended tubings:
PA11, PA12, Polyethylene PE, Polyurethane PU

可接受的管路公差:
+/- 0.07 mm, 最大直径 10 mm
+/- 0.1 mm, 最大直径 Ø 15 mm。

Acceptable Tolerances on the tubings:
+/- 0,07 mm up to Ø 10 mm
+/- 0,1 mm up to Ø 15 mm

应用领域:
气动系统。

Application fields:
Pneumatic circuits

- 1**
垂直切割管路, 确认管路内外壁没有毛刺
- 2**
将螺母套入管路
- 3**
将管路套在锥面上, 用力推入至压紧程度
- 4**
用手或者扳手拧紧螺母

- 1**
Cut the tube at 90° making sure that no burr is left;
- 2**
Push the nut onto the tube;
- 3**
Push the tube and nut onto the fitting nozzle and make sure that the tube goes all the way up to the nozzle base;
- 4**
Tighten the nut by hand or if necessary by a spanner.

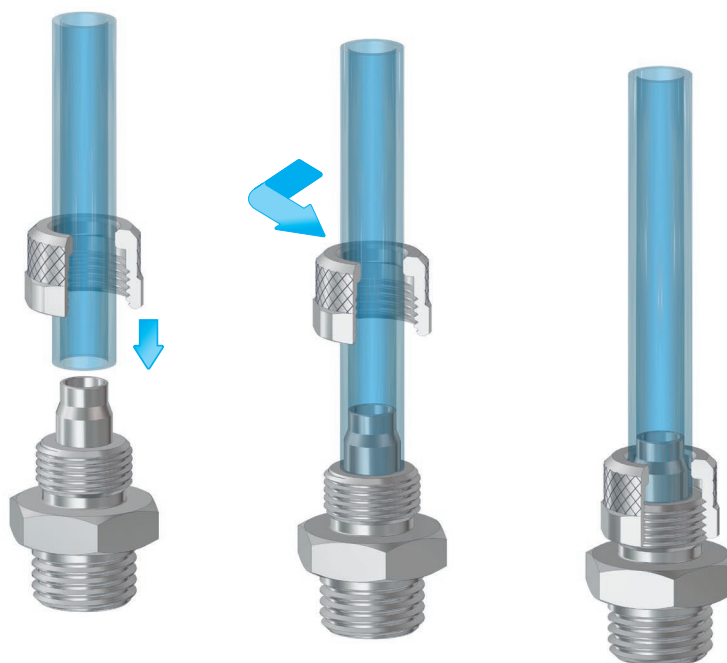

! 完成连接后, 请确保管路上不承受外力; 此外, 请确保管路连接的最小弯曲半径符合本样册第376页之规定。为了避免管路意外松脱, 任何物体均不要接触释放环。作用在释放环上任何外力, 包括侧向力, 均可能导致管路意外松脱。螺纹拧紧时, 请参考第10页列出的建议扭矩。

! Once the tubing is connected to the fitting, make sure that the tubing is not subject to any tensile strength and that the min. recommended bending radius stated in the tubing section of this catalogue is complied with (see page 376). To tighten threads, please check out our tightening torque chart illustrated at page 10.

MC 11

外锥螺纹直接头

Taper straight, male

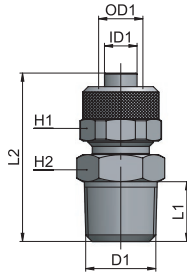

类型	OD1	ID1	D1	L1	L2	H1	H2	g Δ
11 04 18	4	2,5	R1/8	7,5	23,5	7	11	7,4
11 05 18	5	3	R1/8	8	25	8	12	8,6
11 06 18	6	4	R1/8	8	27,5	12	12	15,0
11 06 14	6	4	R1/4	11	31	12	14	20,6
11 06 38	6	4	R3/8	11,5	31,5	12	17	23,9
11 08 18	8	6	R1/8	8	27,5	14	12	17,7
11 08 14	8	6	R1/4	11	31	14	14	22,5
11 08 38	8	6	R3/8	11,5	31,5	14	17	27,4
11 10 18	10	8	R1/8	8	29,5	16	14	22,0
11 10 14	10	8	R1/4	11	32,5	16	14	26,6
11 10 38	10	8	R3/8	11,5	33	16	17	33,1
11 10 12	10	8	R1/2	14	36	16	22	48,3
11 12 38	12	10	R3/8	11,5	34,5	18	17	37,3
11 12 12	12	10	R1/2	14	37,5	18	22	49,5
11 15 12	15	12,5	R1/2	14	39,5	22	22	61,9

MC 12

外直螺纹直接头

Parallel straight, male

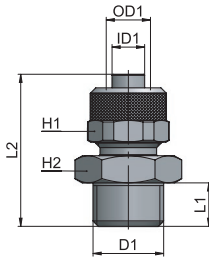

类型	OD1	ID1	D1	L1	L2	H1	H2	g Δ
12 04 M5	4	2,5	M5x0,8	5	20	7	7	3,4
12 04 18	4	2,5	G1/8	6	22,5	7	14	9,7
12 05 M5	5	3	M5x0,8	4	20	8	8	4,8
12 05 18	5	3	G1/8	6	23	8	14	10,6
12 06 M5	6	4	M5x0,8	4	21	9	8	6,1
12 06 18	6	4	G1/8	6	25,5	12	14	16,4
12 06 14	6	4	G1/4	8	28	12	17	21,0
12 06 38	6	4	G3/8	9	29	12	19	27,5
12 08 18	8	6	G1/8	6	25,5	14	14	19,5
12 08 14	8	6	G1/4	8	28	14	17	25,2
12 08 38	8	6	G3/8	9	29	14	19	30,1
12 10 18	10	8	G1/8	6	27,5	16	14	22,9
12 10 14	10	8	G1/4	8	29,5	16	17	29,4
12 10 38	10	8	G3/8	9	30,5	16	19	32,6
12 10 12	10	8	G1/2	10	32	16	24	45,1
12 12 38	12	10	G3/8	9	32	18	19	38,1
12 12 12	12	10	G1/2	10	33,5	18	24	53,2
12 15 12	15	12,5	G1/2	10	33,5	22	24	60,9

O型圈选装 - O-ring on request

MC 13

内螺纹直接头

Female straight

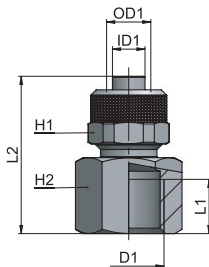

类型	OD1	ID1	D1	L1	L2	H1	H2	g Δ
13 05 18	5	3	G1/8	8	22,5	8	14	12,4
13 06 18	6	4	G1/8	8	25	12	14	17,8
13 06 14	6	4	G1/4	11	29	12	17	24,8
13 08 18	8	6	G1/8	8	25	14	14	20,1
13 08 14	8	6	G1/4	11	29	14	17	27,5
13 08 38	8	6	G3/8	11,5	29,5	14	20	31,1
13 10 14	10	8	G1/4	11	30,5	16	17	32,2
13 10 38	10	8	G3/8	11,5	31	16	20	36,1
13 12 38	12	10	G3/8	11,5	32,5	18	20	38,1

MC 14

对接接头

Union

类型	OD1	ID1	L1	H1	H2	g Δ
14 05 05	5	3	28,5	8	8	7,5
14 06 06	6	4	34,5	12	12	20,5
14 08 08	8	6	35	14	14	27,9
14 10 10	10	8	38	16	14	36,0
14 12 12	12	10	41	18	17	47,0
14 15 15	15	12,5	45,5	22	22	74,6

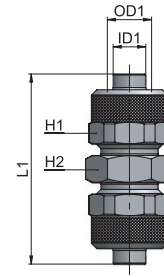

MC 15

穿板对接接头

Bulkhead union

类型	OD1	ID1	D1	L1	L2	H1	H2	g Δ
15 05 05	5	3	M7x0,75	40	8,5	8	9	10,9
15 06 06	6	4	M10x1	48	10,5	12	14	33,2
15 08 08	8	6	M12x1	48	10,5	14	16	42,6
15 10 10	10	8	M14x1	50	8,5	16	17	56,0
15 12 12	12	10	M16x1	53	8,5	18	19	66,8
15 15 15	15	12,5	M20x1	58	8,5	22	24	104,6

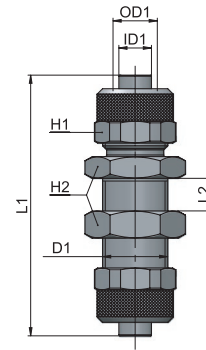

MC 16

外锥螺纹弯管接头

Taper elbow fitting, male

类型	OD1	ID1	D1	L1	L2	L3	H1	H2	g Δ
16 04 M5	4	2,5	M5x0,8	5	15,5	20	7	9	10,4
16 04 18	4	2,5	R1/8	7,5	17	20	7	9	10,7
16 05 18	5	3	R1/8	8	17	21,5	8	8	10,8
16 06 18	6	4	R1/8	8	17	22,5	12	8	16,0
16 06 14	6	4	R1/4	11	20	22,5	12	10	21,6
16 06 38	6	4	R3/8	11,5	22,5	23,5	12	11	30,3
16 08 18	8	6	R1/8	8	17	22,5	14	10	19,4
16 08 14	8	6	R1/4	11	20	22,5	14	10	23,3
16 08 38	8	6	R3/8	11,5	22,5	24	14	11	31,0
16 10 18	10	8	R1/8	8	18,5	25,5	16	11	27,6
16 10 14	10	8	R1/4	11	21,5	25,5	16	11	30,5
16 10 38	10	8	R3/8	11,5	22,5	25,5	16	11	34,7
16 12 38	12	10	R3/8	11,5	24,5	30	18	14	46,0
16 12 12	12	10	R1/2	14	28	30,5	18	17	66,5
16 15 12	15	12,5	R1/2	14	28	34	22	17	69,6

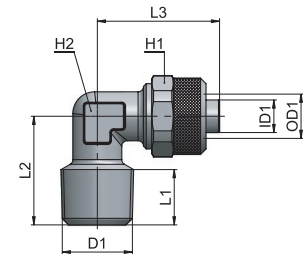

根据需要, 可提供可调向带O型圈型式 - Swivelling with O-ring on request

MC 17

内螺纹弯管接头

Female elbow

类型	OD1	ID1	D1	L1	L2	L3	H1	H2	g Δ
17 05 18	5	3	G1/8	8	19	21,5	8	10	20,8
17 06 18	6	4	G1/8	8	19	22,7	12	10	20,5
17 06 14	6	4	G1/4	11	23	24,5	12	11	30,6
17 08 18	8	6	G1/8	8	19	22,7	14	10	23,0
17 08 14	8	6	G1/4	11	23	25	14	11	31,0
17 10 14	10	8	G1/4	11	23,5	26	16	13	39,2
17 12 38	12	10	G3/8	11,5	28	30,5	18	17	61,3

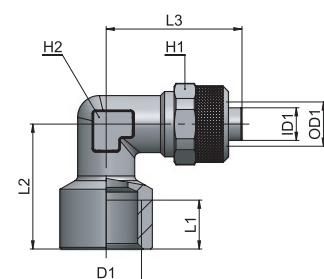

AP 55
AR 63
AV 221
CO 157
CX 255
EV 217
GU 119
GU Safety 135
GX 281
GX Safety 291
HP 317
MA 27
MB 41
MC 83
MF 235
MM 333
MO 93
MP 323
MT 339
MV 171
MX 241
MY 229
OX 261
PA 113
PE 79
PM 329
PN 67
PT 347
PU 131
PU Safety 149
PUX 287
PV 203
PVX 311
PX 249
QO 363
RA 101
RF 269
RT 355
RX 275
Tools 369
Tubings 375
VF 295
VT 359
VX 299

MC 18

直角对接接头

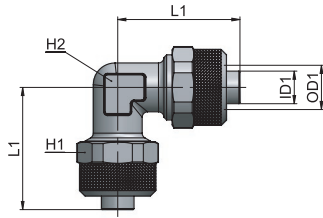

Union elbow

类型	OD1	ID1	L1	H1	H2	g
18 05 05	5	3	21,5	8	8	13,1
18 06 06	6	4	21,5	12	8	22,7
18 08 08	8	6	22,5	14	10	28,4
18 10 10	10	8	25,5	16	11	38,6
18 12 12	12	10	30	18	14	58,0
18 15 15	15	12,5	34	22	17	84,3

MC 19

正T型三通对接接头

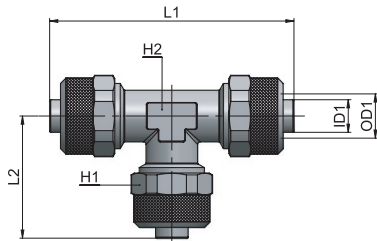

Union T

类型	OD1	ID1	L1	L2	H1	H2	g
19 05 05	5	3	43	21,5	8	8	18,6
19 06 06	6	4	45	22,5	12	8	32,1
19 08 08	8	6	45	22,5	14	10	41,3
19 10 10	10	8	51	25,5	16	11	54,5
19 12 12	12	10	60	30	18	14	84,9
19 15 15	15	12,5	68	34	22	17	124,2

MC 20

锥螺纹正T型三通接头

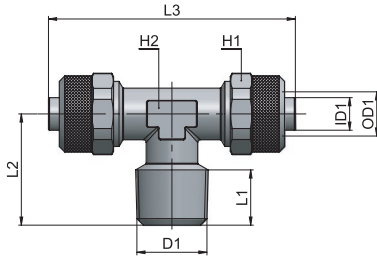

Taper male T

类型	OD1	ID1	D1	L1	L2	L3	H1	H2	g
20 05 18	5	3	R1/8	8	17	43	8	8	17,5
20 06 18	6	4	R1/8	8	17	45	12	8	27,0
20 06 14	6	4	R1/4	11	20,5	45,5	12	10	35,2
20 08 18	8	6	R1/8	8	17,5	45,5	14	10	33,6
20 08 14	8	6	R1/4	11	20,5	45,5	14	10	37,7
20 10 14	10	8	R1/4	11	21,5	51	16	11	48,0
20 10 38	10	8	R3/8	11,5	22,5	51	16	11	50,0
20 12 38	12	10	R3/8	11,5	24,5	60	18	14	69,5
20 12 12	12	10	R1/2	14	28	61	18	17	85,0
20 15 12	15	12,5	R1/2	14	28	68	22	17	108,3

根据需要，可提供可调带O型圈型式 - Swivelling with O-ring on request

MC 21

锥螺纹直T型三通接头

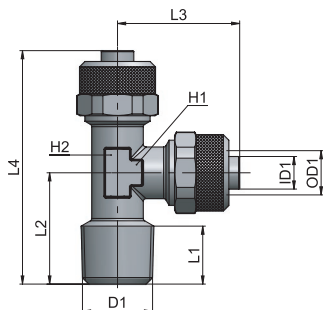

Taper lateral T

类型	OD1	ID1	D1	L1	L2	L3	L4	H1	H2	g
21 05 18	5	3	R1/8	8	17	21,5	38,5	8	8	17,7
21 06 18	6	4	R1/8	8	17	22,5	39,5	12	8	25,8
21 06 14	6	4	R1/4	11	20,7	22,7	43,5	12	10	33,8
21 08 18	8	6	R1/8	8	17,7	22,7	40,5	14	10	36,9
21 08 14	8	6	R1/4	11	20,7	22,7	43,5	14	10	36,3
21 10 14	10	8	R1/4	11	21	25,5	46,5	16	11	47,4
21 10 38	10	8	R3/8	11,5	22,5	25,5	48	16	11	51,2
21 12 38	12	10	R3/8	11,5	24,5	30	54,5	18	14	72,2
21 12 12	12	10	R1/2	14	28	30,5	58,5	18	17	99,1
21 15 12	15	12,5	R1/2	14	28	34	62	22	17	107,1

MC 22

十字型接头

Cross fitting

类型	OD1	ID1	L1	L2	H1	H2	g Δ
22 05 05	5	3	43	43	8	8	45,4
22 06 06	6	4	45	45	12	8	45,6
22 08 08	8	6	45	45	14	10	53,1
22 10 10	10	8	51	51	16	11	72,3

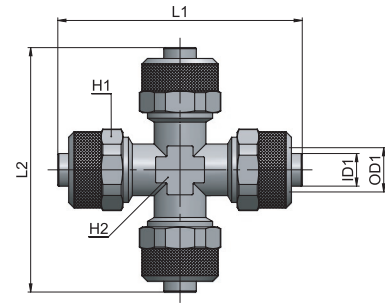

MC 23

单通铰接头本体

Single banjo ring

类型	OD1	ID1	D1	L1	L2	L3	H1	g Δ
23 04 M5	4	2,5	5,1	9	19	4,5	7	7,6
23 04 M5 /R	4	2,5	7	10	19	3,5	7	5,5
23 04 18	4	2,5	10	15	21,5	6	7	12,7
23 05 M5	5	3	5,1	9	20	4,5	8	7,3
23 05 M5 /R	5	3	7	10	20	3,5	8	6,5
23 05 18	5	3	10	15	23	6	8	20,5
23 06 M5	6	4	5,1	9	20	4,5	9	7,9
23 06 M5 /R	6	4	7	10	20	3,5	9	6,8
23 06 18	6	4	10	15	25	6	12	19,2
23 06 14	6	4	13,2	17	26,5	7,5	12	25,6
23 08 18	8	6	10	15	25	6	14	19,5
23 08 14	8	6	13,2	17	27,5	7,5	14	27,4
23 08 38	8	6	17	20	29,5	7,5	14	39,0
23 10 14	10	8	13,2	17	28,5	7,5	16	29,2
23 10 38	10	8	17	20	30,5	7,5	16	41,5

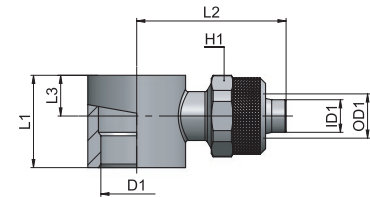

/R = 仅用于流量调节阀 - For flow controls only

MC 24

两通铰接头本体

Double banjo ring

类型	OD1	ID1	D1	L1	L2	L3	H1	g Δ
24 05 M5	5	3	5,1	9	40	4,5	8	12,0
24 06 M5	6	4	5,1	9	40	4,5	9	12,7
24 06 18	6	4	10	15	50	6	12	30,1
24 06 14	6	4	13,2	17	53	7,5	12	35,5
24 08 18	8	6	10	15	50	6	14	31,9
24 08 14	8	6	13,2	17	55	7,5	14	38,9
24 10 14	10	8	13,2	17	57	7,5	16	44,5

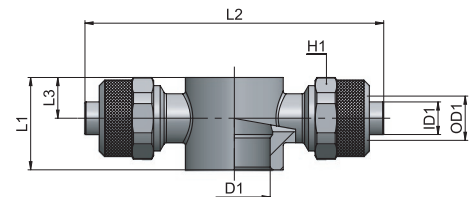

AP 55
AR 63
AV 221
CO 157
CX 255
EV 217
GU 119
GU Safety 135
GX 281
GX Safety 291
HP 317
MA 27
MB 41
MC 83
MF 235
MM 333
MO 93
MP 323
MT 339
MV 171
MX 241
MY 229
OX 261
PA 113
PE 79
PM 329
PN 67
PT 347
PU 131
PU Safety 149
PUX 287
PV 203
PVX 311
PX 249
QO 363
RA 101
RF 269
RT 355
RX 275
Tools 369
Tubings 375
VF 295
VT 359
VX 299

MC 27

螺母

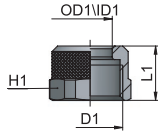

Nut

类型	OD1	ID1	D1	L1	H1	g
27 04 07	4	2,5	M6x0,75	8	7	1,1
27 05 08	5	3	M7x0,75	9	8	1,2
27 06 08	6	4	M8x0,75	9	9	1,5
27 06 10	6	4	M10x1	10	12	4,1
27 08 12	8	6	M12x1	10	14	5,0
27 10 14	10	8	M14x1	11,5	16	6,5
27 12 16	12	10	M16x1	13	18	8,8
27 15 20	15	12,5	M20x1	15,5	22	14,3

MC 29

可调向锥螺纹直接头

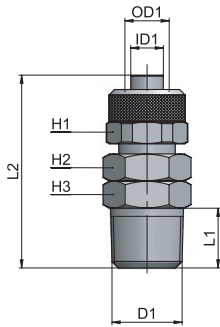

Swivelling taper straight

类型	OD1	ID1	D1	L1	L2	H1	H2	H3	g
29 06 18	6	4	R1/8	8	37	12	12	12	16,3
29 06 14	6	4	R1/4	11	40	12	14	14	27,2
29 08 18	8	6	R1/8	8	37	14	12	12	20,4
29 08 14	8	6	R1/4	11	40	14	14	14	30,6
29 10 14	10	8	R1/4	11	42	16	14	14	32,1

NBR 密封圈 - NBR Seals



-20°C ÷ 80°C



18 bar

MC 30

可调向单通铰接头

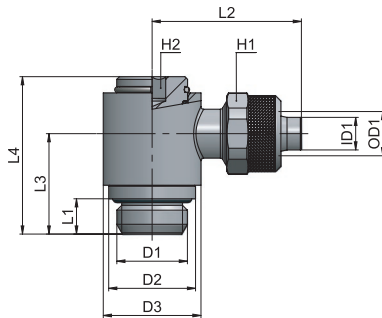

Swivelling fitting with banjo ring

类型	OD1	ID1	D1	D2	D3	L1	L2	L3	L4	H1	H2	g
30 06 18	6	4	G1/8	13	14	5	25	16,5	25,5	12	4	28,2
30 06 14	6	4	G1/4	16	18	6,5	26,5	18,5	29	12	5	41,9
30 08 18	8	6	G1/8	13	14	5	25	16,5	25,5	14	4	28,7
30 08 14	8	6	G1/4	16	18	6,5	27,5	18,5	29	14	5	44,7
30 10 14	10	8	G1/4	16	18	6,5	28,5	18,5	29	16	5	46,7
30 10 38	10	8	G3/8	20	22	7	30,5	22	32,5	16	6	68,7

NBR 密封圈 - NBR Seals



-20°C ÷ 80°C



18 bar

MC 31

可调向两通铰接头

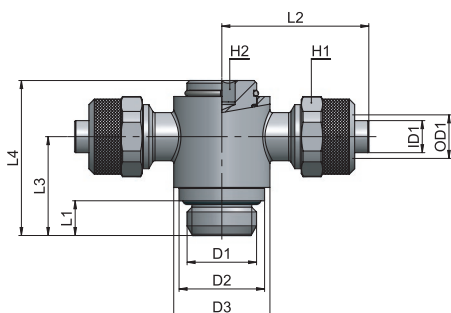

Swivelling fitting with double banjo ring

类型	OD1	ID1	D1	D2	D3	L1	L2	L3	L4	H1	H2	g
31 06 18	6	4	G1/8	13	14	5	25	16,5	25,5	12	4	39,2
31 06 14	6	4	G1/4	16	18	6,5	26,5	18,5	29	12	5	52,9
31 08 18	8	6	G1/8	14	14	5	25	16,5	25,5	14	4	41,2
31 08 14	8	6	G1/4	16	18	6,5	27,5	18,5	29	14	5	56,0
31 10 14	10	8	G1/4	16	18	6,5	28,5	18,5	29	16	5	64,0

NBR 密封圈 - NBR Seals



-20°C ÷ 80°C



18 bar

MC 32

带保护弹簧螺母

Nut with protection spring

类型	OD1	ID1	D1	L1	H1	g Δ
32 06 04	6	4	M10x1	95	12	13,3
32 08 06	8	6	M12x1	93,5	14	17,1
32 10 08	10	8	M14x1	96,5	16	30,4

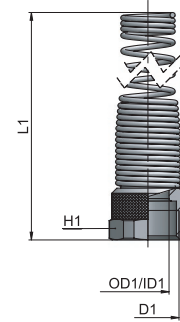

MC 34

可调向弯头

Swivelling elbow

类型	OD1	ID1	D1	L1	L2	L3	L4	H1	H2	g Δ
34 04 M5	4	2,5	M5x0,8	4,1	19	9,8	18,5	7	8	10,4
34 04 18	4	2,5	G1/8	4,4	21,5	15,2	27	7	14	27,5
34 05 M5	5	3	M5x0,8	4,1	20	9,8	18,5	8	8	10,0
34 05 18	5	3	G1/8	4,4	23	15,2	27	8	14	27,0
34 06 M5	6	4	M5x0,8	4,1	20	9,8	18,5	9	8	10,8
34 06 18	6	4	G1/8	4,4	25	15,2	27	12	14	32,5
34 06 14	6	4	G1/4	5,9	26,5	17,2	31,5	12	17	52,4
34 08 18	8	6	G1/8	4,4	25	15,2	27	14	14	33,6
34 08 14	8	6	G1/4	5,9	27,5	17,2	31,5	14	17	54,6
34 08 38	8	6	G3/8	6,4	29,5	20,7	36	14	20	83,4
34 10 14	10	8	G1/4	5,9	28,5	17,2	31,5	16	17	56,7
34 10 38	10	8	G3/8	6,4	30,5	20,7	36	16	20	86,2

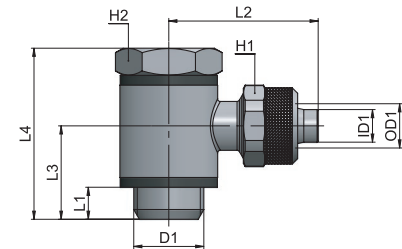

PA6 密封垫片 - PA6 Sealing ring

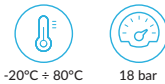

MC 36

可调向T型接头

Swivelling T

类型	OD1	ID1	D1	L1	L2	L3	L4	H1	H2	g Δ
36 05 M5	5	3	M5x0,8	4,1	20	9,8	18,5	8	8	14,3
36 06 M5	6	4	M5x0,8	4,1	20	9,8	18,5	9	8	15,3
36 06 18	6	4	G1/8	4,4	25	15,2	27	12	14	44,1
36 06 14	6	4	G1/4	5,9	26,5	17,2	31,5	12	17	63,2
36 08 18	8	6	G1/8	4,4	25	15,2	27	14	14	46,3
36 08 14	8	6	G1/4	5,9	27,5	17,2	31,5	14	17	66,5
36 10 14	10	8	G1/4	5,9	28,5	17,2	31,5	16	17	72,4

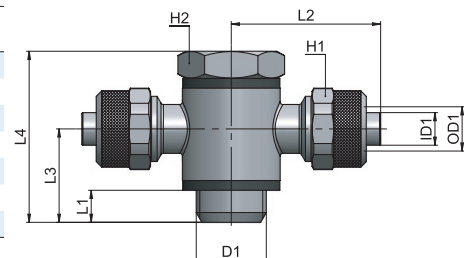

PA6 密封垫片 - PA6 Sealing ring

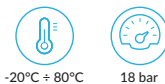

AP 55
AR 63
AV 221
CO 157
CX 255
EV 217
GU 119
GU Safety 135
GX Safety 281
GX Safety 291
HP 317
MA 27
MB 41
MC 83
MF 235
MM 333
MO 93
MP 323
MT 339
MV 171
MX 241
MY 229
OX 261
PA 113
PE 79
PM 329
PN 67
PT 347
PU 131
PU Safety 149
PUX 287
PV 203
PVX 311
PX 249
QO 363
RA 101
RF 269
RT 355
RX 275
Tools 369
Tubings 375
VF 295
VT 359
VX 299



cmatic