



MY LINE



CN

PPSU材质快插式管接头

MY系列管接头已通过NSF/ANSI 169认证，可安全接触水、茶和咖啡等饮品，并符合欧盟1935/2004号法规（食品接触材料）要求。该系列接头采用PPSU材料制成，这种高性能热塑性聚合物以其卓越的耐热性、耐化学性与机械强度而著称，是食品饮料、工业及医疗应用的理想选择。PPSU卓越的耐化学腐蚀特性使MY系列产品具备极长的使用寿命，能持续保持最佳性能稳定性，彻底杜绝污染风险与不良反应隐患。

EN

PPSU Push-in fittings

MY range of fittings is 169 NSF/ANSI certified for contact with water, tea and coffee. It is also compliant with EU 1935/2004 Regulation (MOCA). MY line of fittings is made of PPSU (Polyphenylsulfone), a high-performance thermoplastic polymer, well-known for its excellent thermal, chemical and mechanical properties that make it an excellent choice for Food and Beverage, industrial and medical applications. Especially the exceptional chemical and corrosion resistance of PPSU enables the MY line to ensure maximum durability, optimal performance consistency, complete absence of contamination and unwanted chemical reactions risks.

MY Line

- | | | | | | |
|---|-------------------------------|--|--|---|--|
| <p>1 本体
Body</p> <p>PPSU
PPSU</p> | <p>2 释放环
Release ring</p> | <p>3 螺纹
Thread</p> <p>316L 不锈钢
Stainless steel AISI 316L</p> | <p>4 卡爪
Gripping ring</p> <p>AISI 301 不锈钢
Stainless steel AISI 301</p> | <p>5 保护环
Protection Ring</p> <p>PEI
PEI</p> | <p>6 密封圈
Seals</p> <p>满足FDA规范的FPM
FPM, FDA compliant</p> |
|---|-------------------------------|--|--|---|--|



0°±140°C



20 bar @ 20°C



-99 KPa

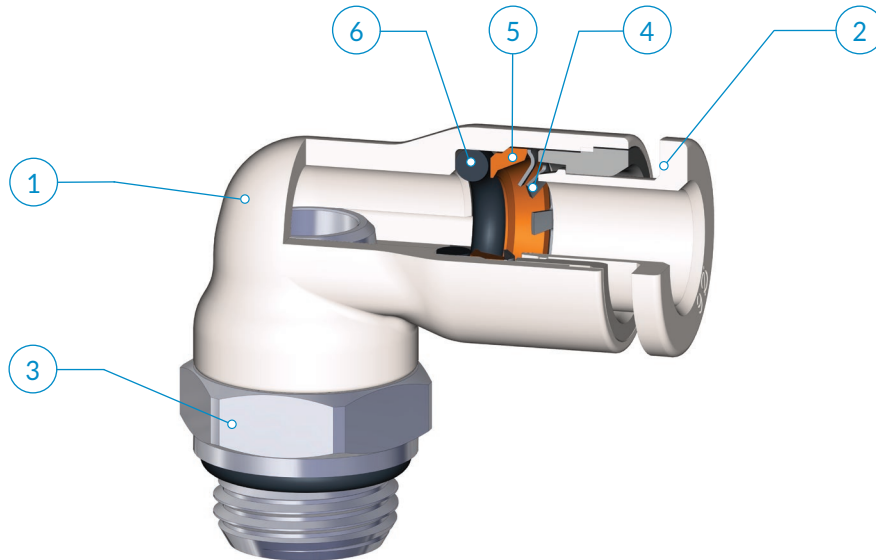

	G1/8	G1/4
4	●	●
6	●	●
8	●	●

建议的连接管路:
食品饮料行业合规管路

Recommended tubings:
Tubing recommended for Food and Beverage

可接受的管路公差:
+/- 0.07 mm, 最大直径Ø 8 mm。

Acceptable Tolerances on the tubings:
+/- 0.07 mm up to Ø 8 mm.

应用领域:
食品和饮料行业, 热水, 咖啡, 蒸汽

Application fields:
Food&Beverage, Hot water, Coffee, Steam

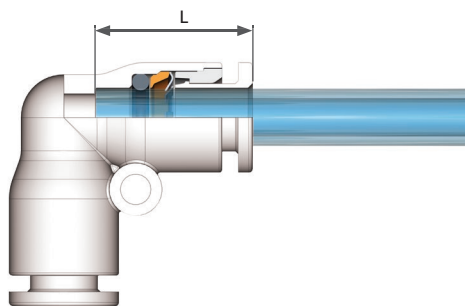

OD	L
4	13,4
6	16,3
8	16,5

i 安装说明

ASSEMBLY INSTRUCTIONS

1

沿管路垂直切割 (使用TCUT切管刀),确认内外管壁没有毛刺,同时注意避免管路截面呈椭圆形。使用金属管路连接时,需要通过专用设备 (TINC) 在管路上开槽。开槽尺寸需要考虑管路直径,以保证可靠的连接。

1

Cut the tube square (by means of a hose cutter i.e. our TCUT) making sure that no burrs are left and that the tube is not oval. In case of use with metal hoses, make a groove all around the tube diameter with a suitable tool (TINC).The groove must be made according to the tube diameter so that the fitting collect can better grip onto it.

2

将管路插入接头,到底为止。

2

Insert the tube into the fitting until it bottoms.

拔出管路:

垂直按压释放环,同时拔出管路即可。

Tube release

While pressing on the release ring, pull out the tube from the fitting

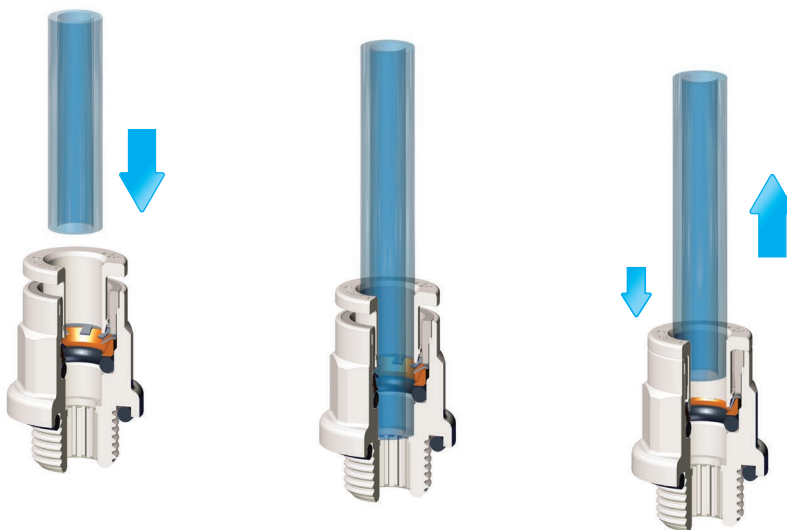

完成连接后,请确保管路上不承受外力;此外,请确保管路连接的最小弯曲半径符合本样册第376页之规定。

为了避免管路意外松脱,任何物体均不要接触释放环。作用在释放环上任何外力,包括侧向力,均可能导致管路意外松脱。螺纹拧紧时,请参考第10页列出的建议扭矩。



Once the tubing is connected to the fitting, make sure that the tubing is not subject to any tensile strength and that the min. recommended bending radius stated in the tubing section of this catalogue is complied with (see page 376).

To prevent any accidental tube release, no components have to come in touch with the release ring and exercise any unwanted pressure on the same. Indeed however lateral, any load on the release ring may cause the tube disconnection.

To tighten threads, please check out our tightening torque chart illustrated at page 10.

MY 12

外直螺纹直接头

Parallel straight, male

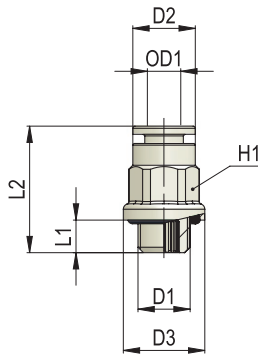

类型	OD1	D1	D2	D3	L1	L2	H1	g Δ
12 04 18	4	G1/8	9,5	15	6	20	10	1,9
12 06 18	6	G1/8	11,5	15	6	23	12	2,4
12 06 14	6	G1/4	11,5	18	7	21	12	-

MY 16

可调向外直螺纹弯管接头

Parallel swivelling elbow fitting, male

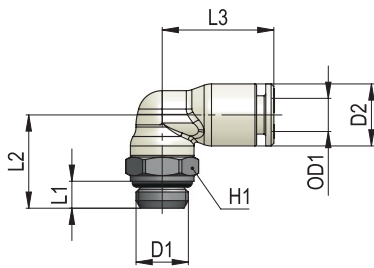

类型	OD1	D1	D2	L1	L2	L3	H1	g Δ
16 04 18 -X	4	G1/8	9,5	5	15	16	12	5,8
16 04 14 -X	4	G1/4	9,5	6,5	17	16	15	9,6
16 06 18 -X	6	G1/8	11,5	5	17,3	20,5	12	7,8
16 06 14 -X	6	G1/4	11,5	6,5	19,3	20,5	15	10,4
16 08 18 -X	8	G1/8	14	5	18	21,5	12	-
16 08 14 -X	8	G1/4	14	6,5	20	21,5	15	-

MY 21

可调向直螺纹正T型三通接头

Swivelling T fitting, parallel

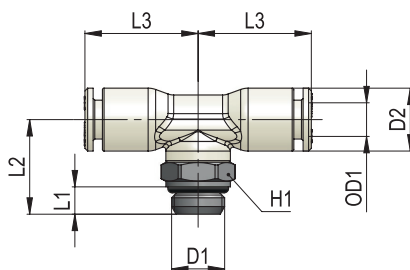

类型	OD1	D1	D2	L1	L2	L3	H1	g Δ
21 04 18 -X	4	G1/8	9,5	5	15	16	12	6,8
21 04 14 -X	4	G1/4	9,5	6,5	17	16	15	10,4
21 06 18 -X	6	G1/8	11,5	5	17,3	20,5	12	8,9
21 06 14 -X	6	G1/4	11,5	6,5	19,3	20,5	15	12,9

MY 26

对接接头

Union

类型	OD1	OD2	D2	L1	g 
26 04 04	4	4	9,5	27,5	1,7
26 06 04	6	4	11,5	30,6	-
26 06 06	6	6	11,5	33,7	2,7
26 08 08	8	8	14	34,3	-

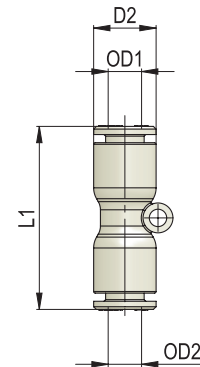

MY 28

直角对接接头

Union elbow

类型	OD1	D2	L1	g 
28 04 04	4	9,5	15,5	1,8
28 06 06	6	11,5	19,5	3,0
28 08 08	8	14	21	-

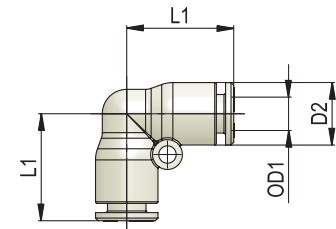

MY 29

正T型三通对接接头

Union T

类型	OD1	D2	L1	g 
29 04 04	4	9,5	15,5	2,7
29 06 06	6	11,5	19,5	4,4
29 08 08	8	14	21	-

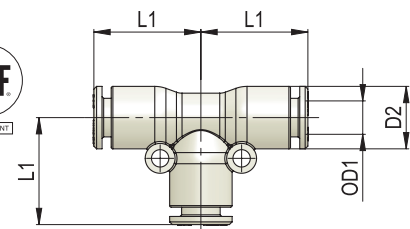

AP 55
AR 63
AV 221
CO 157
CX 255
EV 217
GU 119
GU Safety 135
GX 281
GX Safety 291
HP 317
MA 27
MB 41
MC 83
MF 235
MM 333
MO 93
MP 323
MT 339
MV 171
MX 241
MY 229
OX 261
PA 113
PE 79
PM 329
PN 67
PT 347
PU 131
PU Safety 149
PUX 287
PV 203
PVX 311
PX 249
QO 363
RA 101
RF 269
RT 355
RX 275
Tools 369
Tubings 375
VF 295
VT 359
VX 299

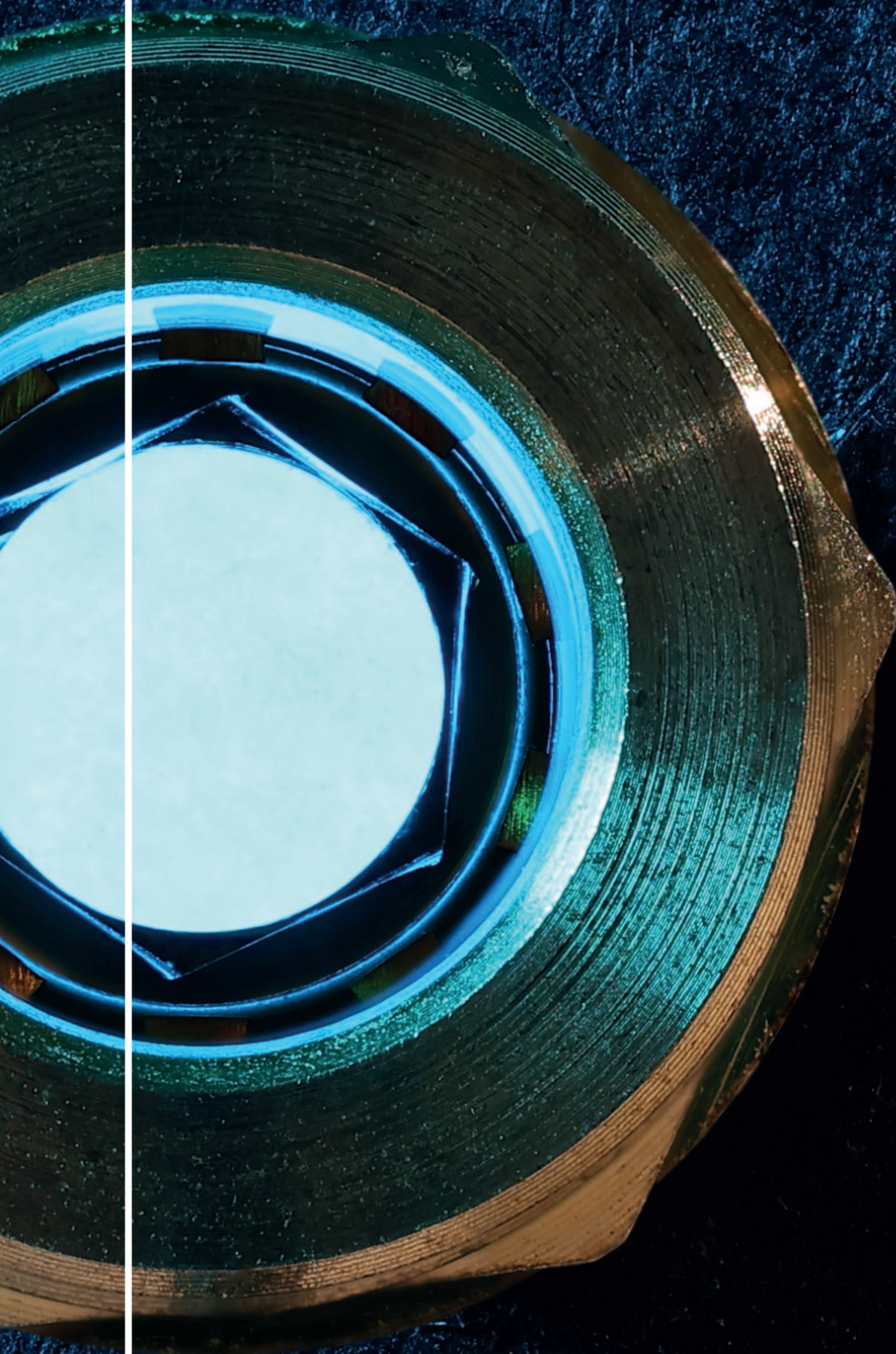

cmatic