

VF LINE



IT

适用于食品与饮料行业的功能接头

VF系列是专为食品饮料应用设计的功能接头。该系列采用低铅黄铜制造（铅含量<0.1%），通过NSF/ANSI 169认证，可安全接触水、茶和咖啡等饮品，这使其成为咖啡设备和自动售卖机行业的理想解决方案。VF接头同时符合NSF/ANSI 372标准对饮用水接触材料含铅量的限定要求（铅含量<0.1%），满足美国《安全饮用水法案》规定，并全面符合ROHS III指令环保标准。

EN

Function Fittings for Food and Beverage Applications

VF is a function fitting designed for food and beverage applications. The VF fittings are made of low lead brass (Pb<0,1%) and they are certified NSF/ANSI 169 for contact with water, tea and coffee. This makes the VF line the right solution for the coffee and vending machines industry. The VF fitting also boasts the NSF/ANSI 372 compliance to brass maximum allowed lead content standards (Pb<0,1%) for use in contact with drinking water (U.S. Safe Drinking Water Act). VF fittings are meeting the ROHS III Directive.

VF 21

线型节流阀

In-line flow control

- 1 本体
Body
- 2 针阀
Needle valve
- 3 旋钮
Handwheel
- 4 阀针
Needle
- 5 螺母
Nut

- 6 密封圈
Seals

黄铜 UNI EN 12164 CW510N
Brass UNI EN12164 CW510L

满足FDA规范的FPM
FPM, FDA compliant



-20° ÷ 150°C



10 bar

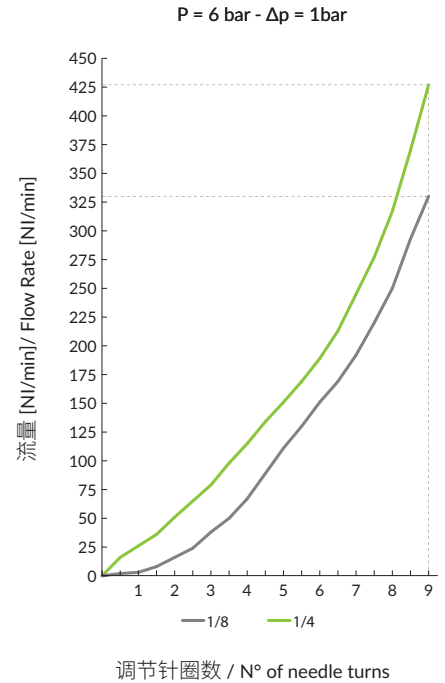
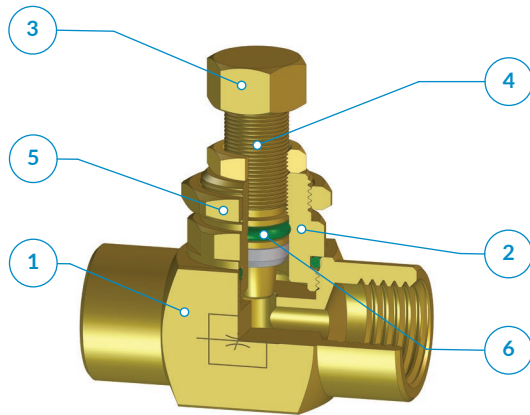

涉及蒸汽应用, 请联络销售技术团队。
For steam applications, please contact our sales engineering team.

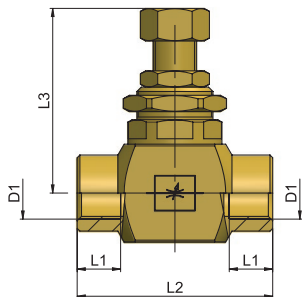

类型	D1	L1	L2	L3 max	g	g
21 18 18	G1/8	8	36	34	79,1	
21 14 14	G1/4	9	41	34	86,5	

.../B =



建议的连接管路:
食品饮料行业合规管路

Recommended tubings:
Tubing recommended for Food and Beverage

可接受的管路公差:
+/- 0.07 mm, 最大直径Ø 8 mm。

Acceptable Tolerances on the tubings:
+/- 0.07 mm up to Ø 8 mm.

应用领域:
食品和饮料领域应用。

Application fields:
Food&Beverage

VF 25

手动两通球阀

2 way manual valve

1 本体
Body

2 手柄
Handle

黄铜UNI EN 12164 CW510N
Brass UNI EN12164 CW510L

3 垫圈
Gasket

PTFE
PTFE

4 密封圈
Seals

满足FDA规范的FPM
FPM compliant with FDA



-20° ÷ 150°C



2 ÷ 10 bar



1/8	6 mm
1/4	6 mm
3/8	8 mm
1/2	10 mm

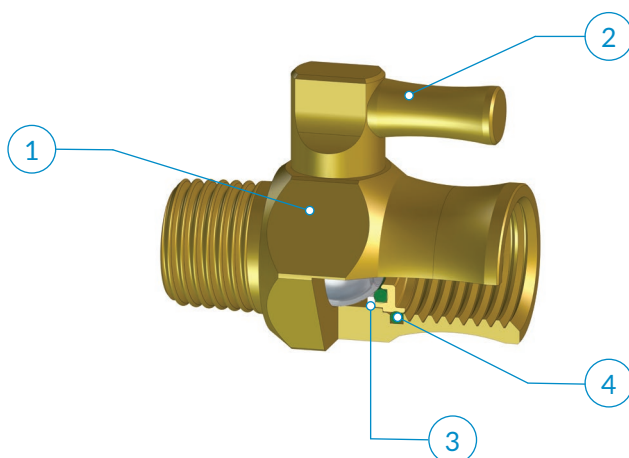

类型	D1	D2	L1	L2	L3	L4	L5	L6	H1	g	g
25 00 18	G1/8	R1/8	8	19	32,8	17	19	7,5	18	45,3	
25 00 14	G1/4	R1/4	9	19	35,9	17	19	11	18	43,6	

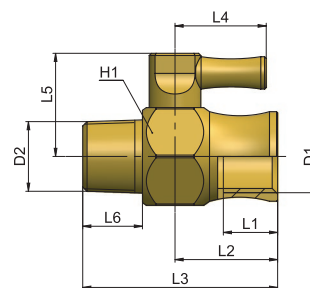

建议的连接管路:
食品饮料行业合规管路

Recommended tubings:
Tubing recommended for Food and Beverage

可接受的管路公差:
+/- 0.07 mm, 最大直径Ø 8 mm。

Acceptable Tolerances on the tubings:
+/- 0,07 mm up to Ø 8 mm.

应用领域:
食品和饮料领域应用。

Application fields:
Food&Beverage

VF 33T

单向阀

Check valve

- 1 本体
Body
- 2 阀芯
Valve

黄铜 UNI EN 12164 CW510N
Brass UNI EN 12164 CW510L

- 3 密封圈
Seals

满足 FDA 规范的 FPM
FPM compliant with FDA

- 4 弹簧
Spring

AISI 302 不锈钢
Stainless steel AISI 302

- 5 MF 快插接头
MF line push-in fittings



-20° ÷ 150°C



2÷10 bar



0,2 bar

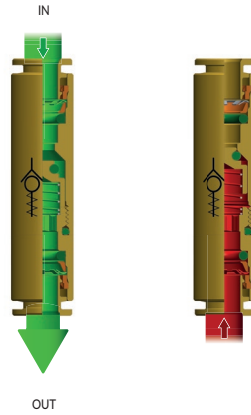
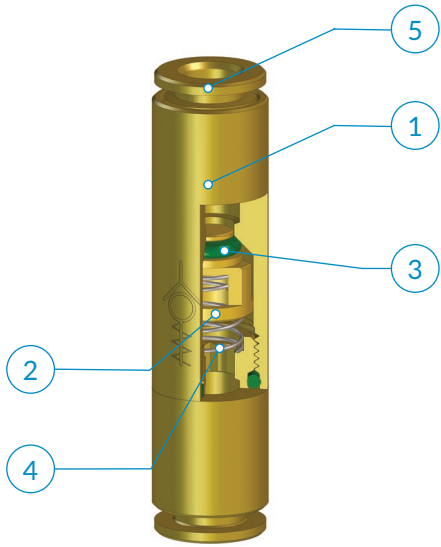

P = 6 bar - Δp = 1bar

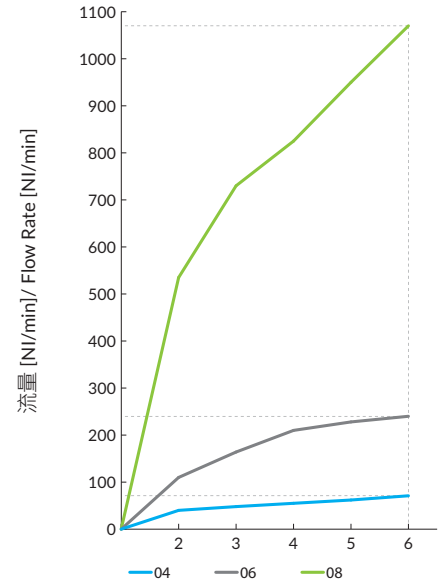

流量 [NI/min] / Flow Rate [NI/min]

压力 [Bar] / Pressure [Bar]

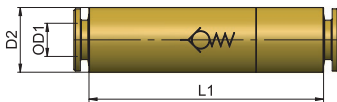

类型	OD1	D2	L1	g ΔΔ
33 04 04 T	4	9	40,9	11,8
33 06 06 T	6	12	48,5	25,2
33 08 08 T	8	14	48,9	20,8

i 流体仅允许单向通过 (沿着阀体上箭头方向), 反向截止。

i The flow is allowed only in one way (the arrow direction engraved on the body) and stopped in the reverse way.

建议的连接管路:
食品饮料行业合规管路

Recommended tubings:
Tubing recommended for Food and Beverage

可接受的管路公差:
+/- 0.07 mm, 最大直径 Ø 8 mm。

Acceptable Tolerances on the tubings:
+/- 0,07 mm up to Ø 8 mm.

应用领域:
食品和饮料领域应用。

Application fields:
Food&Beverage