



MM LINE



Misting Push-in Fittings, 1,160 PSI Inch/NPTF

MM is a misting fittings line.

Cmatic are now using all their know-how and experience in high pressure connections for a completely new purpose. To create "Misting".

Water at 1,160 PSI pressure is channelled through hoses and sprayed by nozzles as millions of very fine mist drops, creating a refreshing effect all around a specific area.

Misting, as a cost effective, energy saving and non polluting technique is used both in industrial and commercial fields to control odours and humidity, to set dusts, to cool down indoor and outdoor temperatures.

MM Line

1

Body

Brass UNI EN 12164 CW614N - UNI EN 12165 CW617N, nickel plated

2

Gripping ring

Brass UNI EN 12164 CW614N, nickel plated

3

Seals

NBR



-4° ÷ 176°F



Max 1,160 PSI

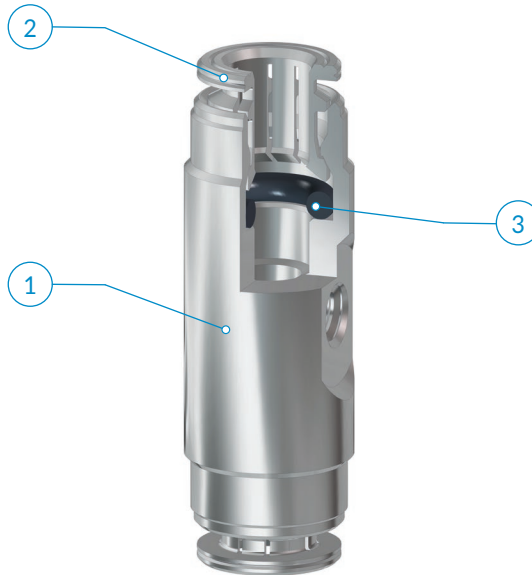

	1/4 NPTF	3/8 NPTF	1/2 NPTF	G1/4
1/4	•			•
3/8	•	•		•
1/2			•	

Recommended tubings:
PA12 HR

Acceptable Tolerances on the tubings:
+/- .003 up to Ø 3/8"
+/- .004 up to Ø 1/2"

Application fields:
Misting circuits

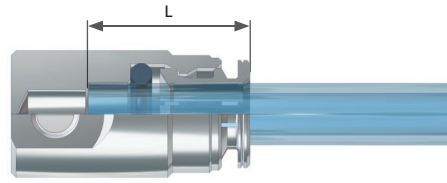

OD	L
1/4	.669
3/8	.728
1/2	.803

i ASSEMBLY INSTRUCTIONS

1

Cut the tube square (by means of a hose cutter i.e. our TCUT) making sure that no burrs are left and that the tube is not oval.

2

Insert the tube into the fitting until it bottoms.

Tube release

While pressing on the release ring, pull out the tube from the fitting.

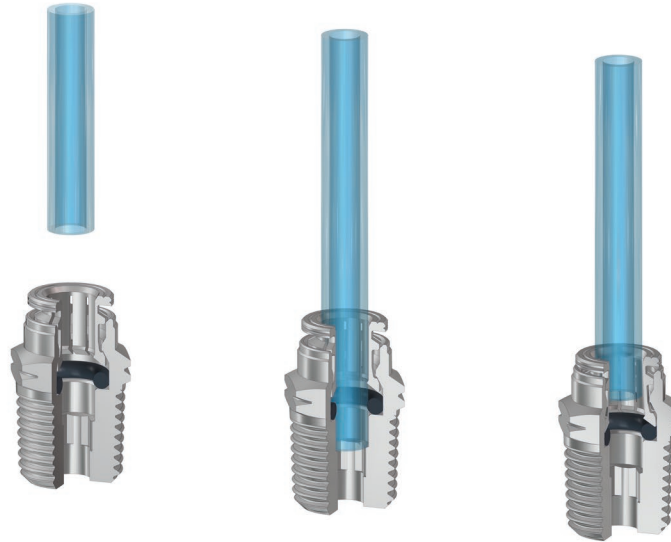

Once the tubing is connected to the fitting, make sure that the tubing is not subject to any tensile strength and that the min. recommended bending radius stated in the tubing section of this catalogue is complied with (see page 136).

To prevent any accidental tube release, no components have to come in touch with the release ring and exercise any unwanted pressure on the same. Indeed however lateral, any load on the release ring may cause the tube disconnection.

To tighten threads, please check out our tightening torque chart illustrated at page 6.

MM 11

Taper straight, male

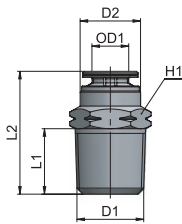

Type	OD1	D1	D2	L1	L2	H1	oz
11 1/4 1/4	1/4	1/4 NPTF	.472	.512	.965	14	.586
11 3/8 1/4	3/8	1/4 NPTF	.622	.512	1.142	16	.688
11 3/8 3/8	3/8	3/8 NPTF	.630	.512	1.102	18	1.063
11 1/2 1/2	1/2	1/2 NPTF	.748	.669	1.299	22	1.863

MM 12

Parallel straight, male

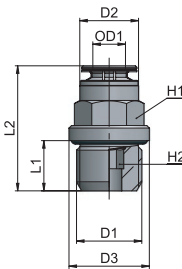

Type	OD1	D1	D2	D3	L1	L2	H1	H2	oz
12 1/4 G1/4	1/4	G1/4	.461	.630	.394	.980	12	5	.558
12 3/8 G1/4	3/8	G1/4	.622	.650	.394	1.228	15	7	.766

MM 26

Union

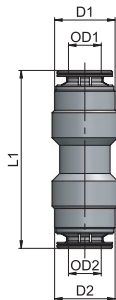

Type	OD1	OD2	D1	D2	L1	oz
26 1/4 1/4	1/4	1/4	.472	.472	1.398	.600
26 1/4 3/8	1/4	3/8	.472	.630	1.476	.851
26 3/8 3/8	3/8	3/8	.630	.630	1.520	.946
26 3/8 1/2	3/8	1/2	.669	.768	1.626	1.351
26 1/2 1/2	1/2	1/2	.768	.768	1.693	1.408

MM 28

Union elbow

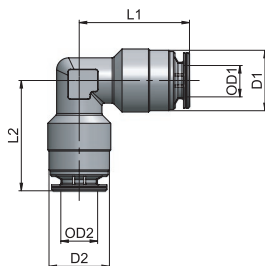

Type	OD1	OD2	D1	D2	L1	L2	oz
28 1/4 1/4	1/4	1/4	.472	.472	.866	.866	.635
28 3/8 3/8	3/8	3/8	.630	.630	1.004	1.004	1.239
28 1/2 1/2	1/2	1/2	.768	.768	1.161	1.161	2.043

MM 29

Union T

Type	OD1	OD2	D1	D2	L1	L2	oz 
29 1/4 1/4	1/4	1/4	.472	.472	.827	.827	.822
29 3/8 3/8	3/8	3/8	.630	.630	.984	.984	1.674
29 1/2 3/8	1/2	3/8	.768	.630	1.122	1.063	2.561
29 1/2 1/2	1/2	1/2	.768	.768	1.122	1.122	2.579

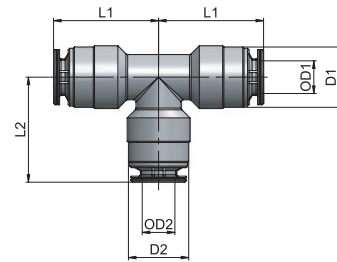

- CO 67
- MA 31
- MM 115
- PA 49
- PE 45
- PM 111
- PN 19
- PT 121
- PU 55
- PU Safety 59
- PUX 101
- PV 81
- PVX 105
- PX 95
- Tool 129
- Tubings 135

MM 40

Terminal

Type	OD1	D1	L1	oz 
40 00 1/4	1/4	.472	.768	.420
40 00 3/8	3/8	.630	.846	.699
40 00 1/2	1/2	.768	.965	1.034

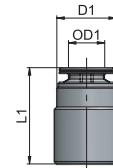

MM 46

Cross fitting

Type	OD1	D1	L1	oz 
46 1/4 1/4	1/4	.472	.866	1.468
46 3/8 3/8	3/8	.630	1.004	2.152

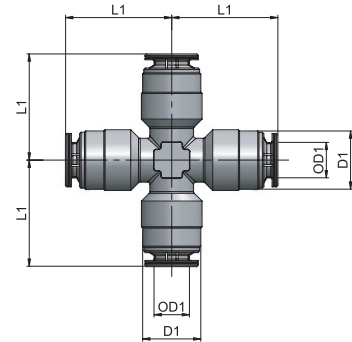

MM 60

Union with nozzle port

Type	OD1	OD2	D1	D2	L1	oz 
60 1/4 1/4	1/4	1/4	.472	.472	1.555	.819
60 3/8 3/8	3/8	3/8	.630	.630	1.732	1.457

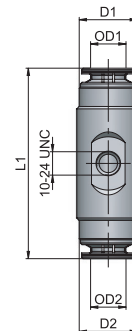

MM 61

Terminal with nozzle port

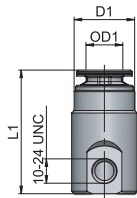

Type	OD1	D1	L1	oz
61 00 1/4	1/4	.472	.965	.562
61 00 3/8	3/8	.630	1.043	.896

MM 99

Nozzle



Type	D1	D2	oz
99 10-24 ø0,15	10-24 UNF	.006	.350
99 10-24 ø0,20	10-24 UNF	.008	.350
99 10-24 ø0,30	10-24 UNF	.012	.350
99 10-24 ø0,40	10-24 UNF	.016	.350



The nozzles with hole 0.15 and 0.20 are generally used for cooling purposes (both in civil and in animal applications), while 0.30 and 0.40 are used primarily for dust, odors suppression and for moisturizing.

Water flow rate per nozzle size and water pressure

orifice size in mm	35 bar 500 psi	45 bar 640 psi	70 bar 1000 psi	84 bar 1200 psi	
.006	0,0330 0,0087	0,0380 0,0100	0,0460 0,0122	0,0510 0,0133	l/min USGpm
.008	0,0568 0,0153	0,0643 0,0175	0,0787 0,0208	0,0980 0,0258	l/min USGpm
.012	0,0790 0,0205	0,0867 0,0235	0,1080 0,0290	0,1590 0,0420	l/min USGpm
.0160	0,1048 0,0282	0,1190 0,0322	0,1483 0,0398	0,1950 0,0515	l/min USGpm