

BuzziShield Light

INSTALLATION MANUAL

220-240V

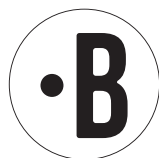
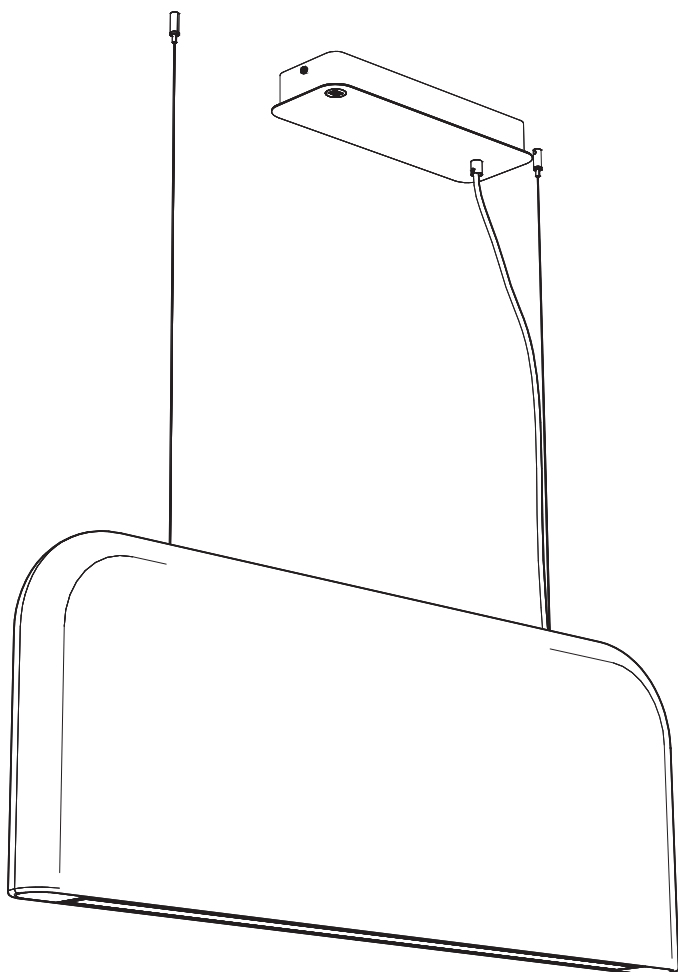

Technical info

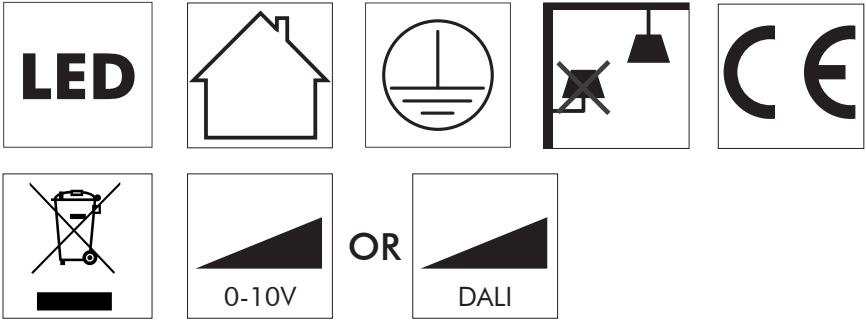

Environmental Protection

Waste electrical products should not be disposed of with household waste. Please recycle where facilities exist. Check with your Local Authority or retailer for recycling advice.

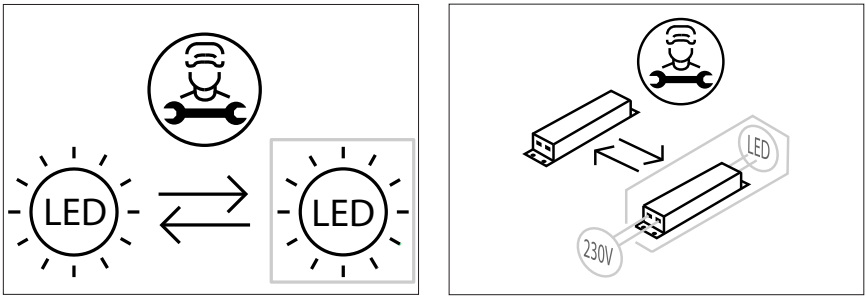

⚠ The light source contained in this luminaire shall only be replaced by the manufacturer or his service agent or a similar qualified person.

⚠ The control terminals of LED driver need to use SELV control signal.

⚠ If the external flexible cable or cord of this luminaire is damaged, it shall be exclusively replaced by the manufacturer or his service agent or a similar qualified person in order to avoid a hazard."

Included

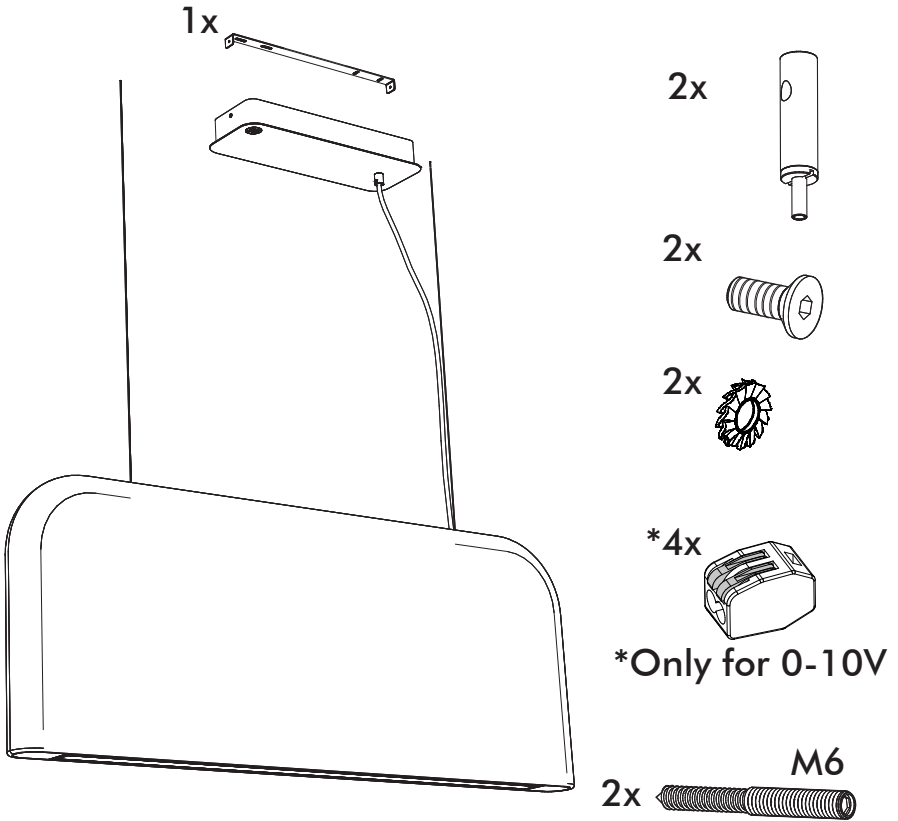

Excluded

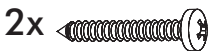
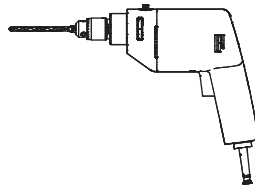
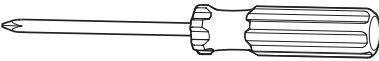
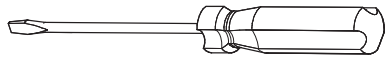

BuzziShield Light

2 PERS. 

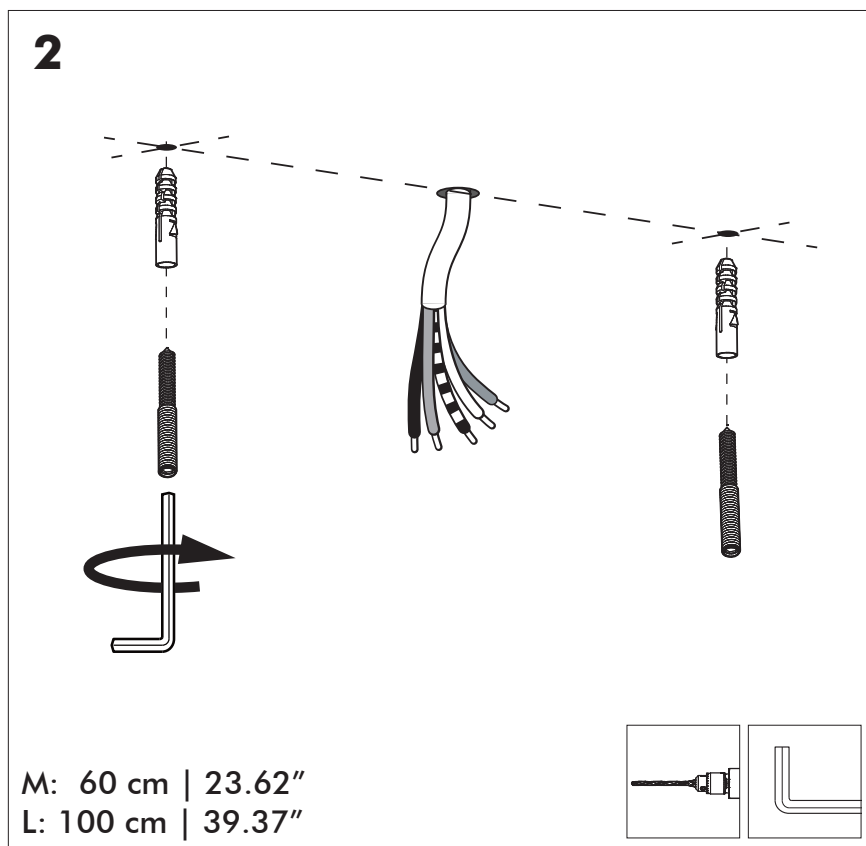
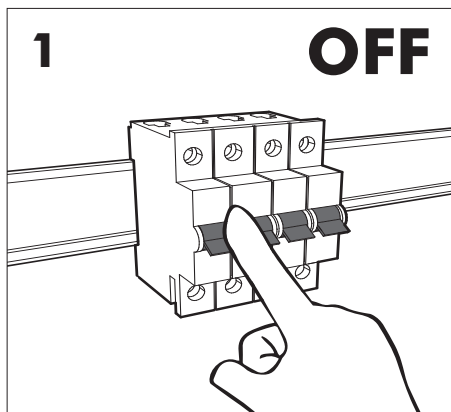

3

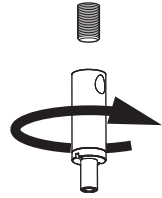
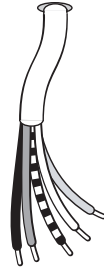
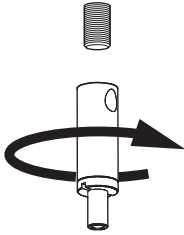

4

2x

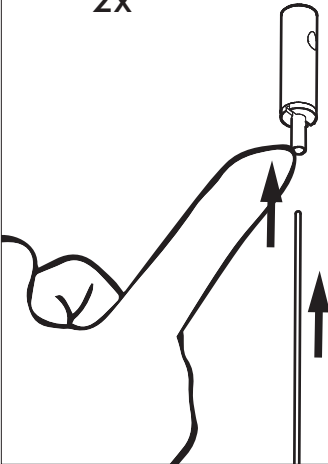

2x

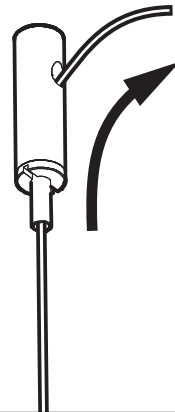

5

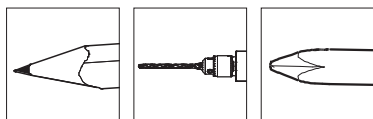
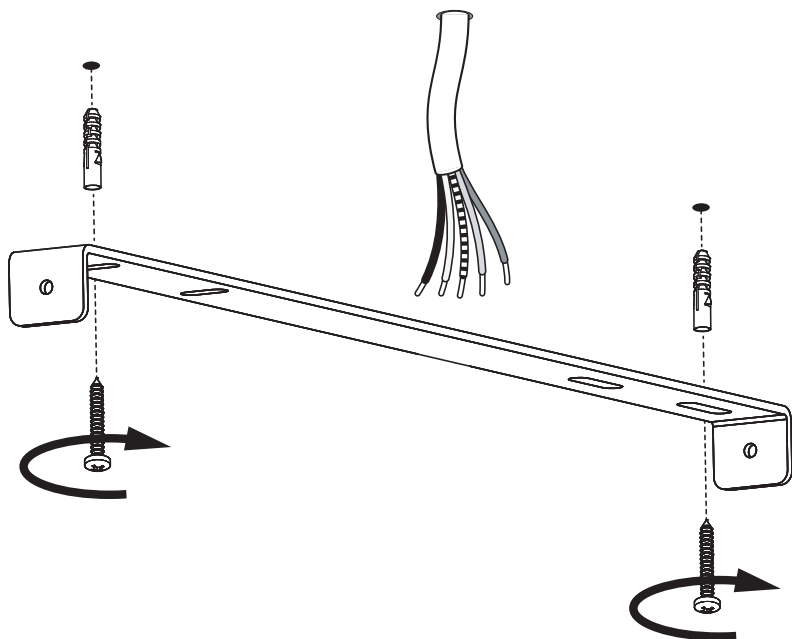

6

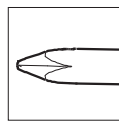
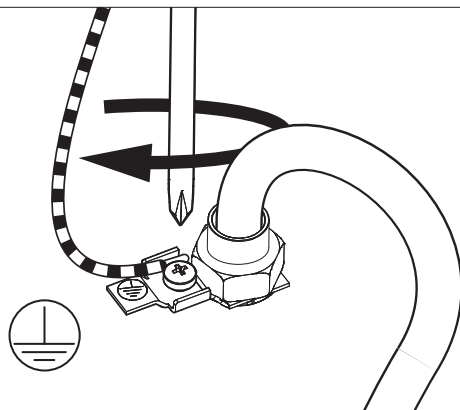

7a

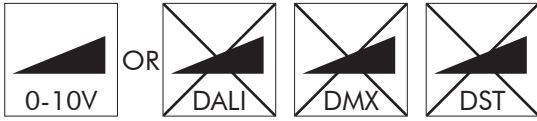

Connection including dimmable function

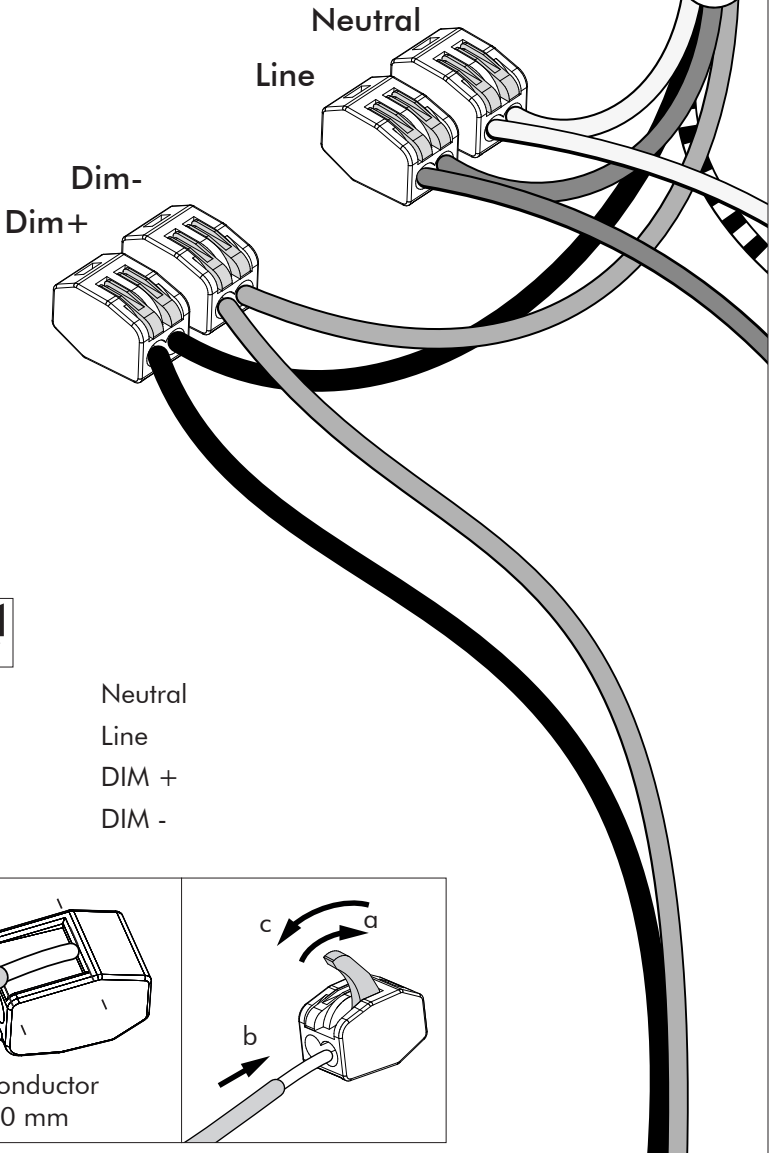

- | | |
|--------|---------|
| Blue | Neutral |
| Brown | Line |
| Purple | DIM + |
| Pink | DIM - |

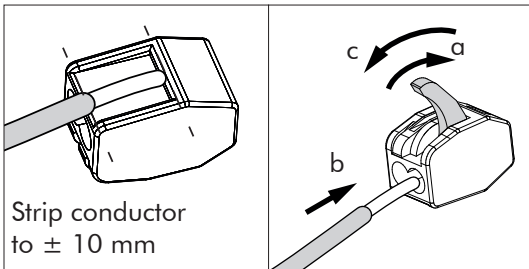

7b



Connection including dimmable function

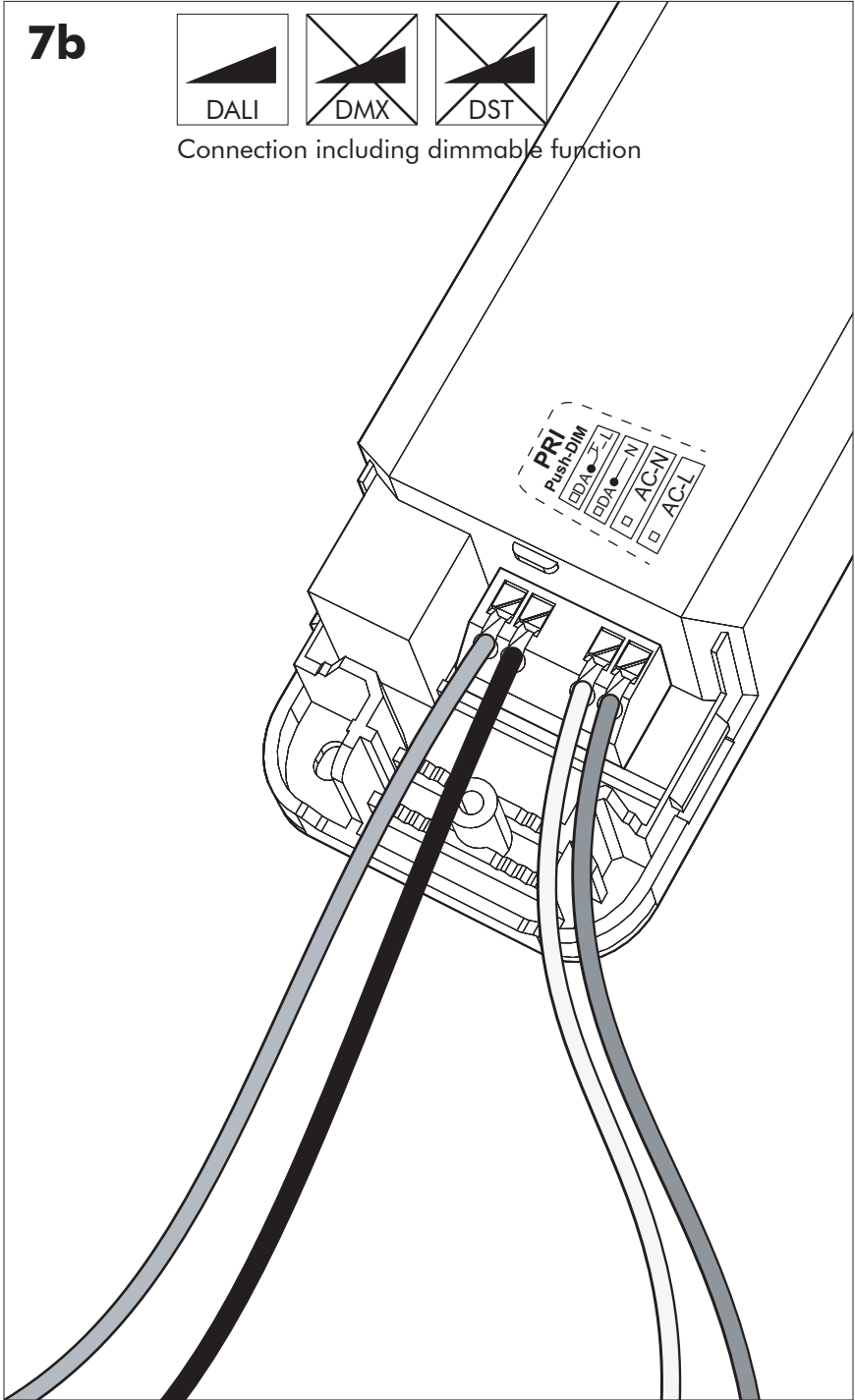

8

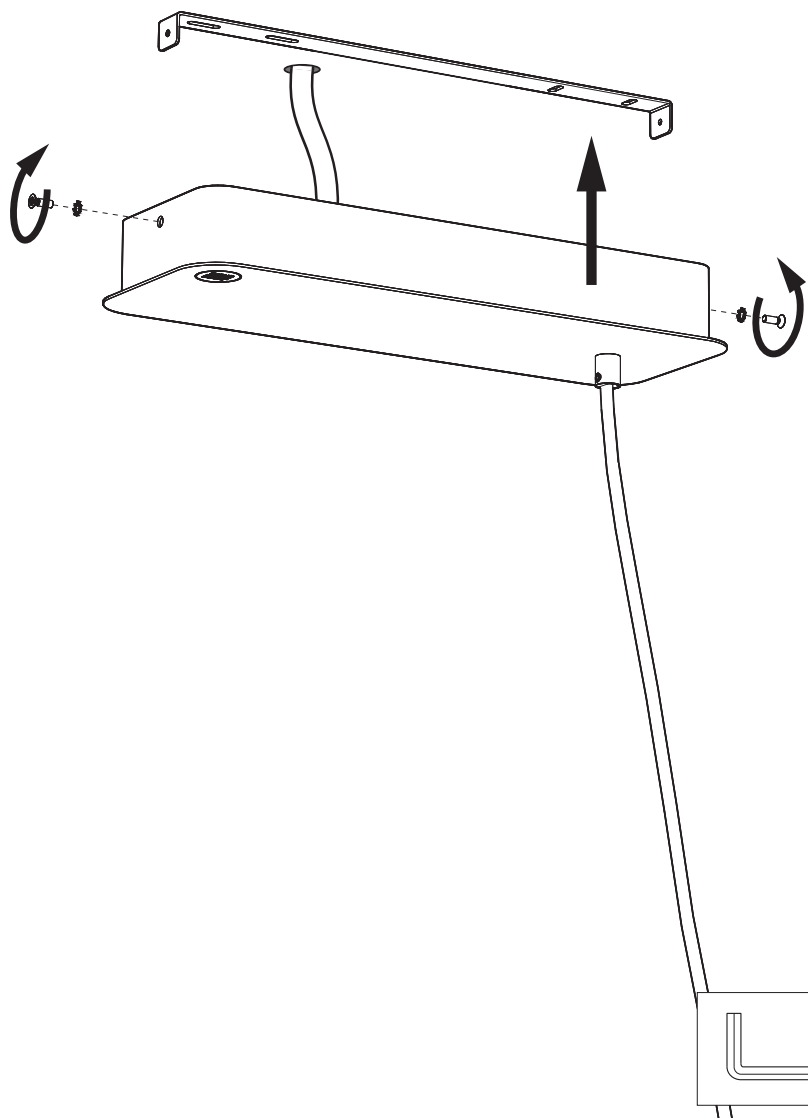

9

!

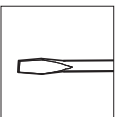
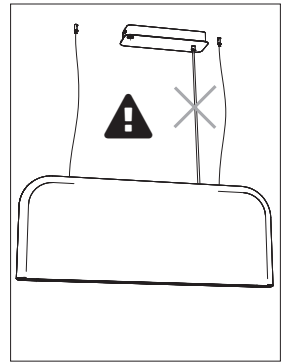
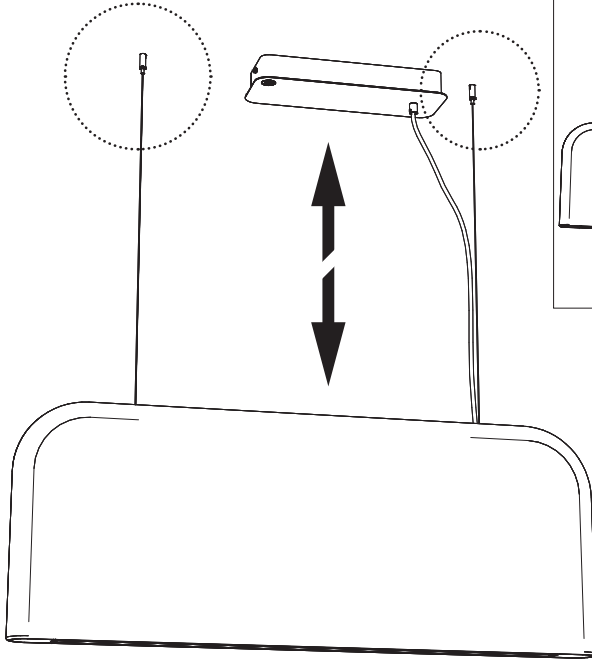
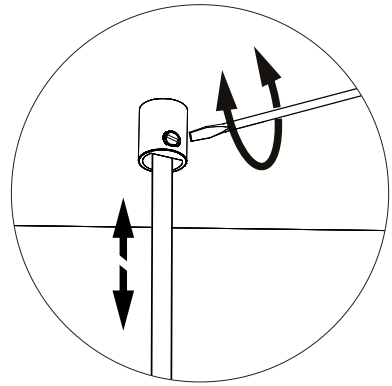
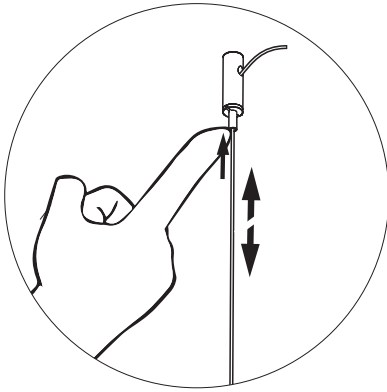

BuzziSpace Group NV
Italiëlei 8, 2000 Antwerp
Belgium

☎ +32 (0)3 846 10 00

✉ info@buzzi.space

🌐 www.buzzi.space

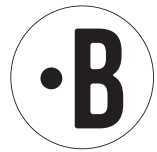

A-0000007476/02
Last update: 30/11/2023