

BuzziJet Ceiling Mounted

INSTALLATION MANUAL

220-240V

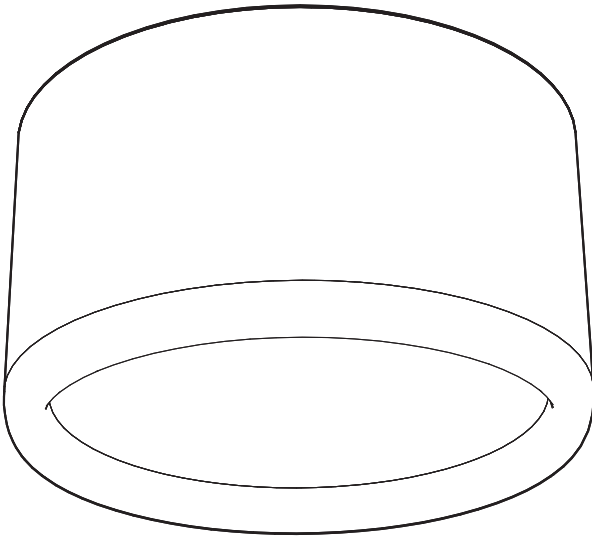

Technical info

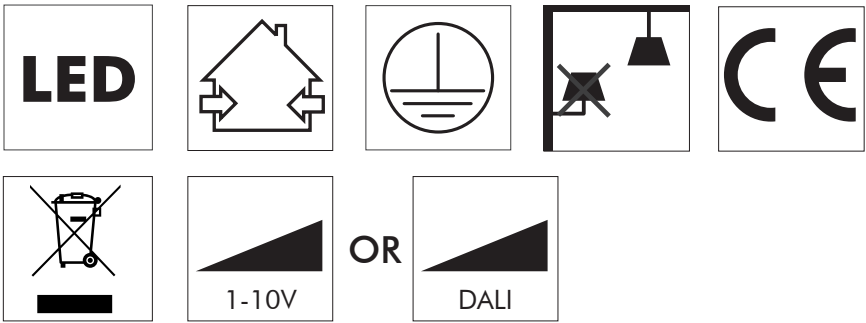

Environmental Protection

Waste electrical products should not be disposed of with household waste. Please recycle where facilities exist. Check with your Local Authority or retailer for recycling advice.

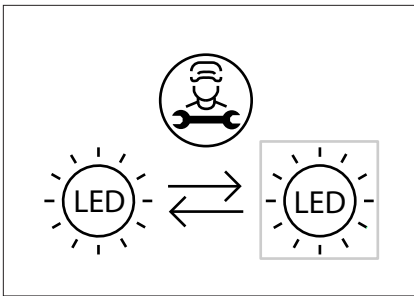

Replaceable (LED only) light source by a professional.

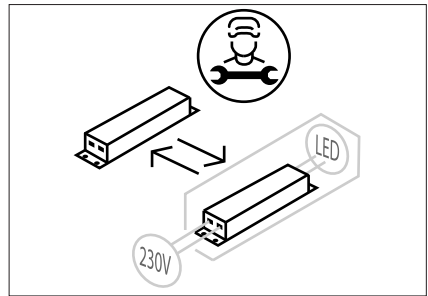

Replaceable control gear by a professional

Excluded

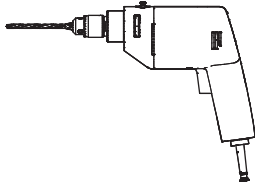
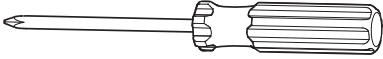

Included BuzziJet Ceiling Mounted

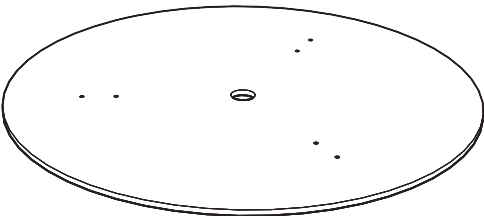
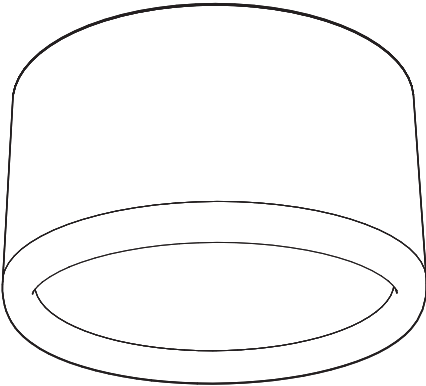

BuzziJet Ceiling Mounted

1 PERS. 

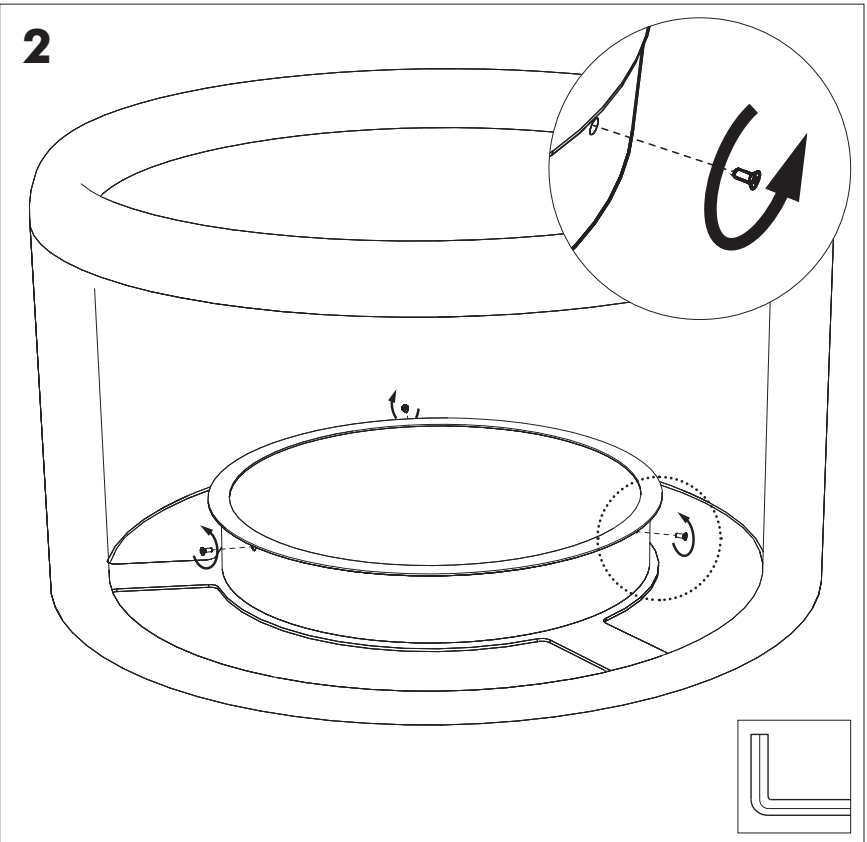
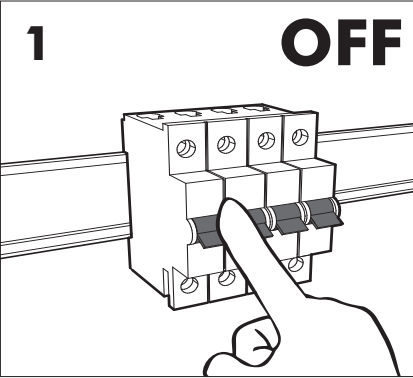
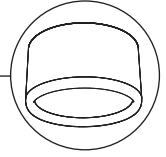

3

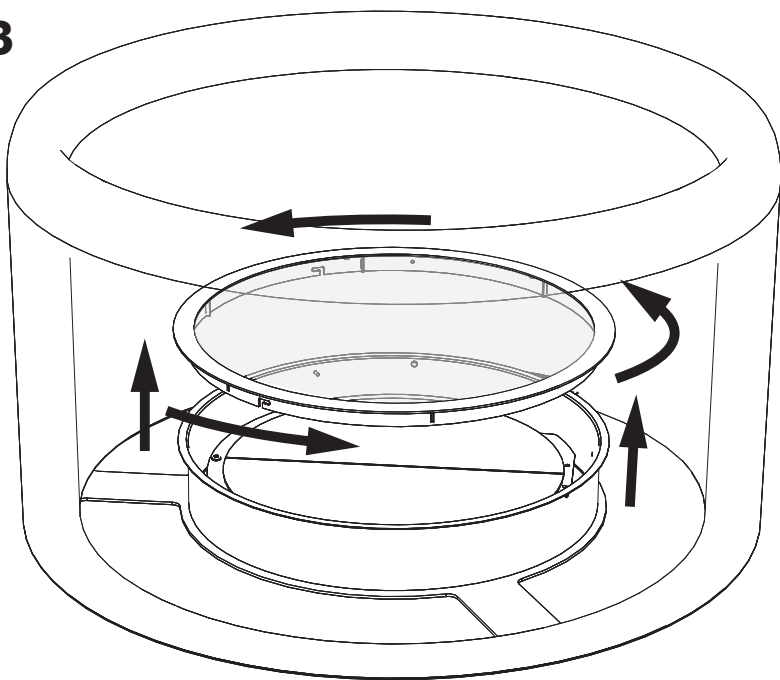

4

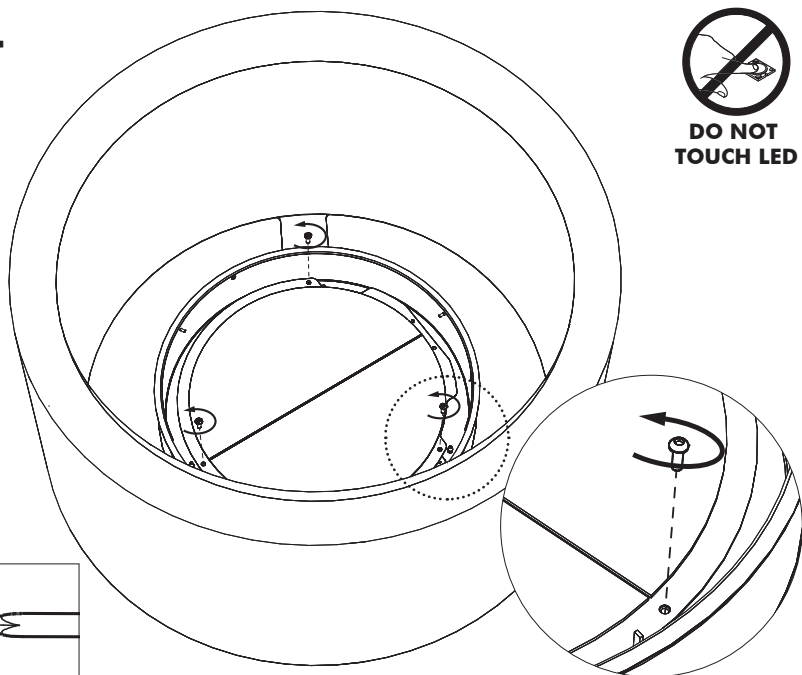

5

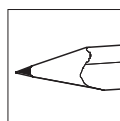
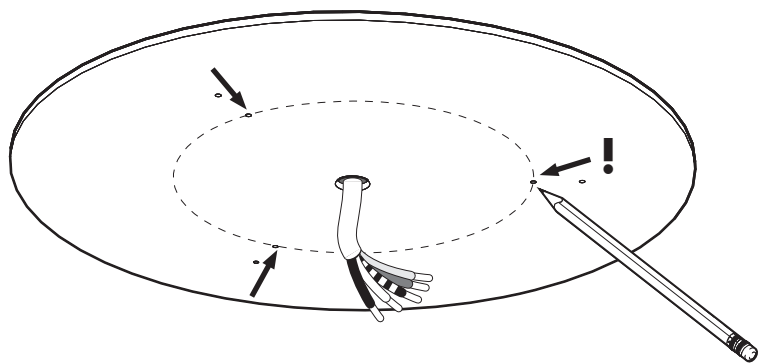

6

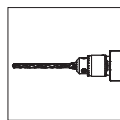
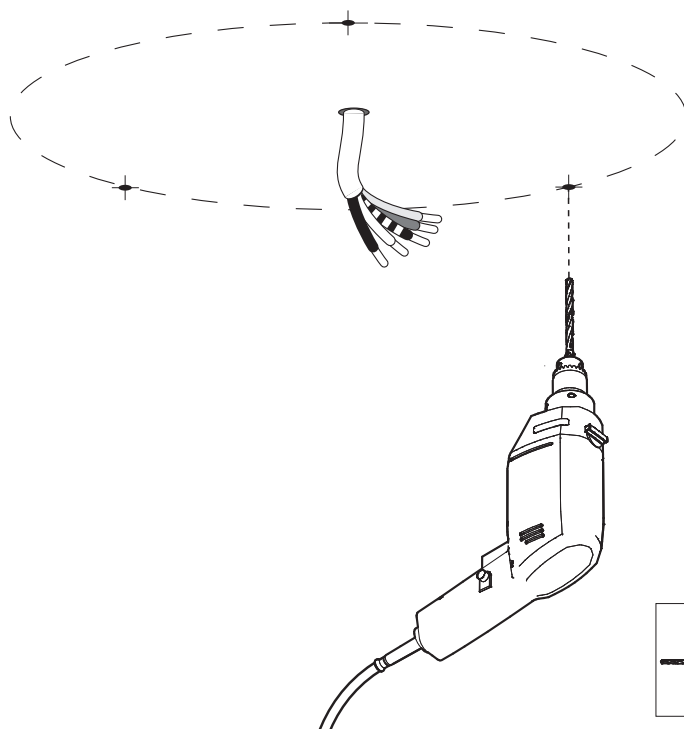

7a

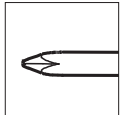
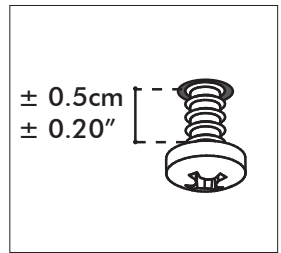
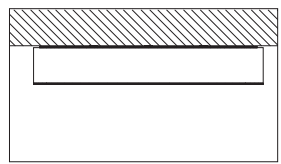
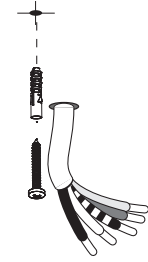

7b

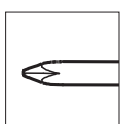
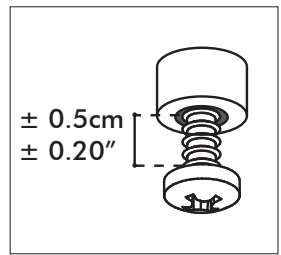
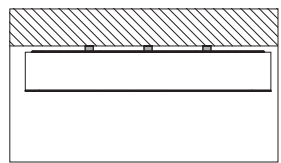
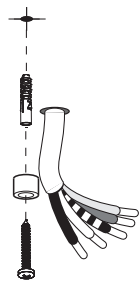

8a

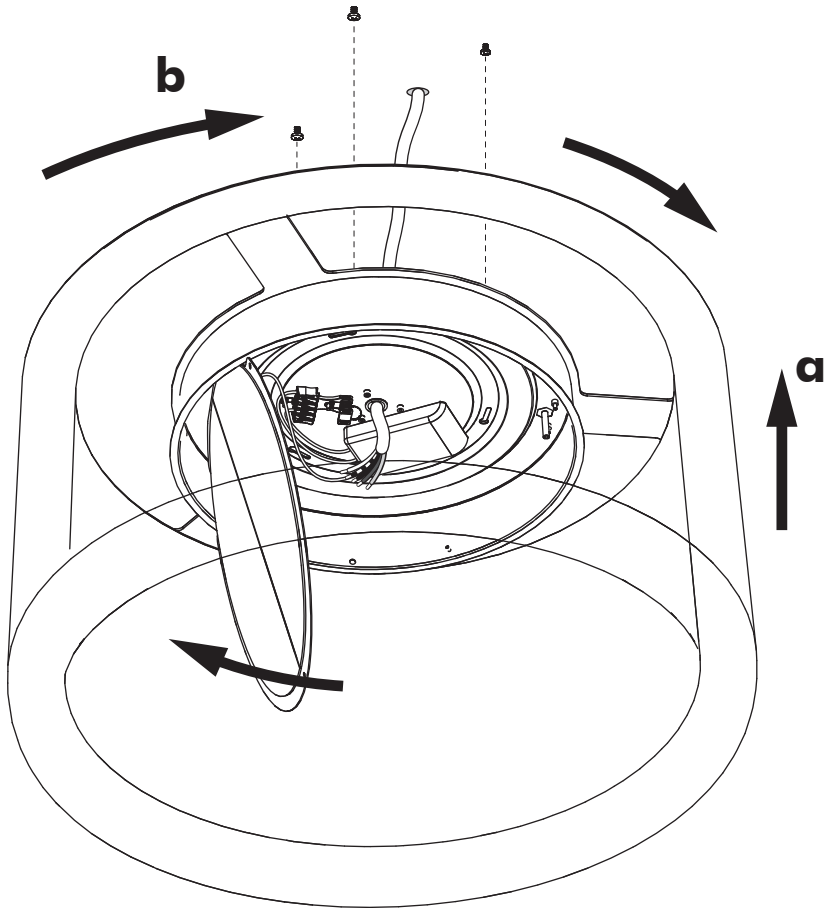
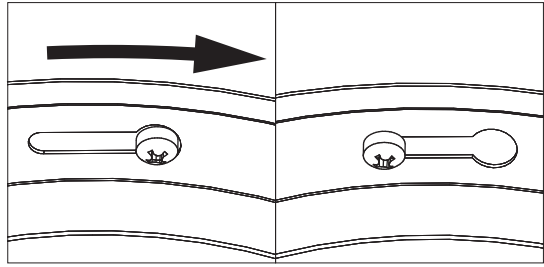

8b

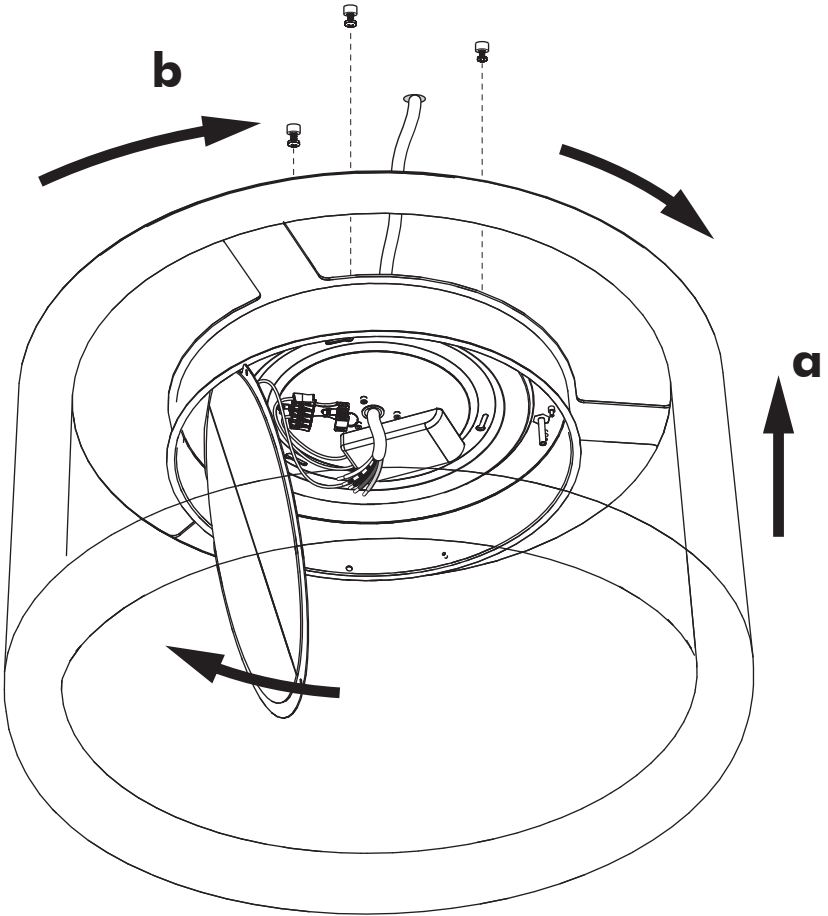
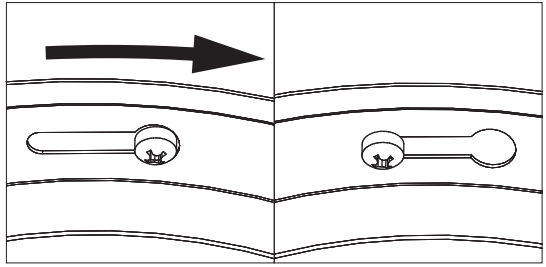

9

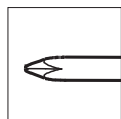
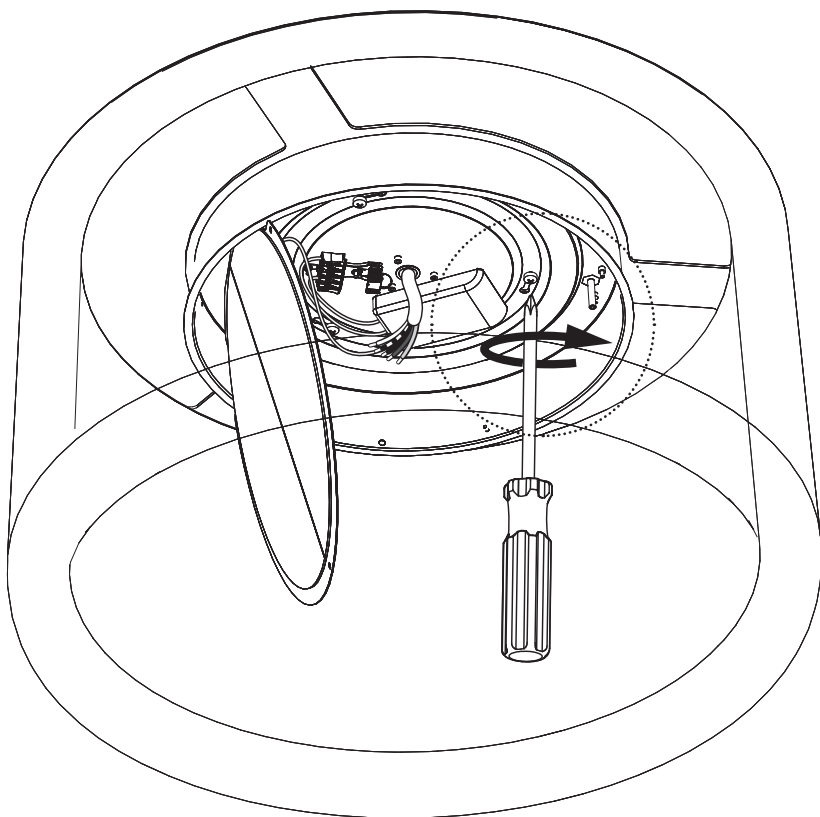
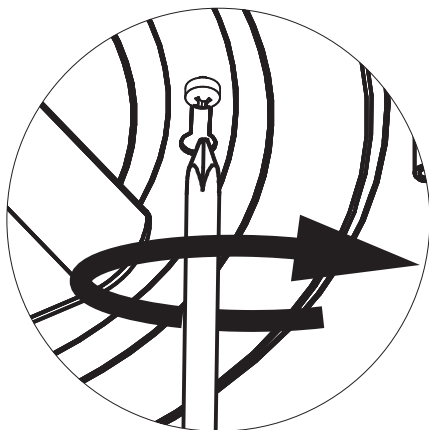

10a

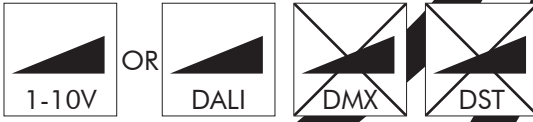

Connection including dimmable function

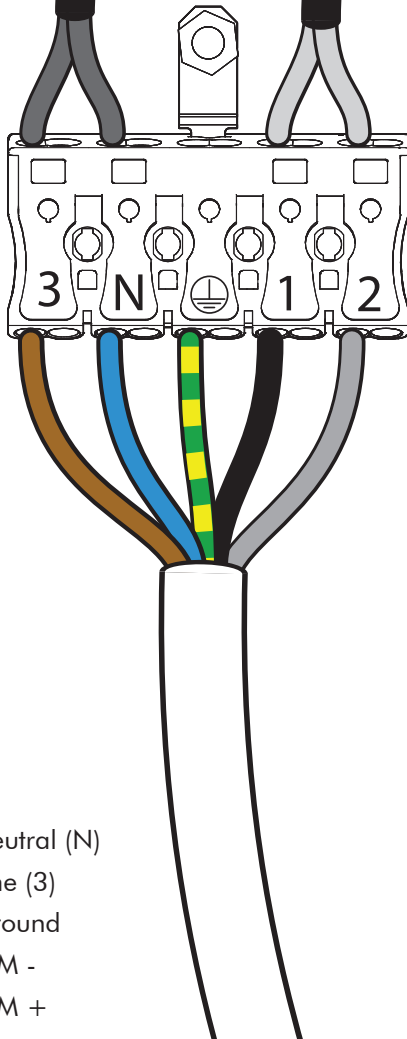

- Blue Neutral (N)
- Brown Line (3)
- Green Ground
- Black DIM -
- Grey DIM +

10b Connection excluding dimmable function

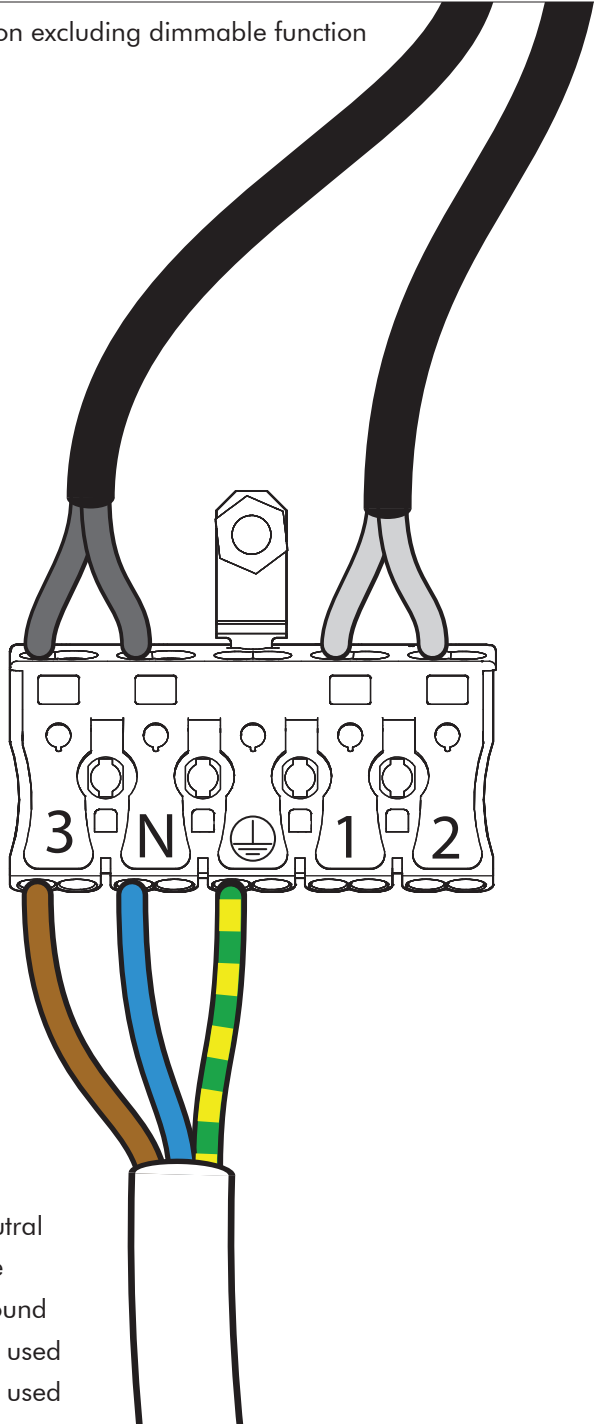

Blue	Neutral
Brown	Line
Green	Ground
1	Not used
2	Not used

11

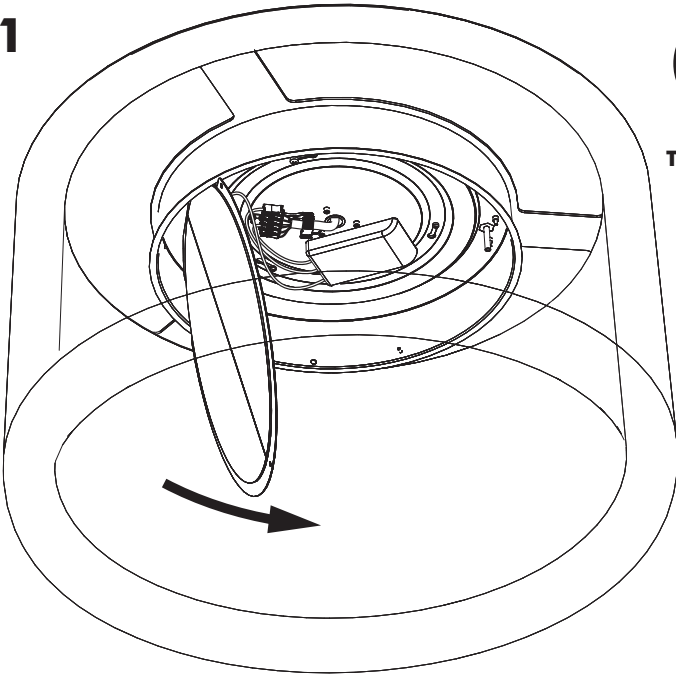

DO NOT
TOUCH LED

12

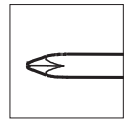
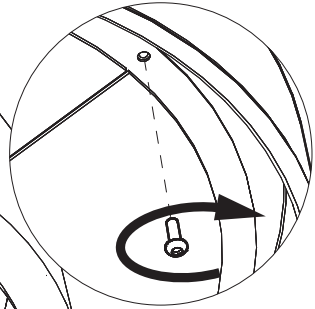
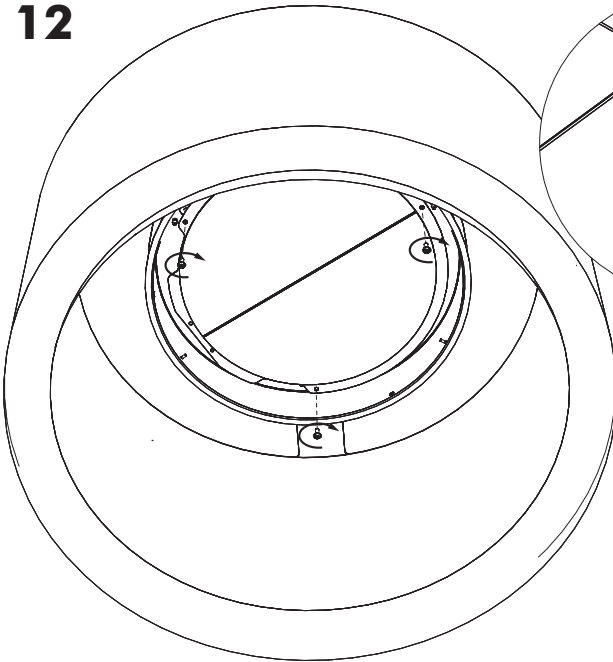

13

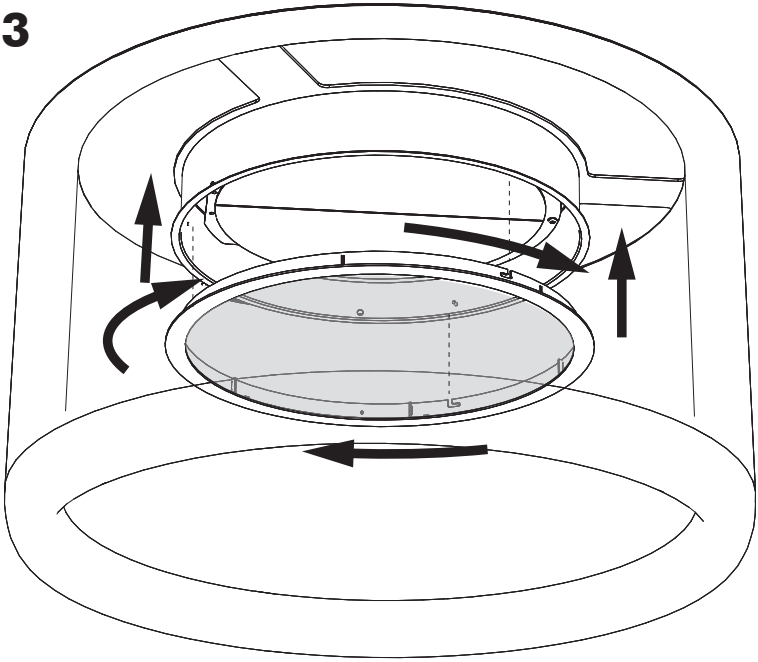

14

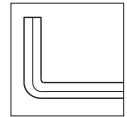
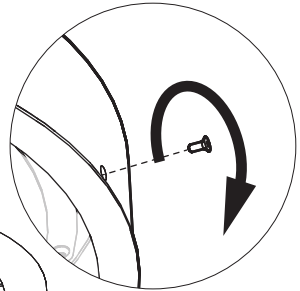
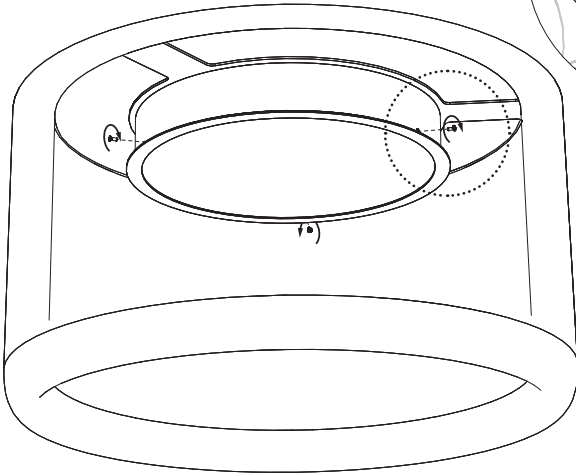

15

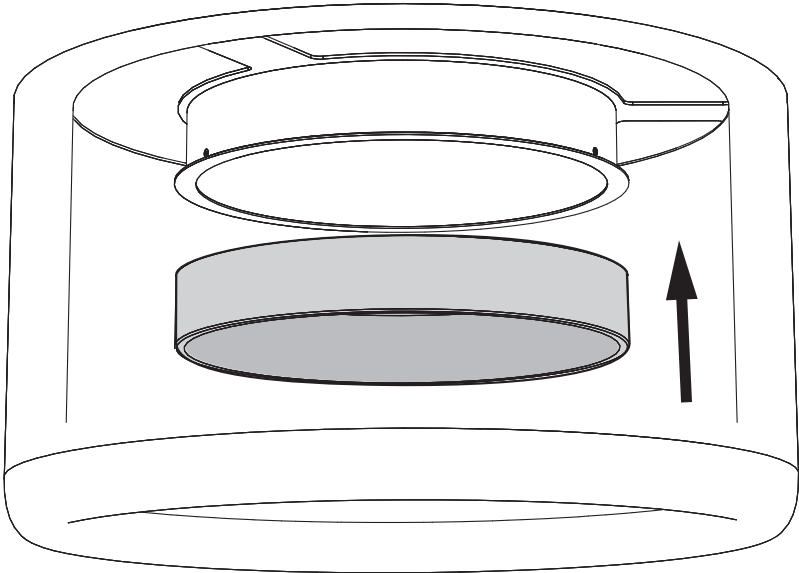

BuzziSpace Group NV
Italiëlei 8, 2000 Antwerp
Belgium

☎ +32 (0)3 846 10 00

✉ info@buzzi.space

🌐 www.buzzi.space



A-000007548/01

Last update: 01/12/2023