

BuzziJet Ceiling Suspended XL

INSTALLATION MANUAL
220-240V

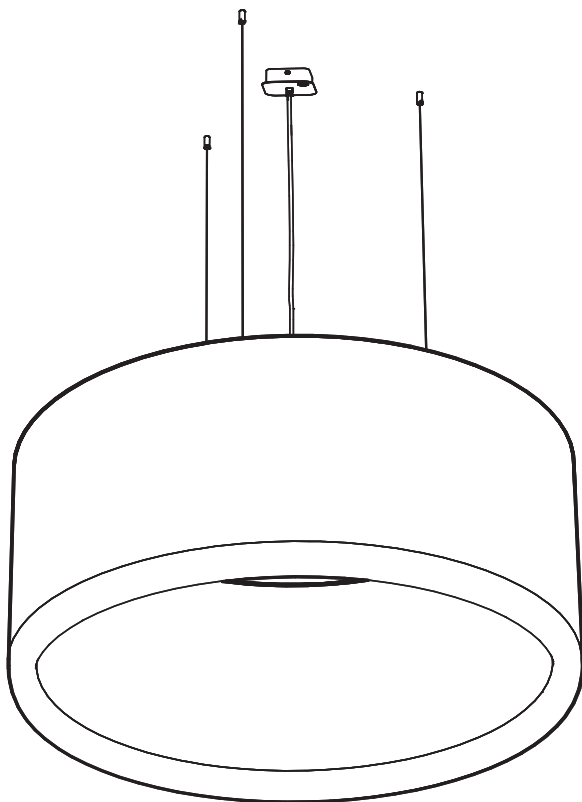

Technical info

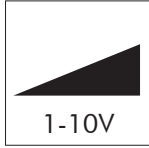
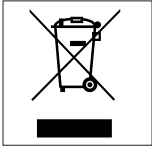
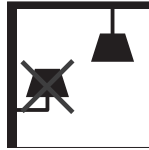
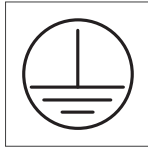
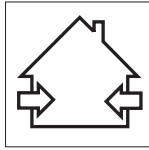

OR



Environmental Protection

Waste electrical products should not be disposed of with household waste. Please recycle where facilities exist. Check with your Local Authority or retailer for recycling advice.

⚠ The light source of this luminaire is not replaceable; when the light source reaches its end of life the whole luminaire shall be replaced.

Excluded

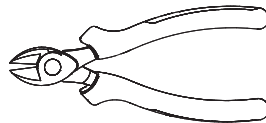
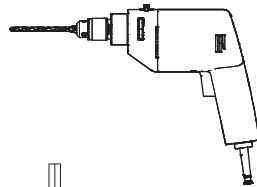
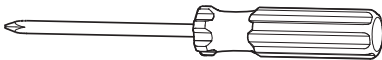
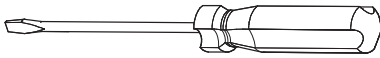

Included BuzziJet Suspended XL

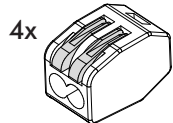
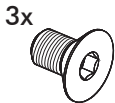
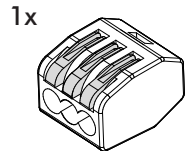
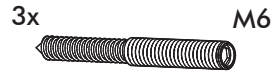
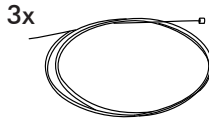
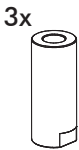
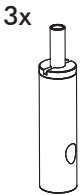
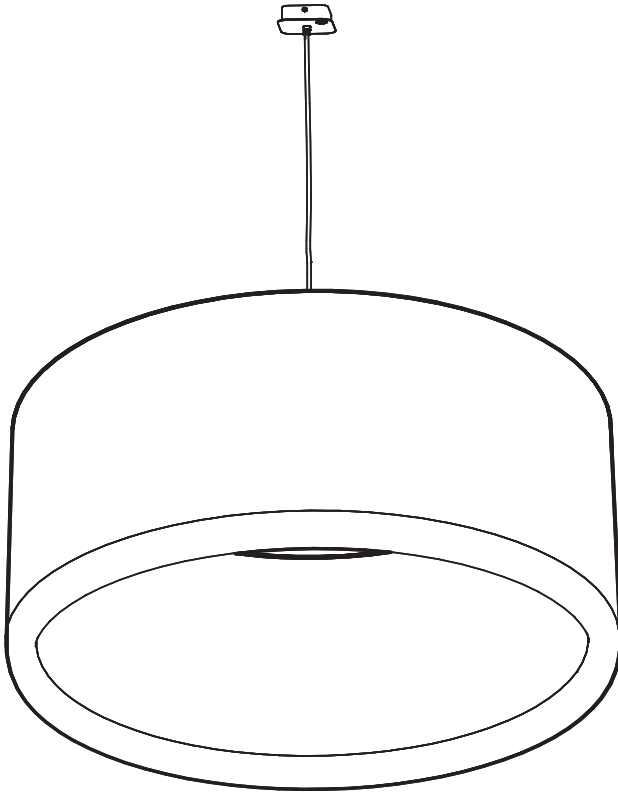

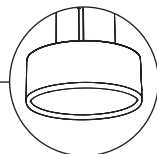

2 PERS. 

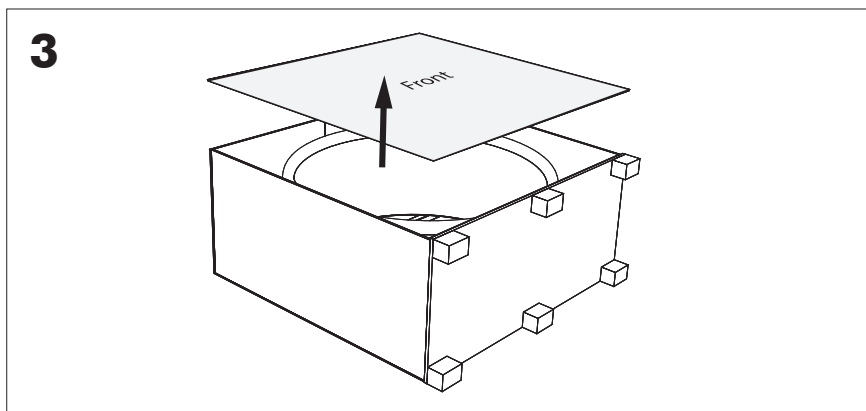
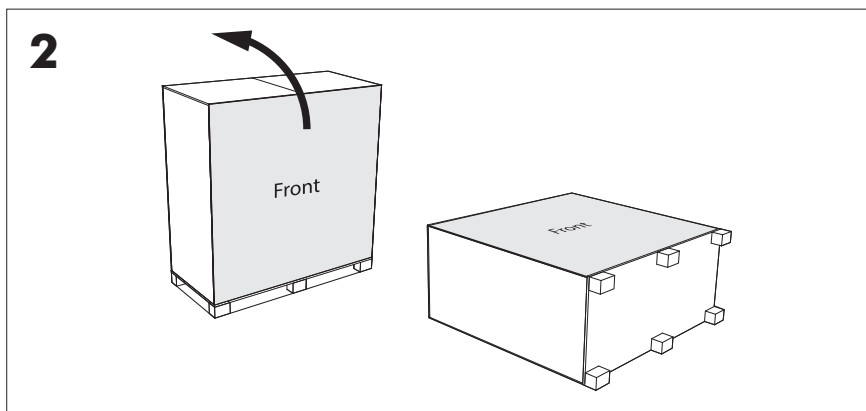
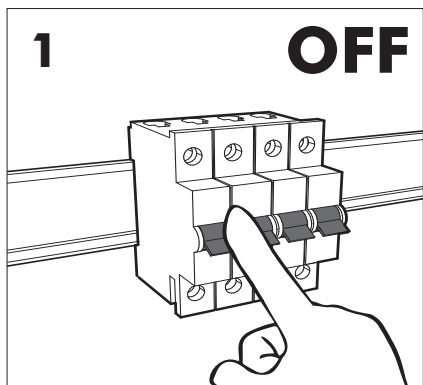

4

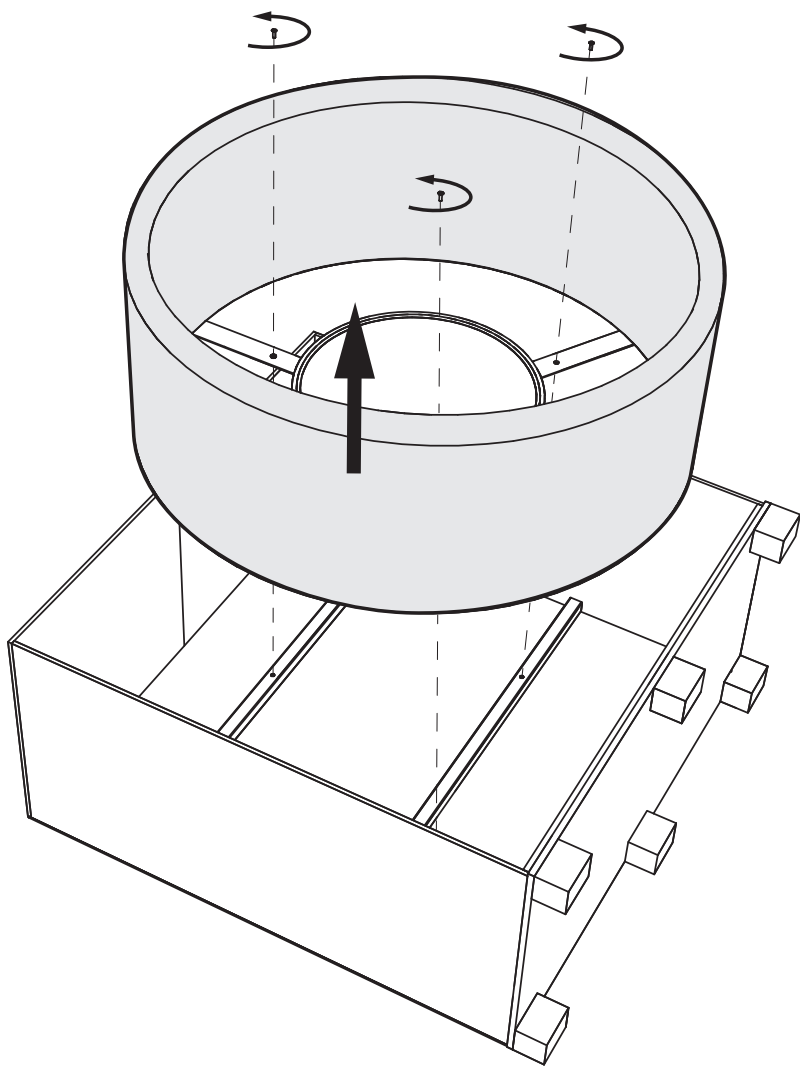

5

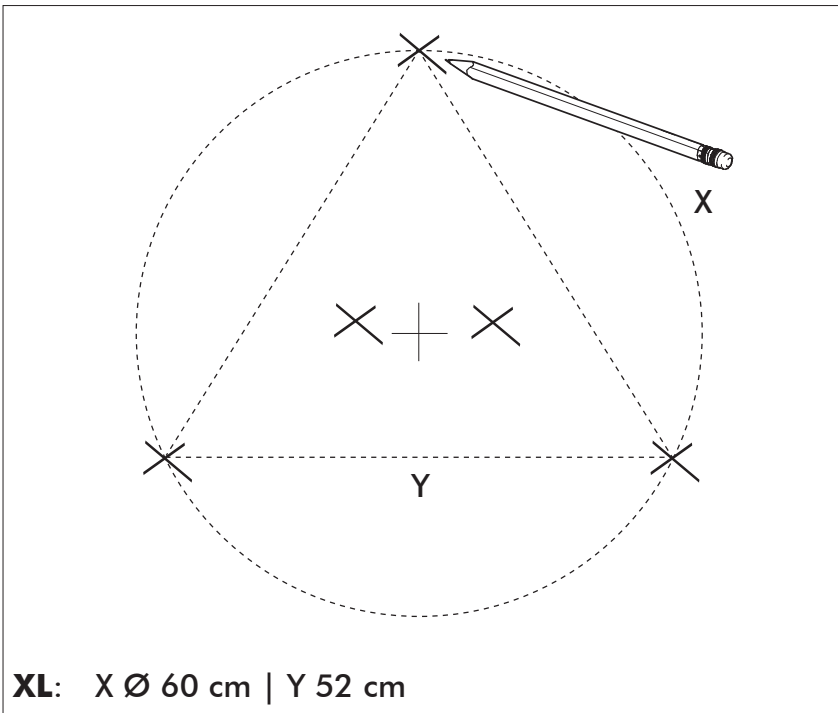

XL: X Ø 60 cm | Y 52 cm

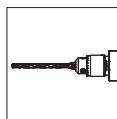
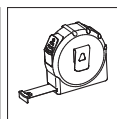
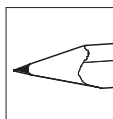
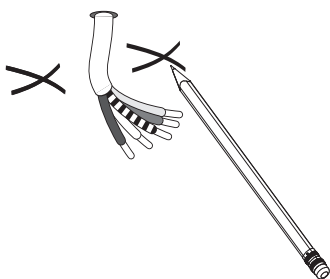

6

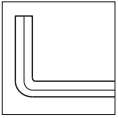
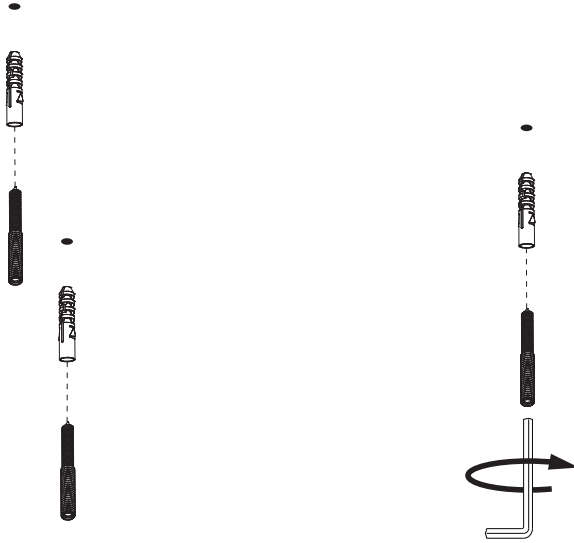

7

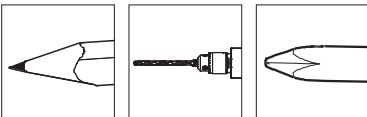
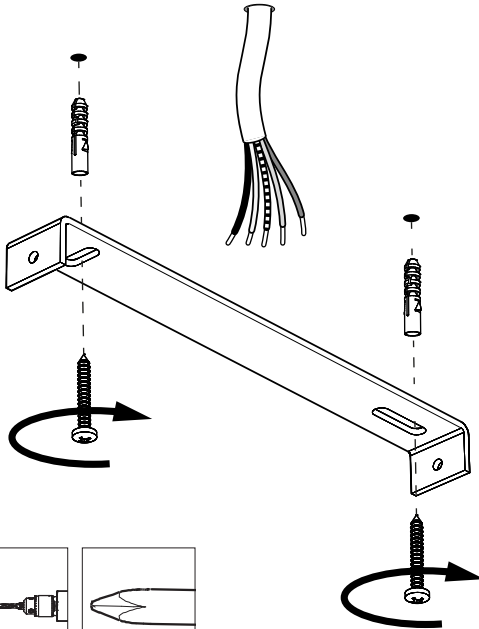

8

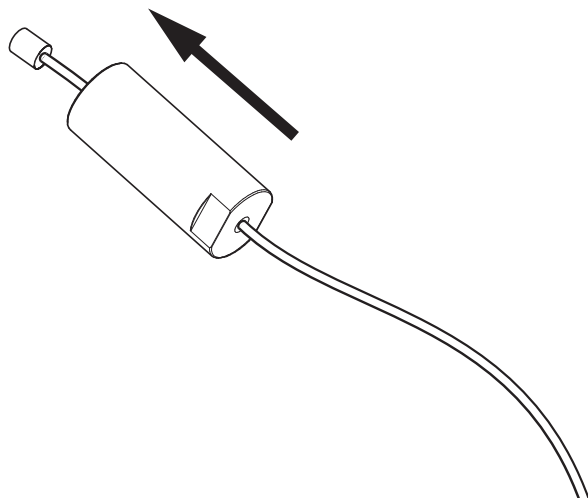
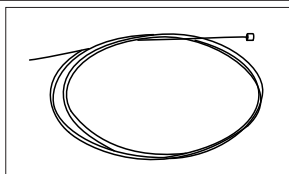

9

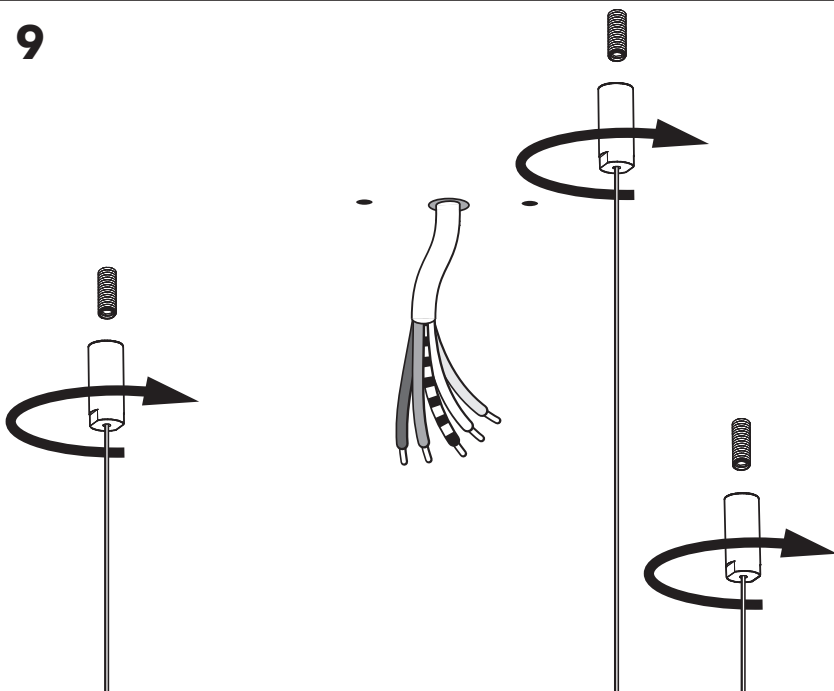

10

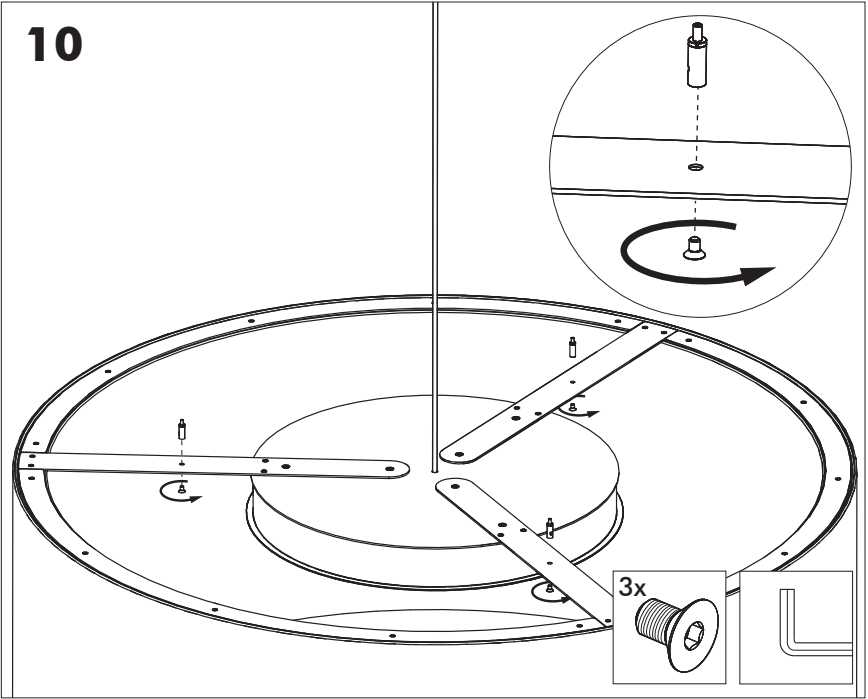

11

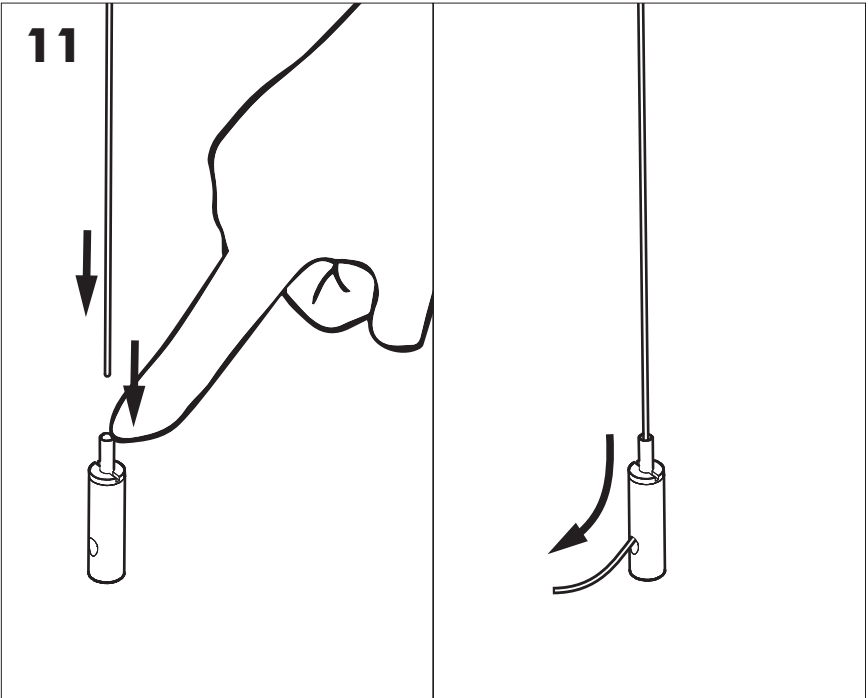

12a



1-10V



DALI



DMX



DST

Connection including dimmable function



1-10V

Dim-

Dim+

Blue	Neutral
Brown	Line
Green/Yellow	Ground
White	DIM -
Black	DIM +

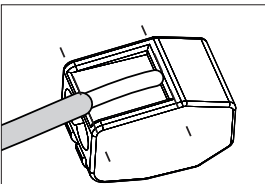

Strip conductor
to $\pm 10 \text{ mm}$ | $\pm 0.4''$

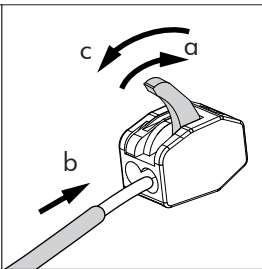

12b Connection excluding dimmable function

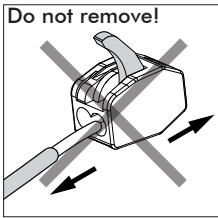
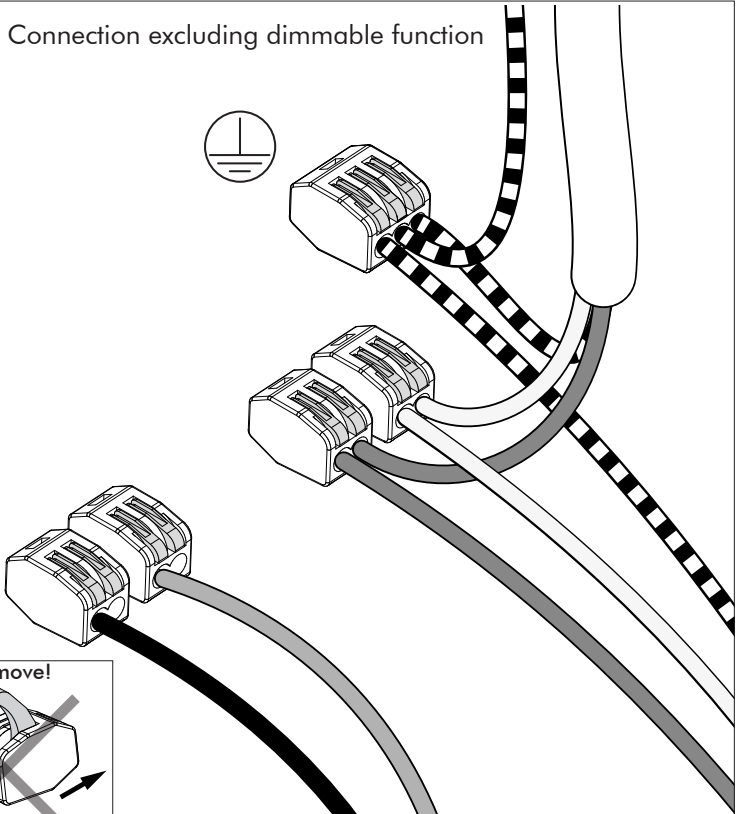

Blue	Neutral
Brown	Line
Green/Yellow	Ground
White	Not used
Black	Not used

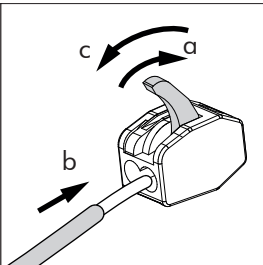
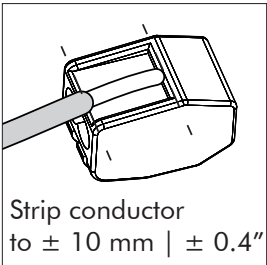

13

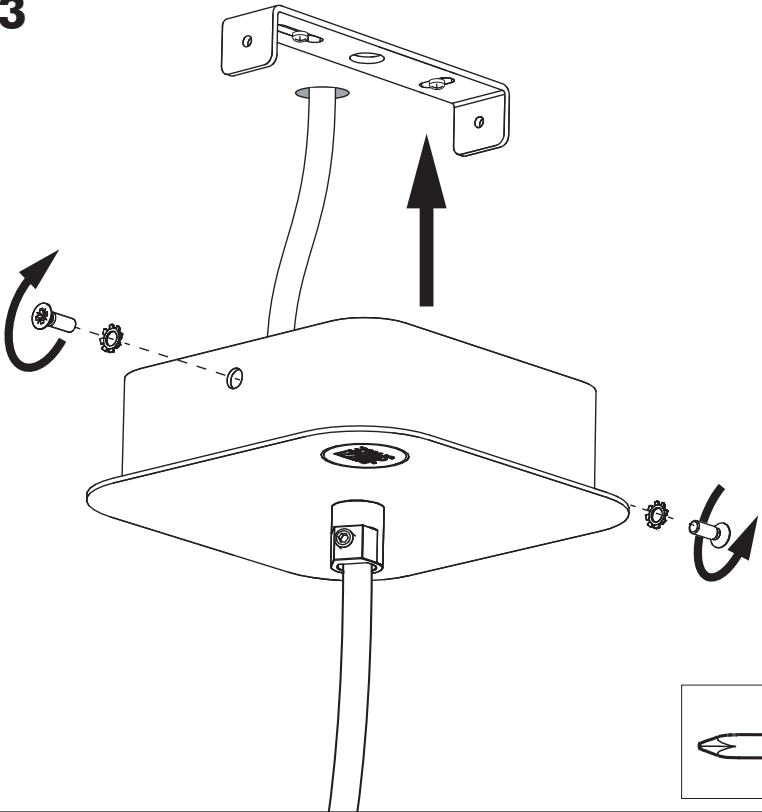

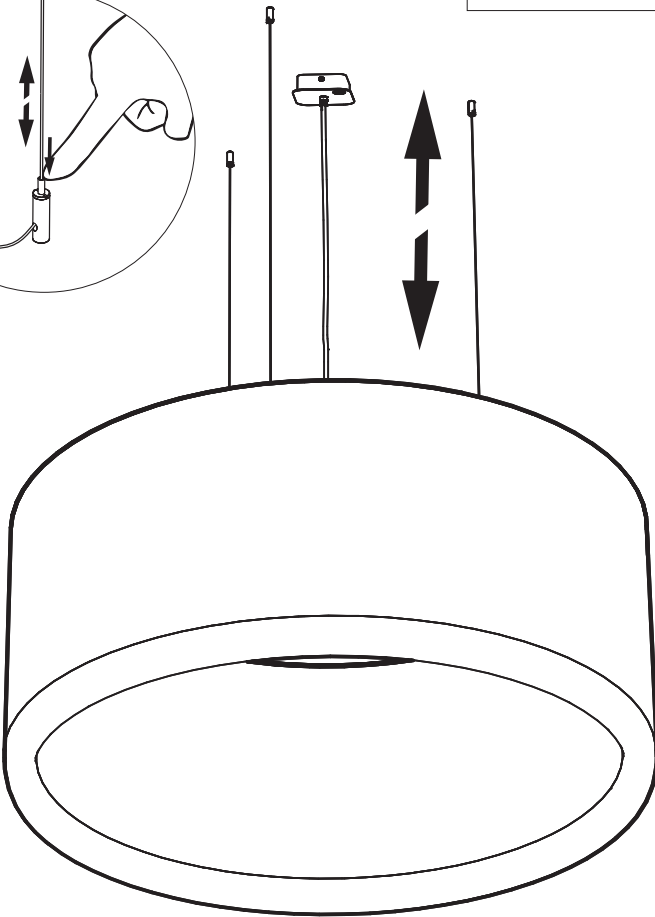
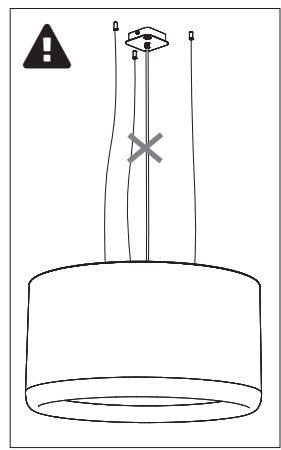
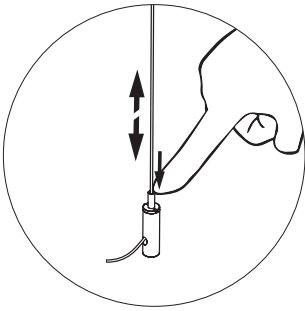
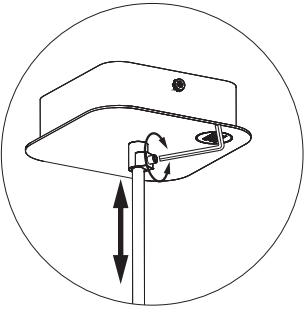

BuzziSpace Group NV
Italiëlei 8, 2000 Antwerp
Belgium

☎ +32 (0)3 846 10 00

✉ info@buzzi.space

🌐 www.buzzi.space

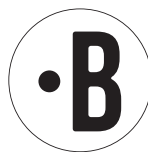

A-0000007796/01
Last update: 01/12/2023