

BuzziJet Ceiling Suspended XL

INSTALLATION MANUAL
230V

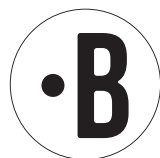

Technical info

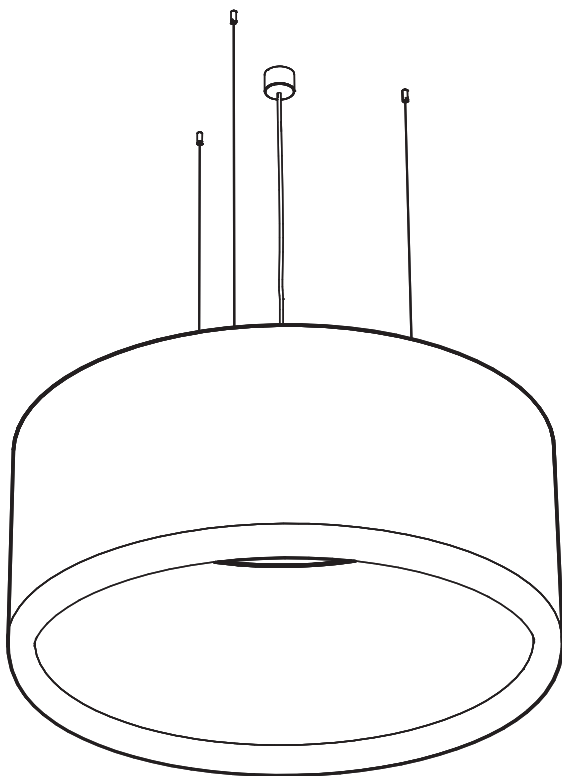
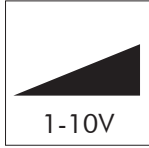
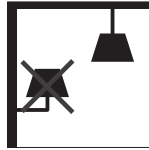
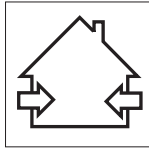

OR



Environmental Protection

Waste electrical products should not be disposed of with household waste. Please recycle where facilities exist. Check with your Local Authority or retailer for recycling advice.

⚠ The light source of this luminaire is not replaceable; when the light source reaches its end of life the whole luminaire shall be replaced.

Excluded

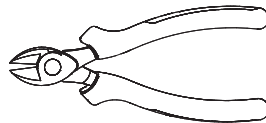
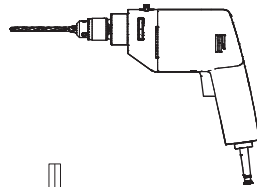
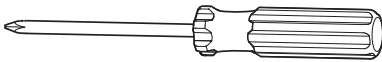
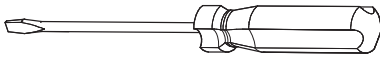

Included BuzziJet Ceiling Suspended XL

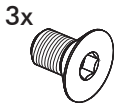
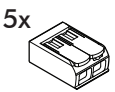
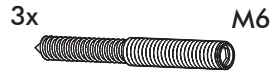
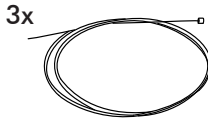
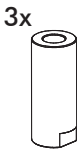
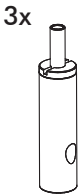
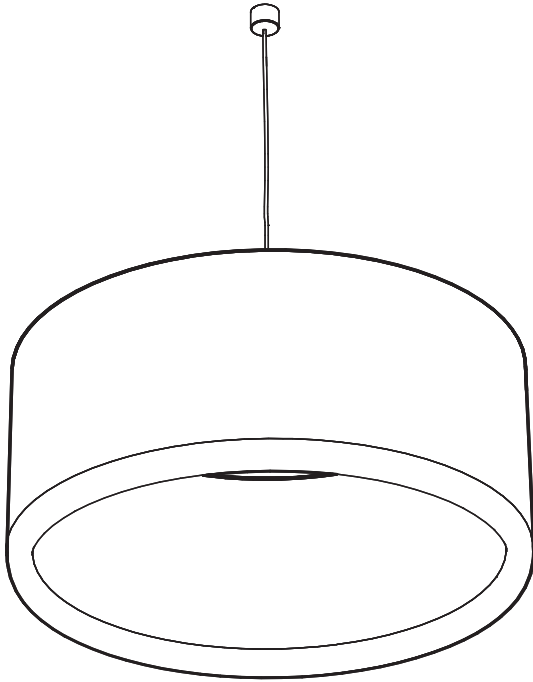

BuzziJet Ceiling Suspended XL

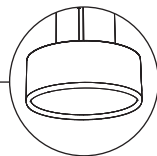

2 PERS. 

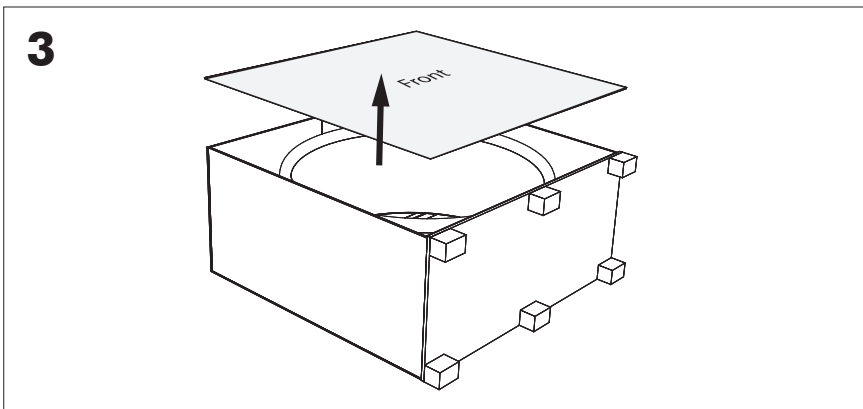
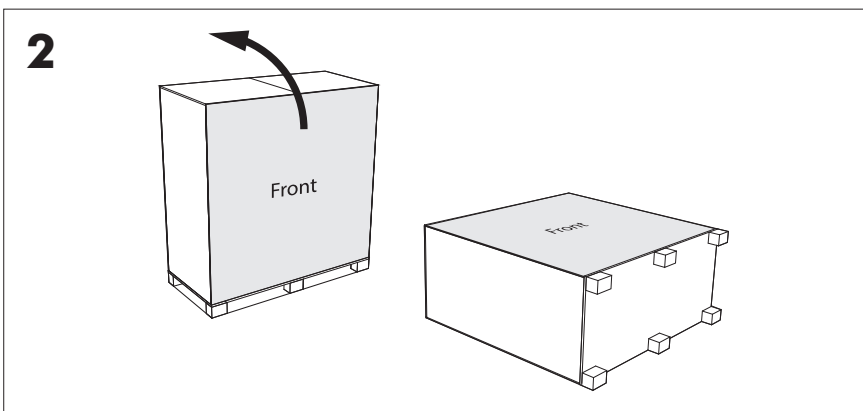
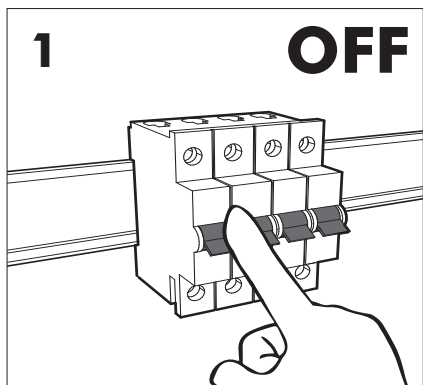

4

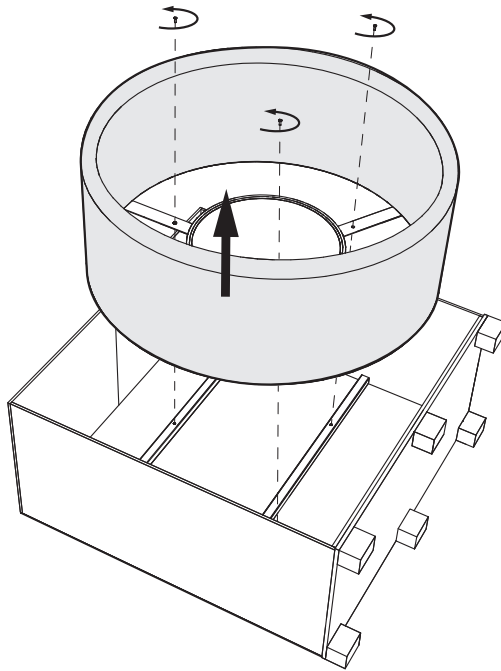

5

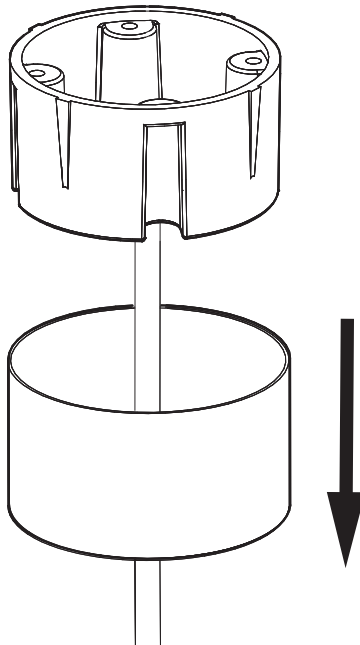

6

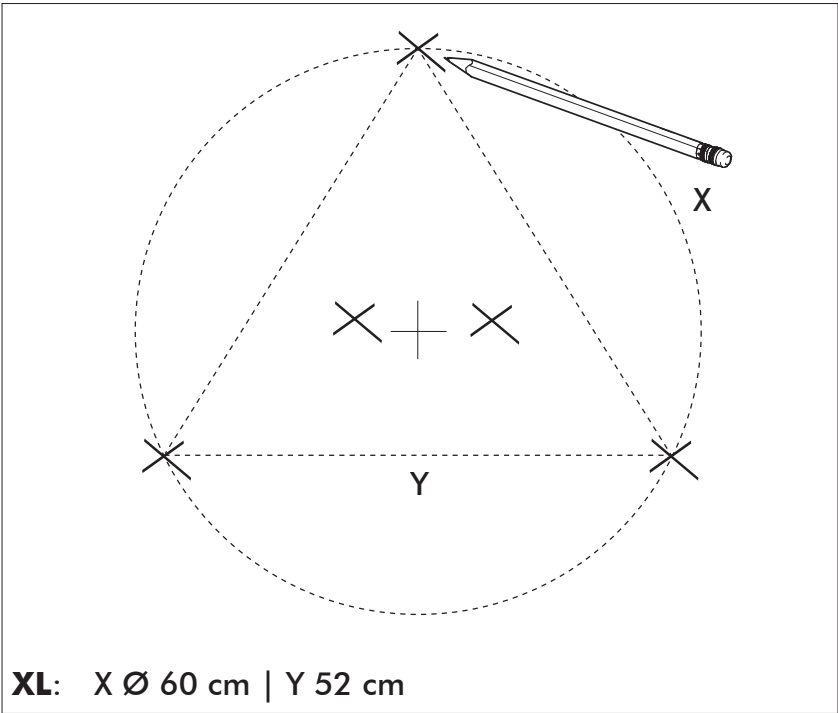

XL: X Ø 60 cm | Y 52 cm

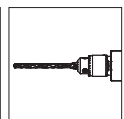
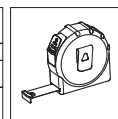
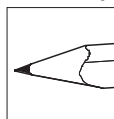
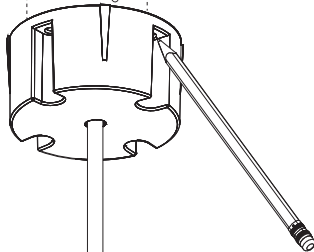
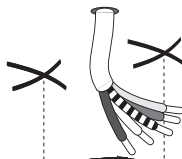

7

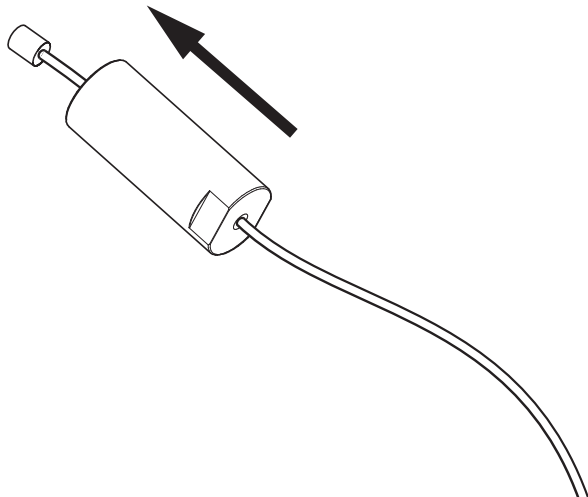
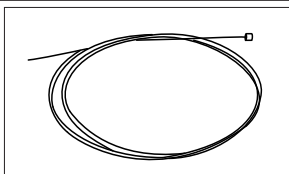

8

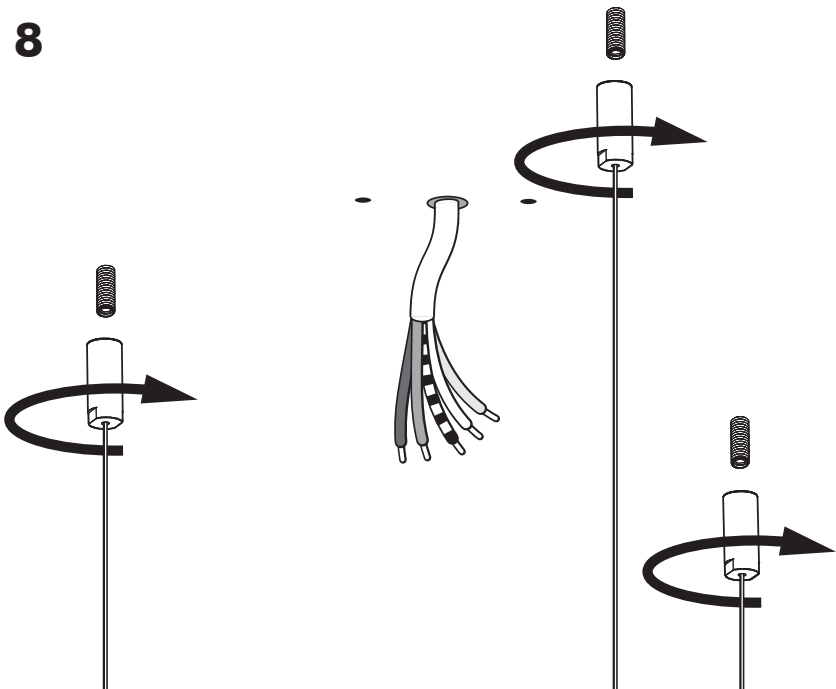

9

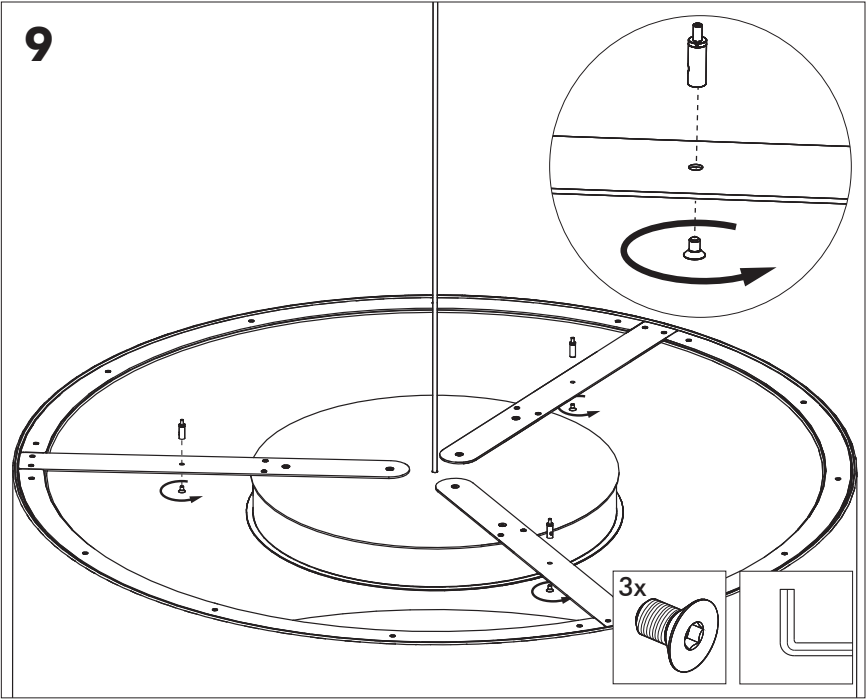

10

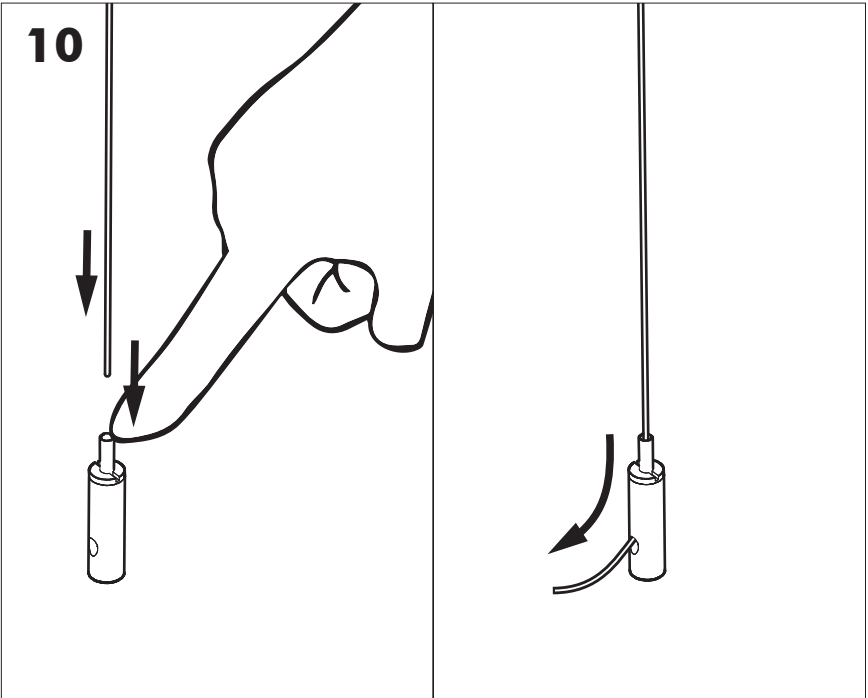

11a

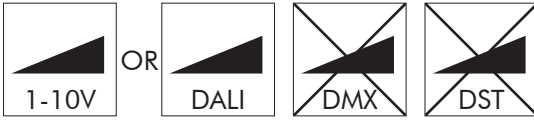

Connection including dimmable function

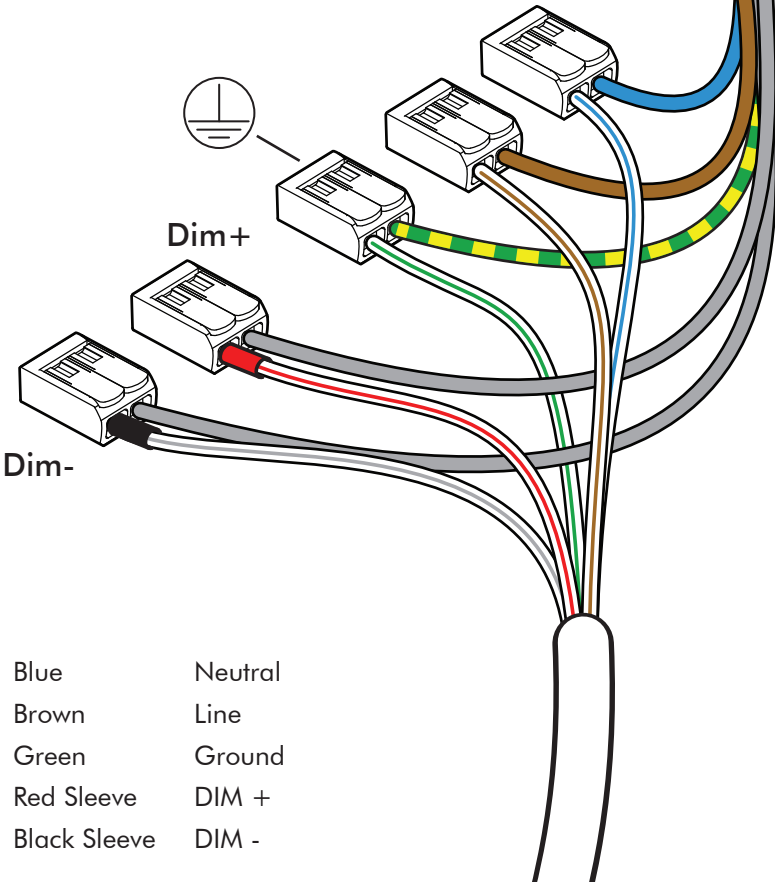

11b

Connection excluding dimmable function

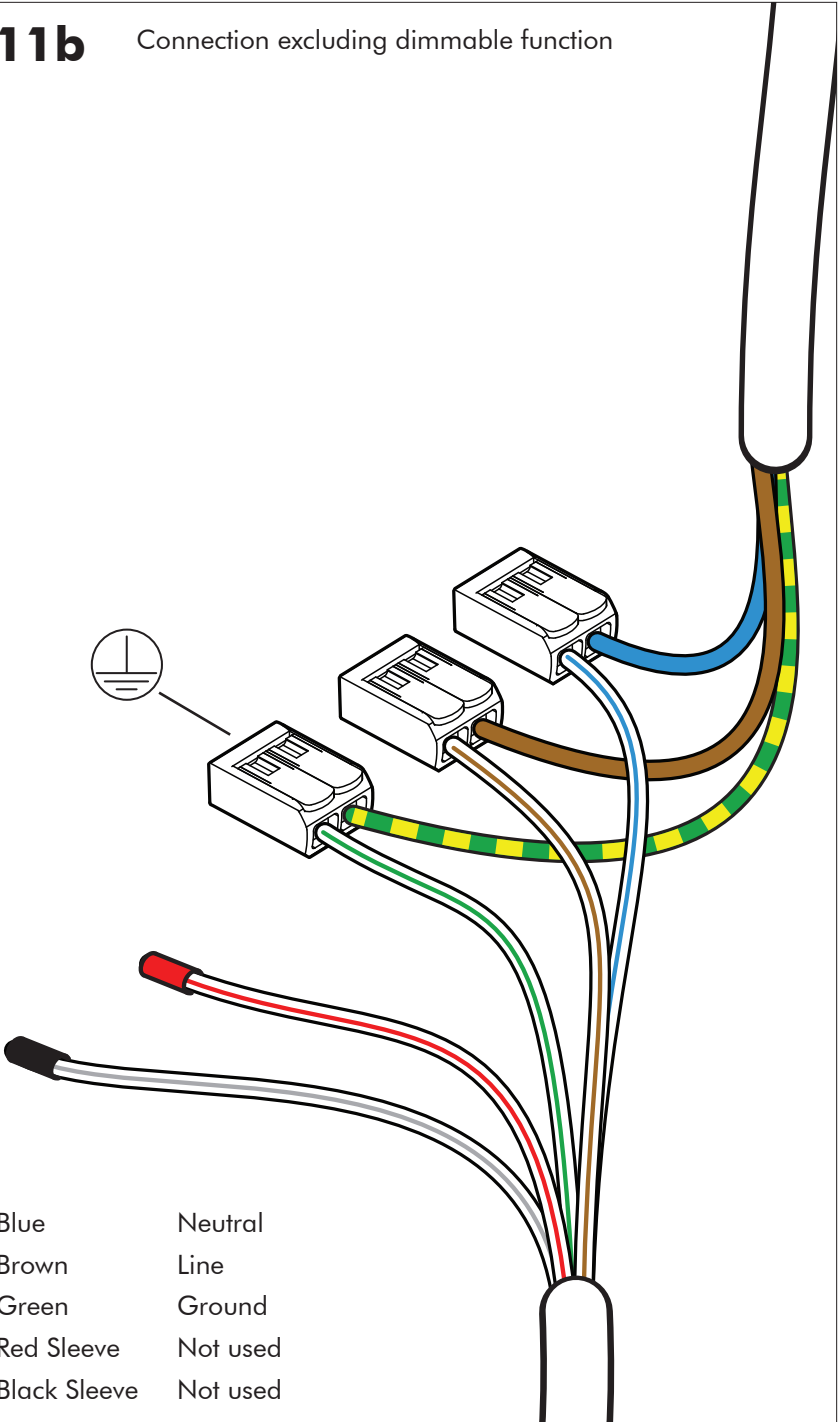

12

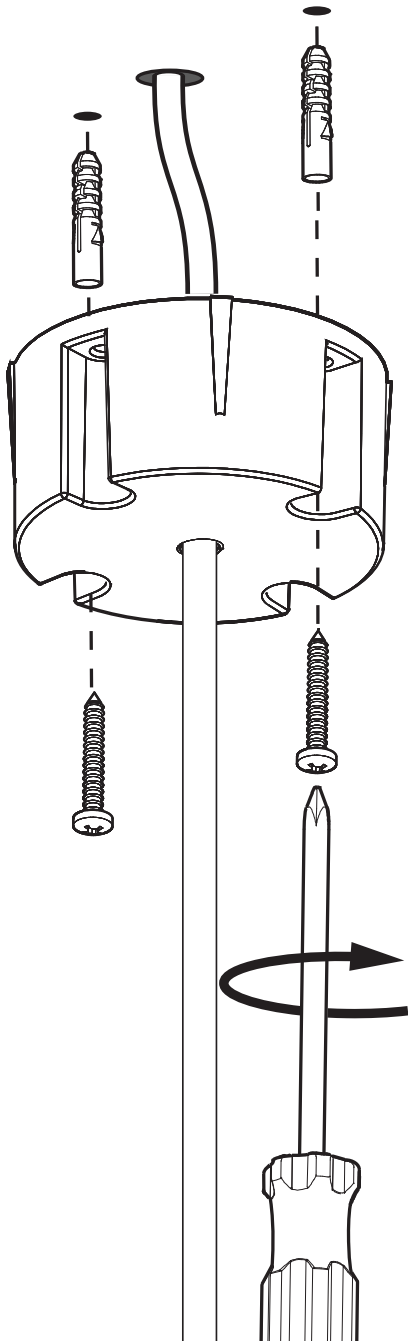

13

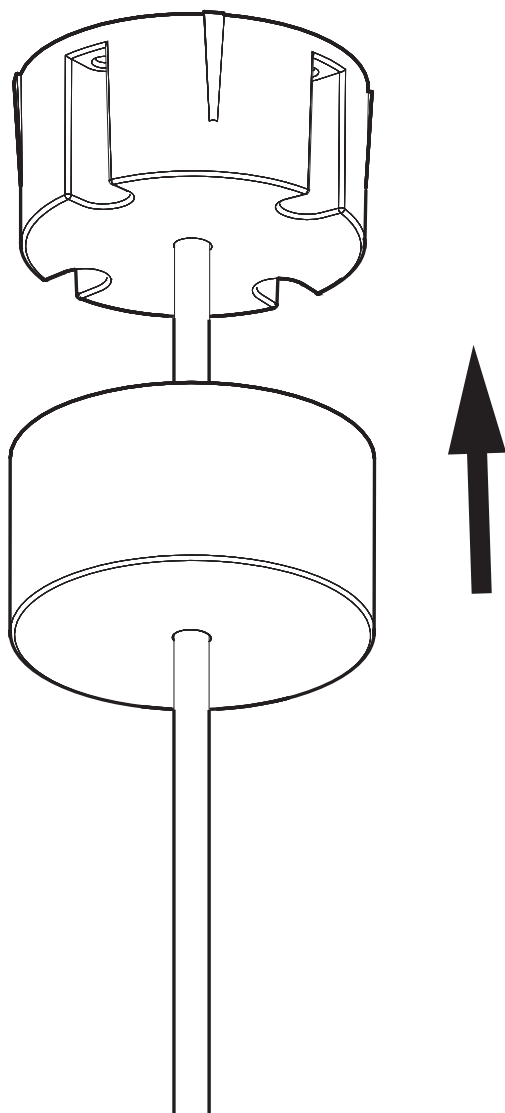

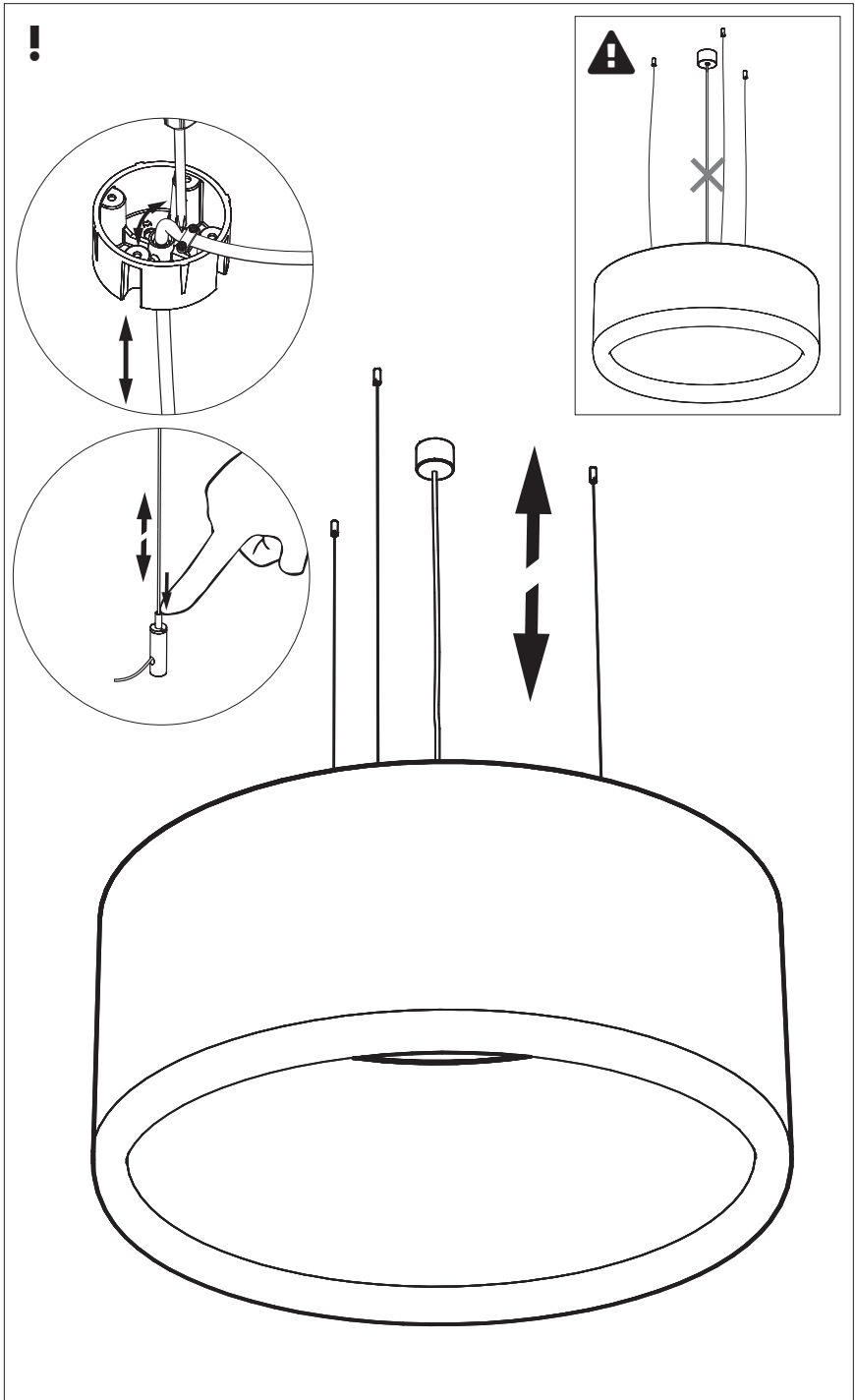

BuzziSpace Group NV
Italiëlei 8, 2000 Antwerp
Belgium

☎ +32 (0)3 846 10 00

✉ info@buzzi.space

🌐 www.buzzi.space



A-0000007798/01
Last update: 01/12/2023