

# BuzziSpark

Electrification Unit 220 - 240V

INSTALLATION MANUAL

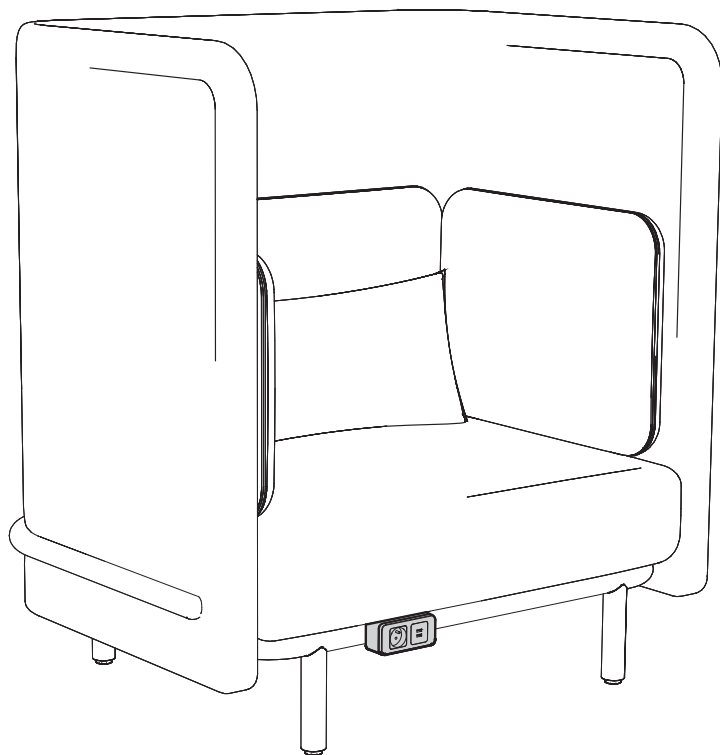

## Technical info

---

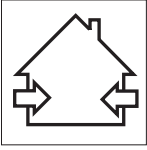

## Environmental Protection

Waste electrical products should not be disposed of with household waste. Please recycle where facilities exist. Check with your Local Authority or retailer for recycling advice.

### France / Belgium

---

Article reference: P0179-ELEC.01  
1 x Socket outlet: 250Vac / 16A  
Type E (BE/FR/PO/SL)  
Max 3500W  
Pen earthing  
Child safety mechanism included  
2 x USB outlet: USB-connector Type A  
Max. combined output 2.1A, 5V DC (10.5VA)  
Cable: Length 3 m - black  
Cable type 3G1,5 mm<sup>2</sup>  
Plug type – angled Type E & F hybrid CEE 7/7  
Certification: CE  
Color: Black  
Dimensions front: 137 x 63 mm

### Germany / Netherlands

---

Article reference: P0179-ELEC.02  
1 x Socket outlet: 250Vac / 16A  
Type F (Schuko - DE/NL/SP/NO/SW)  
Max 3500W  
Side earthing  
Child safety mechanism included  
2 x USB outlet: USB-connector Type A  
Max. combined output 2.1A, 5V DC (10.5VA)  
Cable: Length 3 m - black  
Cable type 3G1,5 mm<sup>2</sup>  
Plug type – angled Type E & F hybrid CEE 7/7  
Certification: CE  
Color: Black  
Dimensions front: 137 x 63 mm

## UK

---

Article reference: P0179-ELEC.03  
1 x Socket outlet: 250Vac / 13A  
Type G (UK/IR/MA)  
GB-Y fused 3,15A  
Child safety mechanism included  
2 x USB outlet: USB-connector Type A  
Max. combined output 2.1A, 5V DC (10.5VA)  
Cable: Length 3 m - black  
Cable type 3G1,5 mm<sup>2</sup>  
Plug type G – 13A  
Certification: CE  
Color: Black  
Dimensions front: 137 x 63 mm

# BuzziSpark Tablet

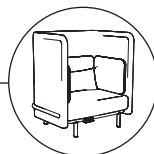

1 PERS. 

## Included

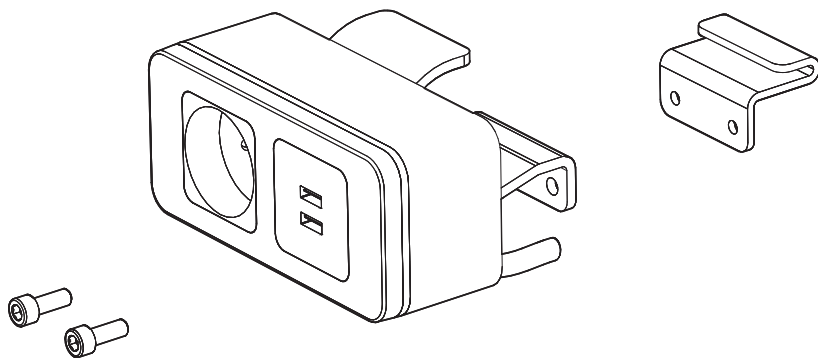

1

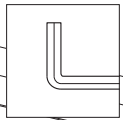
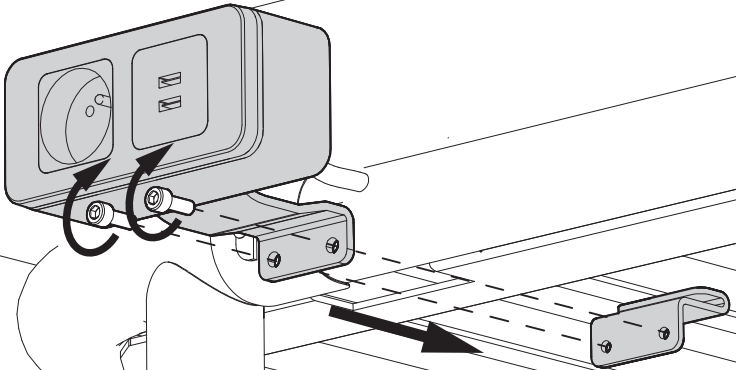
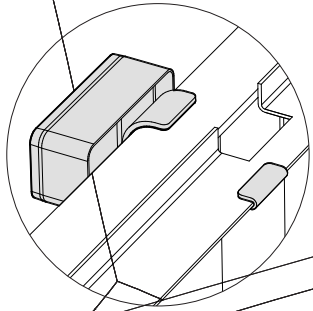

**2**

**France / Belgium**

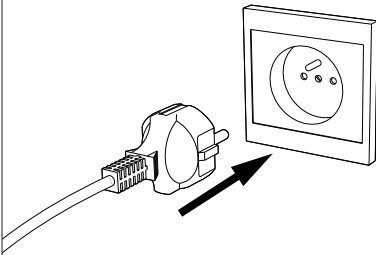

**Germany / Netherlands**

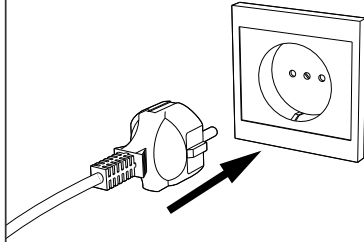

**UK**

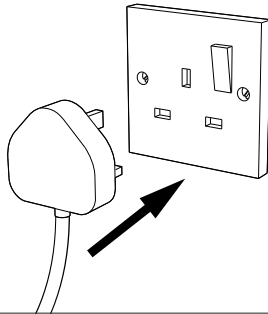



**BuzziSpace Group NV**  
Italiëlei 8, 2000 Antwerp  
Belgium

☎ +32 (0)3 846 10 00

✉ [info@buzzi.space](mailto:info@buzzi.space)

🌐 [www.buzzi.space](http://www.buzzi.space)

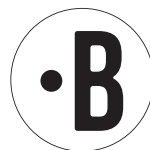

Doc nr.: A-0000006456/01

Last update: 08/12/2023